

AERONAUTICAL STRUCTURE & EQUIPMENT FITTER

NSQF LEVEL - 4

1st Year

TRADE PRACTICAL

SECTOR: CAPITAL GOODS & MANUFACTURING

(As per revised syllabus July 2022 - 1200 Hrs)



Directorate General of Training

DIRECTORATE GENERAL OF TRAINING
MINISTRY OF SKILL DEVELOPMENT & ENTREPRENEURSHIP
GOVERNMENT OF INDIA



**NATIONAL INSTRUCTIONAL
MEDIA INSTITUTE, CHENNAI**

Post Box No. 3142, CTI Campus, Guindy, Chennai - 600 032

Sector : Capital Goods & Manufacturing

Duration : 2 Years

**Trades : Aeronautical Structure & Equipment Fitter - 1st Year
Trade Practical - NSQF LEVEL - 4**

Developed & Published by



National Instructional Media Institute

Post Box No.3142

Guindy, Chennai - 600 032

INDIA

Email: chennai-nimi@nic.in

Website: www.nimi.gov.in

First Edition : November 2022

Copies : 500

FOREWORD

The Government of India has set an ambitious target of imparting skills to 30 crores people, one out of every four Indians, by 2020 to help them secure jobs as part of the National Skills Development Policy. Industrial Training Institutes (ITIs) play a vital role in this process especially in terms of providing skilled manpower. Keeping this in mind, and for providing the current industry relevant skill training to Trainees, ITI syllabus has been recently updated with the help of Media Development Committee members of various stakeholders viz. Industries, Entrepreneurs, Academicians and representatives from ITIs.

The National Instructional Media Institute (NIMI), Chennai, has now come up with instructional material to suit the revised curriculum for **Aeronautical Structure & Equipment Fitter, 1st Year Trade Practical NSQF Level - 4 in Capital Goods & Manufacturing Sector under Yearly Pattern**. The NSQF Level - 4 Trade Practical will help the trainees to get an international equivalency standard where their skill proficiency and competency will be duly recognized across the globe and this will also increase the scope of recognition of prior learning. NSQF Level - 4 trainees will also get the opportunities to promote life long learning and skill development. I have no doubt that with NSQF Level - 4 the trainers and trainees of ITIs, and all stakeholders will derive maximum benefits from these Instructional Media Packages IMPs and that NIMI's effort will go a long way in improving the quality of Vocational training in the country.

The Executive Director & Staff of NIMI and members of Media Development Committee deserve appreciation for their contribution in bringing out this publication.

Jai Hind

Ms. TRISHALJIT SETHI

Addl. Secretary / Directorate General of Training
Ministry of Skill Development & Entrepreneurship
Government of India.

New Delhi - 110 001

PREFACE

The National Instructional Media Institute (NIMI) was established in 1986 at Chennai by then Directorate General of Employment and Training (D.G.E & T), Ministry of Labour and Employment, (now under Directorate General of Training, Ministry of Skill Development and Entrepreneurship) Government of India, with technical assistance from the Govt. of Federal Republic of Germany. The prime objective of this Institute is to develop and provide instructional materials for various trades as per the prescribed syllabus under the Craftsman and Apprenticeship Training Schemes.

The instructional materials are created keeping in mind, the main objective of Vocational Training under NCVT/NAC in India, which is to help an individual to master skills to do a job. The instructional materials are generated in the form of Instructional Media Packages (IMPs). An IMP consists of Theory book, Practical book, Test and Assignment book, Instructor Guide, Audio Visual Aid (Wall charts and Transparencies) and other support materials.

The trade practical book consists of series of exercises to be completed by the trainees in the workshop. These exercises are designed to ensure that all the skills in the prescribed syllabus are covered. The trade theory book provides related theoretical knowledge required to enable the trainee to do a job. The test and assignments will enable the instructor to give assignments for the evaluation of the performance of a trainee. The wall charts and transparencies are unique, as they not only help the instructor to effectively present a topic but also help him to assess the trainee's understanding. The instructor guide enables the instructor to plan his schedule of instruction, plan the raw material requirements, day to day lessons and demonstrations.

IMPs also deals with the complex skills required to be developed for effective team work. Necessary care has also been taken to include important skill areas of allied trades as prescribed in the syllabus.

The availability of a complete Instructional Media Package in an institute helps both the trainer and management to impart effective training.

The IMPs are the outcome of collective efforts of the staff members of NIMI and the members of the Media Development Committees specially drawn from Public and Private sector industries, various training institutes under the Directorate General of Training (DGT), Government and Private ITIs.

NIMI would like to take this opportunity to convey sincere thanks to the Directors of Employment & Training of various State Governments, Training Departments of Industries both in the Public and Private sectors, Officers of DGT and DGT field institutes, proof readers, individual media developers and coordinators, but for whose active support NIMI would not have been able to bring out this materials.

Chennai - 600 032

EXECUTIVE DIRECTOR

ACKNOWLEDGEMENT

National Instructional Media Institute (NIMI) sincerely acknowledges with thanks for the co-operation and contribution extended by the following Media Developers and their sponsoring organisation to bring out this IMP (**Trade Practical**) for the trade of **Aeronautical Structure & Equipment Fitter** under the **Capital Goods & Manufacturing** Sector for ITIs. The CTS trade of Aeronautical Structure and Equipment Fitter and the related instructional materials are provided by Dassault Aviation, the world wide leading aerospace company and RAFALE aircraft manufacturer, in the frame of its extended support to the "Skill India" initiative.

MEDIA DEVELOPMENT COMMITTEE MEMBERS

Expert Name (Mr./Mrs)

Frederic Perez	-	Dassault Aviation Aerospace Company, Skill India
Christelle Carriere	-	Dassault Aviation. Aerospace Company, Skill India
Alain Doriath	-	Dassault Aviation Aerospace Company, Skill India
Guillaume Ancelin	-	Dassault Aviation. Aerospace Company, Skill India
Dominique Geay	-	Dassault Aviation. Aerospace Company, Skill India
Antoine Millet	-	Dassault Aviation. Aerospace Company, Skill India
Patrick Castan	-	Dassault Aviation. Aerospace Company, Skill India
Bruno Penot	-	Dassault Aviation. Aerospace Company, Skill India
Posina Venkata - Rao	-	Dassault Aviation. Aerospace Company, Skill India
Mayur S. Yaul	-	Dassault Aviation. Aerospace Company, Skill India
Julien Henry	-	Dassault Aviation. Aerospace Company, Skill India

NIMI - COORDINATORS

Shri.Nirmalya Nath	-	Deputy Director, NIMI- Chennai - 32.
Shri. V. Gopalakirshnan	-	Manager, NIMI - Chennai -32.

NIMI records its appreciation of the Data Entry, CAD, DTP Operators for their excellent and devoted services in the process of development of this Instructional Material.

NIMI also acknowledges with thanks, the invaluable efforts rendered by all other staff who have contributed for the development of this Instructional Material.

NIMI is grateful to all others who have directly or indirectly helped in developing this IMP.

INTRODUCTION

TRADE PRACTICAL

The trade practical manual is intended to be used in workshop. It consists of a series of practical exercises to be completed by the trainees during the course of the **Aeronautical Structure & Equipment Fitter** trade supplemented and supported by instructions/ informations to assist in performing the exercises. These exercises are designed to ensure that all the skills in compliance with NSQF LEVEL - 4

The manual is divided into Five modules. The distribution of time for the practical in the Five modules are given below.

Module 1	Safety
Module 2	Basic fitting operations
Module 3	Sheet metal basic fitting operation
Module 4	Sheet metal components and assembly
Module 5	Structural panels

The skill training in the shop floor is planned through a series of practical exercises centred around some practical project. However, there are few instances where the individual exercise does not form a part of project.

While developing the practical manual a sincere effort was made to prepare each exercise which will be easy to understand and carry out even by below average trainee. However the development team accept that there is a scope for further improvement. NIMI, looks forward to the suggestions from the experienced training faculty for improving the manual.

TRADE THEORY

The manual of trade theory consists of theoretical information for the course of the Aeronautical Structure & Equipment Fitter Trade. The contents are sequenced according to the practical exercise contained in the manual on Trade practical. Attempt has been made to relate the theoretical aspects with the skill covered in each exercise to the extent possible. This co-relation is maintained to help the trainees to develop the perceptual capabilities for performing the skills.

The Trade theory has to be taught and learnt along with the corresponding exercise contained in the manual on trade practical. The indicating about the corresponding practical exercise are given in every sheet of this manual.

It will be preferable to teach/learn the trade theory connected to each exercise atleast one class before performing the related skills in the shop floor. The trade theory is to be treated as an integrated part of each exercise.

The material is not the purpose of self learning and should be considered as supplementary to class room instruction.

CONTENTS

Exercise No.	Title of the Exercise	Learning Outcome	Page No.
Module 1: Safety			
1.1.01	Importance of trade training, list of tools & machinery used in the trade		1
1.1.02	Safety attitude development of the trainee by educating them to use personal protective equipment (PPE)		4
1.1.03	First aid method and basic training		6
1.1.04	Safe disposal of waste materials like cotton waste, metal chips / burns, etc.	1	12
1.1.05	Hazard identification and avoidance		14
1.1.06	Safety sign for danger, warning, caution and personal safety message		17
1.1.07	Preventive measures for electrical accidents and step to be taken in such accidents		19
1.1.08	Practice on fire extinguishers		21
1.1.09	Safe use of tools and equipment used in the trade	2	22
Module 2: Basic fitting operations			
1.2.10	Selection of material as per application		27
1.2.11	Foreign Object Damage (FOD) and tool inventory		29
1.2.12	Marking out lines, gripping suitably in vice jaws, and hacksawing to given dimensions		30
1.2.13	Sawing different types of metals of different sections		36
1.2.14A	Sawing and filing thin aluminium sheet metal	3	40
1.2.15	Make sheet metal with flanged holes		44
1.2.16A	Filing flat, square and parallel to an accuracy of +/-0.5mm		46
1.2.14B & 16B	Filing steps and notches to accuracy of ± 0.5 mm		49
1.2.14C & 16C	Filing chamfers to accuracy of ± 0.5 mm		53
1.2.14D & 16D	Filing convex radii		57
1.2.14E & 16E	Drilling with drill press		63
1.2.16F	Make countersink, counterbore and spot face	4	67
1.2.16G	Make internal thread		69
1.2.17A	Filing large flat surface and check flatness		72
1.2.17B	Filing square and check using engineer squar		76
1.2.18A	Ream holes with hand reamer		79
1.2.18B	Make components to assembly	5	82
1.2.19	Make assembly with interchangeability		86

Exercise No.	Title of the Exercise	Learning Outcome	Page No.
Module 3: Sheet metal basic fitting operation			
1.3.20	Tensile test N° 1 - Tensile test specimen	1	90
1.3.21	Perform manual drilling		97
1.3.22	Perform manual bending	2	106
1.3.23	Manufacturing parts for riveting		115
1.3.24	Riveting with squeezer	3	120
Module 4: Sheet metal components and assembly			
1.4.25	Part manufacturing - little bended aircraft 1 - ATR		124
1.4.26	Part manufacturing - drilling large diameter		131
1.4.27	Part manufacturing – Rivet gauge manufacturing		134
1.4.28	Part manufacturing - little bended aircraft 2 - fougua magister		136
1.4.29	Part manufacturing - little fuselage - Task 1	4	143
1.4.30	Part manufacturing – Little fuselage assembly		155
1.4.31	Riveting using rivet gun - Training		159
1.4.32	Riveting specimens		164
1.4.33	Parts manufacturing #01 - Training beam sub - assembly		169
1.4.34	Parts manufacturing #02 - Flat panel	5	182
1.4.35	Parts assembly #01 - Training beam - Junction	6	187
Module 5: Structural panels			
1.5.36	Sealant application		198
1.5.37	Sealant specimens		206
1.5.38	Sealant removal	7	209
1.5.39	Sheet metal forming		210
1.5.40	Manufacturing parts #01 – Open box		214
1.5.41	Manufacturing parts #02 – Open box - Closing elements	8	225
1.5.42	Open box assembly		231

LEARNING OUTCOME

On completion of this book you shall be able to

S.No.	Learning Outcome	Ref. Ex.No.
1	Recognize & comply with safe working practices, environment regulation and housekeeping.	1.1.01 to 1.1.08
2	Plan and organize the work to make job as per specification applying different types of basic fitting operation and Check for dimensional accuracy.	1.1.09 to 1.1.09
3	Making basic adjustment of sheet metal and Joining techniques for sheet metal and metal components.	1.2.10 to 1.2.15
4	Produce components by different operations and check accuracy using appropriate measuring instruments	1.2.16A to 1.2.18A
5	Make different fit of components for assembling as per required tolerance observing principle of interchangeability and check for functionality.	1.2.18B to 1.2.19
6	Check the mechanical properties of the different material and interpret the tensile test results	1.3.20
7	Make different types of simple sheet metal components for assembling using hand drill machine and check accuracy using appropriate measuring instruments according to required tolerances ± 0.1 mm	1.3.21 - 22
8	Manufacturing simple sheet metal with bending and check accuracy using appropriate measuring instruments and according to required tolerances ± 0.1 mm. 1	.3.23 - 24
9	Make and assemble components by different handling fitting operations and checking accuracy using appropriate measuring instruments.	1.4.25 - 32
10	Produce straight and curved interchangeable metal components by sheet working operations and check accuracy using appropriate measuring instruments and according to required tolerances ± 0.1 mm.	1.4.33 - 34
11	Manufacturing sheet metal as per drawing and join them by basic riveting observing standard procedure.	1.4.35
12	Perform PR sealant application on structure panels without riveting and perform a tensile test for checking the correct bonding PR sealent application.	1.5.36 - 39
13	manufacturing open and closed riveted box with two different thickness, bended sheets, anchor nuts and electrical bonding.	1.5.40 - 42

SYLLABUS

1st Year

Duration	Reference Learning Outcome	Professional Skill (Trade Practical) (With indicative hour)	Professional Knowledge (Trade Theory)
Professional Skill 84 Hrs; Professional Knowledge 16 Hrs	Plan and organize the work to make job as per specification applying different types of basic fitting operation and check for dimensional accuracy following safety precautions.	<ol style="list-style-type: none"> 1. Importance of trade training, List of tools & Machinery used in the trade. 2. Safety attitude development of the trainee by educating them to use Personal Protective Equipment (PPE). 3. First Aid Method and basic training. 4. Safe disposal of waste materials like cotton waste, metal chips/burrs etc. 5. Hazard identification and avoidance. 6. Safety signs for Danger, Warning, caution & personal safety message. 7. Preventive measures for electrical accidents & steps to be taken in such accidents. 8. Use of Fire extinguishers. (42 hrs) 	<p>English technical vocabulary related to the task. All necessary guidance to be provided to the newcomers to become familiar with the working of Industrial Training Institute system including stores procedures.</p> <p>Soft Skills: its importance and Job area after completion of training. Importance of safety and general precautions observed in the in the industry/shop floor.</p> <p>Introduction of First aid.</p> <p>Operation of electrical mains.</p> <p>Introduction of PPEs. Response to emergencies e.g. ; power failure, fire, and system failure.</p> <p>Importance of housekeeping & good shop floor practices.</p> <p>Introduction to 5S concept & its application. Occupational Safety & Health: Health, Safety and Environment guidelines, legislations & regulations as applicable. (08 hrs)</p>
		<ol style="list-style-type: none"> 9. Identification of tools & equipment as per desired specifications for marking & sawing. 10. Selection of material as per application. 11. Visual inspection of raw material for rusting, scaling, corrosion etc. 12. Marking out lines, gripping suitably in vice jaws, hacksawing to given dimensions 13. Sawing different types of metals of different sections. (42 hrs) 	<p>English technical vocabulary related to the task. Aircraft Safety Practices: Foreign Object Damage, Inventory of tools before and after intervention, Traceability of specific tools used. Linear measurements- its units, dividers, callipers, hermaphrodite, center punch, dot punch, their description and uses of different types of hammers. Description, use and care of 'V' Blocks, marking off table. (08 hrs)</p>
Professional Skill 105 Hrs Professional Knowledge 20 Hrs	Perform making of basic adjustment of sheet metal and Joining techniques for sheet metal and metal components.	<ol style="list-style-type: none"> 14. Make basic adjustment of sheet metal using Aluminum 2024, size 150 mm x 150 mm, thickness 1.5 mm, by performing operations of: <ul style="list-style-type: none"> - Tracing by using ruler, Vernier calipers, Vernier height gauge - Cutting process with Hack saw - Deburring (files handling) - Checking criteria and acceptance in accordance with geometric tolerances: perpendicularity, parallelism, flatness, angle 	<p>English technical vocabulary related to the task. Aircraft Safety Practices: Maintenance of tools, Clean the workstation.</p> <p>Metallic Material Science: properties - Physical & Mechanical Non-Ferrous metals: Aluminum Non-Ferrous Alloys: Aluminum series Introduction of Engineering Drawing reading plan. Introduction of Metrology</p>

		<ul style="list-style-type: none"> - Appropriate Measuring Instrument. [Vernier Caliper, Vernier Height Gauge, Cast Iron surface plates, Vee blocks, Square, Micrometer](42 hrs) 	Vernier and height gauge handling and maintenance. File handling, Machining file, Tracing, Sawing, Vice. (08hrs)
		<p>15. Make basic adjustment of sheet metal with flanged holes using Aluminum 2024, size 150 mm x 200 mm, thickness 2 mm, by performing operations of:</p> <ul style="list-style-type: none"> - Tracing - Debiting - Deburring - Adjustment of the parts with geometric tolerances: perpendicularity, parallelism, flatness, rounded - Making flanged holes - Appropriate Measuring Instrument. [Vernier calipers, Vernier Height Gauge, Cast Iron surface plates, Veeblocks, Square, Micrometer](63 hrs) 	English technical vocabulary related to the task. Aircraft Safety Practices: Means of protection of the aircraft working area. Metallic Material Science: properties - Physical & Mechanical Non-Ferrous metals: Aluminum Non-Ferrous Alloys: Aluminum series File holding, Machining file, Tracing, Sawing, Vice. Bench vice construction, types, uses, care & maintenance, vice clamps, hacksaw frames and blades, specification, description, types and their uses, method of using hacksaws. Hydraulic press for Flanges holes. (12hrs)
Professional Skill 190 Hrs; Professional Knowledge 36 Hrs	Produce components by different operations and check accuracy using appropriate measuring instruments.	<p>16. Adjustment N°1 Perform deburring operations on a 10 mm Aluminum block (Al 2024), size 100mm x 50 mm, with geometric constraints (flatness, angle, rounded) by:</p> <ul style="list-style-type: none"> - Tracing by using ruler, Vernier calipers, Vernier height gauge, marking blue, Dial comparator - Cutting process with Hack saw - Deburring - Perform adjustment operations with geometric and machining tolerances: - Drilling by using depth gauge and vertical drill machine - Fitting process by using files - Counter boring Appropriate Measuring Instrument. [Vernier Caliper, Vernier Height Gauge, Cast Iron surface plates, Vee blocks, Square, Dial comparator, Micrometer](63 hrs) 	English technical vocabulary related to the task. Human Factors: Human Performance and Limitations, Social Psychology, Factors Affecting Performance, Physical Environment, Physical work; Repetitive tasks; Visual inspection; Complex systems, Communication within and between teams; Human Error, Hazards in the Workplace. Vertical drill handling and maintenance (counterboring, countersinking) Marking- Prussian blue, their special application, description. Use, care and maintenance of scribing block. Surface plate and auxiliary marking equipment, angle plates, parallel block, description, types, uses, accuracy, care and maintenance. (12 hrs)
		<p>17. Adjustment N°2 Perform adjustment operations on a 20 mm Aluminum block (Al 2024), size 50 mm x 50 mm, with geometric constraints by:</p> <ul style="list-style-type: none"> - Tracing by using ruler, Vernier, height gage, marking blue, dial comparator - Cutting process with Hack saw - Deburring 	English technical vocabulary related to the task. Human Factors: Brief History of Aviation, General aircraft description, Aerodynamic notions, how does an aircraft fly? Counter sink, counter bore and spot facing- tools and nomenclature, Reamer- material, types (Hand and machine reamer). (12 hrs)

		<ul style="list-style-type: none"> - Drilling by using Vernier depth gauge and vertical drill machine - Fitting process (using files) - Countersinking - Checking criteria and acceptance - Appropriate Measuring Instrument. [Vernier Caliper, Vernier Height Gauge, Cast Iron surface plates, Vee blocks, Square, dial comparator, Micrometer](63 hrs) 	
		<p>18. Adjustment N°3 Perform adjustment operations on a 10 mm Aluminum block (Al 2024), size 50 mm x 50 mm, with geometric constraints by: - Tracing by using ruler, Vernier, Vernier height gage, marking blue, dial comparator</p> <ul style="list-style-type: none"> - Cutting process with Hack saw - Deburring - Drilling by using depth gauge and vertical drill machine- - Fitting process (using files) - Reaming - Countersinking - Performing thread cutting - Checking criteria and acceptance - Appropriate Measuring Instrument. [Vernier Caliper, Vernier Height Gauge, Cast Iron surface plates, Vee blocks, Square, Dial comparator, "GO no GO" gauge, Micrometer] (64 hrs) 	English technical vocabulary related to the task. Human Factors: Aircraft main parts (fuselage, wing and empennage, engine and pylons, Landing gear, equipment's) Taps and Thread Standards.(12hrs)
Professional Skill 65 Hrs; Professional Knowledge 12 Hrs	Make different fit of components for assembling as per required tolerance observing principle of interchangeability and check for functionality.	<p>19. Adjustment N°4 Make an assembly (size 100 mm x 50 mm) with Aluminum (Al 7075) and Stainless steel parts of different thicknesses, with geometric constraints by performing operations of:</p> <ul style="list-style-type: none"> - Drilling - Fitting process (using files) - Countersinking - Reaming - Performing thread cutting - Filling with liquid shim (Aluminum filler) - Clearances measurement. / - Appropriate Measuring Instrument. [Vernier Caliper, Square, Dial comparator, "GO no GO" gauge, Micrometer, Clearance Gauge](63 hrs) 	English technical vocabulary related to the task. Metallic Material Science: properties - Physical & Mechanical Non-Ferrous metals: Aluminum Non-Ferrous Alloys: Aluminum series Screw threads: terminology, parts, types and their uses. Screw pitch gauge. Clearance and tolerances, liquid shim handling and maintenance. (12 hrs)
Professional Skill 21 Hrs; Professional Knowledge 04 Hrs	Check the mechanical properties of the different materials and interpret the tensile test results.	<p>20. Tensile test N°1 Using Aluminum (2024, 5086, 7075), AISI 316L Stainless steel, Titanium TA6V, Carbon Steel, tank 250 mm x 20 mm, make 3 tensile specimens by:</p> <ul style="list-style-type: none"> - Tracing with geometric constraints 	English technical vocabulary related to the task. Metallic Material Science: properties - Physical & Mechanical Types - Ferrous & Non-Ferrous, difference between Ferrous and Non-Ferrous metals, introduction

		<ul style="list-style-type: none"> - Cutting process with Hack saw - Fitting process (using files) - Interpretation of tensile test results(21 hrs) 	<p>of Iron, Steel, difference between Iron, steel and Cast iron, Alloy steel, carbon steel, stainless steel, Non-Ferrous metals: magnesium, titanium, copper, nickel. Screw threads: terminology, parts, types and their uses. Screw pitch gauge.</p> <p>Clearance and tolerances, liquid shim uses. (4 hrs)</p>
Professional Skill 21 Hrs; Professional Knowledge 04 Hrs	Make different types of simple sheet metal components for assembling using hand drill machine and check accuracy using appropriate measuring instruments according to required tolerances ± 0.1 mm.	<p>21. Perform manual drilling operations on Aluminum 2024, stainless steel 316L and titanium TA6V (size 400 mm x 200 mm for each) by:</p> <ul style="list-style-type: none"> - Tracing, Cutting process with Hack saw, fitting process (using files) on each sheet - Tracing for rivet pitch and edge distance calculation and drilling - Drilling - Counter drilling - Deburring - Temporary fitting (clamping pin) Appropriate Measuring Instrument. [Vernier Height Gauge, Cast Iron surface plates, Vee blocks, Square, Micrometer] (21 hrs) 	<p>English technical vocabulary related to the task. Metallic Material Science: properties - Physical & Mechanical Types - Ferrous & Non-Ferrous, difference between Ferrous and Non-Ferrous metals, introduction of Iron, Steel, difference between Iron, steel and Cast iron, Alloy steel, carbon steel, stainless steel, Non-Ferrous metals: magnesium, titanium, copper, nickel. Drill-material, types, parts and sizes for metallic materials. Drill angle-cutting angle for different materials, cutting speed feed. R.P.M. for different materials.</p> <p>Drill holding devices- material, construction and their uses. Calculation of pitch and edge distance, importance of the pitch and the edge distance. (04 hrs)</p>
Professional Skill 21 Hrs; Professional Knowledge 04 Hrs	Manufacture simple sheet metal with bending and check accuracy using appropriate measuring instruments and according to required tolerances ± 0.1 mm. A A S / N 1 4 0 1	<p>22. Perform manual bending operations on Aluminum 5086 (size 100 mm x 80 mm) by:</p> <ul style="list-style-type: none"> - Tracing, Cutting process with Hacksaw, fitting process (using files) - Bending following drawings instructions - Appropriate Measuring Instrument [Vernier Caliper, Vernier Height Gauge, Cast iron surface plates, Vee blocks, Square, Micrometer] (21 hrs) 	<p>English technical vocabulary related to the task. Metallic Material Science: properties - Physical & Mechanical Types - Ferrous & Non-Ferrous, difference between Ferrous and Non-Ferrous metals, introduction of Iron, Steel, difference between Iron, steel and Cast iron, Alloy steel, carbon steel, stainless steel, Non-Ferrous metals: magnesium, titanium, copper, nickel. Assembling techniques such as aligning, bending, fixing, mechanical jointing, threaded jointing, sealing, and torquing. Bending handling and maintenance. (04 hrs)</p>
Professional Skill 21 Hrs; Professional Knowledge 04 Hrs	Manufacture sheet metal as per drawing and Join them by basic riveting observing standard procedure.	<p>23. Perform drilling operations on Aluminum sheet (2024, 7075), size 400 mm x 200 mm by:</p> <ul style="list-style-type: none"> - Tracing, Cutting process with belt saw - Fitting process (using files) - Using hand drill machine 	<p>English technical vocabulary related to the task. Metallic Material Science: properties - Physical & Mechanical Types - Ferrous & Non-Ferrous, difference between Ferrous and Non-Ferrous metals, introduction of Iron, Steel,</p>

		<ul style="list-style-type: none"> - Deburring - Pitch and edge distance calculation - Temporary fitting (clamping pin) - Dial Comparator using - Self-check by using rivet gauge - Appropriate Measuring Instrument. [Vernier Caliper, Vernier Height Gauge, Cast Iron surface plates, Vee blocks, Square, Dial comparator, Rivet gauge, Micrometer] (25 hrs) 	<p>difference between Iron, steel and Cast iron, Alloy steel, carbon steel, stainless steel, Non- Ferrous metals: magnesium, titanium, copper, nickel.</p>
		<p>24. Perform squeeze riveting or "C" squeeze on thickness 3 mm and angle profile (countersunk head and round head rivet with different dash diameters) by:</p> <ul style="list-style-type: none"> - Manual countersinking - Dial Comparator using - Self-check by using rivet gauge - Appropriate Measuring Instrument. [Vernier Caliper, Vernier Height Gauge, Cast Iron surface plates, Vee blocks, Square, Dial comparator, Rivet gauge, Micrometer](21 hrs) 	<p>Sheet holders pins: material, construction, types, accuracy and uses. Basic riveting operations with squeeze et C riveting tools, care, maintenance, Solid Rivet definition, types, sizes, materials, length calculation. (04 hrs)</p>
<p>Professional Skill 125 Hrs; Professional Knowledge 25 Hrs</p>	<p>Make and assemble components by different handling fitting operations and checking accuracy using appropriate measuring instruments.</p>	<p>25. Part manufacturing (example: little bended aircraft): Perform adjustment operations on Aluminum sheet (Al 5086), size 200 mm x 100 mm, thickness of 1.5 mm by:</p> <ul style="list-style-type: none"> - Tracing with template, Cutting process with belt saw, Fitting process (using files) - Using hand drill machine / - Deburring - Temporary fitting (clamp) - Rivet pitch and edge distance calculation <p>26. Perform deburring on the manufactured part.</p> <p>27. Appropriate Measuring Instrument. [Vernier Caliper, Vernier Height Gauge, Micrometer] (25hrs)</p> <p>28. Part manufacturing (example: little bended aircraft): Perform duplicate operations of the previous work (Aluminum sheet (Al 5086), size 200 mm x 100 mm, thickness of 1.5 mm)</p> <ul style="list-style-type: none"> - Adjustment - Tracing - Cutting process with belt saw - Fitting process (using files) - Appropriate Measuring Instrument. [Vernier Caliper, Vernier Height Gauge, Micrometer](21 hrs) 	<p>Metallic Material Science: properties - Physical & Mechanical Types - Ferrous & Non-Ferrous, difference between Ferrous and Non-Ferrous metals, introduction of Iron, Steel, difference between Iron, steel and Cast iron, Alloy steel, carbon steel, stainless steel, Non-Ferrous metals: magnesium, titanium, copper, nickel. Assembling techniques such as aligning, bending, fixing, mechanical jointing, threaded jointing, sealing and torquing. Fixing, mechanical jointing, threaded jointing, sealing and torquing. Sheet holders pins: material, construction, types, accuracy and uses. Perform basic riveting operations viz., squeeze etc., riveting tools, care, maintenance, specification, description, types and their uses, method of using. (04 hrs)</p>

		<p>29. Part manufacturing (Example: little bended aircraft):Using Aluminum 5086, size 200 mm x 100 mm, perform operations of:</p> <ul style="list-style-type: none"> - Drilling, Counter drilling - Temporary fitting (clamping pin) - Rivet pitch and edge distance calculation - Bending - Appropriate Measuring Instrument. [Vernier, Height Gauge, Micrometer] (21 hrs) 	<p>English technical vocabulary related to the task. Metallic Material Science: properties - Physical & Mechanical Types - Ferrous & Non-Ferrous, difference between Ferrous and Non-Ferrous metals, introduction of Iron, Steel, difference between Iron, steel and Cast iron, Alloy steel, carbon steel, stainless steel, Non- Ferrous metals: mag nesium, titanium, copper, nickel. Assembling techniques such as aligning, bending, fixing, mechanical jointing, threaded jointing, sealing, and torquing. (04 hrs)</p>
		<p>30. Part manufacturing (example: little bended aircraft):Using Aluminum 5086, size 200 mm x 100 mm, perform operations of:</p> <ul style="list-style-type: none"> - Bending - Deburring, Temporary fitting - Riveting (squeeze riveting, "C" squeeze) - Self-check by using rivet gauge - Appropriate Measuring Instrument. [Rivet gauge, etc.] (21 hrs) 	<p>English technical vocabulary related to the task. Metallic Material Science: properties - Physical & Mechanical Types - Ferrous & Non-Ferrous, difference between Ferrous and Non-Ferrous metals, introduction of Iron, Steel, difference between Iron, steel and Cast iron, Alloy steel, carbon steel, stainless steel, Non- Ferrous metals: magnesium, titanium, copper, nickel. Sheet holders pins: material, construction, types, accuracy and uses. Perform basic riveting operations viz., squeeze etc., riveting tools, care, maintenance, specification, description, types and their uses, method of using. (05 hrs)</p>
		<p>31. Using Aluminum 2024, size 250 mm x 20 mm, perform operations of:</p> <ul style="list-style-type: none"> - Tracing - Cutting process with belt saw - Fitting process (using belt sanding machine) - Using hand drill machine - Deburring - Temporary fitting (clamping pin) - Manual and micrometric countersinking - Self-check by using rivet gauge - Riveting using rivet gun (different diameters, different thicknesses, angle profile, countersunk head and round head rivets) Appropriate Measuring Instrument. [Vernier Caliper, Vernier Height Gauge, Cast Iron surface plates, Vee blocks, Square, Dial indicator, Rivet gauge, Micrometer] (21 hrs) 	<p>English technical vocabulary related to the task. Metallic Material Science:properties - Physical & Mechanical Types - Ferrous & Non-Ferrous, difference between Ferrous and Non-Ferrous metals, introduction of Iron, Steel, difference between Iron, steel and Cast iron, Alloy steel, carbon steel, stainless steel, Non-Ferrous metals: Magnesium, titanium, copper, nickel. Sheet holders pins: material, construction, types, accuracy and uses. Riveting operations with Rivet gun tools, care, maintenance, specification, description, types and their uses, handling and maintenance. (04 hrs)</p>

<p>Professional Skill 50 Hrs; Professional Knowledge 07 Hrs</p>	<p>Produce straight and curved interchangeable metal components by sheet metal working operations and check accuracy using appropriate measuring instruments and according to required tolerance ± 0.1 mm.</p>	<p>32. Tensile test N°2: Using Aluminum 2024, tank 250mmx20mm, make 3 riveted tensile specimens by:</p> <ul style="list-style-type: none"> - Tracing with geometric constraints - Cutting process with belt saw - Fitting process (using files) - Riveting - Perform tensile tests(20 hrs) <p>33. Structure parts manufacturing N°1: Using Aluminum 2024, sheet size 400 mm x 150mm, thickness of 1.5 mm, bending radius 4,5, manufacture primary parts by performing operations of</p> <ul style="list-style-type: none"> - Tracing - Cutting process with belt saw - Bending - Drilling with hand drill machine - Flanged holes Appropriate Measuring Instrument. [Vernier Caliper, Vernier Height Gauge, Cast Iron surface plates, Vee blocks, Square, Micrometer](21 hrs) <p>34 Structure parts manufacturing N°2: (Example: frames, stringers, splices) Using Aluminum 2024, sheet size 2000 mm x1000 mm thickness of 1.5 mm or 2 mm, bending radius 4,5 , manufacture primary parts with geometric constraints (angle, rounded, flatness)</p> <ul style="list-style-type: none"> - Tracing - Cutting process with belt saw - Bending - Drilling with hand drill machine - Flanged holes Appropriate Measuring Instrument. [Vernier Caliper, Vernier Height Gauge, Cast Iron surface plates, Vee blocks, Square, Micrometer] (21 hrs) 	<p>English technical vocabulary</p> <p>related to the task. Basic study of stress-strain curve for MS. (RDM) Stress, strain, ultimate strength, factor of safety. Physical properties of engineering metal: colour, weight, structure, and conductivity, magnetic, fusibility, specific gravity. method of using. (04 hrs)</p> <p>English technical vocabulary related to the task. Temperature measuring instruments. Specific heats of solids & liquids. Assembling techniques such as aligning, bending, fixing, mechanical jointing, threaded jointing, sealing, and torquing. (03 hrs)</p> <p>English technical vocabulary related to the task. Thermal Conductivity, Heat loss and heat gain. Average Velocity, Acceleration & Retardation.</p> <p>Related problems. Sheet metal working techniques such as growing, shrinking. (04 hrs)</p>
<p>Professional Skill 21 Hrs; Professional Knowledge 04 Hrs</p>	<p>Manufacture sheet metal as per drawing and Join them by basic riveting observing standard procedure.</p>	<p>35. Assembly of structure parts (by team of 2 trainees): Using the previous manufactured parts, with Aluminum 2024, sheet size 2000 mm x 1000 mm, perform operations of:</p> <ul style="list-style-type: none"> - Drilling with hand drill machine - Riveting using rivet gun, drilling grid, countersunk head and round head rivets, different diameters of rivets - Self-check by using rivet gauge - Joogling sheet metal Appropriate Measuring Instrument. [Vernier Caliper, Rivet Gauge](21 hrs) 	<p>English technical vocabulary related to the task.</p> <p>Circular Motion: Relation between circular motion and Linear motion, Centrifugal force, centripetal force.</p> <p>Drill- material, types, parts and sizes for metallic materials.</p> <p>Drill angle-cutting angle for different materials, cutting speed feed. R.P.M. for different materials.</p> <p>Drill angle holding devices material, construction and their uses. (04 hrs)</p>

Professional Skill 84 Hrs; Professional Knowledge 16 Hrs	Perform PR sealant application on structure panels without riveting and perform a tensile test for checking the correct bonding PR sealant application.	<p>36. PR sealant application: Using Aluminum 2024, sheet size 400 mm x 200 mm, perform operations of:</p> <ul style="list-style-type: none"> - Tracing, Cutting process with belt saw with geometric constraints - Drilling with hand drill machine - Counter drilling - Pickling - Temporary fitting - PR sealant application Appropriate Measuring Instrument. [Vernier Caliper](21 hrs) 	<p>English technical vocabulary related to the task.</p> <p>Aircraft Safety Practices:</p> <p>Identification of ingredients with limited shelf life, how to store them and discard them.</p> <p>PR sealant types, uses, curing, pot life, storage, care and maintenance (04 hrs)</p>
		<p>37. Tensile Test N°3: Using Aluminum 2024, sheet size 250 mm x 20 mm, perform operations of:</p> <ul style="list-style-type: none"> - Bonding PR sealant application with surface preparation on tensile specimens - Tensile tests on the realized specimens <p>Appropriate Measuring Instrument. [Tensile test machine](21 hrs)</p>	<p>English technical vocabulary related to the task.</p> <p>PR physical properties, surfaces treatment associated. (04 hrs)</p>
		<p>38. Rivets removal Using: Aluminum 2024, sheet size 2000 mm x 1000 mm, perform rivets removals by manual drilling and using center punch and pin drift. (21 hrs)</p>	<p>English technical vocabulary related to the task. Solid Rivet definition, types, sizes, removal operations. (04 hrs)</p>
		<p>39. Structure parts manufacturing N°3: Using Aluminum 2024, sheet size 300 mm x 100 mm, thickness of 1.5 mm, adjust curved parts by performing:</p> <ul style="list-style-type: none"> - Tracing, Cutting process with Hack saw with geometric constraints - Debiting - Deburing - Bending - Adjustment and shrinking sheet metal - Clearances measurement Appropriate Measuring Instrument. [Vernier Caliper, Vernier Height Gauge, Cast Iron surface plates, Vee blocks, Square, Clearance gauge, Micrometer](21 hrs) 	<p>English technical vocabulary related to the task. Sheet metal working techniques such as growing, shrinking.</p> <p>Shrinking machine handling and maintenance. (04 hrs)</p>

Professional Skill 42 Hrs; Professional Knowledge 08 hrs	Manufacture open and closed riveted box with two different thicknesses, bended sheets, anchor nuts and electrical bonding	<p>40. Open riveted box manufacturing: Using Aluminum 2024, different thicknesses sheet, size 400 mm x 400 mm, perform operations of :</p> <ul style="list-style-type: none"> - Bending - Drilling, counter drilling - Countersinking - Riveting - Flanged hole (2 spars with thickness 1.5mm, 2 spars with thickness 2.5mm) Appropriate Measuring Instrument. [Vernier Caliper, Rivet gauge](8 hrs) 	<p>English technical vocabulary related to the task.</p> <p>Sheet holders pins: material, construction, types, accuracy and uses. Perform riveting operations viz., Rivet gun tools, care, maintenance, specification, description, types and their uses, method of using. (02 hrs)</p>
		<p>41. Open riveted box manufacturing on dedicated support, perform operations of:</p> <ul style="list-style-type: none"> - Assemblies of anchor nuts - Assemblies of equipment and electrical harness supports - Electrical Bonding using electrical bonding brush Appropriate Measuring Instrument. [Ohmmeter] (12 hrs) 	<p>English technical vocabulary related to the task. Bonding definition, uses, protection.</p> <p>Bonding brush handling and maintenance(03 hrs)</p>
		<p>42. Riveted closed profile manufacturing : Using Aluminum 2024, Titanium TA6V, sheet size 400 mm x 300 mm, Perform operations of:</p> <ul style="list-style-type: none"> - Rolling, - Shaping, - Bending, - Jogging - Drilling (with angle drill machine), counter drilling - Countersinking - Riveting on sheets of different thicknesses, - Pickling - PR sealant application, / - Making flanged holes / - Making movable access door <p>Appropriate Measuring Instrument. [Vernier Caliper, Vernier Height Gauge, Cast Iron surface plates, Vee blocks, Square, Rivet gauge, Micrometer] (22 hrs)</p>	<p>English technical vocabulary related to the task. Drill material, types, parts and sizes for metallic materials. Drill angle cutting angle for different materials, cutting speed feed. R.P.M. for different materials. Drill angle holding devices material, construction and their uses. (03hrs)</p>

Importance of trade training, list of tools & machinery used in the trade

Objectives: At the end of this exercise you shall be able to

- identify the tools and equipment used in fitter section
- record the names of tools, do's and don't of each tool
- record the names of the industries where the fitters are employed.

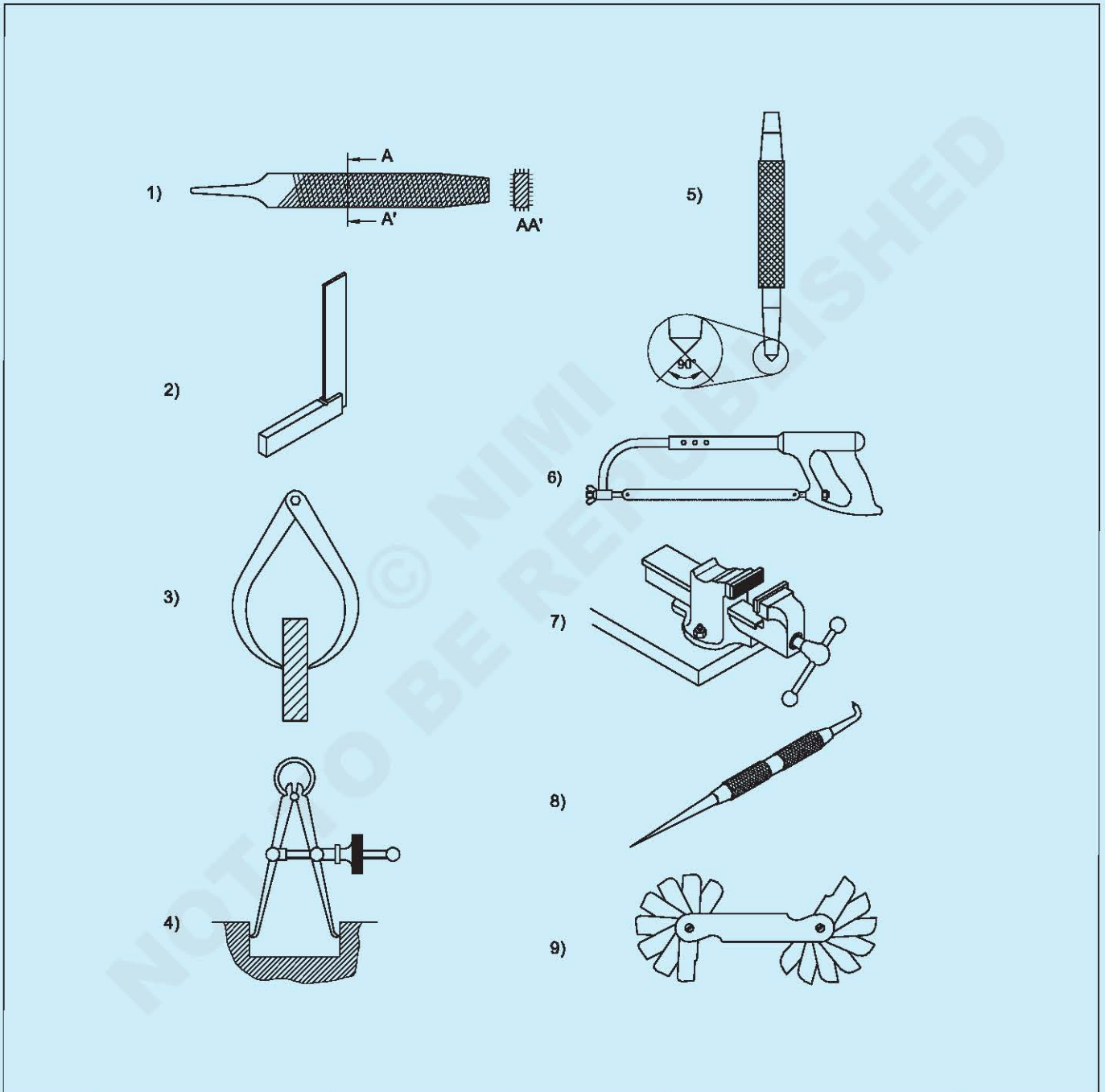

--	--	--	--	--	--	1.1.01
NO.OFF	STOCK SIZE	SEMI-PRODUCT	MATERIAL	PROJECT NO.	PART NO.	EX. NO
SCALE	IDENTIFICATION OF TOOLS, AND EQUIPMENTS				DEVIATIONS	TIME 1 Hr
					CODE NO. AFN1101E1	

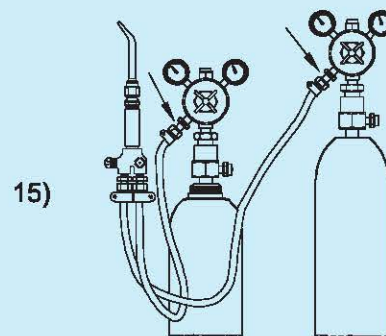
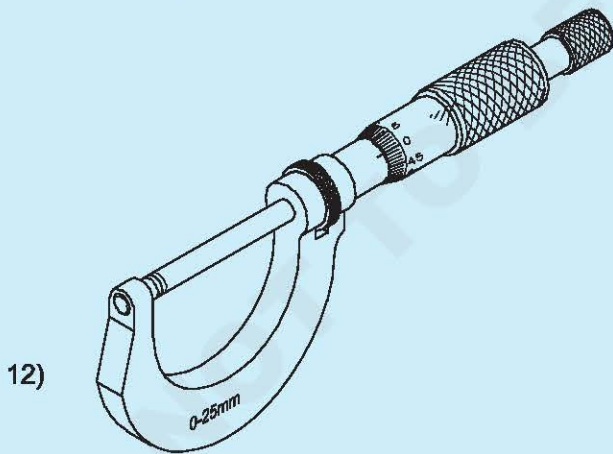
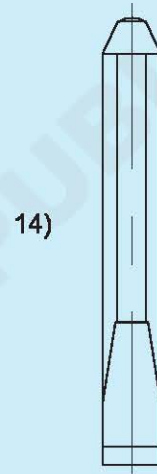
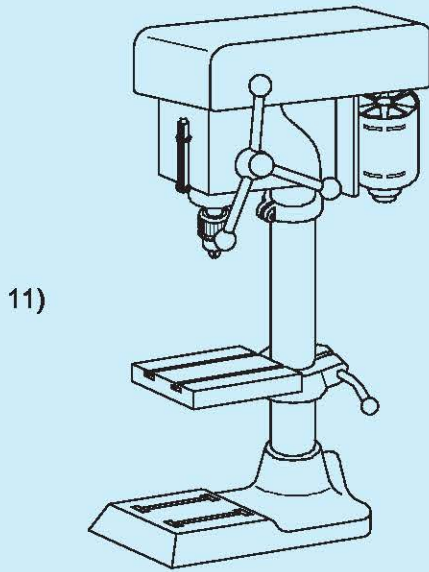
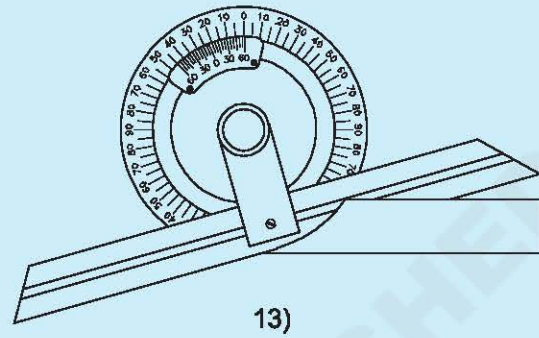
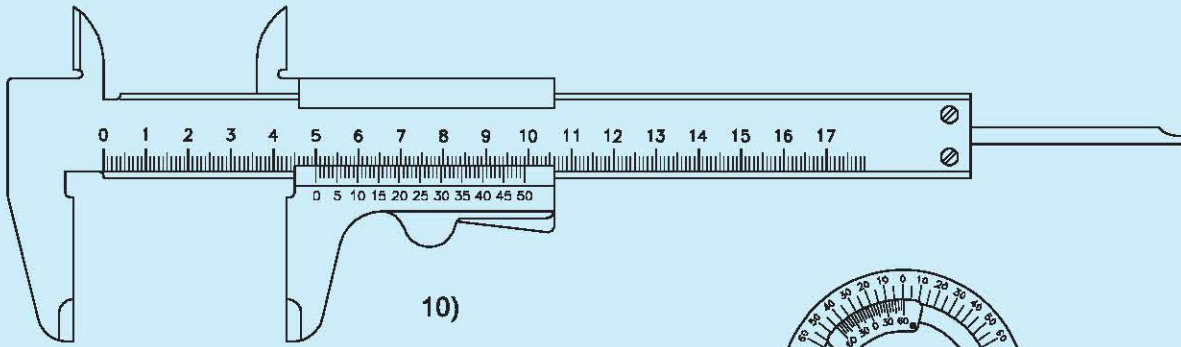

-	-	-	-	-	-	1.1.01
NO.OFF	STOCK SIZE	SEMI-PRODUCT	MATERIAL	PROJECT NO.	PART NO.	EX. NO.
SCALE	IDENTIFICATION OF TOOLS, AND EQUIPMENTS				DEVIATIONS	TIME:
					CODE NO. AFN1101E2	

Job Sequence

Instructor shall display all the tools and equipment in the section and brief their names, uses and the safety point to be observed for each tool and equipment.

- Trainees will note down all the displayed tools names, uses and the precaution to be observed while working with each tool.
- Record it in Table 1
- Get it checked by the instructor.

Table 1

Sl.No	Name of tool/equipment	Uses	Precaution to be observed (Do's and Don't)
1			
2			
3			
4			
5			
6			
7			
8			
9.			
10			
11			
12			
13			
14			
15			

Instructor shall brief the role of a fitter in industries. Emphasis more on the assembly shop by providing the names of the private and public sector industries, where the fitters are largely employed. Ask the trainees to note down the names of the industries.

Safety attitude development of the trainee by educating them to use personal protective equipment (PPE)

Objectives: At the end of this exercise you shall be able to

- identify personal protective devices
- interpret the different types of personal protective devices
- identify occupational hazards and the corresponding potential hazards.



Fig 1



Fig 2

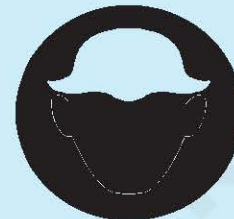

Fig 3



Fig 4

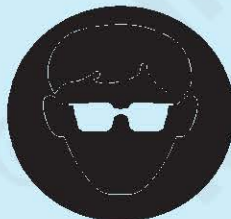

Fig 5



Fig 6



Fig 7



Fig 8



Fig 9

--	--	--	--	--	--	1.1.02
NO.OFF	STOCK SIZE	SEMI-PRODUCT	MATERIAL	PROJECT NO.	PART NO.	EX. NO.
SCALE	IDENTIFY THE CATEGORIES OF PERSONAL PROTECTIVE DEVICE				DEVIATIONS	TIME: 5HOURS
					CODE NO. AFN1102E1	

PROCEDURE

TASK1: Identify the personal protective devices

- 1 Read and interpret the visuals of personal protective equipment on real devices or from the charts.
- 2 Identify and select personal protective equipment used for different types of protection.
- 3 Write the name of the PPE and the corresponding type of protection and the hazards in table 1

The instructor shall display the different types of personal protective equipment or charts and explain how to identify and select the PPE devices suitable for the work and ask the trainees to note down the hazards and type of protection in the Table 1

Table1

S.No.	NameofthePPE	Hazards	Type of protection
1			
2			
3			
4			
5			
6			
7			
8			
9.			

Get it checked by your instructor.

TASK 2: Interpret the different types of personal protective devices

Instructor may brief the various types of occupational hazards and their causes.

- 1 Identify the occupational hazard and the corresponding situation with the potential harm and record it in Table 2

Table 2

S.No.	Source or potential harm	Type of occupational hazards
1	Noise	
2	Explosive	
3	Virus	
4	Sickness	
5	Smoking	
6	Noncontroldevice	
7	Noearthing	
8	Poorhousekeeping	

Fill up and get it checked by your instructor.

First aid method and basic training

Objectives: At the end of this exercise you shall be able to

- rescue breathing for an unconscious victim of different condition
- perform treatment for stopping of bleeding.

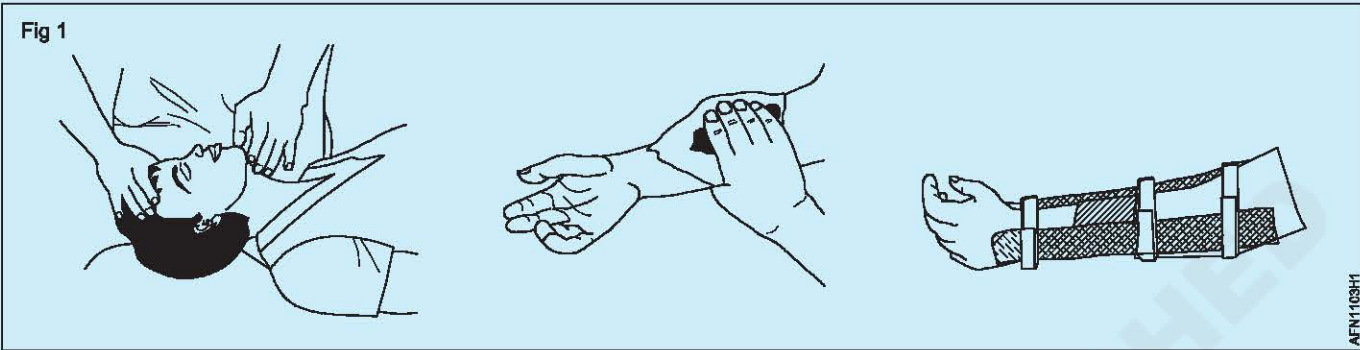

Assumption - For easy manageability, Instructor may arrange the trainees in group and ask each group to perform one method of resuscitation.

PROCEDURE

TASK 1: Prepare the victim to receive artificial respiration

- 1 Loosen the tight clothing which may interfere with the victim's breathing.
- 2 Remove any foreign materials or false teeth from his mouth and keep the victim's mouth open.
- 3 Bring the victim safely to the level ground, taking necessary safety measures.
- 4 Start artificial respiration immediately without delay. Do not waste too much time in loosening the clothes or trying to open the tightly closed mouth.
- 5 Avoid violent operations to prevent injury to the internal parts of the victim.
- 6 Send word for a doctor immediately.

TASK 2: Resuscitate the victim by Nelson's arm - Lift back pressure method

Nelson's arm-lift back pressure method must not be used in case there are injuries to the chest and belly.

- 1 Place the victim prone (that is face down) with his arms folded with the palms one over the other and the head resting on his cheek over the palms. Kneel on one or both knees near the victim's hand. Place your hands on the victim's back beyond the line of the armpits, with your fingers spread outwards and downwards, thumbs just touching each other as in Fig 1.

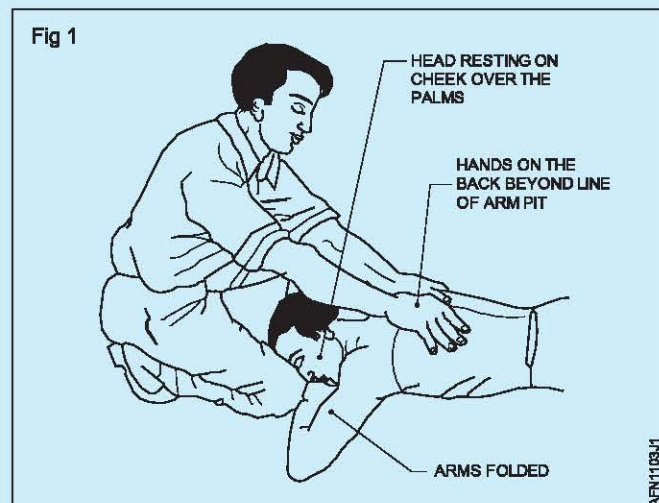

- 2 Gently rock forward keeping your arms straight until they are nearly vertical, and steadily pressing the victim's back as shown in Fig 2 to force the air out of the victim's lungs.

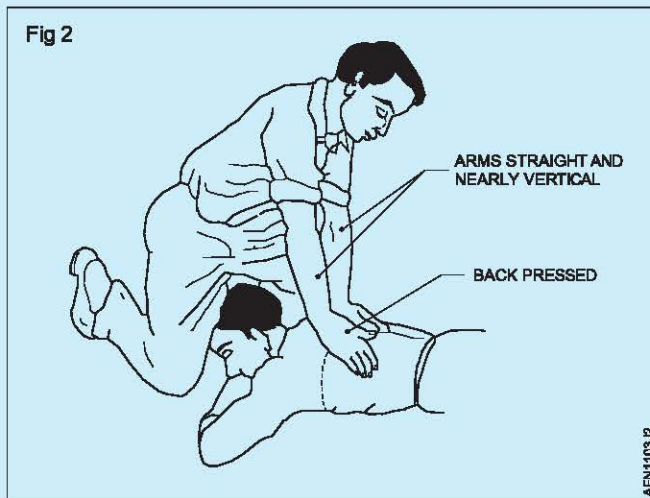

- 3 Synchronise the above movement of rocking backwards with your hands sliding downwards along the victim's arms, and grasp his upper arm just above the elbows as shown in Fig 3. Continue to rock backwards.

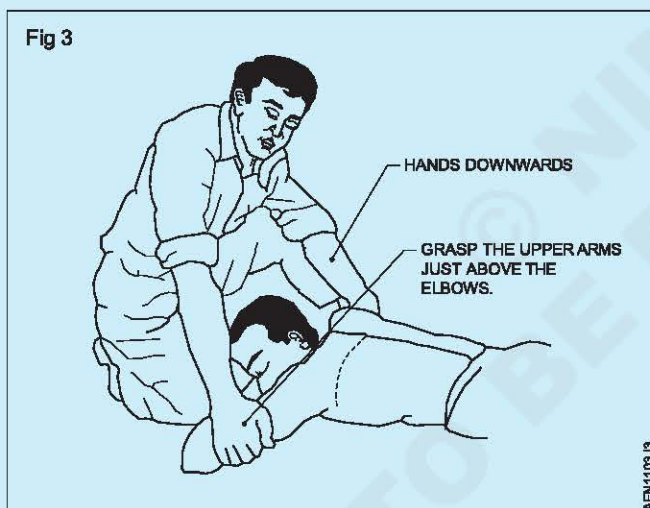

- 4 As you rock back, gently raise and pull the victim's arms towards you as shown in Fig 4 until you feel tension in his shoulders. To complete the cycle, lower the victim's arms and move your hands up to the initial position.

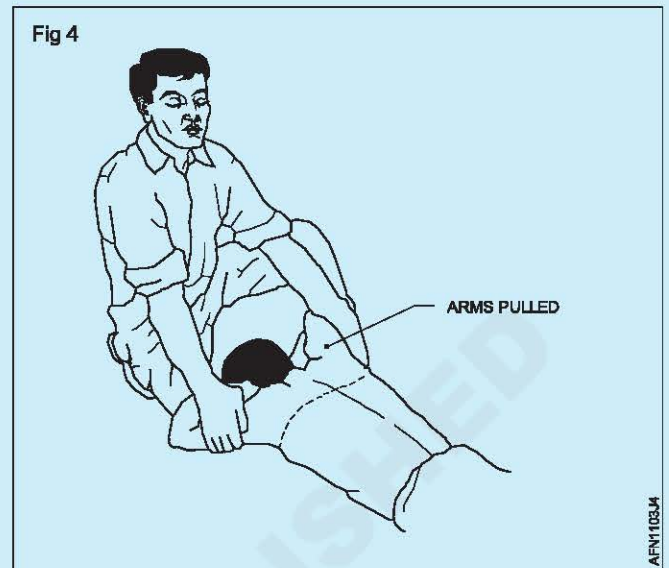

- 5 Continue artificial respiration till the victim begins to breathe naturally. Please note, in some cases, it may take hours.
- 6 When the victim revives, keep the victim warm with a blanket, wrapped up with hot water bottles or warm bricks; stimulate circulation by stroking the insides of the arms and legs towards the heart.
- 7 Keep him in the lying down position and do not let him exert himself.

TASK 3: Resuscitate the victim by Schafer's method

Do not use this method in case of injuries to victim on the chest and belly.

- 1 Lay the victim on his belly, one arm extended direct forward, the other arm bent at the elbow and with the face turned sideward and resting on the hand or forearm as shown in Fig 5.
- 2 Kneel astride the victim, so that his thighs are between your knees and with your fingers and thumbs positioned as in Fig 5.

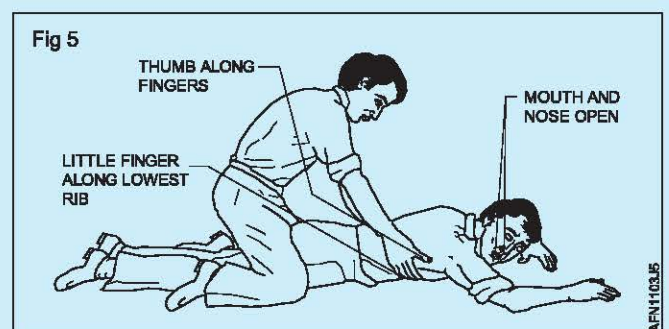

- With the arms held straight, swing forward slowly so that the weight of your body is gradually brought to bear upon the lower ribs of the victim to force the air out of the victim's lungs as shown in Fig 6

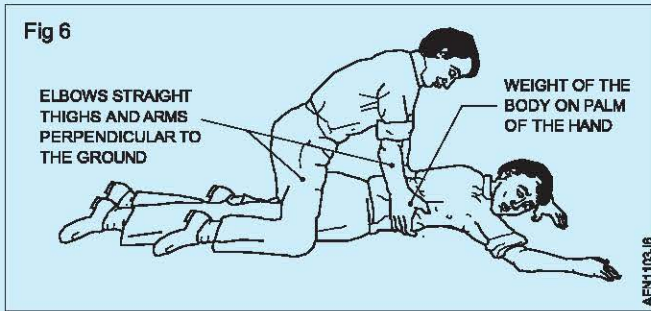

- Now swing backward immediately removing all the pressure from the victim's body as shown in Fig 7, thereby, allowing the lungs to fill with air.

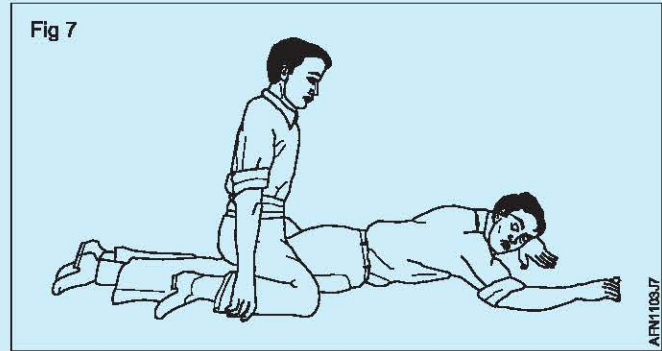

- After two seconds, swing forward again and repeat the cycle twelve to fifteen times a minute.
- Continue artificial respiration till the victim begins to breathe naturally.

TASK 4: Resuscitate the victim by mouth-to-mouth method

- Lay the victim flat on his back and place a roll of clothing under his shoulders to ensure that his head is thrown well back. (Fig 8)

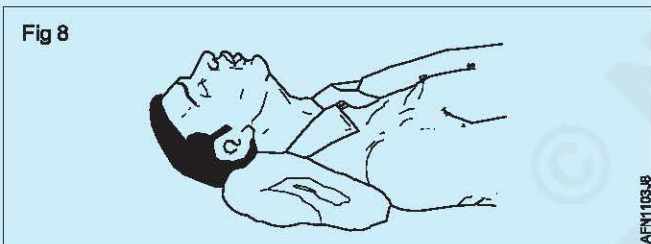

- Tilt the victim's head back so that the chin points straight upward. (Fig 9.)

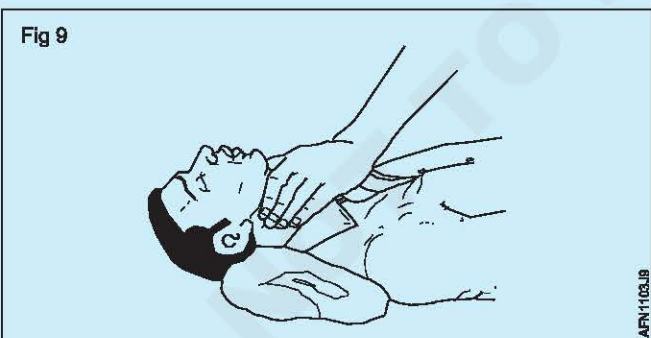

- Grasp the victim's jaw as shown in Fig 10, and raise it upward until the lower teeth are higher than the upper teeth; or place fingers on both sides of the jaw near the ear lobes and pull upward. Maintain the jaw position throughout the artificial respiration to prevent the tongue from blocking the air passage.

- Take a deep breath and place your mouth over the victim's mouth as shown in Fig 11 making airtight contact. Pinch the victim's nose shut with the thumb

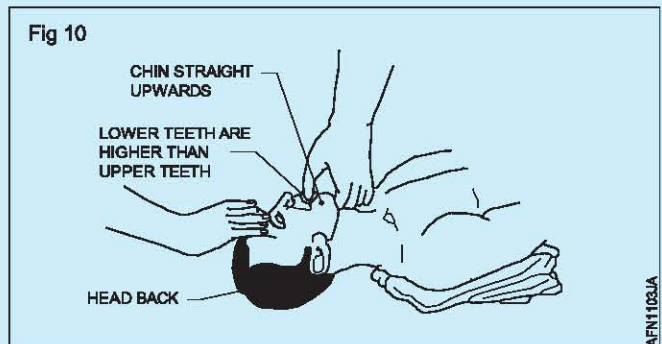

and forefinger. If you dislike direct contact, place a porous cloth between your mouth and the victim's. For an infant, place your mouth over his mouth and nose.

- Blow into the victim's mouth (gently in the case of an infant) until his chest rises. Remove your mouth and release the hold on the nose, to let him exhale, turning your head to hear the rushing out of air. The first 8 to 10 breathings should be as rapid as the victim responds, thereafter the rate should be slowed to about 12 times a minute (20 times for an infant).

If air cannot be blown in, check the position of the victim's head and jaw and recheck the mouth for obstructions, then try again more forcefully. If the chest still does not rise, turn the victim's face down and strike his back sharply to dislodge obstructions.

Sometimes air enters the victim's stomach as evidenced by a swelling stomach. Expel the air by gently pressing the stomach during the exhalation period.

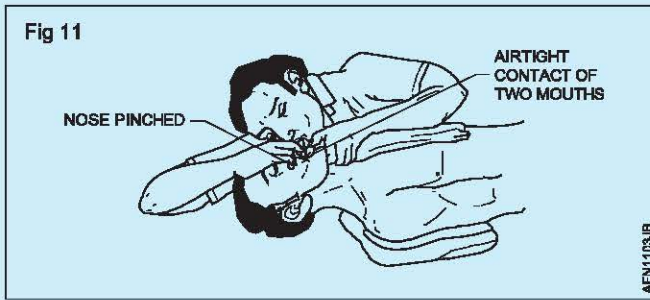

TASK 5: Resuscitate the victim by Mouth-to-Nose method

Use this method when the victim's mouth will not open, or has a blockage you cannot clear.

- 1 Use the fingers of one hand to keep the victim's lips firmly shut, seal your lips around the victim's nostrils and breathe into him. Check to see if the victim's chest is rising and falling. (Fig 12)
- 2 Repeat this exercise at the rate of 10 - 15 times per minute till the victim responds.
- 3 Continue this exercise till the arrival of the doctor.

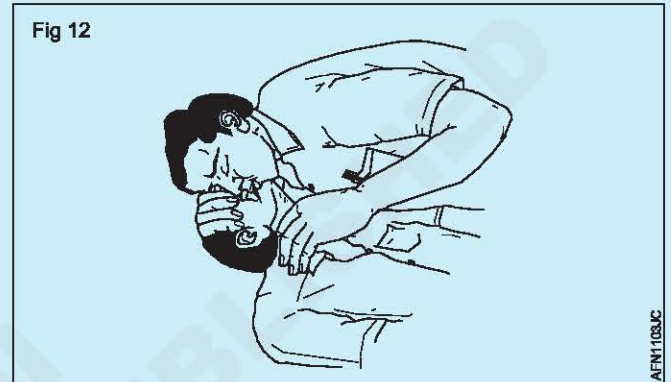

TASK 6: Resuscitate a victim who is under cardiac arrest (CPR) cardio pulmonary

In cases where the heart has stopped beating, you must act immediately.

- 1 Check quickly whether the victim is under cardiac arrest.

Cardiac arrest could be ascertained by the absence of the cardiac pulse in the neck (Fig 13), blue colour around lips and widely dilated pupil of the eyes.

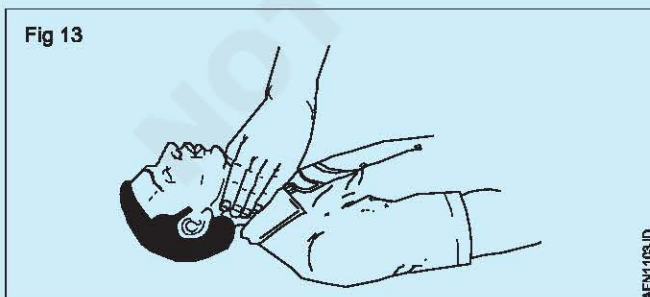

- 2 Lay the victim on his back on a firm surface.
- 3 Kneel alongside facing the chest and locate the lower part of the breastbone. (Fig 14)

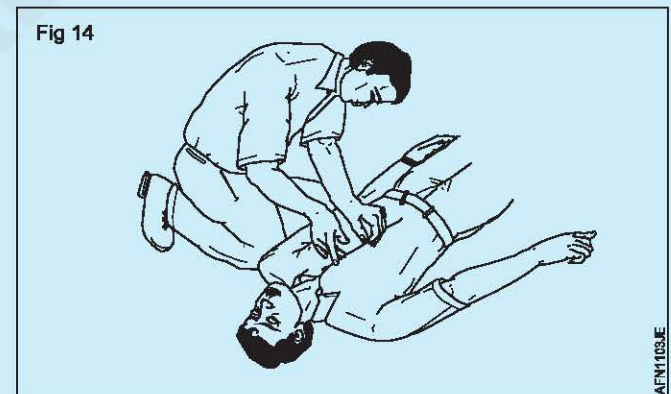

- 4 Place the palm of one hand on the centre of the lower part of the breastbone, keeping your fingers off the ribs. Cover the palm with your other hand and lock your fingers together as shown in Fig 15

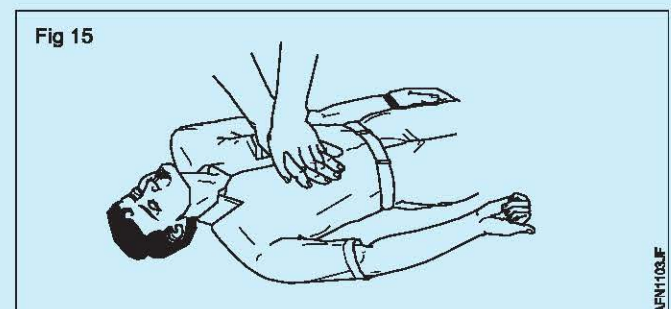

- Keeping your arms straight, press sharply down on the lower part of the breastbone; then release the pressure. (Fig 16)

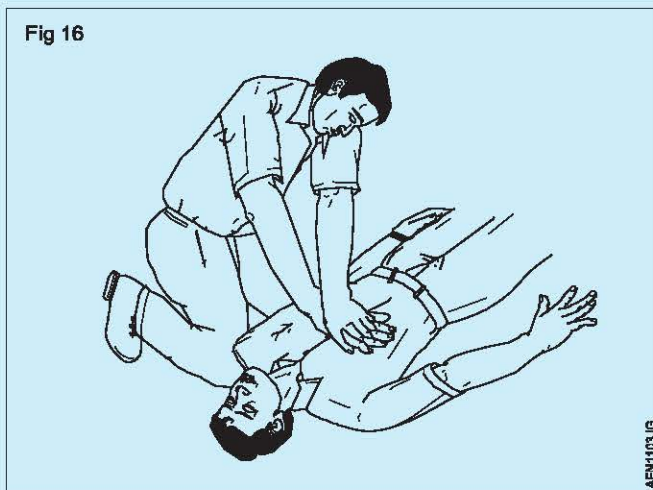

- Repeat step 5, fifteen times at the rate of at least once per second.
- Check the cardiac pulse. (Fig 17)

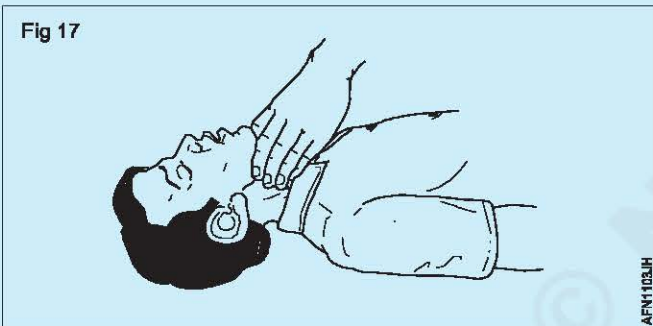

- Move back to the victim's mouth to give two breaths (mouth-to-mouth resuscitation). (Fig 18)
- Continue with another 15 compressions of the heart followed by a further two breaths of mouth-to-mouth resuscitation, and so on, check the pulse at frequent intervals.

- As soon as the heartbeat returns, stop the compressions immediately but continue with mouth-to-mouth resuscitation until natural breathing is fully restored.

- Place the victim in the recovery position as shown in Fig 19. Keep him warm and get medical help quickly.

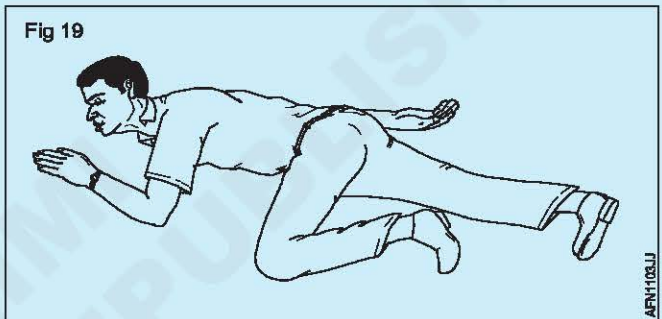
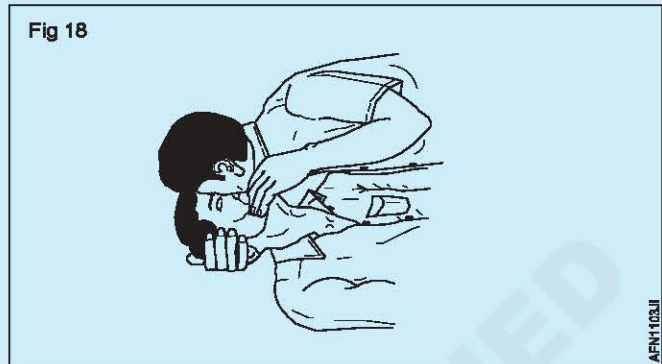

Other steps

- Send word for a doctor immediately.
- Keep the victim warm with a blanket, wrapped up with hot water bottles or warm bricks; stimulate circulation by stroking the insides of the arms and legs towards the heart.

TASK 7: Treatment for bleeding victim

- Determine the location of the bleeding.
- Elevate the injured area above the heart if possible.
- Apply direct pressure to the bleeding area with sterile cloth.
- Keep the pressure on for 5 seconds.
- Check to see if the bleeding has stopped if not apply further pressure for 15 minutes.
- Clean the wound.
- Bandage the wound with pad of soft material. (Fig 20)
- Advise victim to take treatment from doctor.

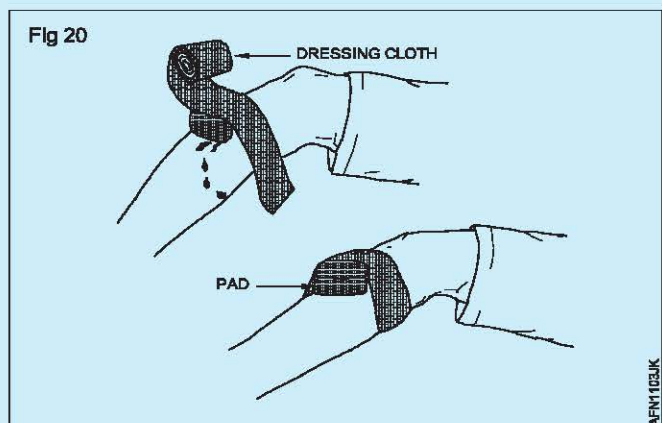

First aid method and basic training

- Objectives:** At the end of this exercise you shall be able to
- identify and segregate the waste material in workshop
 - arrange the waste material in different bins.

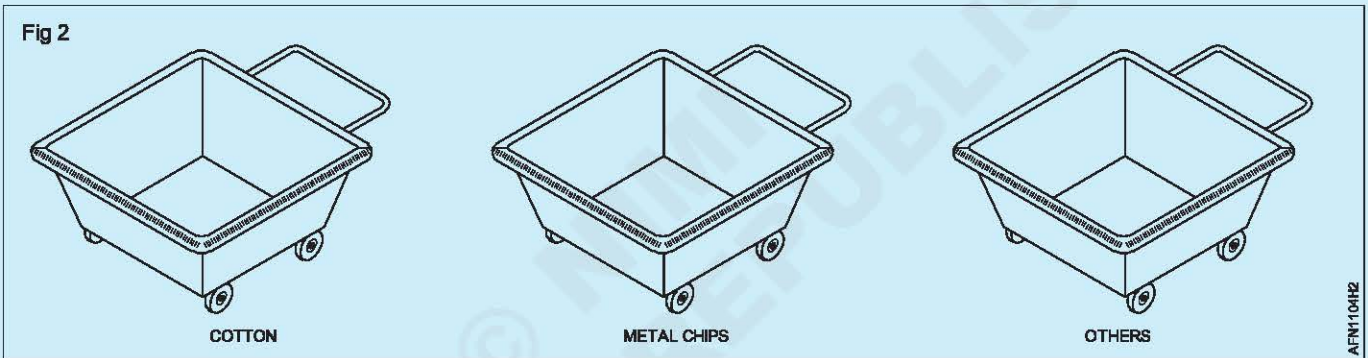
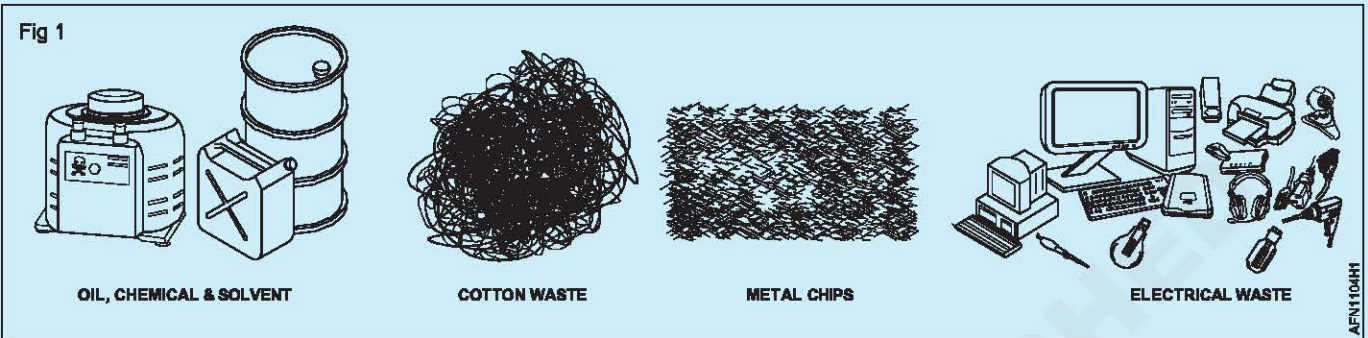

Job Sequence

- Separate the cotton waste.
- Collect the chips by hand shovel with the help of brush. (Fig 2)
- Clean the floor, if oil is spilled.
- Separate the cotton waste material and store it in the bin provided to store the waste cotton material. (Fig 2)
- Similarly store each category of metal chip in separate bins.

**Do not handle the chip by bare hand
There may be different metal chips. So separate the chip according to metal.**

Each bin should have name of the material.

Identify the material given in fig 1 and fill in table1.

Table1

S No.	Name of the material
1	
2	
3	
4	
5	

Hazard identification and avoidance

Objectives: At the end of this exercise you shall be able to

- identify the occupational hazards
- suggest suitable methods to avoid occupational hazards.

1



WORKING BARE FOOT IN SHOP FLOOR

2

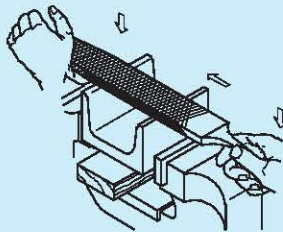

USING FILE WITHOUT HANDLE

3

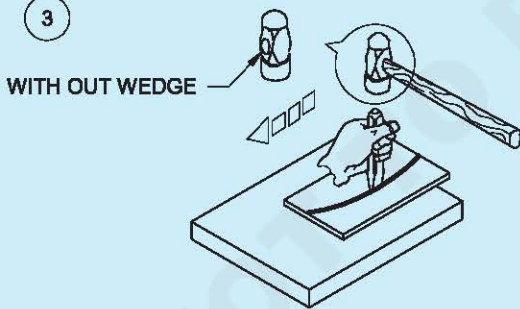

STRIKING ON CHISEL HEAD WITH BALL PEIN HAMMER WITHOUT WEDGE

4

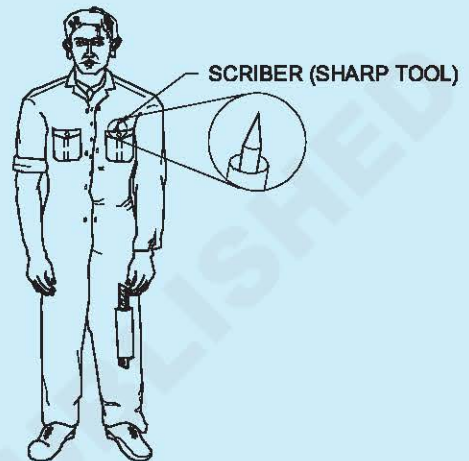

KEEPING SCRIBER SHARP EDGE OPEN IN POCKET

5

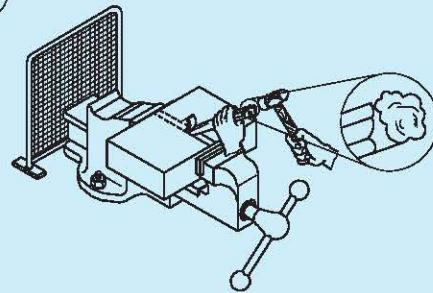

CHIPPING METAL SURFACE WITH MUSHROOM HEAD CHISEL

-	-	-	-	-	-	1.1.05
NO.OFF	STOCK SIZE	SEMI-PRODUCT	MATERIAL	PROJECT NO.	PART NO.	EX. NO.
SCALE : NTS	HAZARD IDENTIFICATION AND AVOIDANCE				DEVIATIONS	TIME : 2hrs
					CODE NO. AFN1105E1	

6

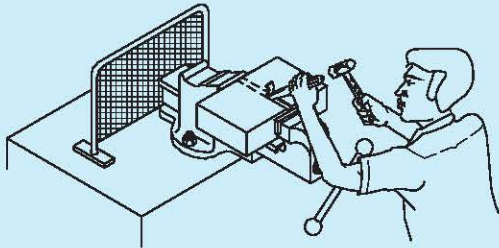

CHIPPING ON METAL SURFACE WITHOUT SAFETY GOGGLES

7

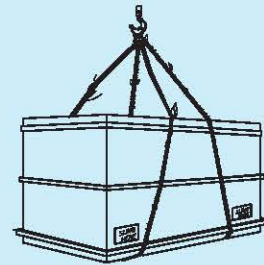

LIFTING LOAD WITH DAMAGED SLINGS

8



NO OBSTACLE WHILE MOVING THE LOAD

9

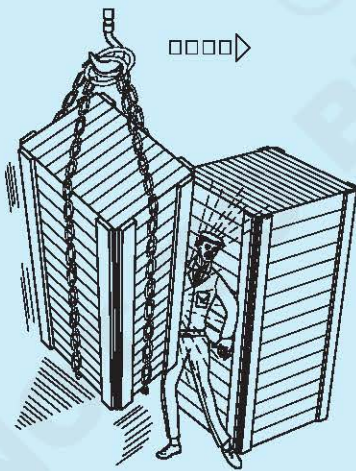

LIFTING A LOAD WHILE PEOPLE WORKING NEARBY

10

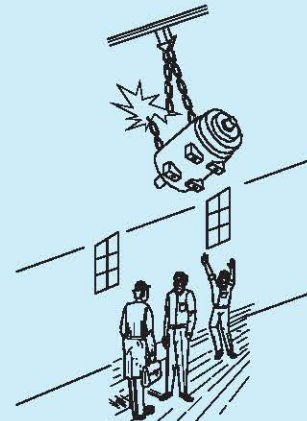

STANDING BELOW A SUSPENDED LOAD

-	-	-	-	-	-	1.1.05
NO.OFF	STOCK SIZE	SEMI-PRODUCT	MATERIAL	PROJECT NO.	PART NO.	EX. NO.
SCALE: NTS	HAZARD IDENTIFICATION AND AVOIDANCE				DEVIATIONS	TIME:
					CODE NO. AFN1105E2	

Job Sequence

The instructor shall emphasise the importance of hazard and avoidance to the students and insist them to follow properly.

- Study the drawing of industrial hazards.
- identify the type of hazards.

- Name the hazards against their names.
- Record the hazards and avoidance in Table 1
- Study the drawing of industrial hazards.

Table 1

S.No.	Identification of hazards	Avoidance
1		
2		
3		
4		
5		
6		
7		
8		
9.		
10		

- Get it checked by your instructor.

Safety sign for danger, warning, caution and personal safety message

Objectives: At the end of this exercise you shall be able to

- identify the basic categories of safety sign
- record the meaning of safety sign in the table given.



Fig 1



Fig 2



Fig 3

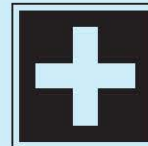

Fig 4



Fig 5



Fig 6



Fig 7



Fig 8



Fig 9



Fig 10



Fig 11



Fig 12



Fig 13



Fig 14



Fig 15

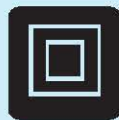

Fig 16



Fig 17



Fig 18



Fig 19



Fig 20

-	-	-	-	-	-	1.1.06
NO.OFF	STOCK SIZE	SEMI-PRODUCT	MATERIAL	PROJECT NO.	PART NO.	EX. NO.
SCALE	IDENTIFY THE CATEGORIES OF THE SAFETY SIGN				DEVIATIONS	TIME: 1Hr
					CODE NO. AFN1106E1	

Job Sequence

Instructor shall provide various safety signs, chart categories and explain their meaning, description. Ask the trainee to identify the sign and record in Table 1

- Identify the safety sign from the chart.
- Record the name of the category in Table 2
- Mention the meaning description of the safety sign in Table 1

S.No.	Basic Categories/Safety sign	Meaning - Description
1		
2		
3		
4		
5		
6		
7		
8		
9.		
10		
11		
12		
13		
14		
15		
16		
17		
18		
19.		
20		

- Get it checked by your instructor.

Preventive measures for electrical accidents and step to be taken in such accidents

Objective: At the end of this exercise you shall be able to
 • rescue a person from live wire.

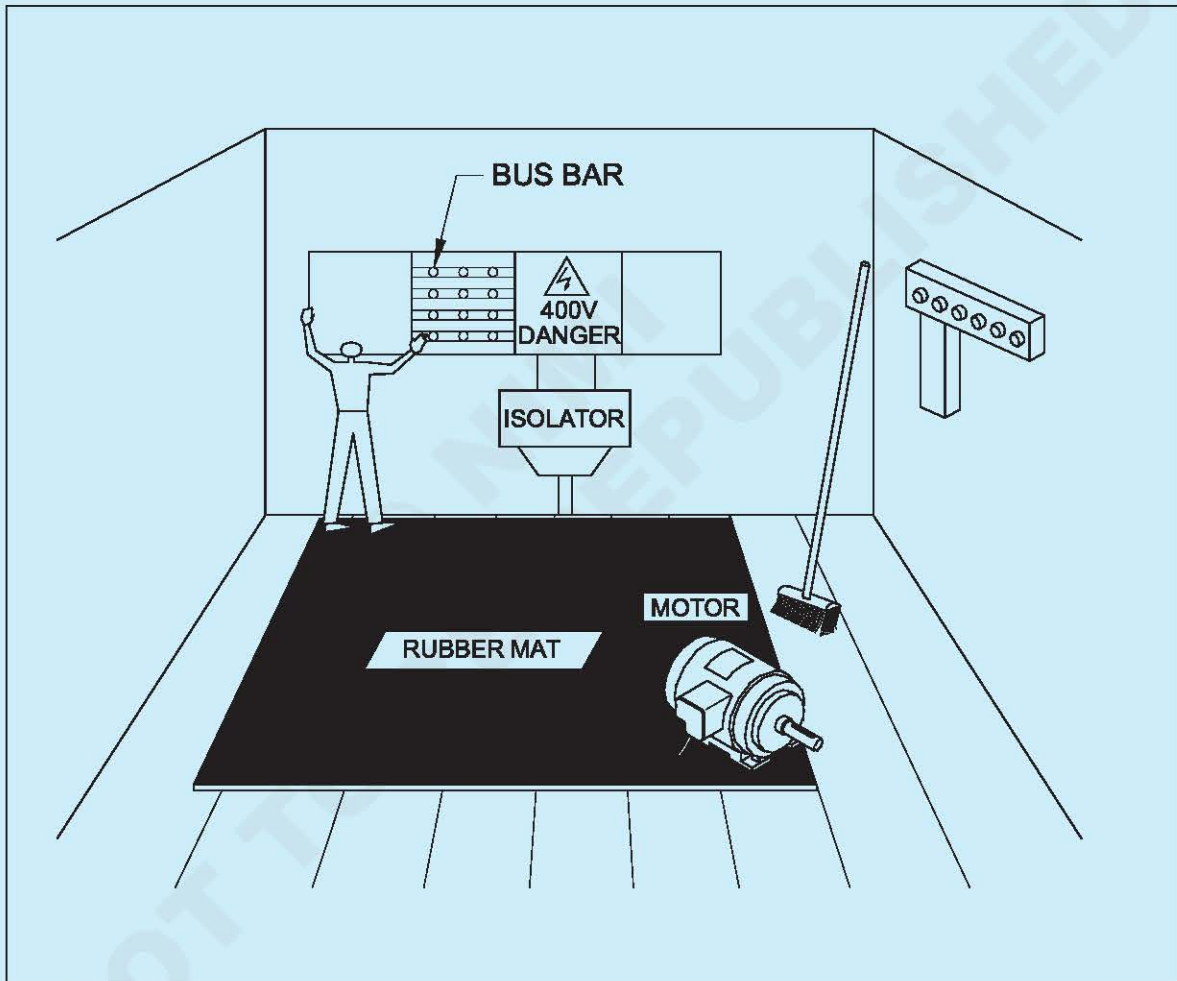

-	-	-	-	-	-	1.1.07
NO.OFF	STOCK SIZE	SEMI-PRODUCT	MATERIAL	PROJECT NO.	PART NO.	EX. NO.
SCALE	PREVENTIVE MEASURES FOR ELECTRICAL ACCIDENTS				DEVIATIONS	TIME : 2 HOURS
					CODE NO. AFN1107E1	

Job Sequence

Disconnecting a person (mock victim) from a live supply (simulated)

- Observe the person (mock victim) receiving an electric shock. Interpret the situation quickly.
- Remove the victim safely from the 'live' equipment by disconnecting the supply or using one of the items of insulating material.

Do not run to switch off the supply that is far away.

Do not touch the victim with bare hands until the circuit is made dead or the victim is moved away from the equipment.

Push or pull the victim from the point of contact of the live equipment, without causing serious injury to the victim. (Fig 1)

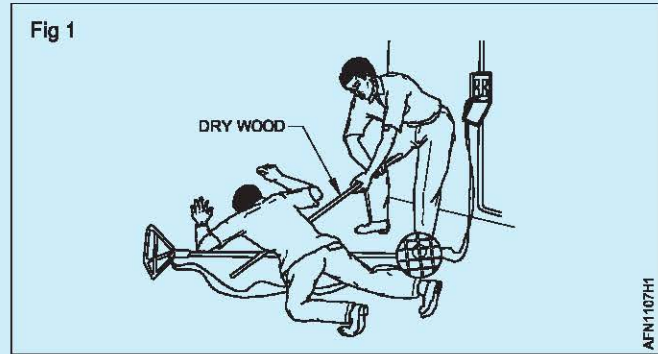

- Move the victim physically to a nearby place.
- Check for the victim's natural breathing and consciousness.
- Take steps to apply respiratory resuscitation if the victim is unconscious and not breathing.

Practice on fire extinguishers

- Objectives:** At the end of this exercise you shall be able to
- select the fire extinguisher according to the type of fire
 - operate the fire extinguisher
 - operate the fire extinguisher
 - extinguish the fire.

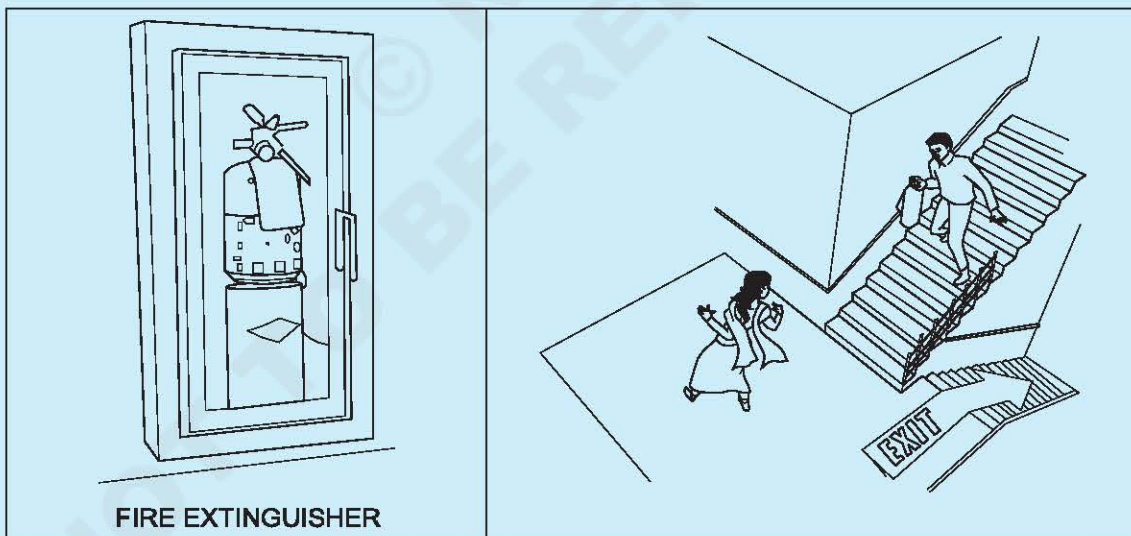
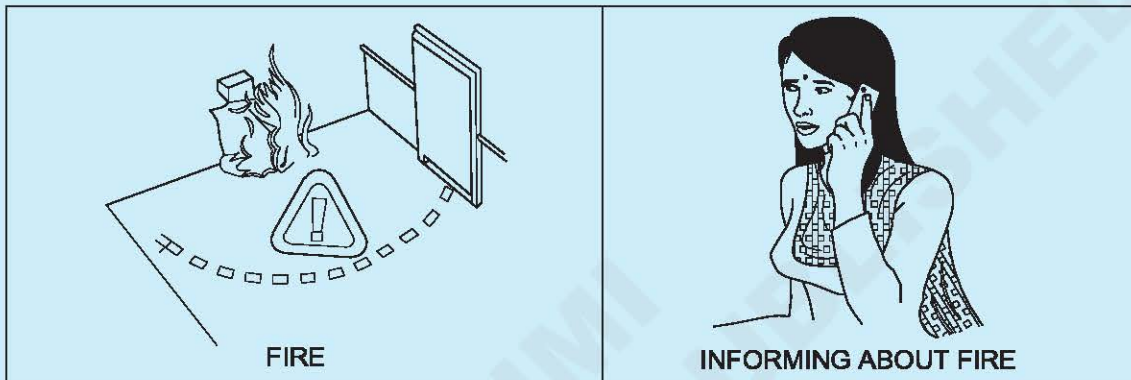



--	--	--	--	--	--	1.1.08
NO.OFF	STOCK SIZE	SEMI-PRODUCT	MATERIAL	PROJECT NO.	PART NO.	EX. NO.
SCALE		PRACTICE ON FIRE EXTINGUISHER			DEVIATIONS	TIME : 7 HOURS
					CODE NO. AFN1108E1	

Job Sequence

- Alert people surrounding by shouting fire, fire, fire when observe fire.
- Inform fire service or arrange to inform immediately.
- Open emergency exit and ask them to go away.

Do not allow people to go nearer to the fire.

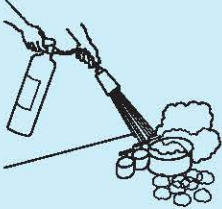
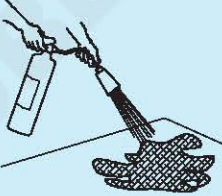
Table 1

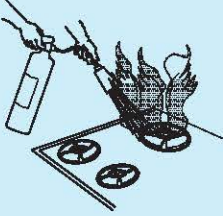
<p>Class 'A'</p>	<p>Wood, paper, cloth, solid material</p>	
<p>Class 'B'</p>	<p>Oil based fire (grease, gasoline, oil) & liquefiable solids</p>	
<p>Class 'C'</p>	<p>Gas and liquefied gases</p>	
<p>Class 'D'</p>	<p>Metals and electrical equipment</p>	

Assume the fire is 'B' type (flammable liquefiable solids).

- Select CO₂ (carbon dioxide) fire extinguisher
- Locate and pick up CO₂ fire extinguisher. Check for its expiry date.
- Break the seal. Fig 1

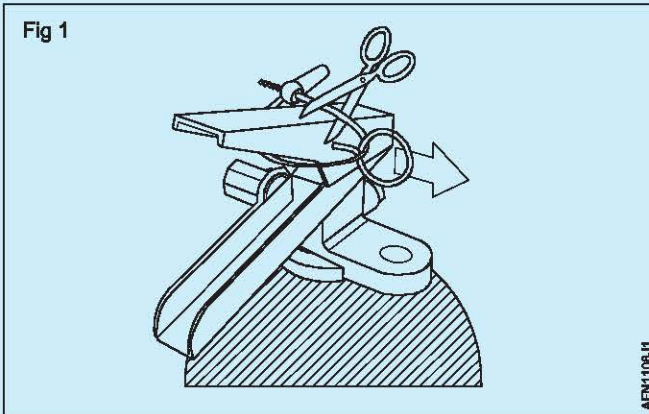

- Pull the safety pin from the handle (Fig 2) (Pin located at the top of the fire extinguisher) (Fig 2)

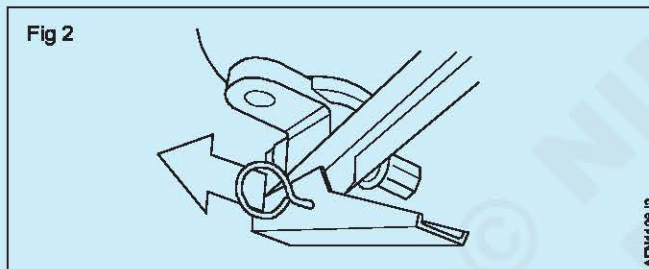

- Aim the extinguisher nozzle or hose at the base of the fire (this will remove the source of fuel fire) (Fig 3)

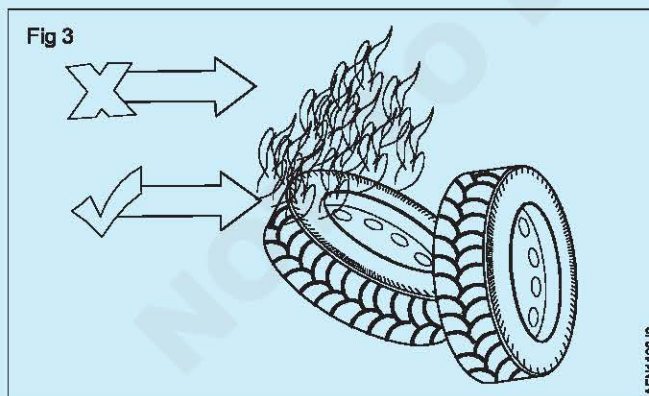

Keep yourself low.

- Squeeze the handle lever slowly to discharge the agent (Fig 4)
- Sweep side to side approximately 15 cm over the fuel fire until the fire is put off. (Fig 4)

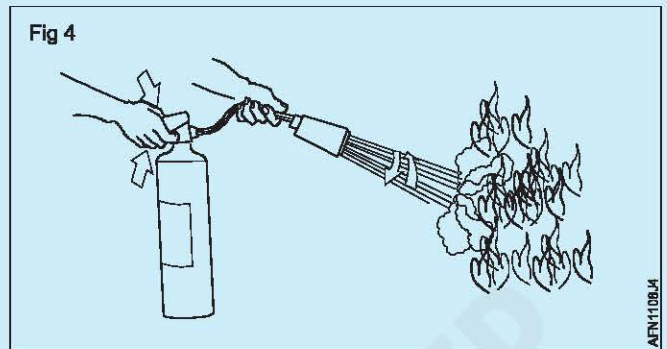

Fire extinguishers are manufactured for use from the distance.

Caution

- While putting off fire, the fire may flare up.
- Do not be panic so long as it put off promptly
- If the fire doesn't respond well after you have used up the fire extinguisher move away your self away from the fire point.
- Do not attempt to put out a fire where it is emitting toxic smoke, leave it to the professionals.
- Remember that your life is more important than property.
- So, don't place yourself or others at risk.

In order to remember the simple operation of fire extinguisher

Remember

P.A.S.S. This will help to use fire extinguisher.

P for pull

A for aim

S for squeeze

S for sweep

Safe use of tools and equipment used in the trade

Objectives: At the end of this exercise you shall be able to

- identify the tools and equipments used in the trade
- record the precaution to be followed while working in fitting jobs.

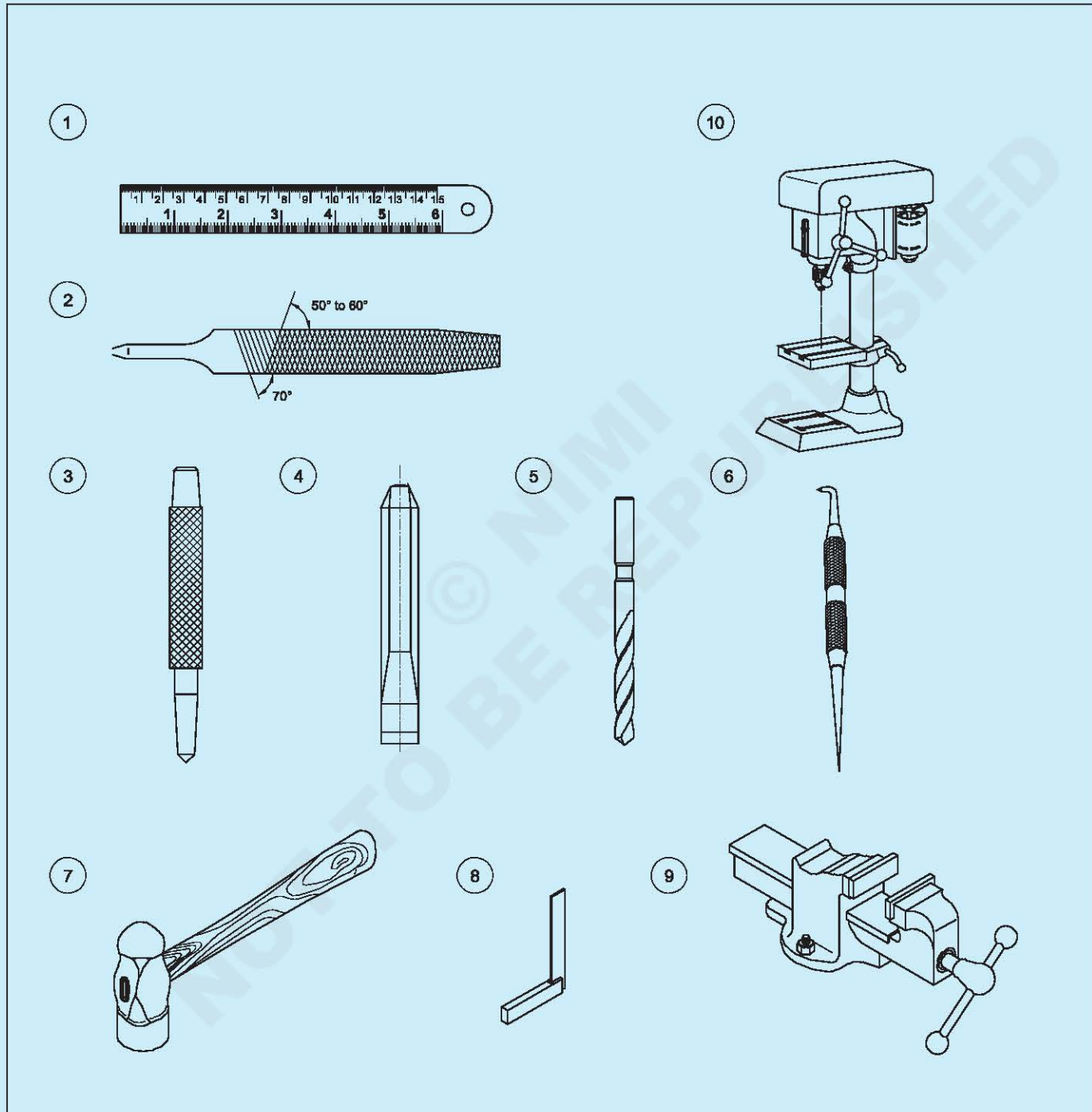

1	-	-	-	-	-	1.1.10
NO.OFF	STOCK SIZE	SEMI-PRODUCT	MATERIAL	PROJECT NO.	PART NO.	EX. NO.
SCALE: NTS	FITTER TOOLS AND EQUIPMENTS				TOLERANCE :	TIME : 1Hr
					CODE NO. AFN1110E1	

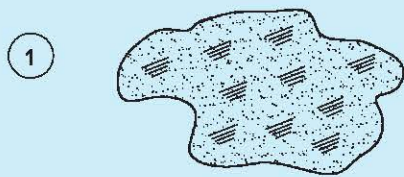

1
OIL SPILLS ON SHOP FLOOR
AND WORK TABLE

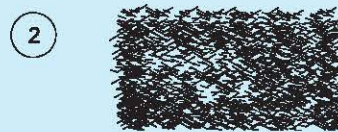

2
METAL CHIPS SPREAD ON SHOP
FLOOR NEAR DRILLING MACHINE

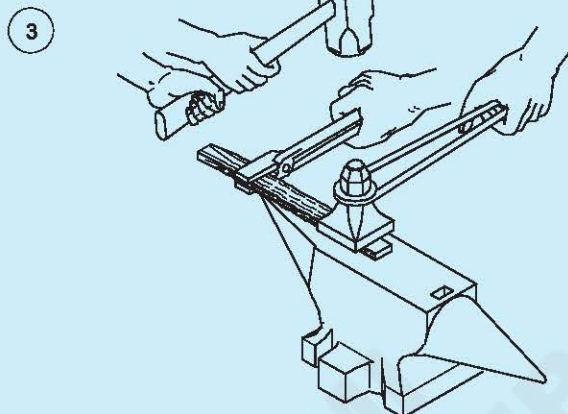

3
HANDLING HOT JOBS WITHOUT GLOVES

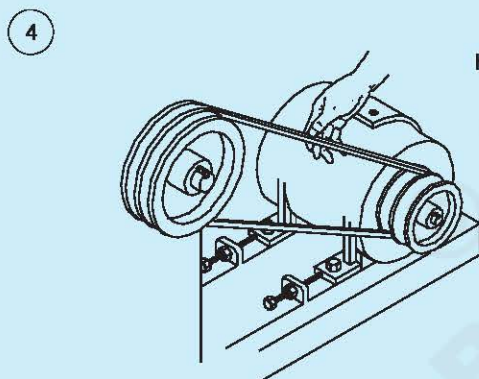

4
MACHINE RUNNING WITHOUT BELT GUARD

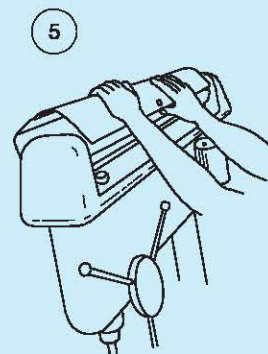

5
CHANGING THE BELT WHEN THE
SPINDLE IS ROTATING

1	-	-	-	-	-	1.1.09
NO.OFF	STOCK SIZE	SEMI-PRODUCT	MATERIAL	PROJECT NO.	PART NO.	EX. NO.
SCALE: NTS	PRECAUTIONS WHILE WORKING IN FITTING JOBS				TOLERANCE :	TIME : 2Hr
					CODE NO. AFN1109E1	

6

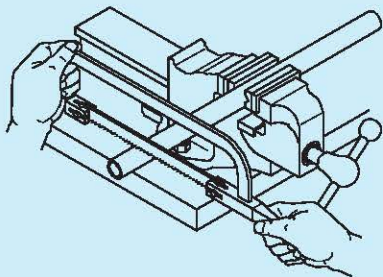

HACKSAWING WITHOUT HANDLE

7

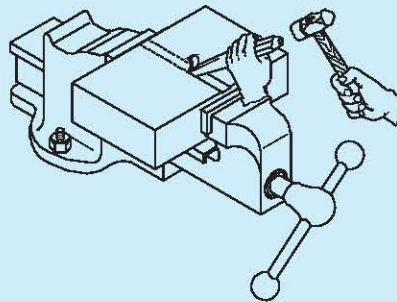

CHIPPING ON METAL WITHOUT CHIPPING SCREEN

8

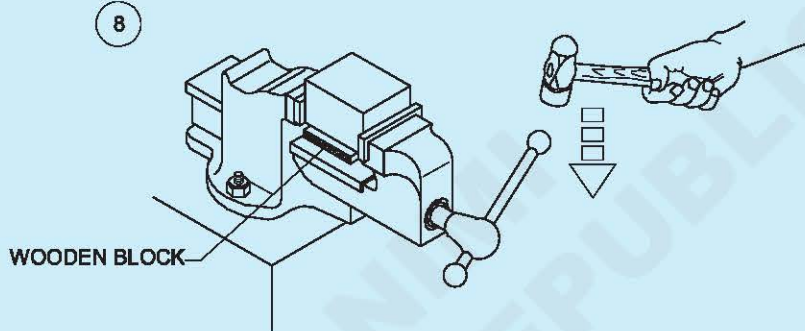

WOODEN BLOCK

STRIKING ON VICE HANDLE WITH HAMMER TO GRIP THE WORK PIECE

9

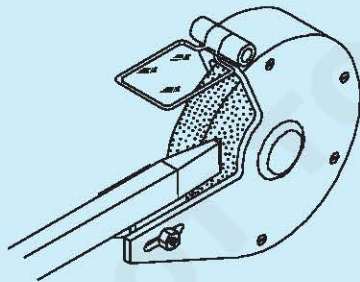

GRINDING A FLAT CHISEL IN SIDE WAYS OF GRINDING WHEEL

10

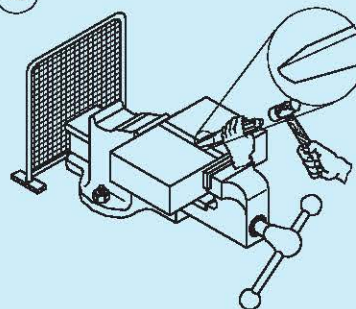

CHIPPING WITH BLUNT CHISEL ON METAL SURFACE

1	-	-	-	-	-	1.1.09
NO.OFF	STOCK SIZE	SEMI-PRODUCT	MATERIAL	PROJECT NO.	PART NO.	EX. NO.
SCALE: NTS	PRECAUTIONS WHILE WORKING IN FITTING JOBS				TOLERANCE :	TIME : 2Hrs
					CODE NO. AFN1109E2	

PROCEDURE

TASK 1: Identification of tools & equipment using in the trade

The instructor shall emphasise the students about to identify the tools and equipment used in trade and guide them to record their names and safety while using.

- 1 Record the name of the tools and equipments in Table 1

Table 1

Fig no	Name of tools/ equipments	Record precautions to be followed while using tools/ equipments
1		
2		
3		
4		
5		
6		
7		
8		
9.		
10		

Fill up and get it checked by your instructor.

TASK 2: Precautions to be followed while working in fitting jobs

The instructor shall guide and demonstrate the students to practice and understand precautions to be followed while working in fitting jobs.

- 1 Record the precautions to be followed while working in fitting job in Table 2

Table 2

S.No.	Description	Record precautions to be followed while working in fitting job
1		
2		
3		
4		
5		
6		
7		
8		
9.		
10		

- Fill up and get it checked by your instructor.

Selection of material as per application

Objectives: At the end of this exercise you shall be able to

- select the material for engineering application
- record it in the table.

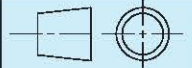

	-	-	-	-	-	1.2.12
NO.OFF	STOCK SIZE	SEMI-PRODUCT	MATERIAL	PROJECT NO.	PART NO.	EX. NO.
SCALE: NTS	SELECTION OF MATERIAL AS PER APPLICATION				TOLERANCE :	TIME : 1Hr
					CODE NO. AFN1210E1	

Job Sequence

- Trainees will determine the type of material used for the purpose mentioned in the table.
- Record it in table 1.

Table 1

S.No.	Part Name	Material used for manufacturing
1	Vernier Caliper	
2	Scriber	
3	Hacksaw blade	
4	Protective coating on Iron and steel	
5	Worm wheels, Gears	
6	Casting of guns	
7	Bell	
8	Machine Bed casting	
9	Die block, hand tools	
10	High speed steel	
11	Bolts and nuts	
12	Surface plate	

- Get it checked by the instructor.

Aeronautical Structure & Equipment Fitter – Basic fitting operations

Foreign object damage (FOD) and tool inventory

Objectives: At the end of this exercise you shall be able to

- identify the FOD
- record the FOD found correctly
- make the tool inventory.

PROCEDURE

TASK 1: Identify and record the FOD

The instructor will present the different types of FODs and the damage they may cause. He shall put five FODs in the toolboxes. He will ask the trainees to look for them and write them down in Table 1.

Trainees will:

- 1 Note down the FODs found in the tool box
- 2 Record them in Table 1.

The instructor will check for correctness.

Table 1

SI.No	FOD found	Origin / How to avoid
1		
2		
3		
4		
5		

Fill up and get it checked by your instructor.

TASK 2: Practice on make the inventory sheet

The instructor will brief trainees on the different tools used and suggest how to arrange them in the toolbox. He will provide the trainees with the inventory sheet and explain how to complete it.

Trainees will:

- 1 Make the inventory and put away the tools.
- 2 Complete the inventory sheet.

The instructor will check the inventory sheet and arrangement of the tools

Marking out lines, gripping suitably in vice jaws, and hacksawing to given dimensions

Objectives: At the end of this exercise you shall be able to

- mark out lines using a jenny calliper
- hold the workpiece in a bench vice
- cut along marked lines.

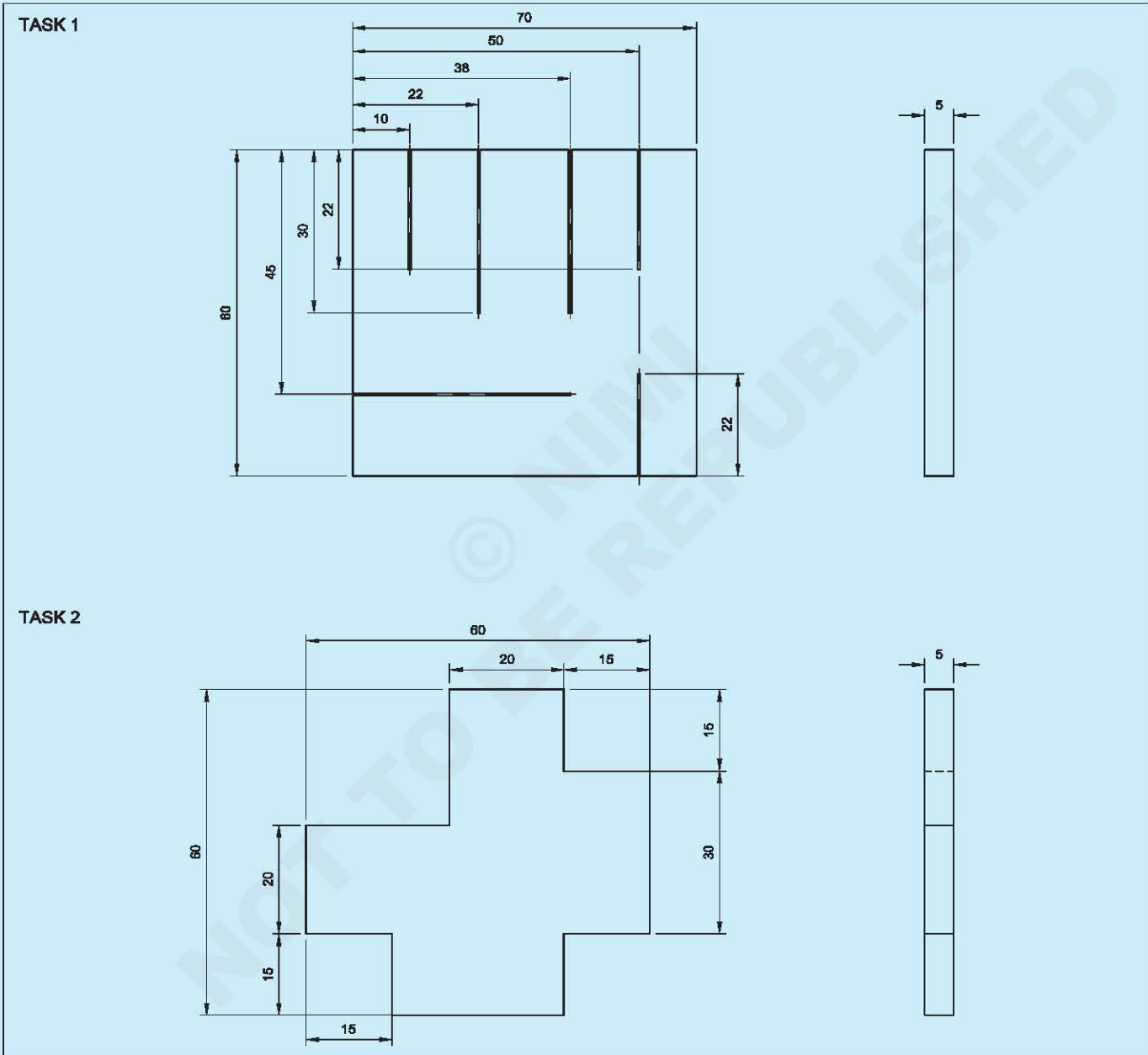

1	60 X60X5	-	FE310 PRE-MECHINED	-	TASK-2	1.2.12
1	60X60X5	-	A2017 PRE-MACHINED	-	TASK-1	1.2.12
NO.OFF	STOCK SIZE	SEMI-PRODUCT	MATERIAL	PROJECT NO.	PART NO.	EX. NO.
SCALE	MARKING AND SAWING				DEVIATIONS	TIME: 10HOURS
					CODE NO. AFN1212E1	

PROCEDURE

TASK 1: Marking and hacksawing steel

- 1 Check the dimensions of the pre-machined workpiece using a steel rule: 60x60x5 mm
- 2 Place the workpiece in the surface plate.
- 3 Set the jenny calliper to 10 mm using the steel rule.
- 4 Draw a 10-mm-long line parallel to the "AB" side with the jenny calliper as shown in Fig 1.
- 5 Similarly, set the jenny calliper to 22 mm, 38 mm and 50 mm and draw lines parallel to "AB" (Fig 1).

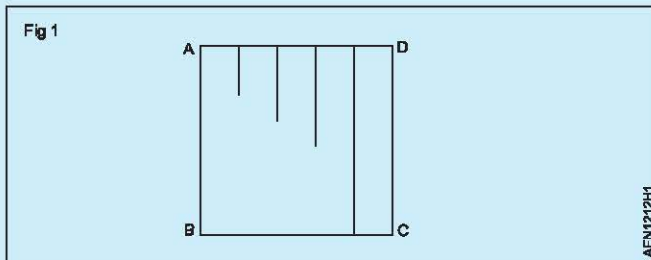

- 6 Set the jenny calliper to 22 mm using a steel rule.
- 7 Draw a line parallel to the "AD" side using the jenny calliper.
- 8 Similarly, set the jenny calliper to 30 mm and 45 mm and draw lines parallel to the "AD" side as shown in Fig 2.

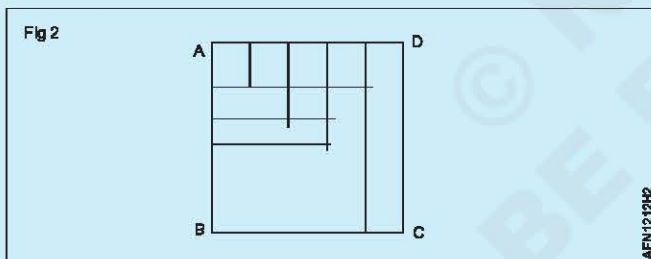

- 9 Set the jenny calliper to 22 mm using a steel rule.
- 10 Draw a line parallel to the "BC" side using the jenny calliper as shown in Fig 3.

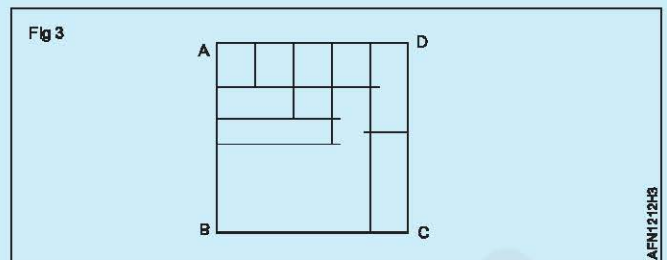

- 11 Hold the workpiece firmly in the bench vice, keeping the "AD" side parallel to the vice Jaws.
- 12 Select a 1-mm pitch hacksaw blade, fix the blade in the hacksaw frame, with the teeth pointing forward.
- 13 Tighten the blade to the required tension with the wing nut.
- 14 File a notch at the point in which the hacksaw is placed to avoid slippage of the blade.
- 15 Start cutting with a slight downward pressure using the hacksaw.
- 16 Saw along the lines.
- 17 Apply pressure in the forward stroke.
- 18 Release the pressure in the return stroke.
- 19 Use the full length of the blade while sawing.
- 20 Check the size with a steel rule.

TASK 2: Marking and hacksaw cutting

- 1 Check the dimensions of the pre-machined workpiece using a steel rule: 60x60x5 mm.
- 2 Place the workpiece on the surface plate.
- 3 Set the jenny calliper to 15 mm using a steel rule.
- 4 Draw a 15-mm-long line parallel to the "AB" side using the jenny calliper (Fig 4).
- 5 Repeat the previous steps and draw 15-mm lines parallel to "BC", "CD", and "AD" As shown in Fig 4.
- 6 Set the jenny calliper to 35 mm (15+20) using a steel rule.
- 7 Draw a 35-mm line parallel to the "BC" and "CD" sides using the jenny calliper as shown in Fig 5.
- 8 Hold the workpiece firmly in the bench vice, keeping the "AD" side parallel to the vice jaws.

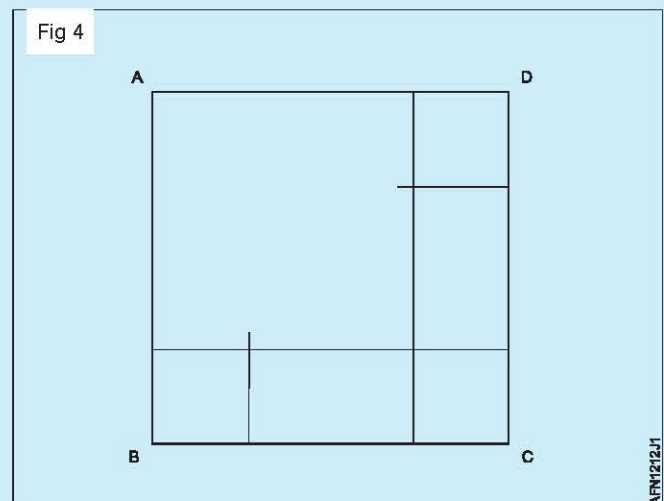

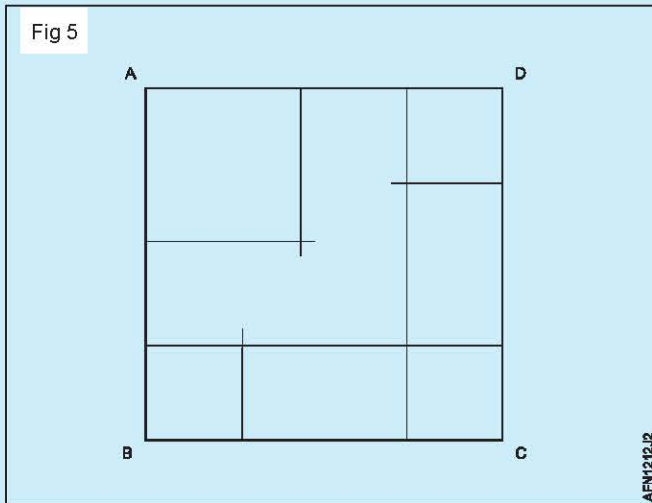

9 Start cutting on the “AD”, cut the line from point 1 to 2, keeping the hacksaw on the right side of the line (Fig 6).

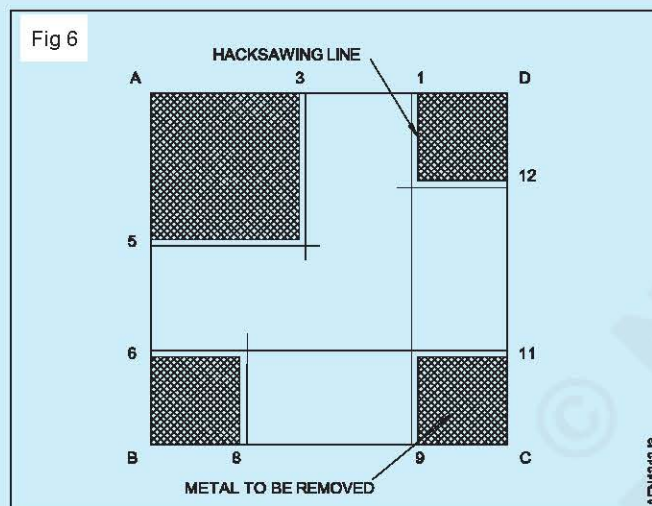

Cut close to the line. Ensure that the line is visible while sawing.

- 10 Without changing the position of the workpiece cut the line from point 3 to point 4, keeping the hacksaw on the left side of the line.
- 11 Similarly, turn the workpiece and cut the line from 5 to 4, 6 to 7, 8 to 7, 9 to 10, 11 to 10 and 12 to 2.
- 12 After sawing the workpiece (Fig 7), check the size with a steel rule.

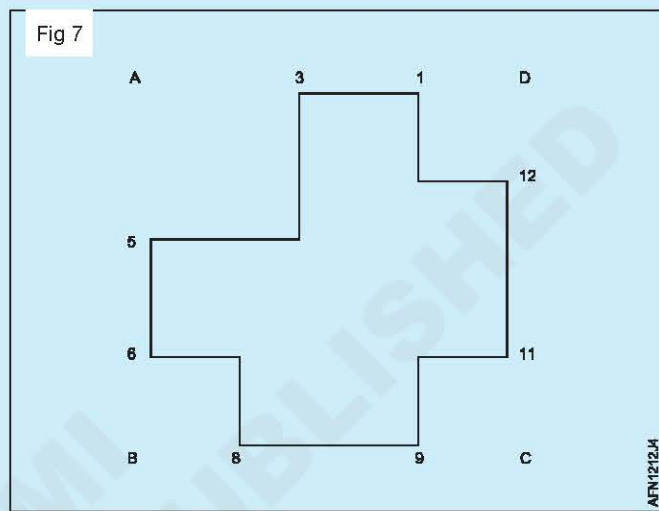

Skill sequence

Measuring with a steel rule

Objective: This shall help you to
 • **measure lengths.**

Place the rule either directly on to the length to be measured or at a right angle to the reference plane.

Use a straight contact face if possible (engineer’s square, surface block, Vee block, etc.) and read off measurements by looking at the steel rule directly. (Fig 1)

You can also measure with a rule starting off from the centimetre line (Fig 2).

For correct measurements hold the rule parallel to the edge of the workpiece (Fig 3).

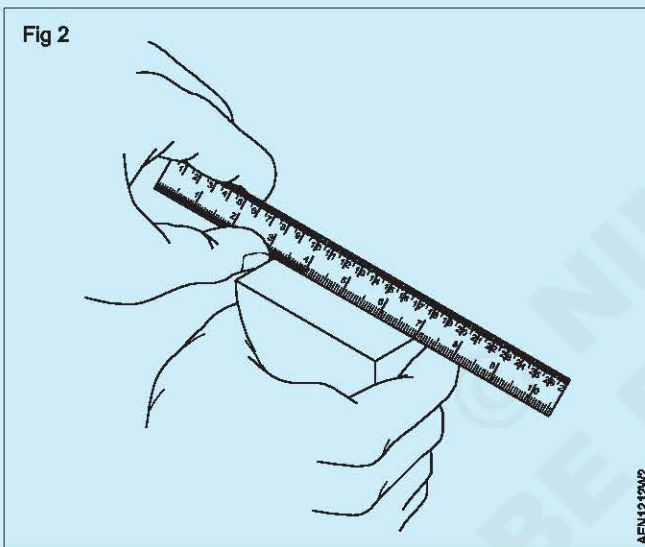
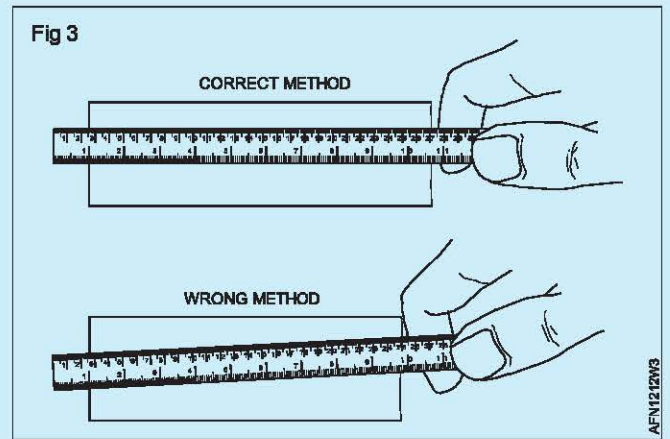
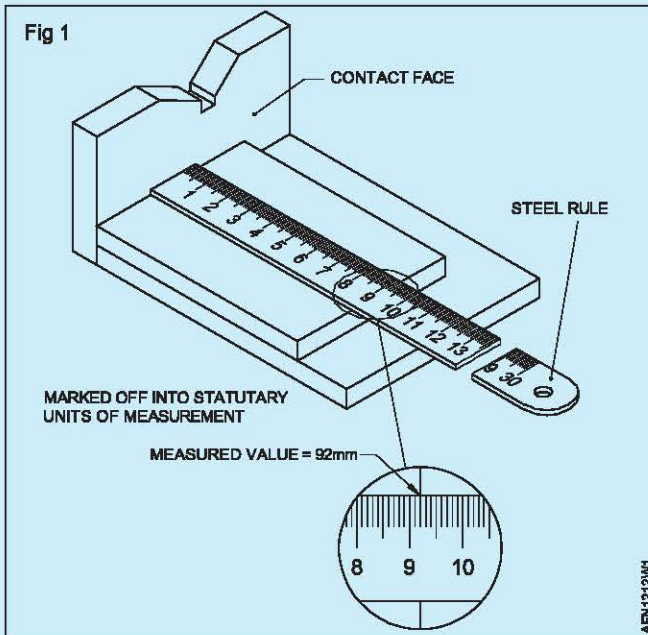

Marking lines parallel to the edge with a jenny calliper

Objective: This shall help you to

- mark parallel lines using a jenny calliper.

Apply marking medium on the surface to be marked.

Set the jenny calliper to the size to be marked (i.e. dimension) with a steel rule (Fig 1).

Transfer the set dimension to the workpiece. (Fig 2)

Incline slightly and move the jenny calliper with uniform speed and mark lines.

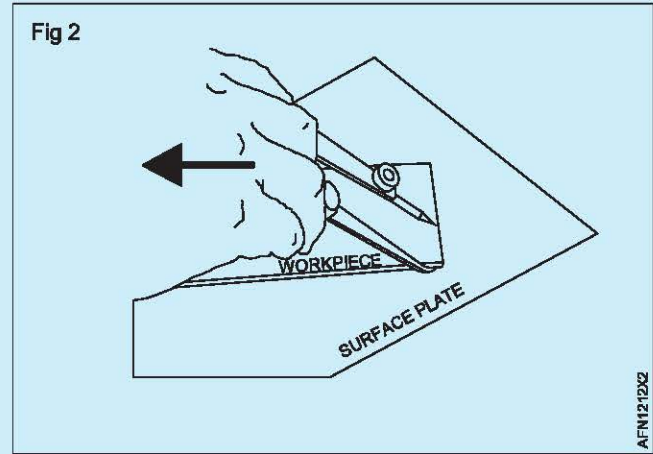
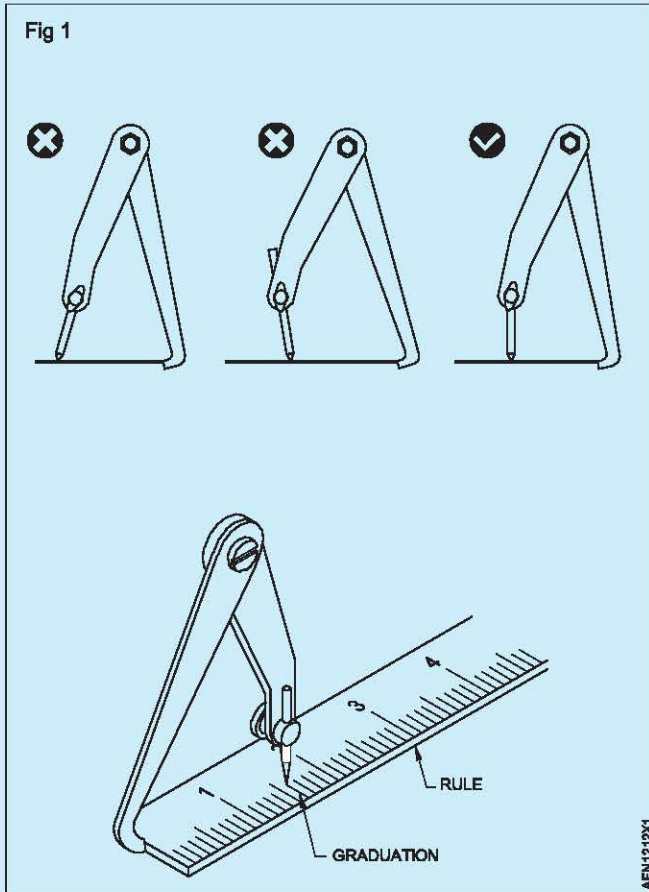

Clamping the workpiece in the bench vice to sawing

Objective: This shall help you to

- clamp a workpiece firmly in a bench vice
- clamp a workpiece without damaging the edges and surfaces.

A bench vice is used to clamp the workpiece in the required position to perform different operations such as cutting, filing, etc.

- Check the height of the bench vice. For ease in working, the recommended height of the bench vice is shown in Fig 1.

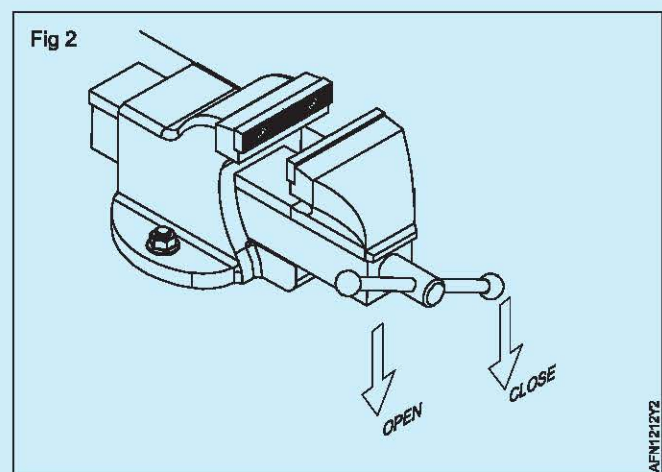
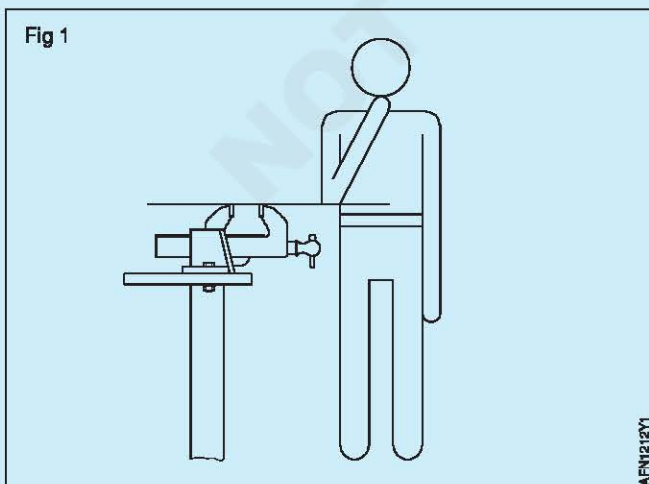

- Use soft metal like aluminium angle (B) to protect the surface of the workpiece from damage by the hard jaws (A) (Fig 3).

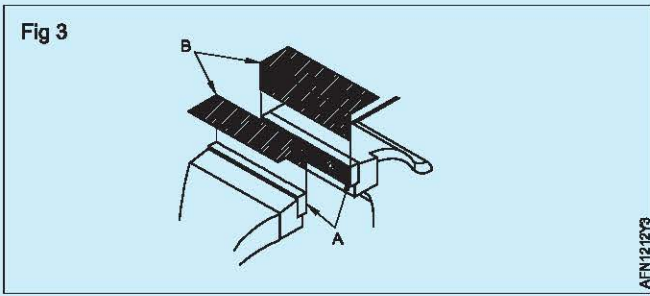

- Set the correct position of the workpiece. Hold the workpiece in the bench vice with a minimum projection from the top of the vice jaw without touching the vice.
- Close the jaws of the bench vice to tighten the workpiece lightly by turning the handle in clockwise direction.

Sawing along a line

Objective: This shall help you to

- **cut along a straight line by hacksaw.**

Clamp the workpiece on the vice and make sure that the marked sawing line is close to the side of the vice jaws to achieve maximum firmness.

Tighten the jaws firmly to avoid tilting and shifting of the workpiece.

If the section being cut shows chattering effect or vibration, the clamping needs to be improved.

Select the correct pitch blade for cutting.

The shorter the cutting section is, the finer the blade pitch that needs to be used. Make sure that at least 3 teeth are cutting at a time.

The harder the material the finer the blade pitch should be.

Fix the blade so that the teeth are in the direction of the cut.

Tighten and tension the blade by hand using only the wing nut.

Caution

Insufficient blade tension > the cut will not be straight.

Too much tension > the blade will break.

Make a notch at the starting point on a smooth and hard material to prevent the hacksaw from slipping (Fig 1).

Hold the hacksaw properly at an angle of 5 to 30° (Fig 2).

Apply a little downward hand force so that only a few teeth are cutting. Press down only during the forward (cutting) stroke.

Use the full length of the blade to avoid early dulling of the teeth in the middle portion of the blade.

Move the blade strictly in line with the marked direction.

Do not tilt the frame while sawing because bending of the blade can cause sudden breakage of the blade.

Resort to cutting from the opposite side if the deviation from the marked line is excessive.

Slow down the cutting while completing the cut to avoid breakage of the blade and injury to yourself

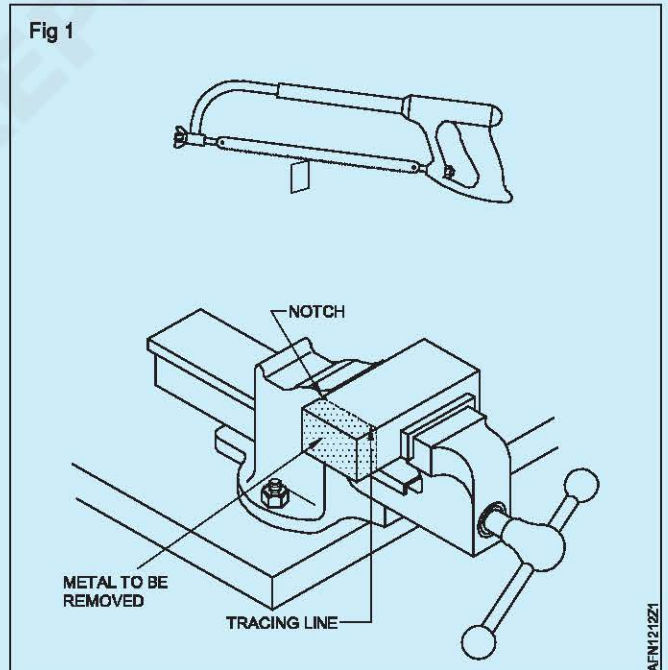

Sawing different types of metals of different sections

Objectives: At the end of this exercise you shall be able to

- cut metals of different thicknesses
- cut sections of metals.

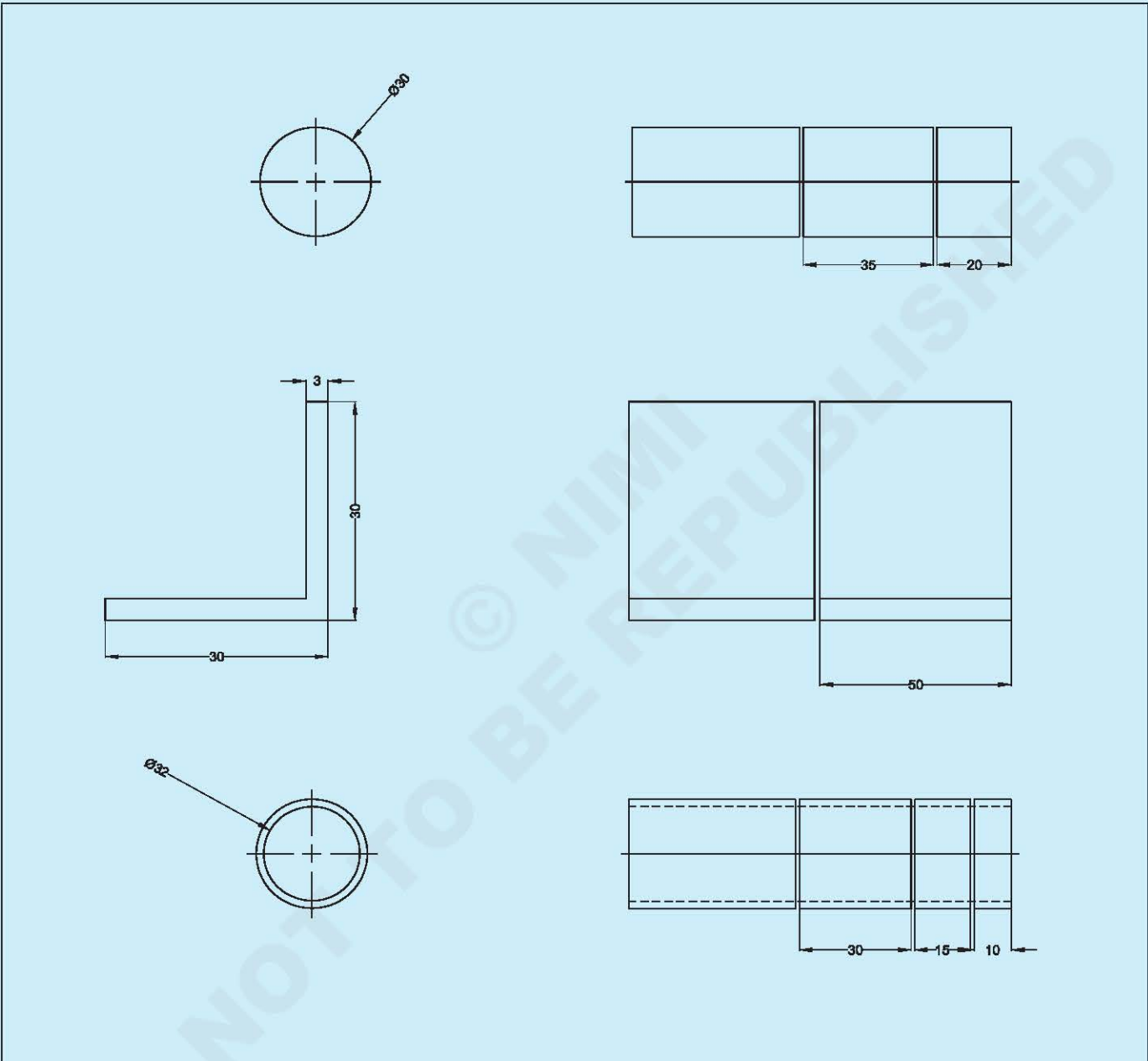

1	Ø 32 – 100 mm	-	Fe310	-	TASK 3	1.2.13
1	30 x 30 x 3 – 100 mm	-	2017	-	TASK-2	1.2.13
1	Ø 30 – 100 mm	-	Fe310	-	TASK-2	1.2.13
NO.OFF	STOCK SIZE	SEMI-PRODUCT	MATERIAL	PROJECT NO.	PART NO.	EX. NO.

SCALE	HACKSAWING IN DIFFERENT TYPES OF METALS	DEVIATIONS	TIME: 5HOURS
		CODE NO: AFN1213E1	

PROCEDURE

TASK 1: **Sawing on steel round bar (rod)**

- 1 Check the dimensions of the raw material using a steel rule: $\text{Ø}30 \times 100 \text{ mm}$
- 2 Apply marking media only where marking is required.
- 3 Place the round rod on the levelling plate.
- 4 Use a 'V' Block to support the round rod while marking it with a surface gauge.
- 5 Hold the workpiece in the bench vice.
- 6 Fix a 1.8-mm pitch hacksaw blade in a hacksaw frame.
- 7 File a notch at the point where the hacksaw is placed to prevent the blade from slipping.
- 8 Start cutting the round rod using the hacksaw while applying a slight downward pressure.
- 9 Cut on the hacksawing line while applying the proper pressure on the forward and return strokes. Use the full length of the blade.
- 10 The cutting movement should be steady while sawing the round rod.
- 11 While finishing the cut, slow down the pressure to avoid breakage of the blade and injury to yourself and others.
- 12 Check the size of the round rod with a steel rule.

Selection of hacksaw blade

For soft materials use a 1.8-mm pitch blade for sawing.

For hard materials use a 1.4-mm pitch blade for sawing.

TASK 2: **Sawing on aluminium angle**

- 1 Check the dimensions of the raw material using a steel rule: aluminium angle $30 \times 30 \times 3 - 100 \text{ mm}$.
- 2 Mark the sawing lines.
- 3 Hold the workpiece in the bench vice as shown in Figure.1
- 4 Fix a 1.8-mm coarse pitch blade in the hacksaw frame.
- 5 Cut along the sawing lines with the hacksaw.
- 6 Check the size of the angles with a steel rule.

Caution

Select the correct pitch blade according to the shape and materials to be cut.

While sawing, three or more teeth of the blade should be in contact with the metal section.

TASK 3: **Sawing on steel pipe**

- 1 Check the dimensions of the raw material using a steel rule: steel pipe to size $\text{Ø}32 \times 100 \text{ mm}$.
- 2 Mark the sawing lines.
- 3 Hold the workpiece in the bench vice as shown in Fig 1.
- 4 Fix the 1.0-mm pitch blade in the hacksaw frame
- 5 Cut along the sawing lines with the hacksaw.
- 6 Turn and change the position of the pipe while hack sawing.
- 7 Check the size of the pipe with a steel rule.

Caution

Avoid over tightening the pipe in the vice which cause deformation.

Do not cut too fast.

Cut slowly and reduce pressure while cutting through.

Skill sequence

Marking in a cylindrical part

Objective: This shall help you to

- mark in cylindrical parts using a Vee block and a surface gauge.

Hold the workpiece on the Vee block.

Set the surface gauge to the size to be marked (i.e. dimension) with a steel rule.

You can also mark the dimension on the workpiece and set the surface gauge to this mark.

Transfer the set dimension to the workpiece by moving the surface gauge around the part or by rotating the workpiece (Fig 1).

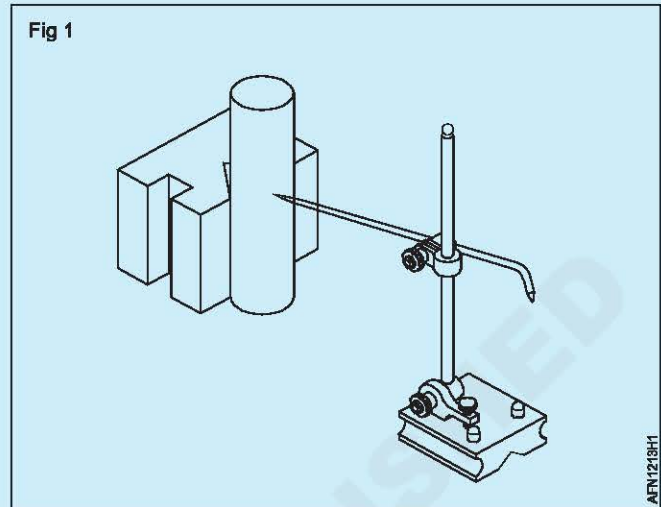

Marking in an angle

Objective: This shall help you to

- mark in an angle using an engineer's square.

Mark the dimension with a steel rule.

Position the square on the angle (Fig 1).

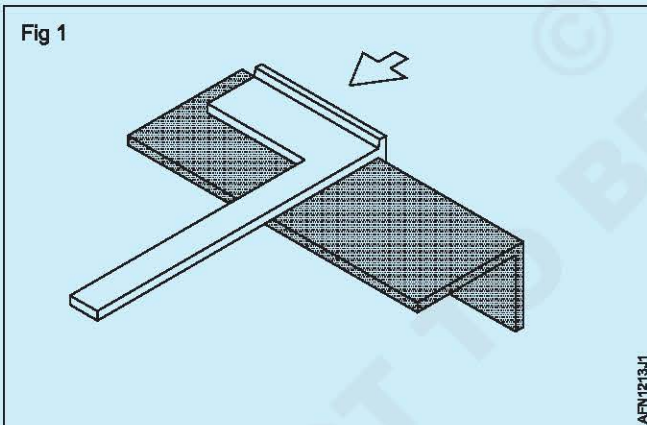

Trace the line.

Position the square on the other flange of the angle in alignment with the line.

Trace the line (Fig 2).

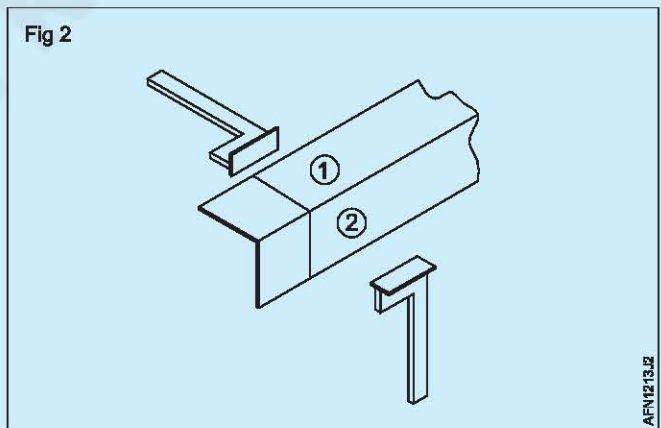

Hacksawing (holding-pitch selection)

Objective: This shall help you to

- cut along a straight line in a different shape by hacksaw.

Depending on the shape of the workpiece to be cut, holding it in position in the vice is important.

The cutting angle will also be chosen according to the shape.

Choose the blade pitch and the cutting angle so that there are always at least 3 teeth in contact with the workpiece.

Position the workpiece in the vice with the marked line as close as possible to the jaws.

Make a notch at the starting point to prevent the hacksaw from slipping.

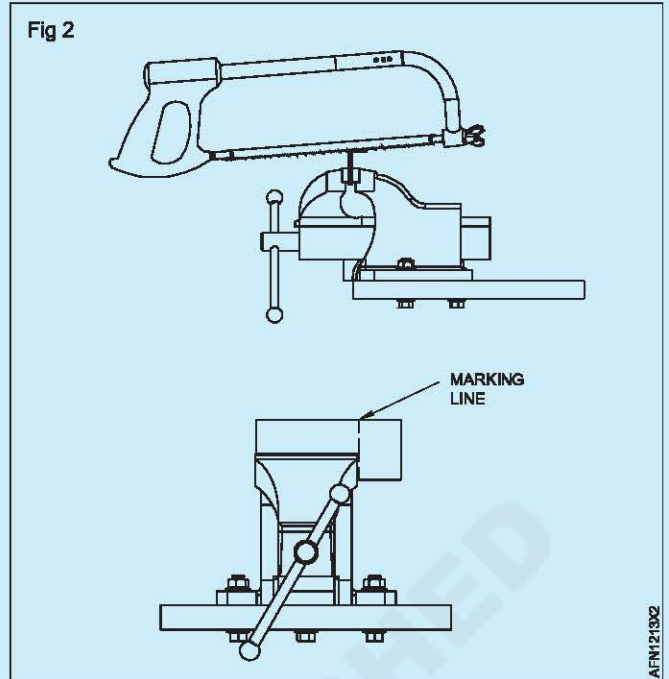
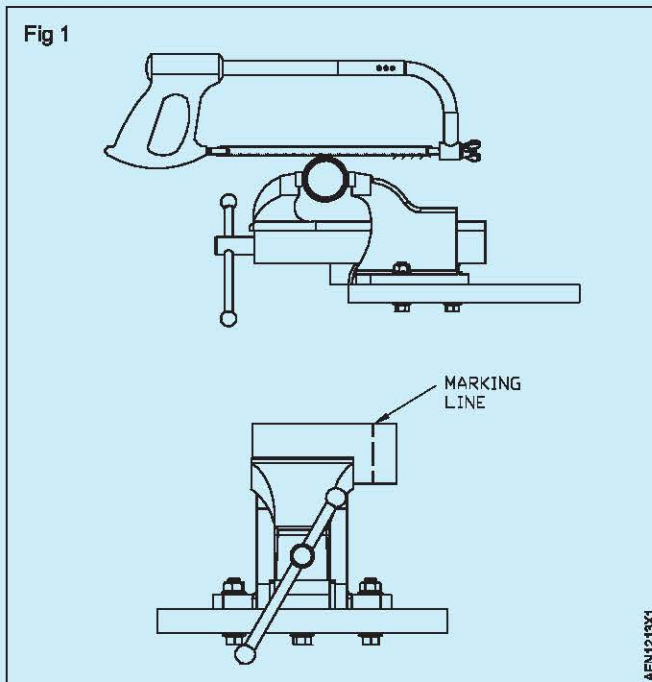

Slow down the cutting while completing the cut to avoid breakage of the blade and injury to yourself.

Sawing and filing thin aluminium sheet metal

Objectives: At the end of this exercise you shall be able to

- mark out lines using a jenny calliper
- cut along marked lines
- file thin sheet metal to give dimension.

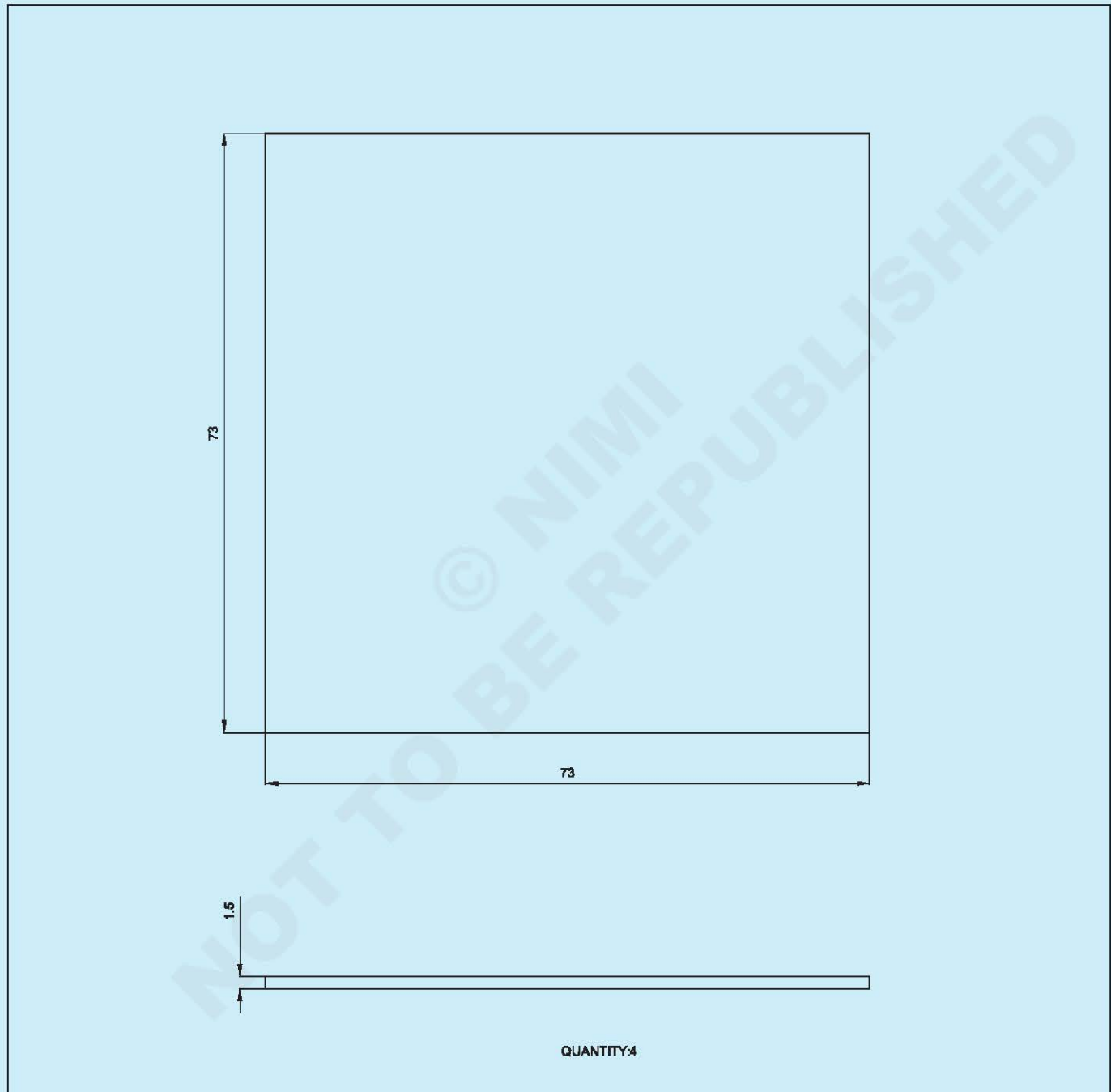

QUANTITY:4

2	150 x 150 x 1.5	-	A2024	-	TASK-1 & 2	1.2.14
NO.OFF	STOCK SIZE	SEMI-PRODUCT	MATERIAL	PROJECT NO.	PART NO.	EX. NO.
SCALE		MARKING AND SAWING			DEVIATIONS	TIME: 5HOURS
					CODE NO: AFN1214E1	

PROCEDURE

TASK 1: Marking and hacksawing

- 1 Check the dimensions 150x150x1.5 mm
- 2 File the four surfaces "AB", "BC", "CD" and "DA" by draw filing.
- 3 Check flatness and deburr edges.
- 4 Place the workpiece in the surface plate.
- 5 Set the jenny calliper to 73 mm using the steel rule.
- 6 Draw a 73-mm-long line parallel to the "AB", "BC", "CD" and "DA" side with the jenny calliper as shown in Fig 1.

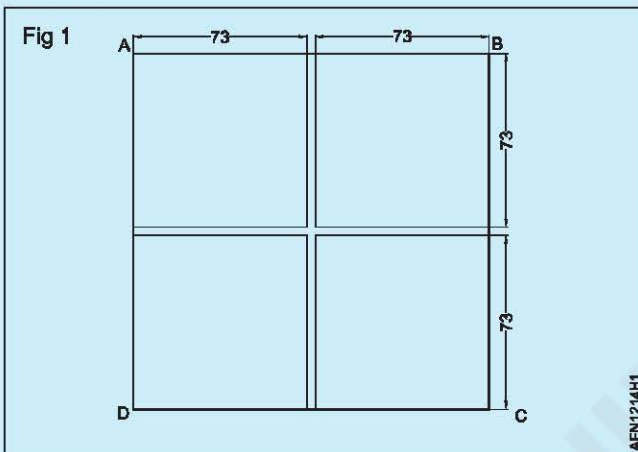

- 7 Hold the workpiece firmly in the bench vice between two pieces of wood (Fig 2).
- 8 Select a 1-mm pitch hacksaw blade, fix the blade in the hacksaw frame, with the teeth pointing forward.

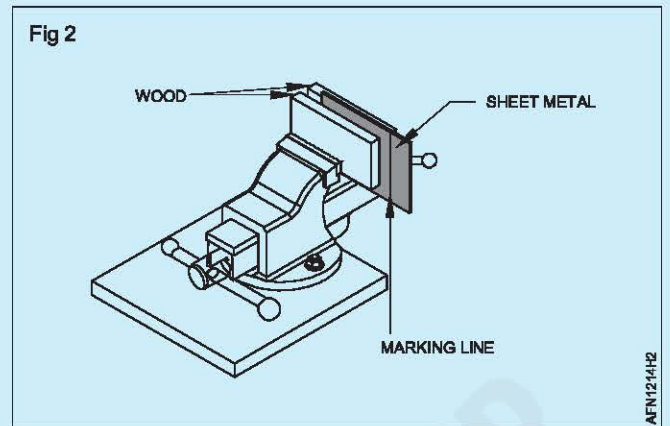

- 9 Tighten the blade to the required tension with the wing nut.
- 10 File a notch at the point in which the hacksaw is placed to avoid slippage of the blade.
- 11 Start cutting with a slight downward pressure using the hacksaw.
- 12 Saw between the lines.
- 13 Apply pressure in the forward stroke.
- 14 Release the pressure in the return stroke.
- 15 Use the full length of the blade while sawing.
- 16 Check the size with a steel rule.

TASK 2: Filing thin workpiece

- 1 Set the workpiece in the bench vice.
- 2 File side 1 and 2 parallel and square with others.
- 3 Check flatness, squareness and deburr edges.
- 4 Check the dimension with steel rule. (Fig 3)

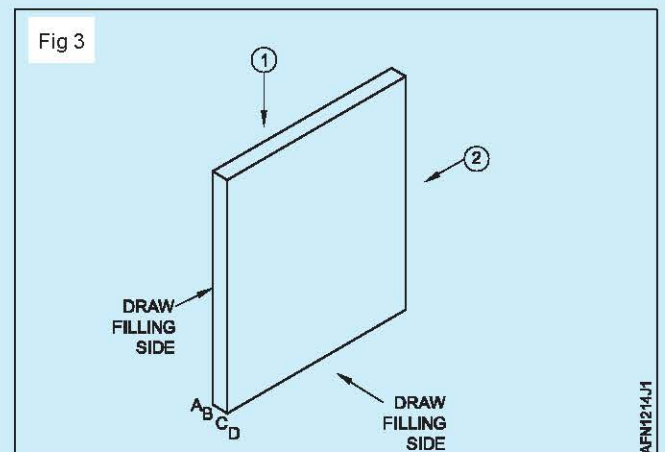

Skill sequence

Filing a thin surface using rasp

Objective: This shall help you to

- file surfaces flat using a rasp.

Hold the handle of the file (Fig 1).

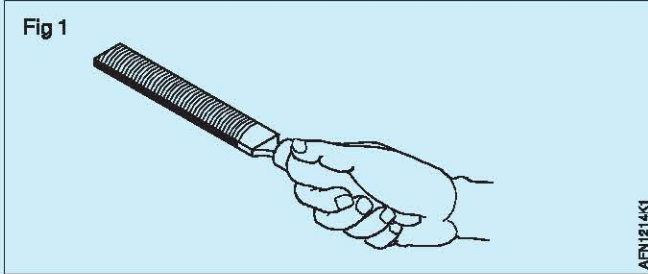

The right hand holds the handle while the left hand holds and orients the rasp by its tip.

Put the rasp on the edge to adjust with angle 15° to 20° (Fig 2).

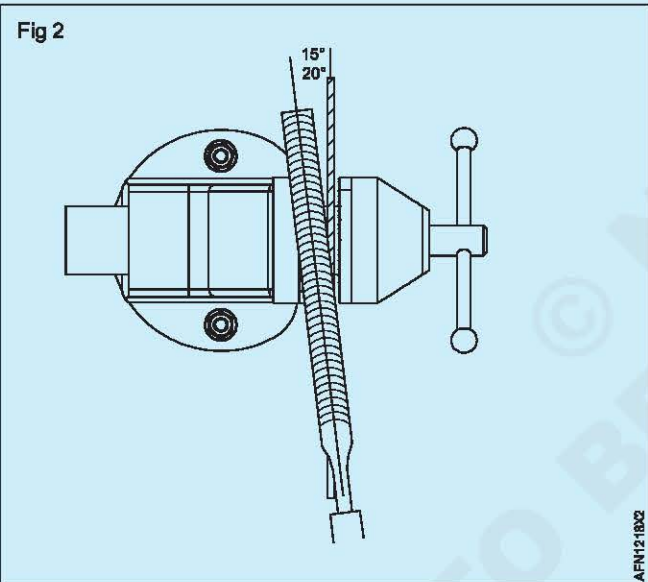

Start filing by pushing the rasp uniformly during the forward stroke and release the pressure during the return stroke.

The rasp slides along the edge as shown in Fig 3.

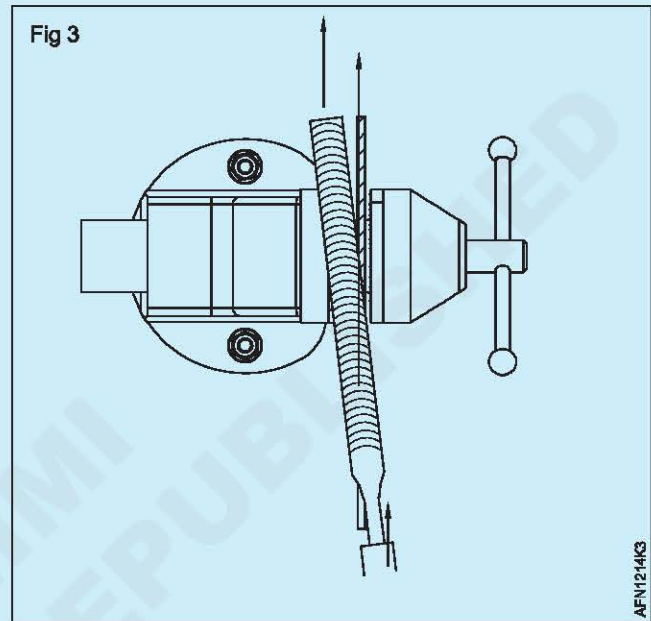

Release the pressure on the rasp at the end of the part.

Checking a flatness of the edge

Objective: This shall help you to

- check the flatness of the edge.

During filing, the surface can be visually observed to a reasonable degree of perfection.

To ensure perfection, the surface should be checked with a beveled straight edge.

Note: the blade of a square can serve as a straight edge.

Burrs should be removed before any checking.

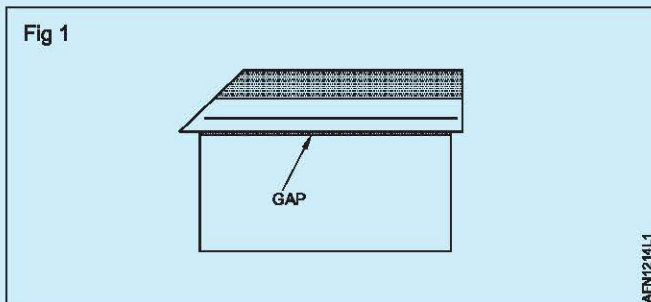

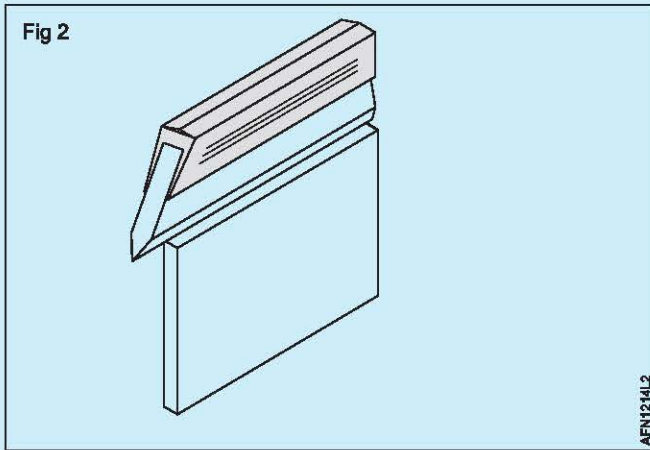

Deburring the sharp edge

Objective: This shall help you to

- deburr edges in thin metal sheet.

The filling process produces burrs.

In order to avoid cuts and incorrect measurements, burrs must be removed.

Preferably use a deburring tool that can be used by pulling. Be careful not to scratch the part with the other parts of the tool. (Fig 1)

Deburring is only performed to remove the formed burr, not to make a chamfer.

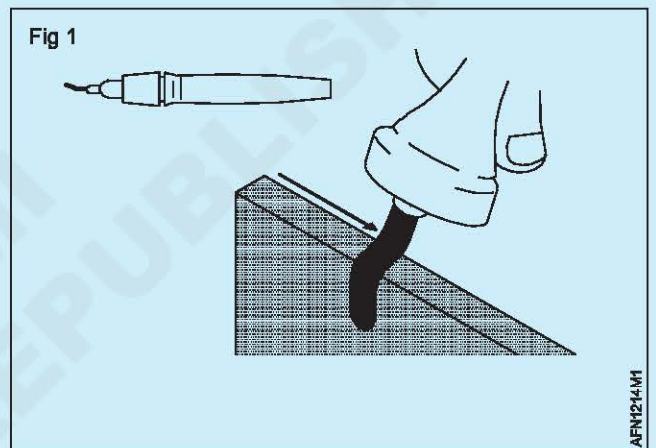

Make sheet metal with flanged holes

Objectives: At the end of this exercise you shall be able to

- file notches in thin sheet metal
- prepare and make flanged holes.

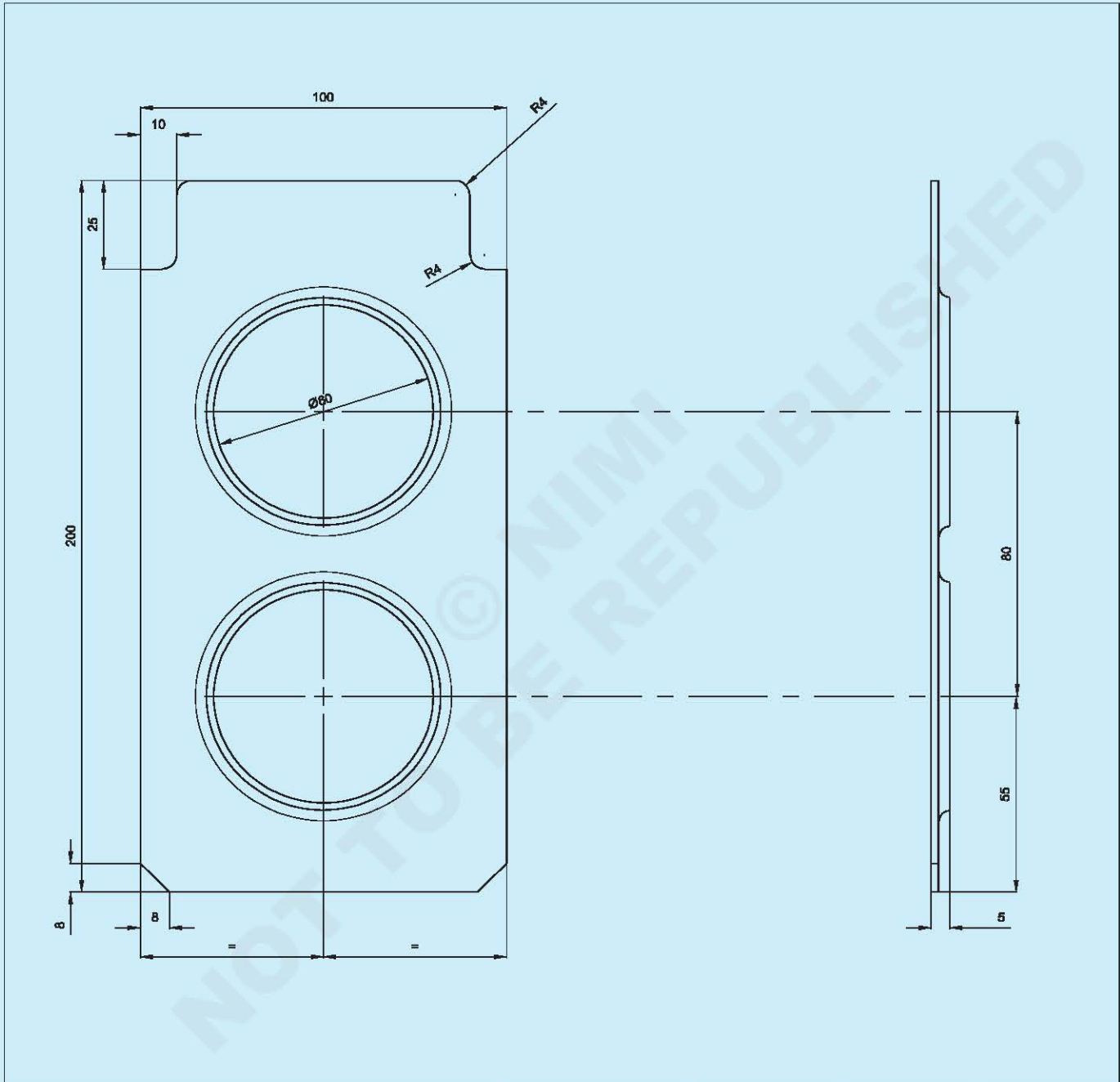

1	100x200x2	--	A2024	--	TASK-1	1.2.15
NO.OFF	STOCK SIZE	SEMI-PRODUCT	MATERIAL	PROJECT NO.	PART NO.	EX. NO.
SCALE	MAKE SHEET METAL WITH FLANGED HOLES				DEVIATIONS	TIME: 15Hrs
					CODE NO: AFN1215E1	

Job Sequence

- 1 Check the raw material with steel rule.
- 2 File the four surfaces to give dimension to an accuracy of ± 0.2 mm.
- 3 Finishing by draw filing.
- 4 Deburr and check.

Chamfers

- 5 Mark the chamfers and file them. (Fig 1)

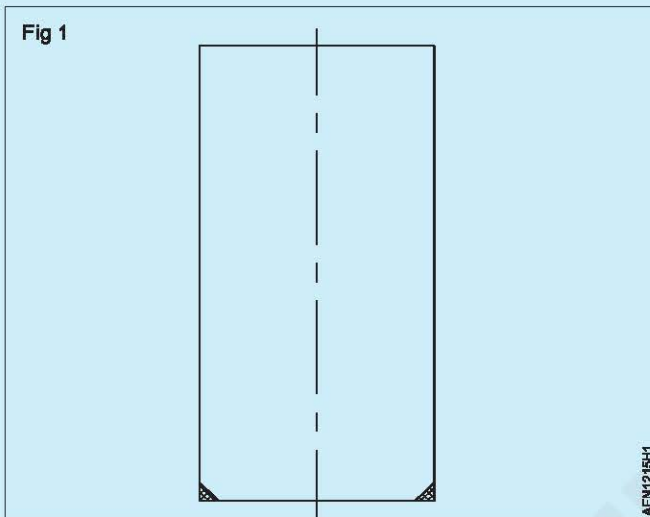

- 6 Finish by draw filing and deburr.
- 7 Check dimension and angle.

Notches

- 8 Mark the notches and the centre of the internal radii. (Fig 2)

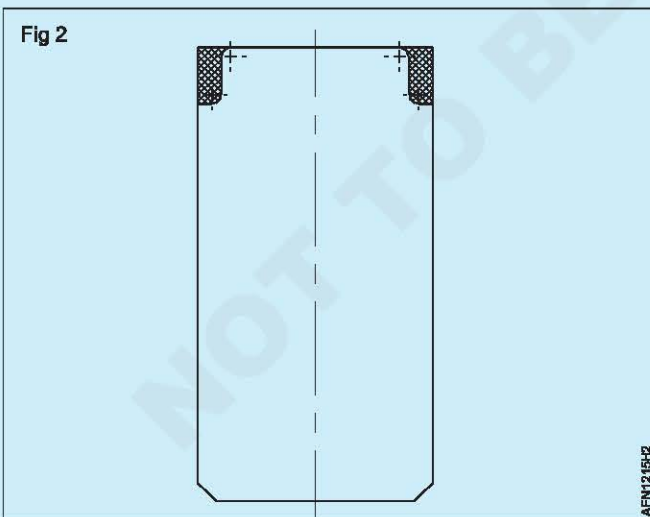

- 9 Mark the external radii.
- 10 Punch and drill to make the internal radii.
- 11 Saw along the marking line.
- 12 File the notches.
- 13 File the external radii.
- 14 Finish by draw filing and deburr.

Flanged holes

- 15 Make the centre of the flanged holes.
- 16 Drill the centre and make lightening flanged holes with press.
- 17 File and deburr the lightening flanged holes.
- 18 Check dimensions.

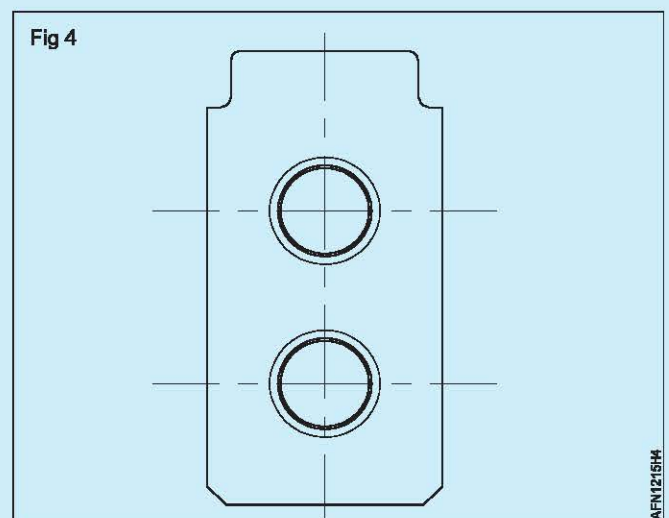
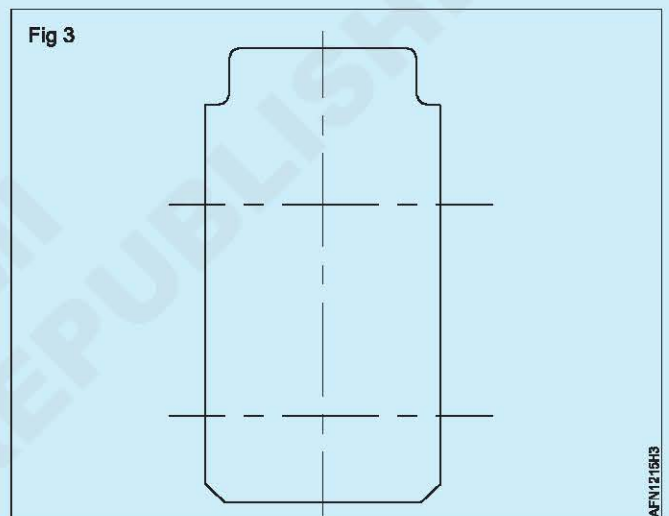

Filing flat, square and parallel to an accuracy of +/-0.5mm

Objectives: At the end of this exercise you shall be able to

- file flat, square and parallel with straight file or rasp
- tracing with surface gauge
- check dimension with vernier calliper. Check dimension with vernier calliper.

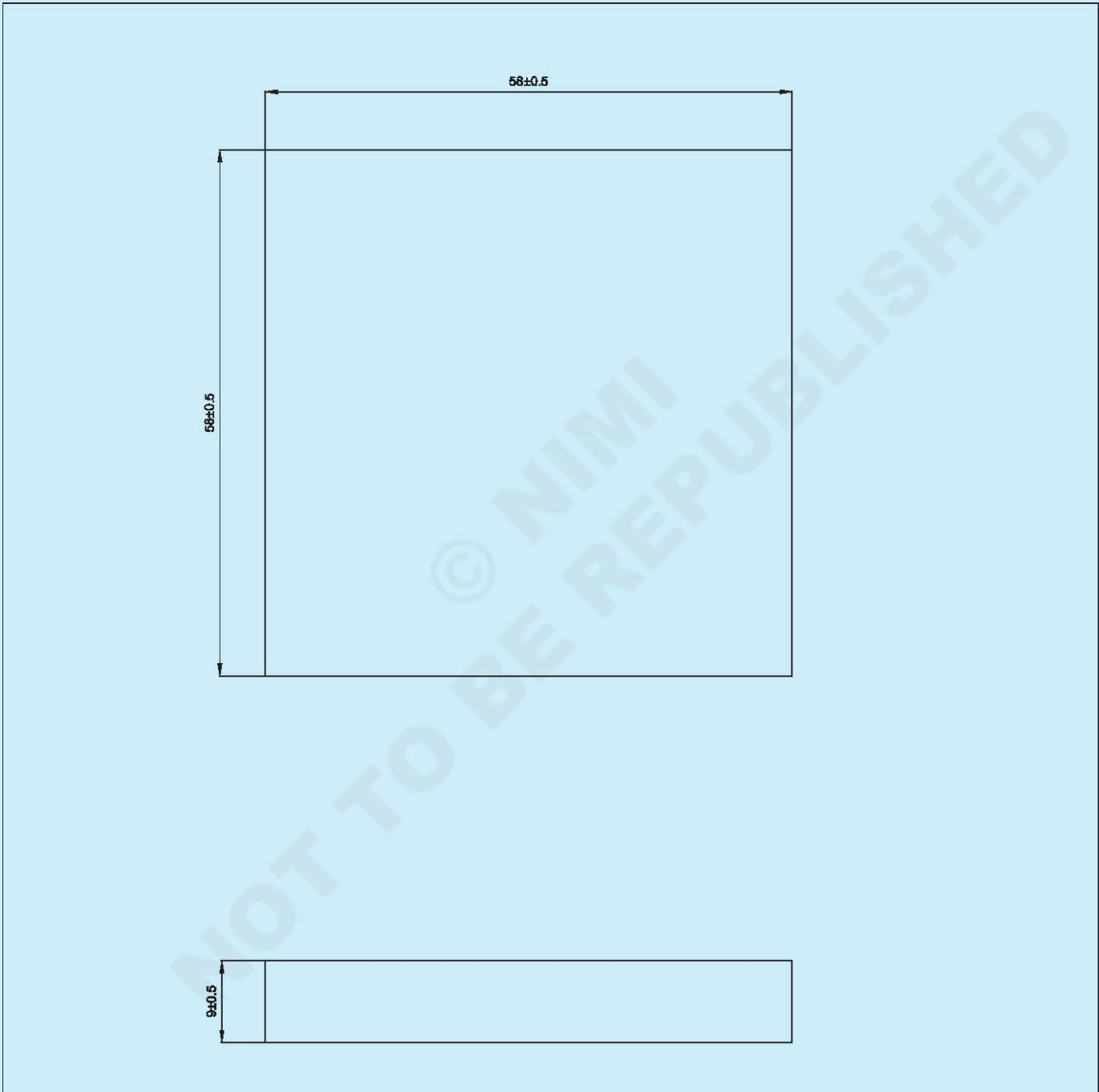

2	60 x 60 x 10	--	A2017	--	TASK-1	1.2.16A
NO.OFF	STOCK SIZE	SEMI-PRODUCT	MATERIAL	PROJECT NO.	PART NO.	EX. NO.
SCALE	FILING FLAT, SQUARE AND PARALLEL WITH AN ACCURACY OF +/-0.5				DEVIATIONS	TIME: 5HOURS
					CODE NO: AFN1216E1	

Job Sequence

- Check the raw material size using steel rule.

File references - Fig 1

- File flat and straight the surface 'A'.
- File surface 'B' perpendicular to 'A'.
- Check flatness and squareness.
- Deburr edges.

File dimensions - Fig 2

- Mark surface 'C' and 'D' to size 58x58mm using surface gauge or vernier height gauge.
- File side 'C' and 'D' by maintaining the size $\pm 0.5\text{mm}$.
- Check size with vernier calliper.
- Check flatness and squareness.
- Finish the four surfaces by draw filing.
- Deburr edges.

File dimensions - Fig 3

- File flat the surface 'E'.
- Finish by cross filing.
- Check flatness.
- Mark sides to size 8mm.
- File opposite side to 'E' by maintaining the size $\pm 0.5\text{mm}$.
- Finish by cross filing.
- Deburr edges.
- Check size with vernier calliper.
- Check flatness.

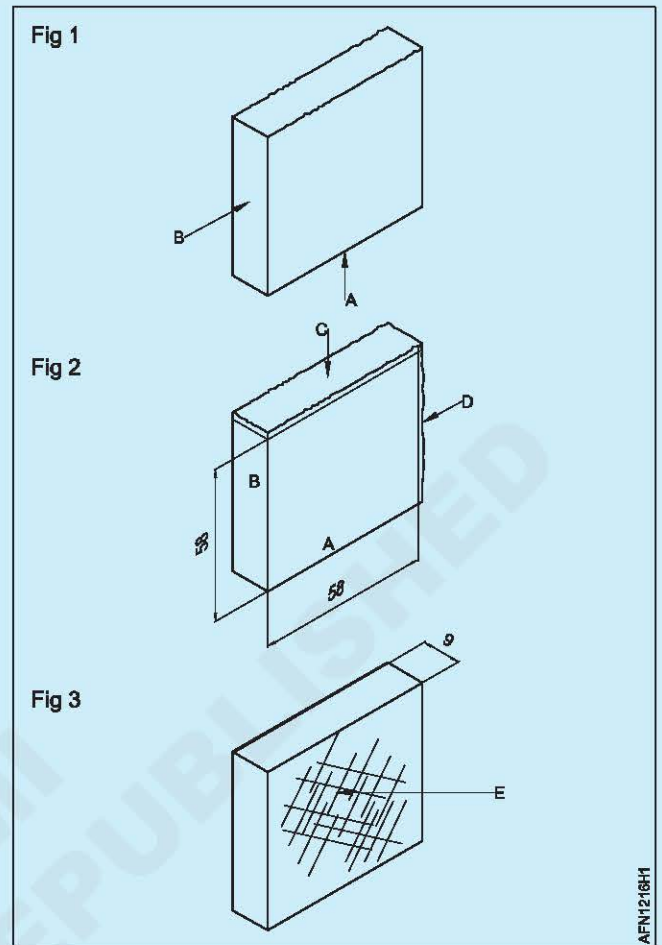

Skill sequence

Marking parallel lines using surface gauge

Objective: This shall help you to

- **mark parallel lines using a surface gauge.**

Check the free movement of the scribe and other sliding units.

Clean the base of the surface gauge.

Keep the base firmly on the surface plate.

Rest the steel rule against the angle plate and set the scribe to the size to be marked. (Fig 1)

Make sure that the job has no burrs and has been properly cleaned.

Apply a thin and even coating of the marking media.

Butt the job against the angle plate.

Hold the job in one hand and move the scribe point touching the surface across the work and mark. (Fig 2)

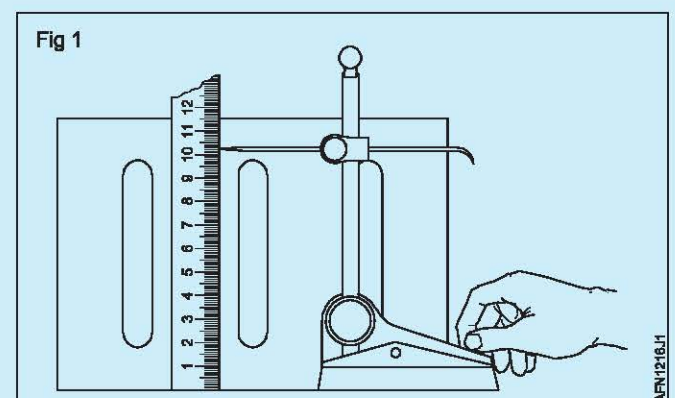

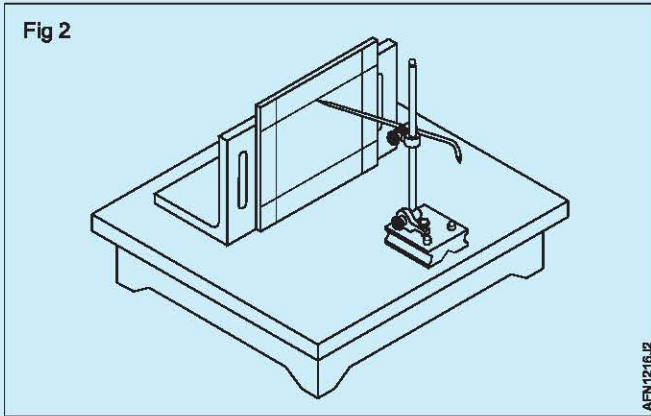

Marking with a vernier height gauge

Objective: This shall help you to

- mark with a vernier height gauge.

What is the main function of the vernier height gauge?

One of the primary functions of the vernier height gauge is to scribe lines on a workpiece to known heights.

How to use a vernier height gauge?

The height gauge scribe must be checked against the reference surface to confirm whether the zero of the vernier coincides with the zero of the beam scale when the scribe contacts the reference surface. (Fig 1)

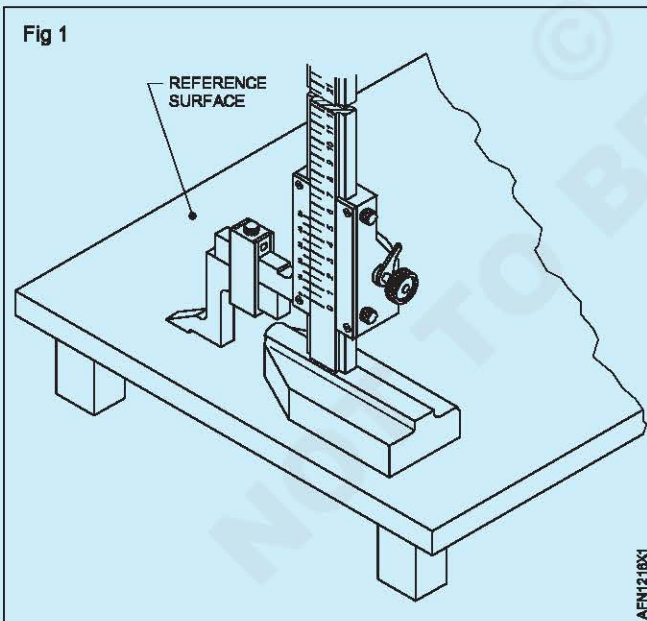

Check for free movements of the sliding unit.

Make sure that the workpiece has no burr and has been properly cleaned.

Keep the vernier height gauge base firmly on the surface plate.

Hold the scribe at an angle to the workpiece and pull the corner of the scribe across the work. (Fig 2)

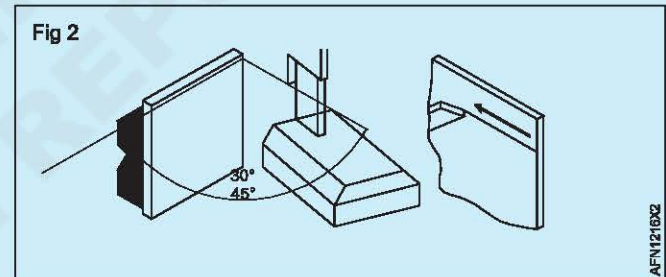

Do not allow the base to lift.

Do not apply too much pressure to peel off metal from the workpiece. This will avoid damage to the scribe point.

Scribe first all lines of dimensions in one direction.

Ensure the scribe point is always sharp.

Burrs should be removed before checking.

Filing steps and notches to accuracy of ± 0.5 mm

Objectives: At the end of this exercise you shall be able to

- sawing and filing steps and notches
- tracing with vernier height gauge.
- check dimension with vernier calliper and vernier depth gauge.

TASK 1

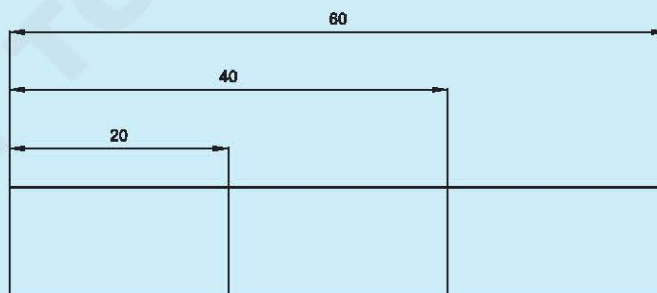
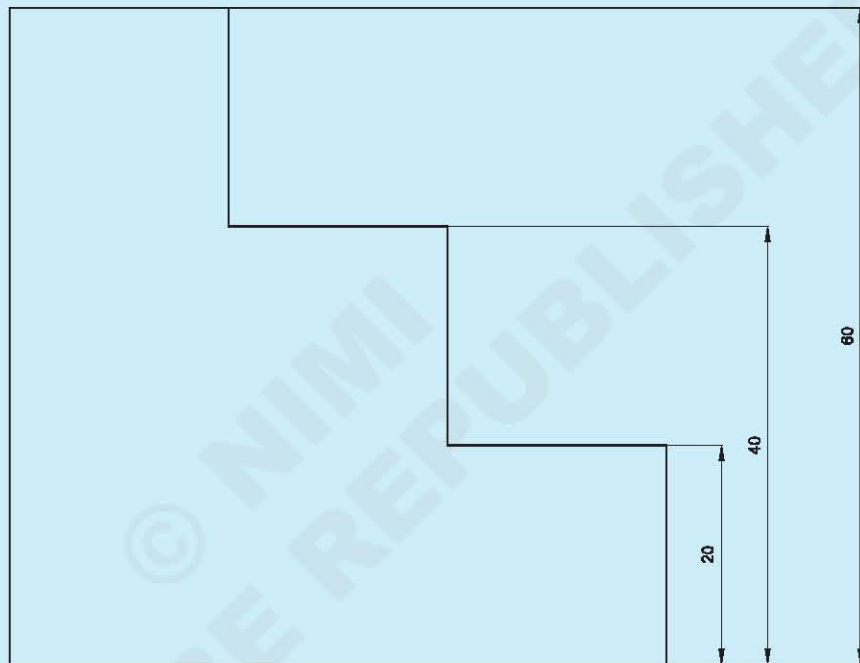

1	60 x 60 x 10		A2017	-	TASK-1	1.2.14B
NO.OFF	STOCK SIZE	SEMI-PRODUCT	MATERIAL	PROJECT NO.	PART NO.	EX. NO.
SCALE	FILING STEPS AND NOTCHES WITH AN ACCURACY OF ± 0.5				DEVIATIONS	TIME: 5-HOURS
					CODE NO: AFN1214E2	

TASK 2

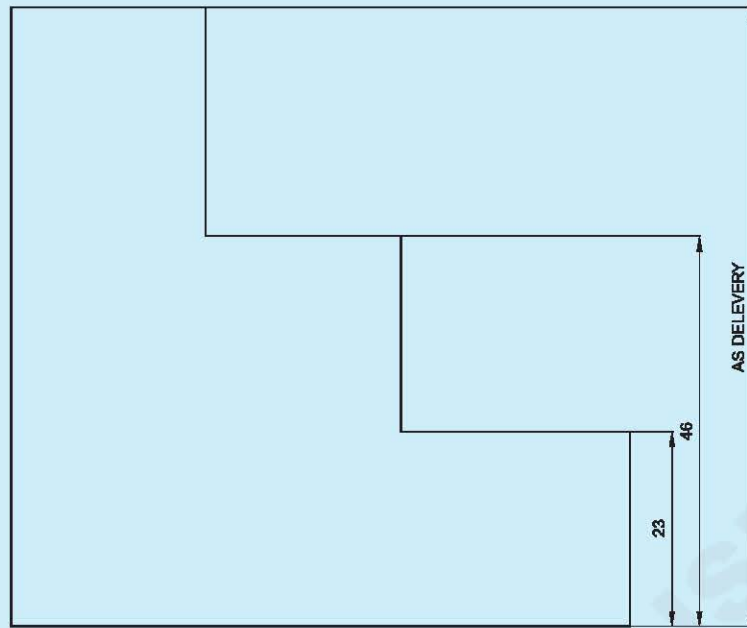

1	73 x 73 x 1.5	> 1.2.13	A2024	-	TASK-2	1.2.14B
NO.OFF	STOCK SIZE	SEMI-PRODUCT	MATERIAL	PROJECT NO.	PART NO.	EX. NO.
SCALE	FILING STEPS AND NOTCHES WITH AN ACCURACY OF +/-0.5				DEVIATIONS	TIME: 5HOURS
					CODE NO: AFN1214E3	

PROCEDURE

TASK 1: **Steps in thick sheet metal**

1 Check the raw material size using steel rule.

4 Deburr edges.

File references

Marking - Fig 1

2 File flat and straight by draw filing the 4 surfaces.

5 Mark the steps with vernier height gauge as per drawing.

3 Check flatness and squareness.

Sawing and filing the first step - Fig 2

- 6 Cut and separate the excess material by sawing.
- 7 File the step with safe edge file using bastard, second cut and smooth grades maintaining the accuracy of ± 0.5 mm.
- 8 Measure the job sizes with vernier calliper and vernier depth gauge.
- 9 Check the squareness with square

Sawing and filing the second step - Fig 3

- 10 Similarly, cut and separate the excess material by sawing.
- 11 File step with safe edge file using different grades maintaining the accuracy of ± 0.5 mm.
- 12 Measure the job size with vernier calliper and vernier depth gauge.
- 13 Check the squareness with try square
- 14 Finish by draw filing and deburr.

Fig 1

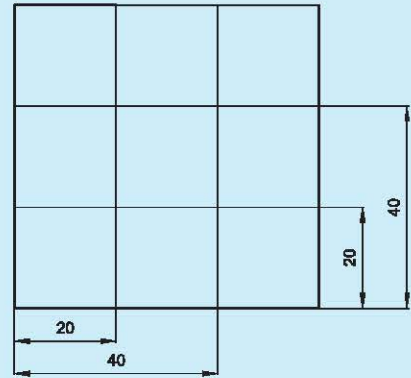

Fig 2

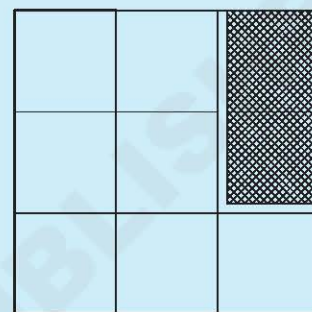
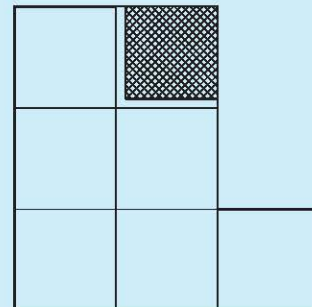

Fig 3



AFN1214/NT

TASK 2: Steps in thin sheet metal

- 1 Check the raw material size using steel rule (Fig 1).

Marking

- 2 Mark the steps with vernier height gauge as per drawing.

Sawing and filing the first step - Fig 2

- 3 Cut and separate the excess material by sawing.
- 4 File the step with safe edge file using bastard, second cut and smooth grades maintaining the accuracy of ± 0.5 mm.

- 5 Measure the job sizes with vernier calliper and vernier depth gauge.

- 6 Check the squareness with square

Sawing and filing the second step - Fig 3

- 7 Similarly, cut and separate the excess material by sawing.
- 8 File step with safe edge file using different grades maintaining the accuracy of ± 0.5 mm.

- 9 Measure the job size with vernier calliper and vernier depth gauge.
- 10 Check the squareness with try square
- 11 Finish by draw filing and deburr.

Fig 1

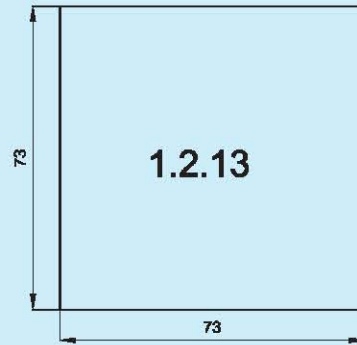

Fig 2

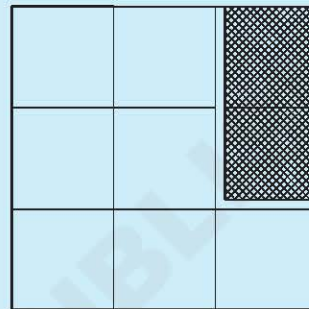
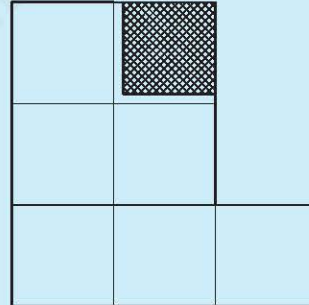

Fig 3



AFN121401

Filing chamfers to accuracy of ±0.5 mm

Objectives: At the end of this exercise you shall be able to

- filing chamfer
- tracing with vernier height gauge and protractor
- check dimension with bevel protractor.

TASK 1

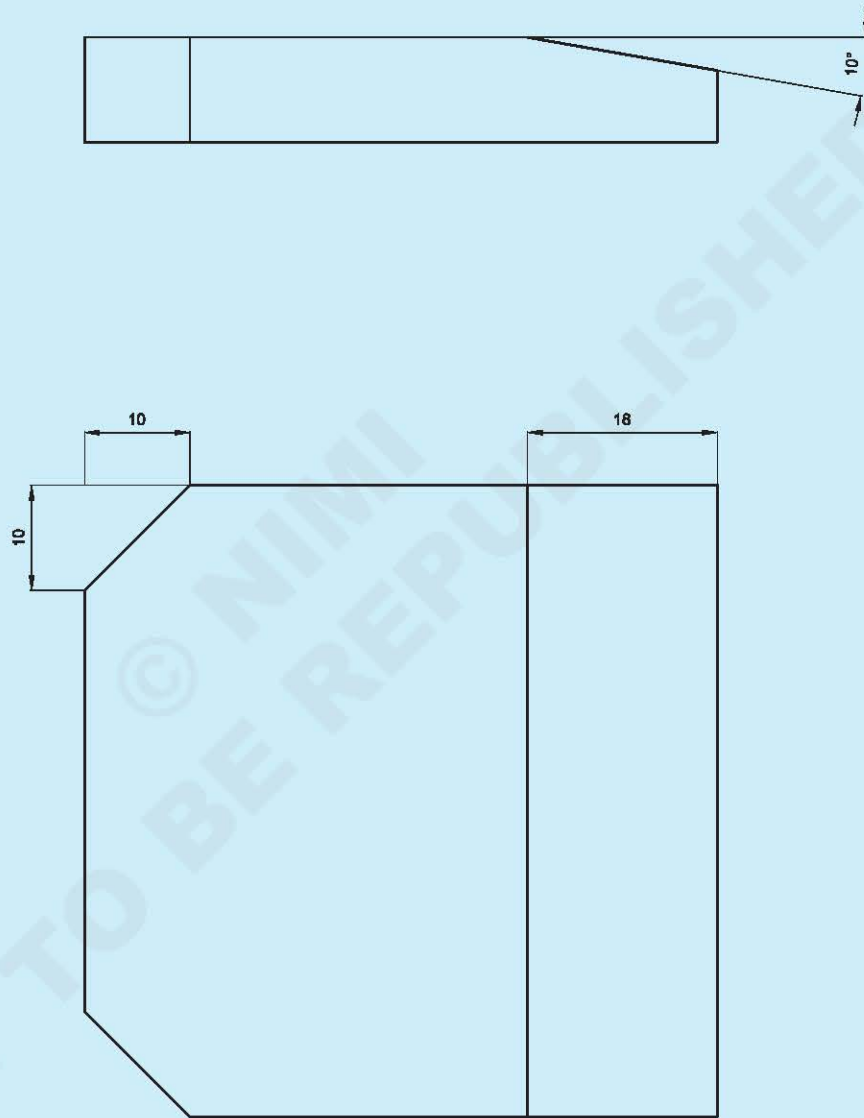

1	60 x 60 x 10	-	A2017	-	TASK-1	1.2.14C
NO.OFF	STOCK SIZE	SEMI-PRODUCT	MATERIAL	PROJECT NO.	PART NO.	EX. NO.
SCALE	FILING CHAMFERS WITH AN ACCURACY OF +/-0.5				DEVIATIONS	TIME: 5HOURS
					CODE NO: AFN1214E4	

TASK 2

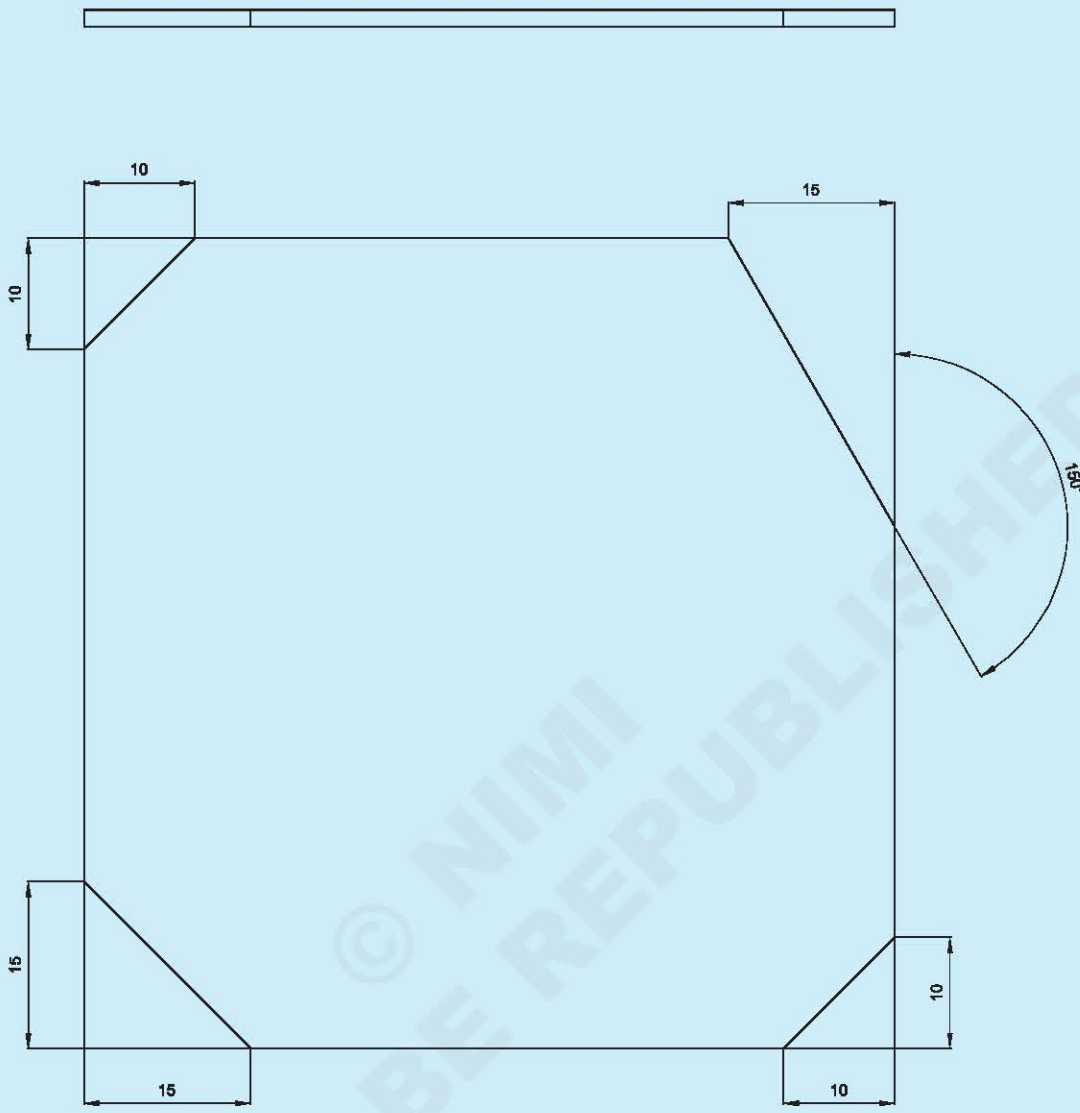

1	73 x 73 x 1.5	> 1.2.13	A2024	-	TASK-2	1.2.14C
NO.OFF	STOCK SIZE	SEMI-PRODUCT	MATERIAL	PROJECT NO.	PART NO.	EX. NO.
SCALE : NTS					DEVIATIONS	
<p align="center">FILING CHAMFERS WITH AN ACCURACY OF +/-0.5</p>					TIME: 4HOURS	
					CODE NO: AFN1214E5	

PROCEDURE

TASK 1: Make chamfer in thick part

- 1 Check the raw material size using steel rule.

File references

- 2 File flat and straight by draw filing the 4 surfaces.
- 3 Check flatness and squareness.
- 4 Deburr edges.

Filing chamfer on angle

- 5 Mark the two chamfers of 10x10 with vernier height gauge and protractor. (Fig 1)
- 6 File the chamfer using bastard, second cut and smooth grades maintaining the accuracy of ± 0.5 mm.

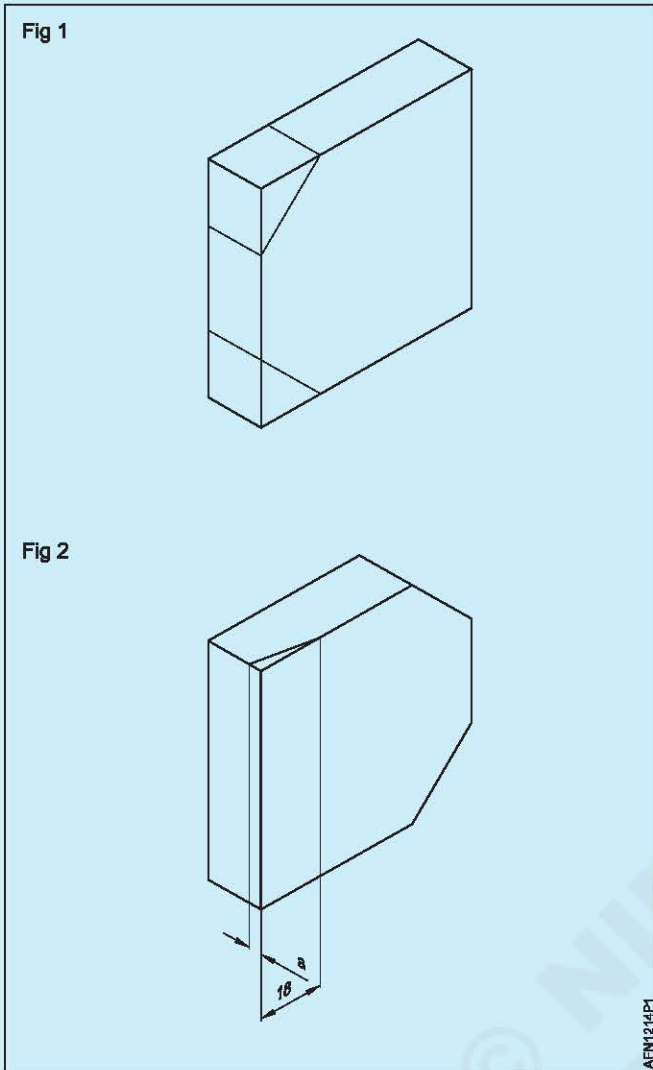

- 7 Measure the job sizes with vernier calliper and bevel protractor.
- 8 Finish by draw filing and deburr.
- 9 Check the squareness with square.

Filing chamfer on long edge

- 10 Mark the chamfer of 18 mm x10° with vernier height gauge and protractor. (Fig 2)

NOTE: To facilitate tracing, calculate the value "a" using trigonometric calculation or the Pythagorean theorem.

- 11 File the chamfer using bastard, second cut and smooth grades maintaining the accuracy of ± 0.5 mm.
- 12 Measure the job sizes with vernier calliper and bevel protractor.
- 13 Finish by draw filing and deburr.
- 14 Check the squareness with square.

TASK 2: Make chamfer in thin sheet metal part

- 1 Check the raw material size using steel rule (Fig 3).

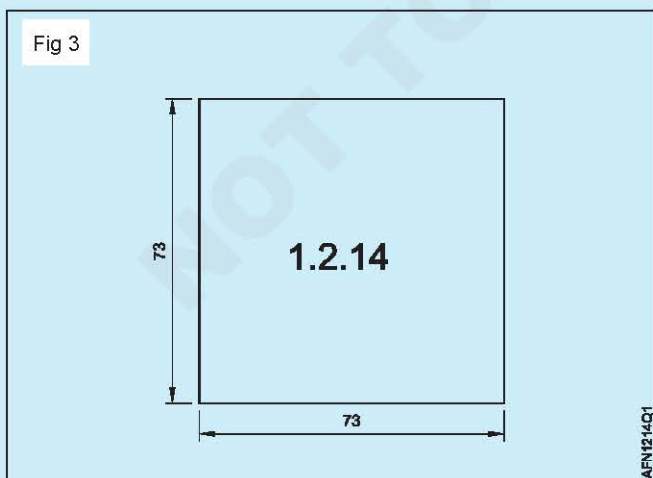

Tracing and filing chamfers

- 2 Mark the two chamfers of 10x10 with vernier height gauge and protractor.
- 3 Mark the chamfers of 15x15 with vernier height gauge and protractor.
- 4 Mark the chamfers of 15x15° with vernier height gauge and protractor.
- 5 File the chamfers using bastard, second cut and smooth grades maintaining the accuracy of ± 0.5 mm.
- 6 Measure the job sizes with vernier calliper and bevel protractor.
- 7 Finish by draw filing and deburr.
- 8 Check the squareness with square.

Skill sequence

Clamping the workpiece in the bench vice to chamfering

Objective: This shall help you to

- **clamp a workpiece in good position to make a chamfer.**

Set the correct position of the workpiece.

- Hold the workpiece in the bench vice with a minimum projection from the top of the vice jaw without touching the vice.
- The workpiece must be in the centre of the jaws.
- Hold the workpiece with the chamfer angle to facilitate the flat filing. (Fig 1)
- Close the jaws of the bench vice to tighten the workpiece lightly by turning the handle in clockwise direction.

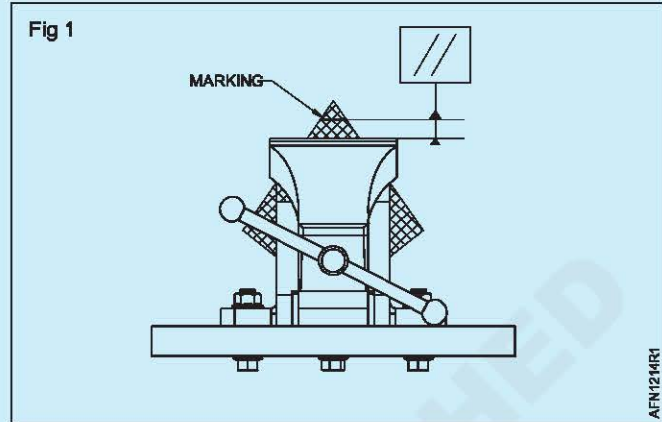

Filing a chamfer

Objective: This shall help you to

- **file a chamfer.**

During filing, the parallel position must be ensured.

It is possible to check visually by looking at the filed face to ensure that it is a perfect rectangle. (Fig 1)

Indeed, if the shape is a trapezoid, it means that the adjustment is inclined. (Fig 2)

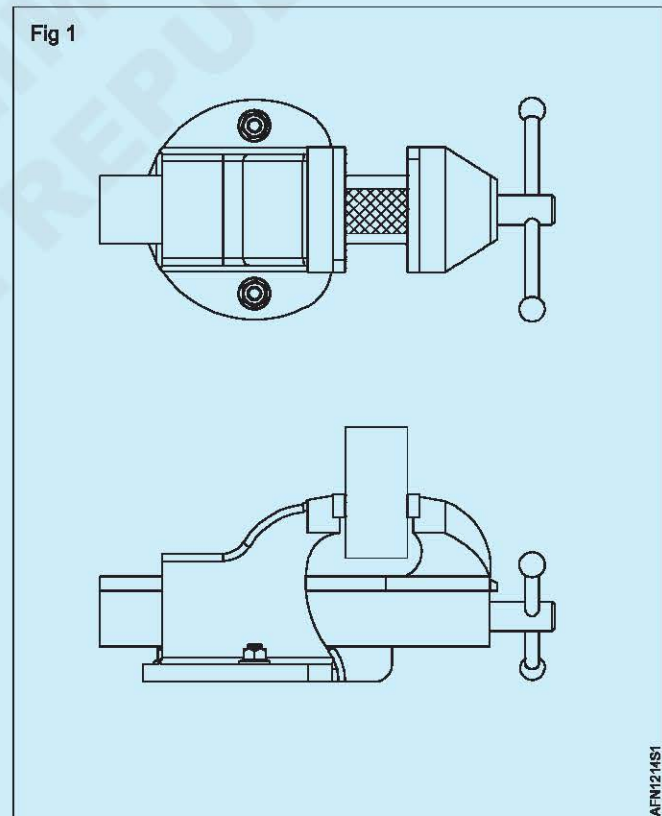

Filing convex radii

Objectives: At the end of this exercise you shall be able to

- filing radius
- tracing with vernier height gauge and fillet gauge
- check radius with fillet gauge.

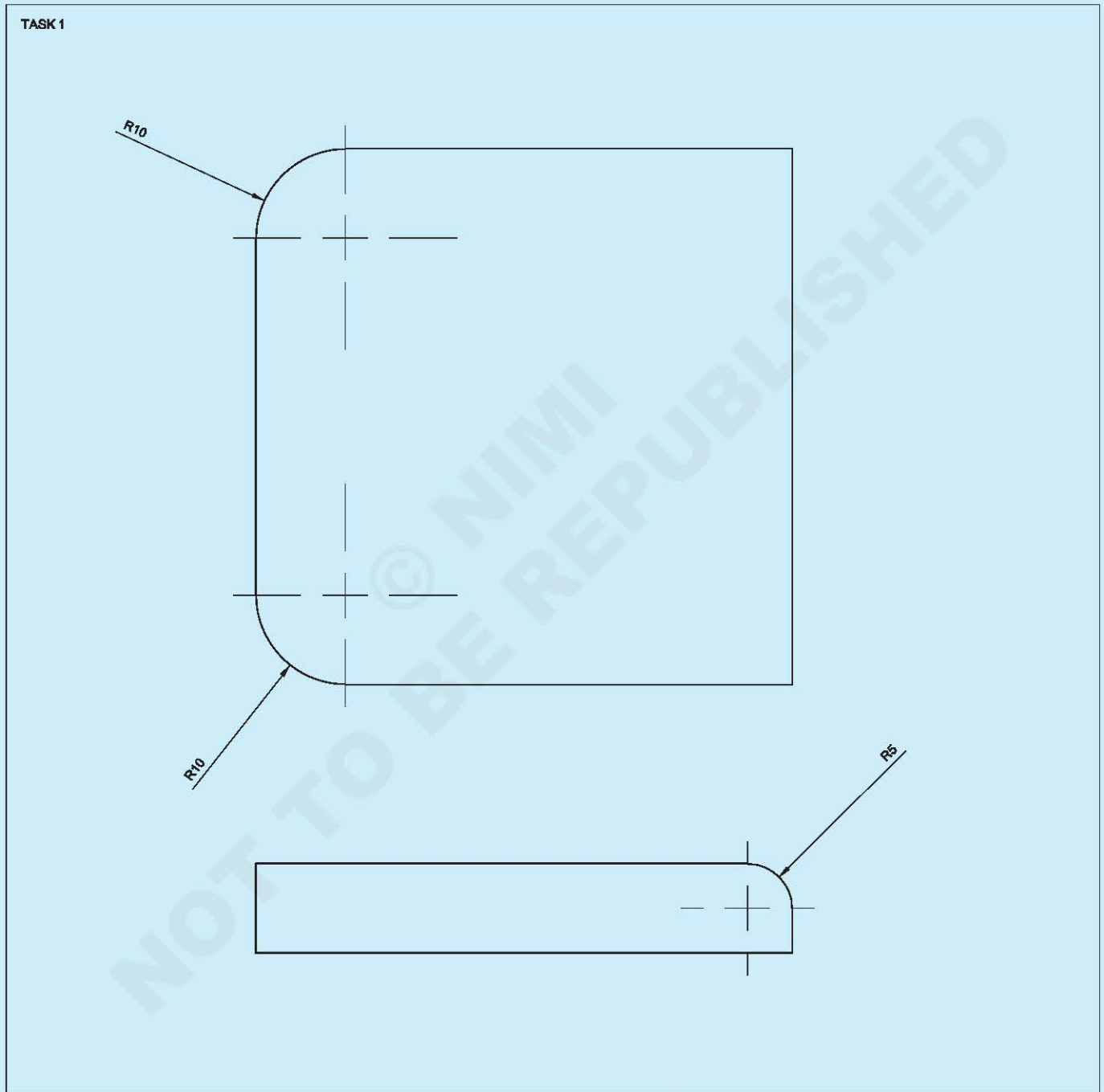

1	60 x 60 x 10	--	A2017	--	TASK-1	1.2.14D
NO.OFF	STOCK SIZE	SEMI-PRODUCT	MATERIAL	PROJECT NO.	PART NO.	EX. NO.
SCALE		FILING CONVEX RADII			DEVIATIONS	TIME: 5HOURS
					CODE NO: AFN1214E6	

TASK 2

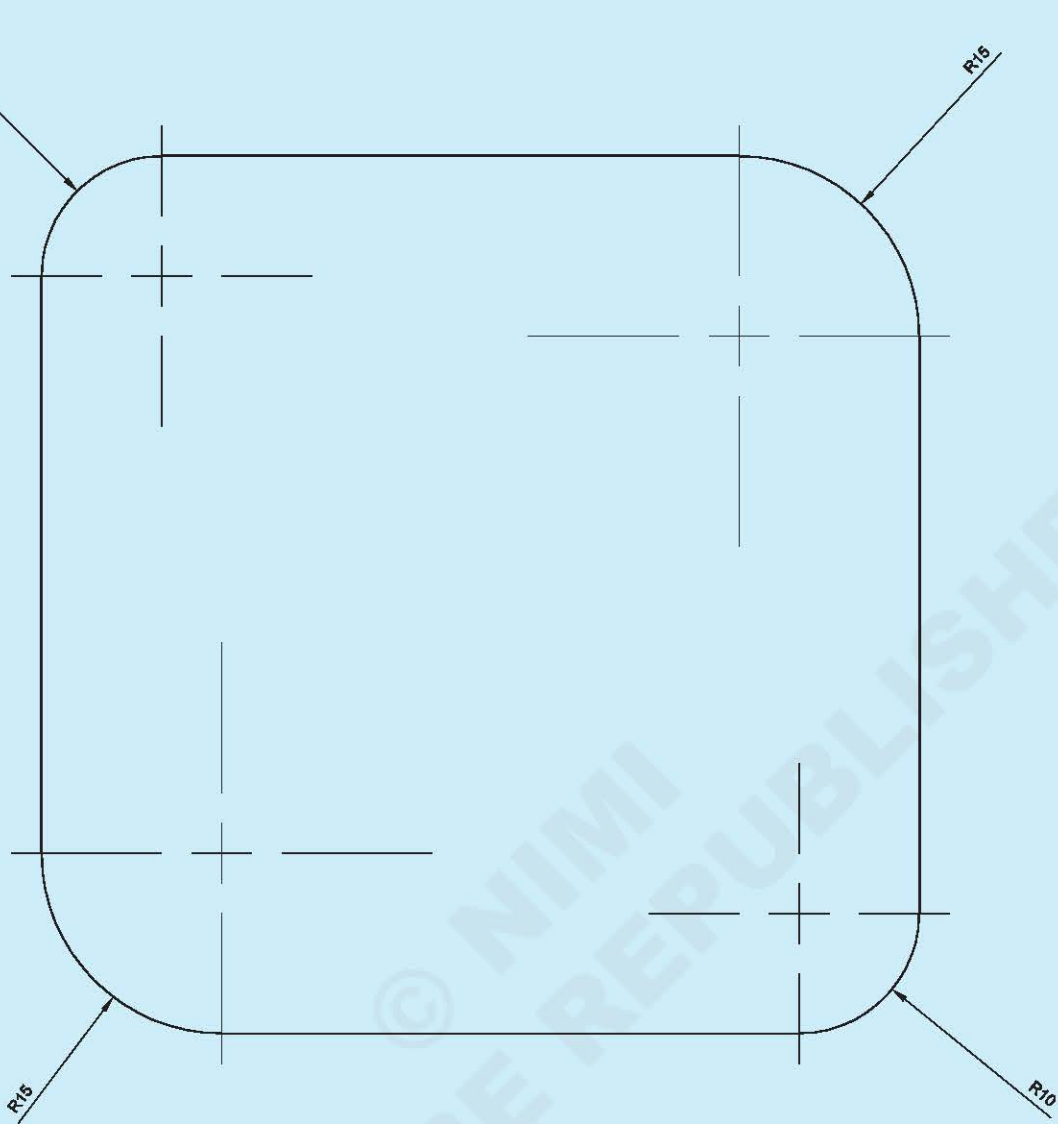

1	73 x 73 x 1.5	> 1.2.13	A2024	-	TASK-2	1.2.14D
NO.OFF	STOCK SIZE	SEMI-PRODUCT	MATERIAL	PROJECT NO.	PART NO.	EX. NO.
SCALE	FILING CONVEX RADII				DEVIATIONS	TIME: 5HOURS
					CODE NO: AFN1214E7	

PROCEDURE

TASK 1: Make radii on thick part

1 Check the raw material size using steel rule.

4 Deburr edges.

File references

Filing radii on angle

2 File flat and straight by draw filing the 4 surfaces.

5 Mark the two radii of R10 with vernier height gauge and divider. (Fig 1)

3 Check flatness and squareness.

- 6 File the radii using bastard, second cut and smooth grades maintaining the accuracy of ± 0.5 mm.
- 7 Measure the job sizes with fillet gauge.
- 8 Finish by draw filing and deburr.

Filing radius on long edge

- 9 Mark the limits of the radius with vernier height gauge. (Fig 2)

NOTE: To facilitate filing, you can calculate the value "a" of the first chamfer using trigonometric calculation or the Pythagorean theorem. (Fig 3)

- 10 File the radius using bastard, second cut and smooth grades maintaining the accuracy of ± 0.5 mm.

- 11 Measure the job sizes with fillet gauge.

- 12 Finish by draw filing and deburr.

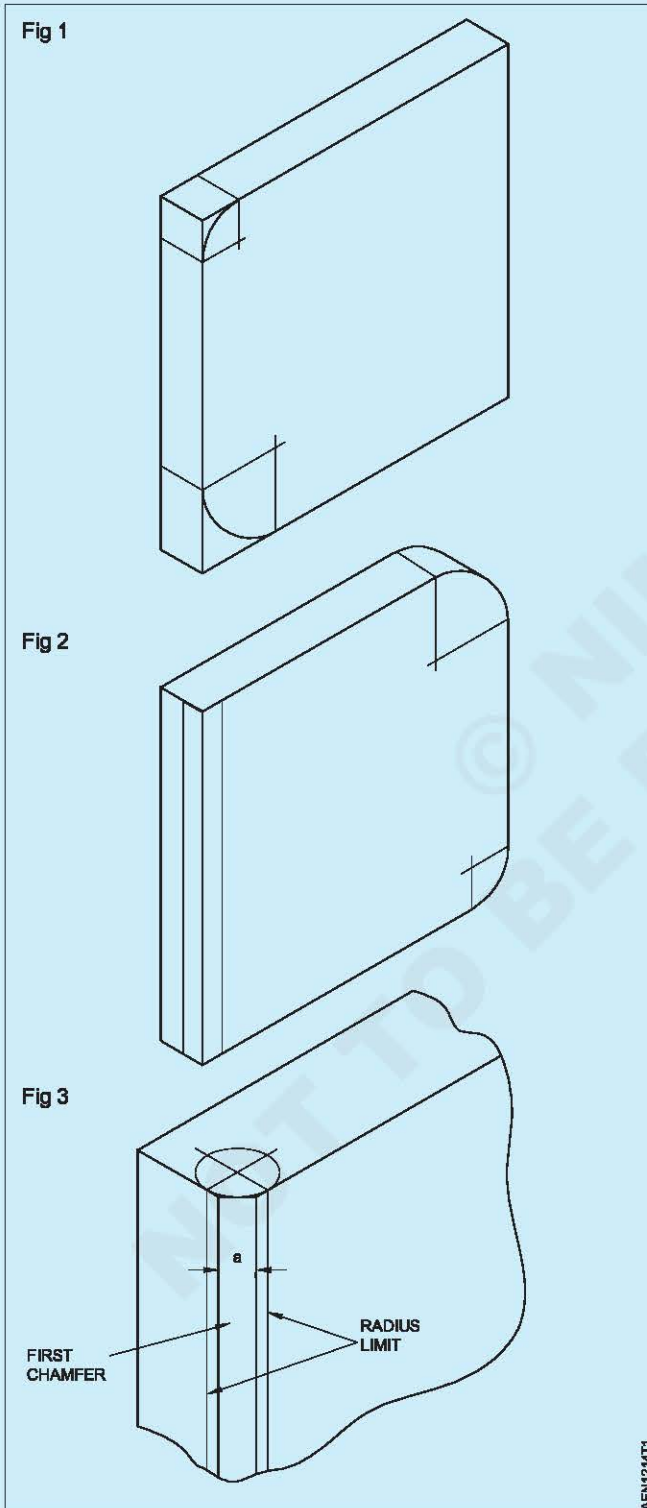

TASK 2: Make radii on thin sheet metal

1 Check the raw material size using steel rule (Fig 4).

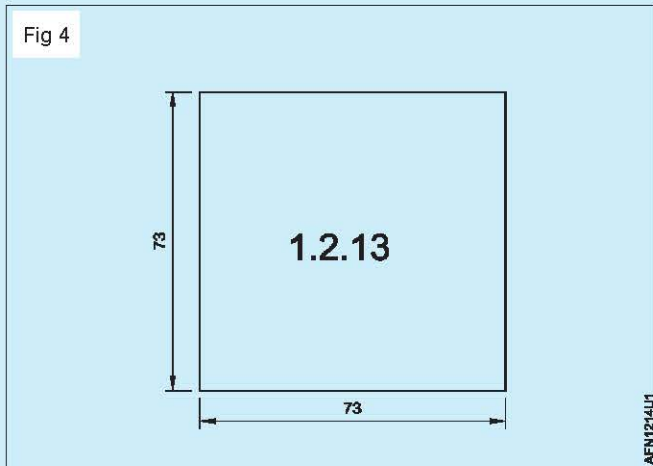

Filing radii on angle

- 2 Mark the two radii of R10 with vernier height gauge and divider.
- 3 Mark the two radii of R15 with vernier height gauge and divider.
- 4 File the radii using bastard, second cut and smooth grades maintaining the accuracy of ± 0.5 mm.
- 5 Measure the job sizes with fillet gauge.
- 6 Finish by draw filing and deburr.

Skill sequence

Punch centre to use divider

Objective: This shall help you to

- punch a dot mark using a dot punch.

Place the sheet on the anvil stake. Hold the punch between the thumb and the first two fingers of the hand where possible, rest the little finger and the edge of your hand on the marked centre point as shown in Fig 1.

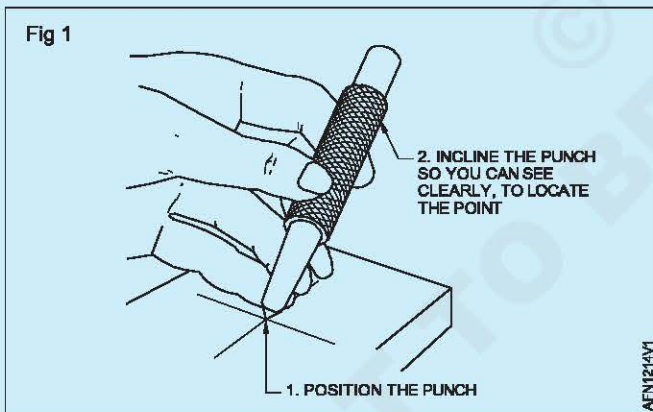

Bring up the dot punch in the vertical position and strike with a ball peen hammer on the head of the dot punch lightly.

Watch the point of the punch and strike its head with the hammer Fig 2.

This dot punch marks prevent the divider leg from slipping while scribing curved lines from the centre point.

Only a small dot is needed to prevent the divider from slipping. If the dot is too big, compass leg will wander.

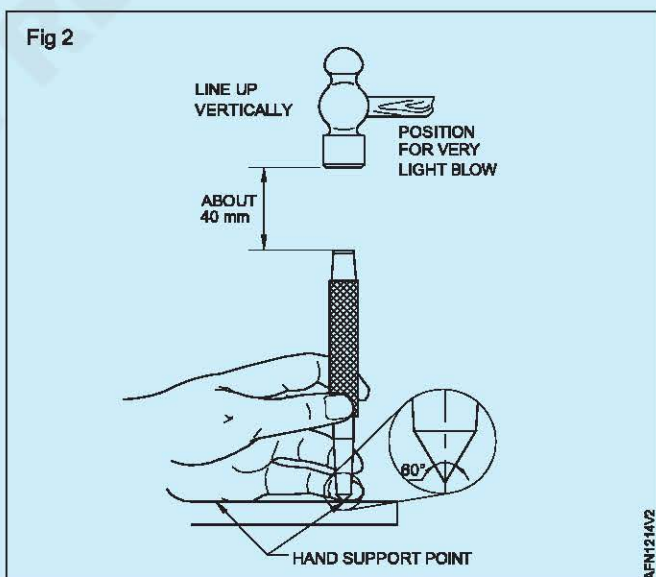

Marking with divider

Objective: This shall help you to

- draw circles and arcs with a divider.

Verify that the legs of the divider are of the same length. (Fig 1)

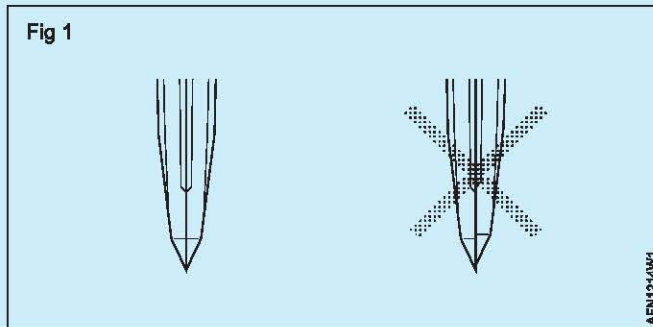

If not, grind the leg and sharpen with an oilstone.

Punch at the intersection of the marked lines.

Only a small dot is needed to prevent the compass from slipping.

While adjusting the compass opening, use the middle of the rule and not the edge.

For larger lengths, place the rule on the worktable and adjust the divider opening, with both tips on the rule. (Fig 2)

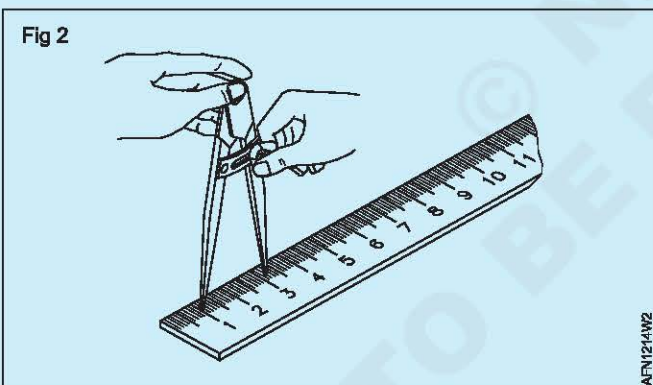

After setting the dimensions, lock the legs and check the dimensions again.

Hold the compass head with the palm of your hand to prevent the compass point from slipping from the centre of the circle.

Draw an upper half circle from the lower left to the right, using thumb pressure. (Fig 3)

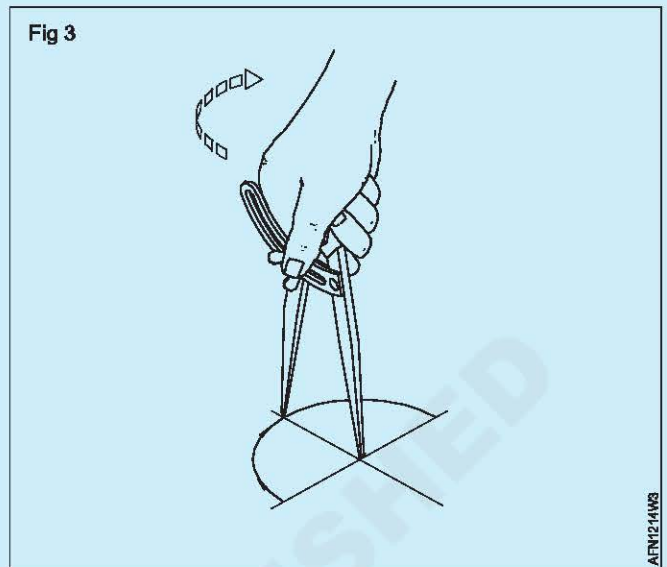

Change the thumb position on the compass and draw the rest of the circle from the lower left. (Fig 4)

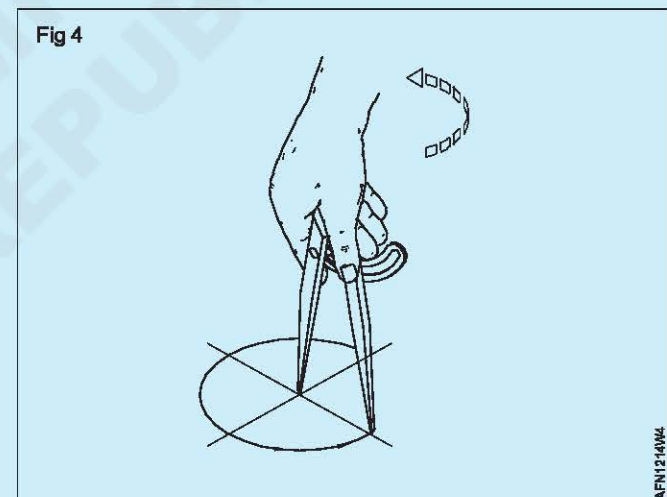

When the drawing, tilt the compass slightly in the direction of rotation.

Filing a radius

Objective: This shall help you to

- file a radius.

Set the workpiece in the vice as shown in Figure 1.

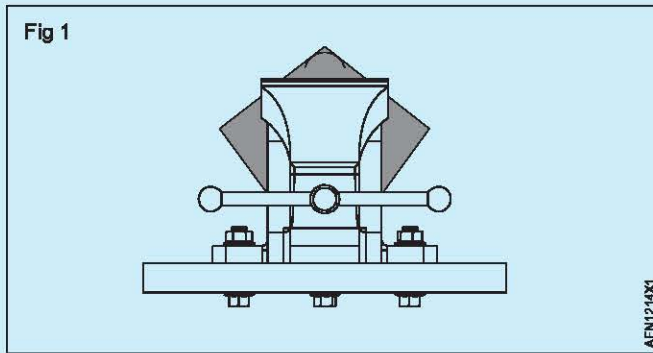

File a chamfer until it is tangential to the radius line. Check the shape (rectangular or trapezoidal) to ensure parallel filing. (Fig 2)

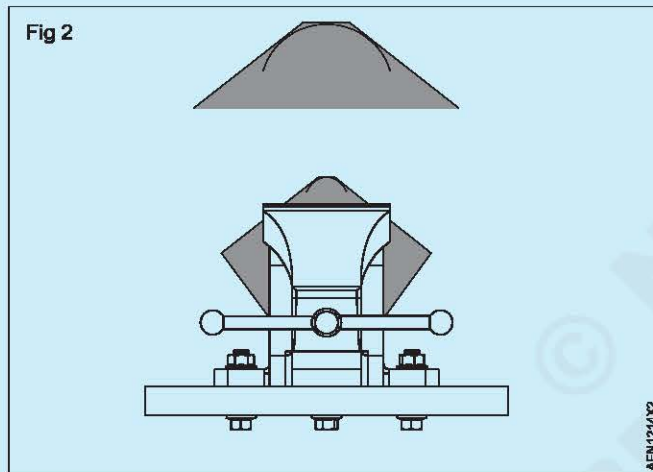

Rotate the part to place a tip upwards and file a chamfer. (Fig 3)

The filing must come tangential to the line.

Repeat the operation on the other tip. (Fig 4)

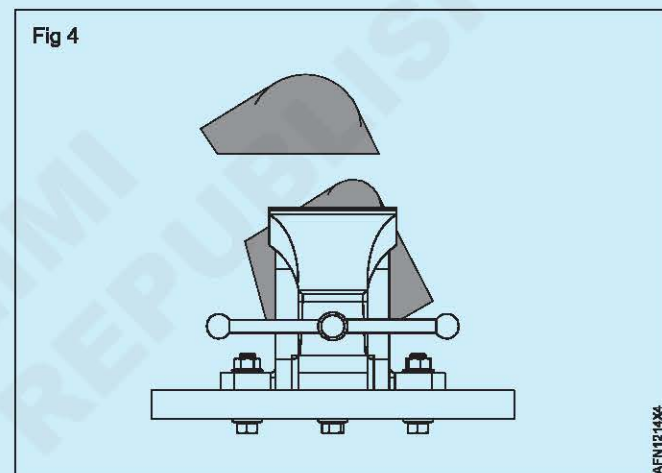
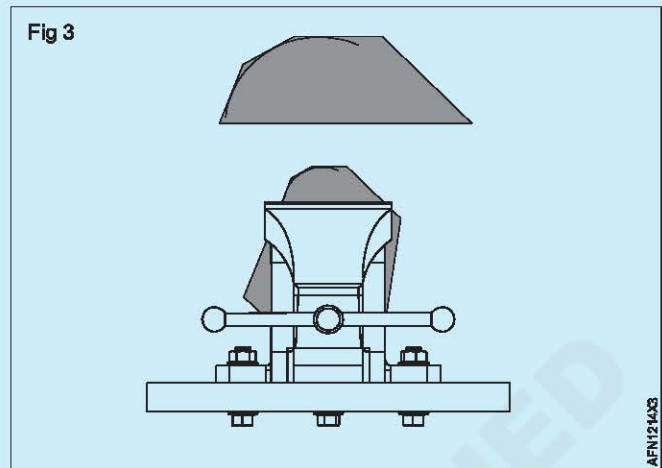

Depending on the size of the radius, repeat the operation until the chamfers are as small as possible.

Finish by draw filing.

Check with fillet gauge.

Drilling with drill press

Objectives: At the end of this exercise you shall be able to

- set the drill bit in drill press chuck
- calculate the cutting speed
- drill holes with drill press.

TASK 1

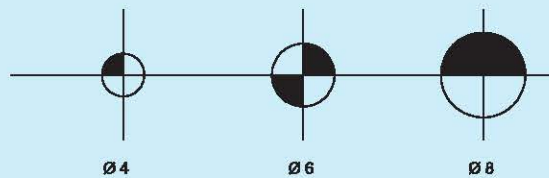
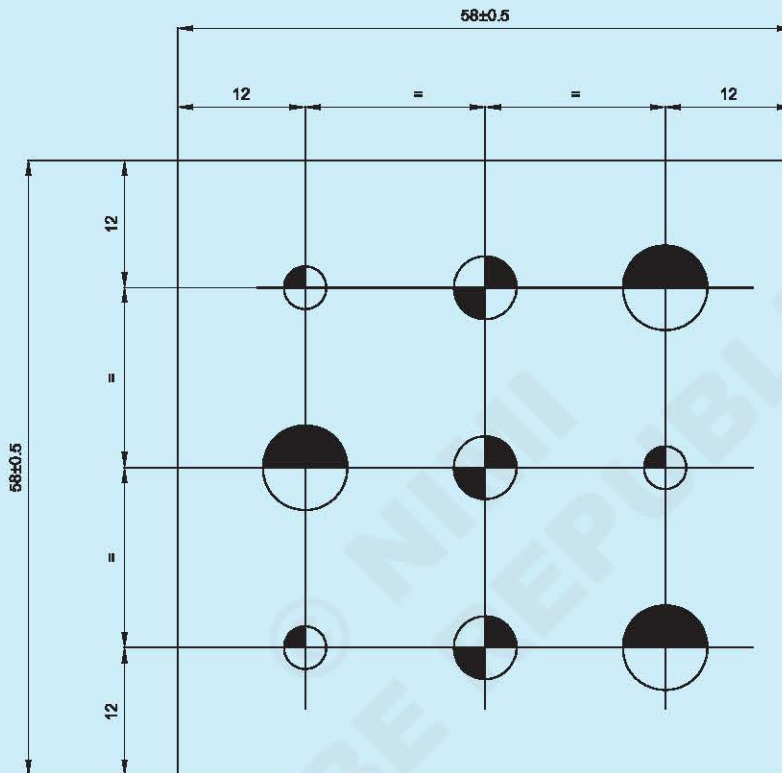

1	-	> 1.2.16A	A2017	-	TASK-1	1.2.14E
NO.OFF	STOCK SIZE	SEMI-PRODUCT	MATERIAL	PROJECT NO.	PART NO.	EX. NO.
SCALE	DRILLING WITH DRILL PRESS				DEVIATIONS	TIME: 5 HOURS
					CODE NO: AFN1214E3	

TASK 2

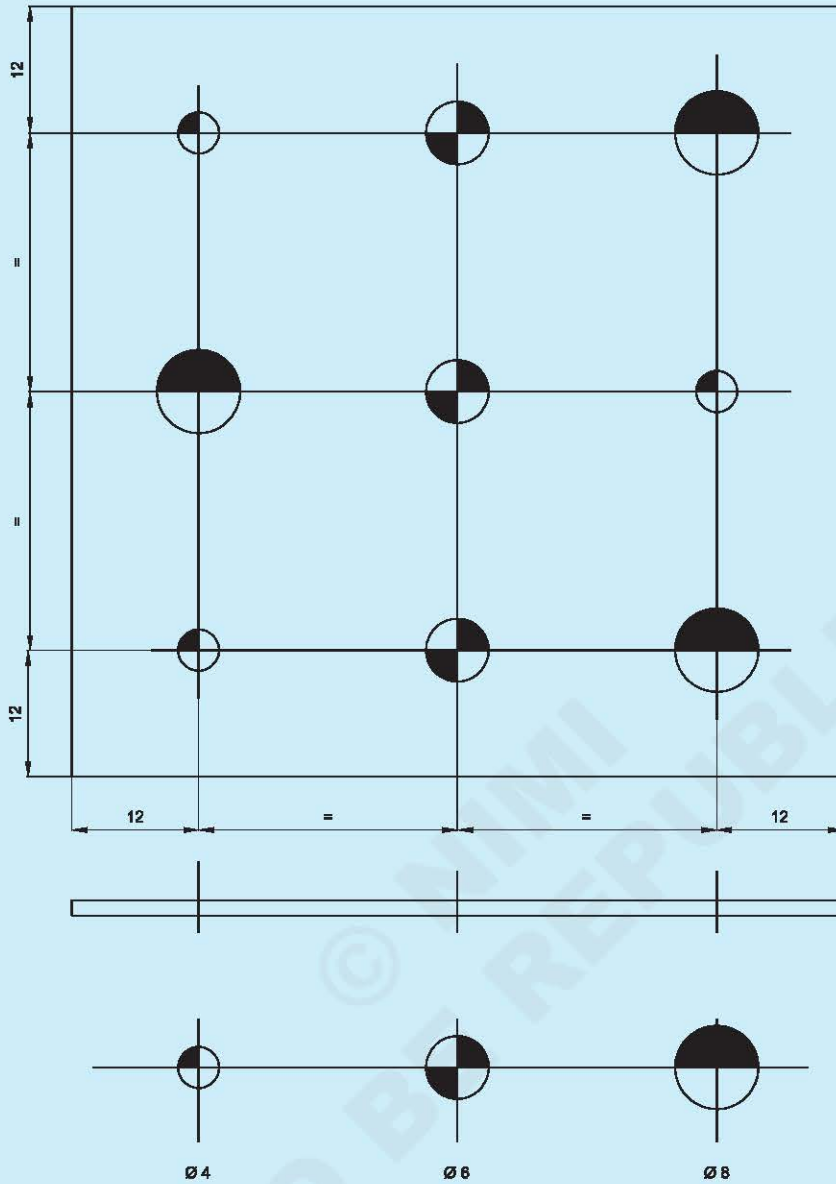

1	73 x 73 x 1.5	> 1.2.13	A2024	-	TASK-2	1.2.14E
NO.OFF	STOCK SIZE	SEMI-PRODUCT	MATERIAL	PROJECT NO.	PART NO.	EX. NO.
SCALE		DRILLING WITH DRILL PRESS			DEVIATIONS	TIME: 5HOURS
					CODE NO: AFN1214E9	

PROCEDURE

TASK 1: Drilling thick part

- 1 Check the raw material.
- 2 Trace the lines.
- 3 Punch the centre of the holes.
- 4 Position and hold the workpiece in the vice in position.
- 5 Calculate the drilling speed and adjust the drill press.
- 6 Drill all the holes at 3 mm.
- 7 Counter-drill to the final diameter.
- 8 Deburr both side with 90° countersinking cutter.

TASK 2: Drilling thin sheet metal

1 Check the raw material. (Fig 1)

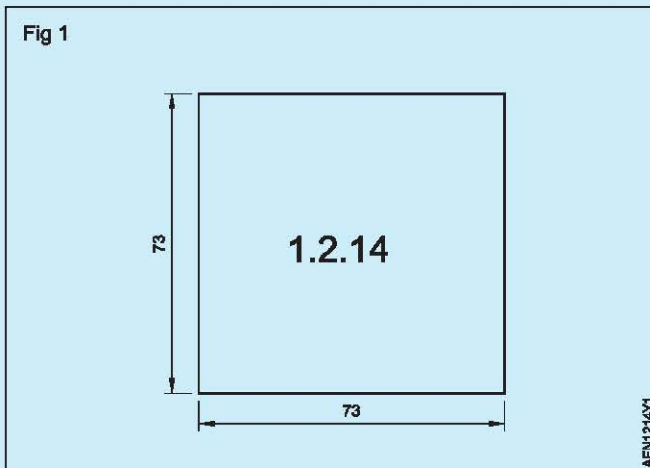

- 2 Trace the lines.
- 3 Punch the centre of the holes.
- 4 Position and hold the workpiece with clamps in 5 Drill all the holes at 3 mm.
- 6 Counter-drill to the final diameter.
- 7 Deburr both side with 90° countersinking cutter.

Skill sequence

Holding devices

Objective: This shall help you to

- identify and use the different holding devices.

Workpieces to be drilled should be properly held or clamped to prevent from rotating along with the drill.

Improperly secured work is not only a danger to the operator but can also cause inaccurate work, and breakage to the drill. Various devices are used to ensure proper holding.

The machine vice

Most of the drilling work can be held in a machine vice.

Ensure that the drill does not drill through the vice after it has passed through the work. For this purpose, the workpiece can be lifted and secured on parallel blocks providing a gap between the work and the bottom of the vice. (Fig. 1)

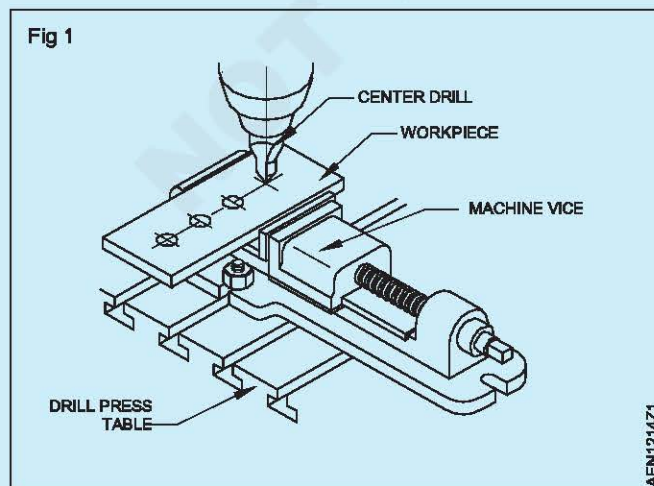

Clamps and bolts

Drilling machine tables are provided with T-Slots for fitting bolt heads. Using clamps and bolts, the workpiece can be held very rigidly. (Fig 3)

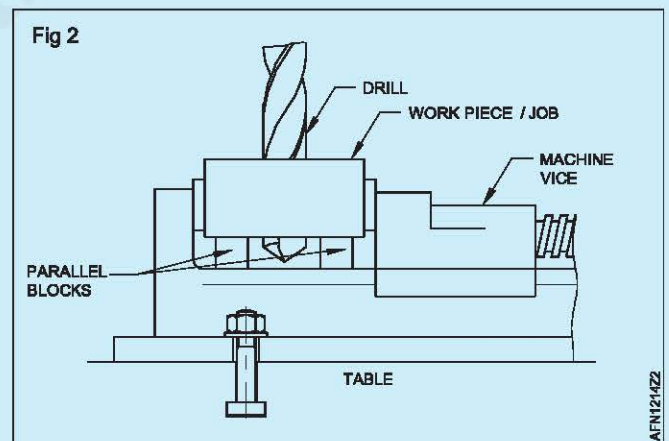

Use a Sacrificial Board

A sacrificial board is a flat piece of wood that you place under something you're drilling. You drill through it when making the hole.

When drilling thin sheet metal, clamp the metal over a piece of sacrificial board (flat sheet good, like MDF or particleboard) to help to prevent the bit from tearing up the hole.

Fig 3

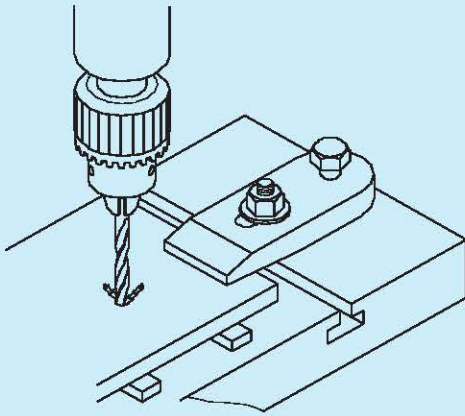

AFM121423

© NIMI
NOT TO BE REPUBLISHED

Make countersink, counterbore and spot face

Objectives: At the end of this exercise you shall be able to

- countersink hole
- counterbore hole
- spot face surface.

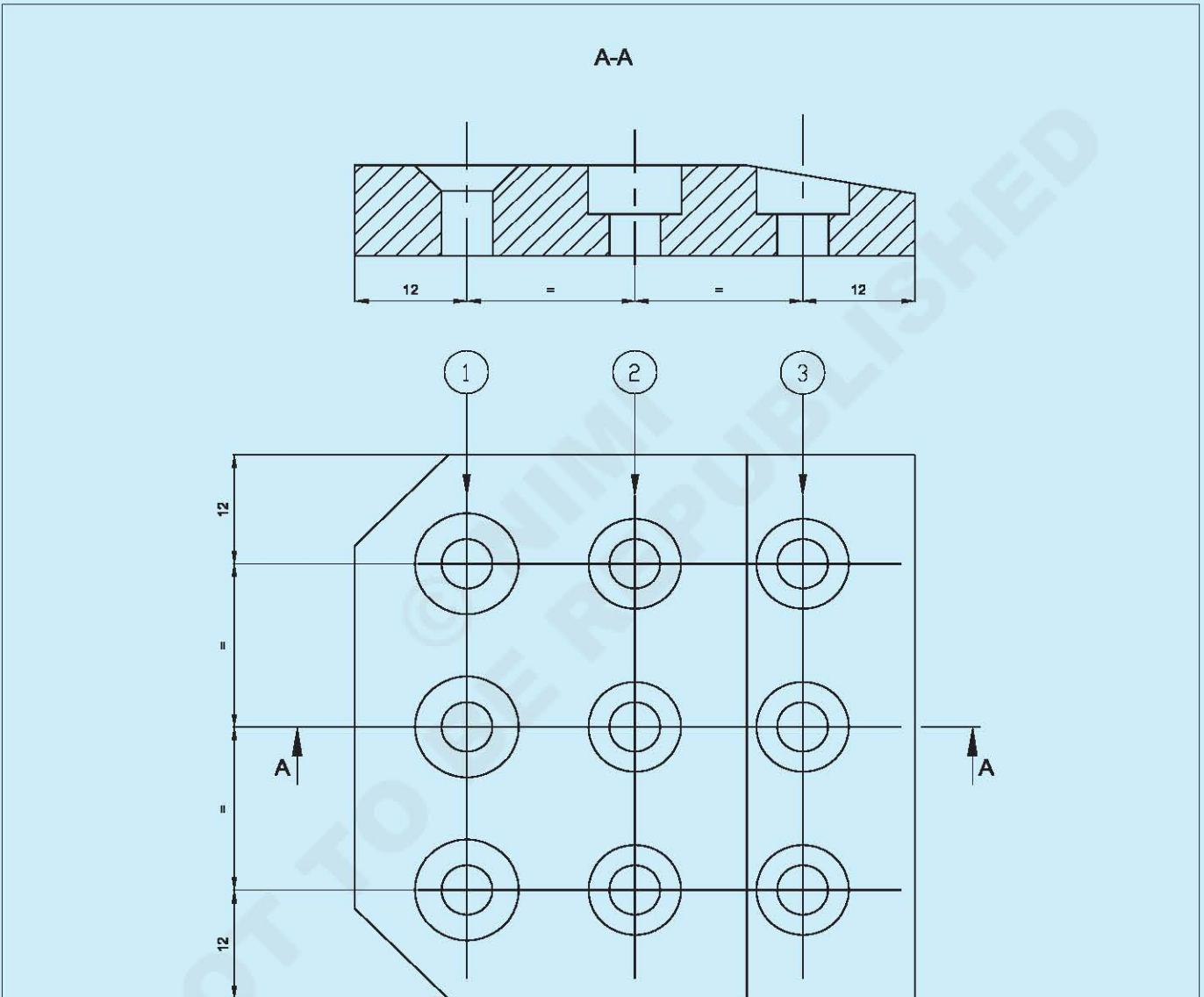

1	-	> 1.2.16C	A2017	--	TASK-1	1.2.16F
NO.OFF	STOCK SIZE	SEMI-PRODUCT	MATERIAL	PROJECT NO.	PART NO.	EX. NO.
SCALE	MAKE COUNTERSINK, COUNTERBORE AND SPOT FACE				DEVIATIONS	TIME: 10:HRS
					CODE NO: AFN1216E2	

Job Sequence

Tracing and drilling

- In the flat face (Fig 1), mark the holes positions.
- Punch the centre.
- Hold the workpiece and drill holes to diameter 4.
- Deburr both sides.

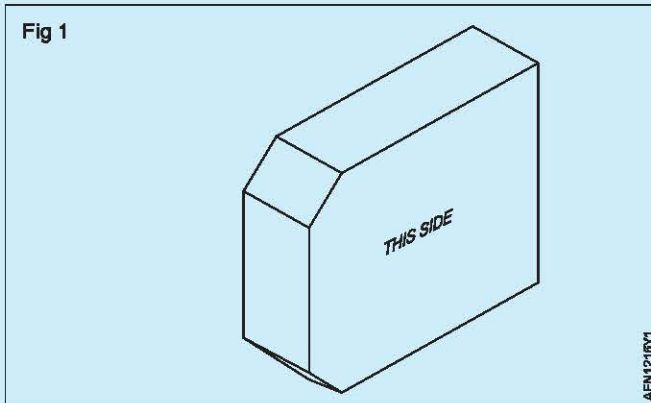

Countersink (Fig 2)

- Hold the workpiece on machine vice.
- Set the countersinking depth by successive tests.
- Check dimension and depth.

TABLE 1

d1	d2	t1
....

Counterboring (Fig 3)

- Hold the workpiece on machine vice.
- Set the counterboring depth by successive tests and check with depth gauge.
- Check dimension and depth.

TABLE 2

d1	d2	t1
....	3mm

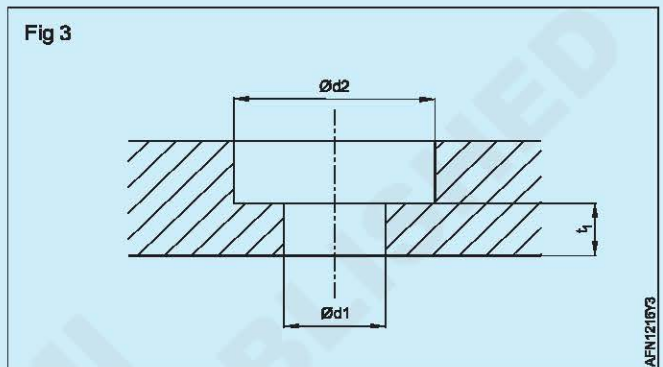
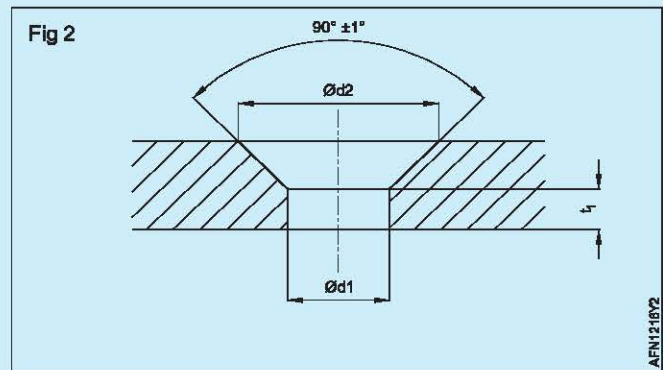

Spot facing (Fig 4)

- Hold the workpiece on machine vice.
- Spot face in a successive pass to obtain a flat surface finishing flush with the chamfer.

TABLE 3

d1	d2
....

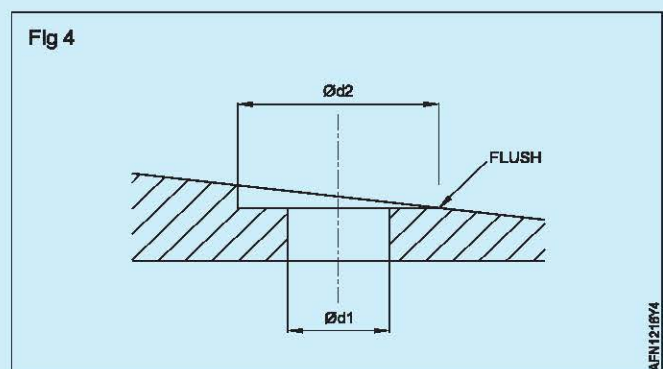

Make internal thread

Objectives: At the end of this exercise you shall be able to

- threading hole
- check internal threads.

The drawing shows a rectangular plate with a total width of 12 units. It features three vertical holes of different diameters: M8, M6, and M4. The holes are spaced evenly across the width. Section A-A is indicated by arrows on the left and right sides of the plate. The section view shows the internal threads of each hole, with the M8 hole having the deepest thread, followed by the M6 hole, and the M4 hole having the shallowest thread. The plate has rounded corners on the right side.

1	-	> 1.2.16D	A2017	-	TASK-1	1.2.16G
NO.OFF	STOCK SIZE	SEMI-PRODUCT	MATERIAL	PROJECT NO.	PART NO.	EX. NO.
SCALE	MAKE INTERNAL THREAD				DEVIATIONS	TIME: 10HRS
					CODE NO: AFN1216E3	

Job Sequence

Tracing and pre-drilling

- Mark the holes positions.
- Punch the centre.
- Hold the workpiece and drill holes to diameter 3.
- Deburr both sides.

Drilling final diameter (Table 1)

- Hold the workpiece on machine vice.
- Drill to the final diameter according to table 1.
- Chamfering both sides.

Threading

- Select the correct taps set.
- Tap the holes.
- Check threading with gauge or bolt.

TABLE 1

Thread	Drilling diameter
M4
M6	
M8	

Skill sequence

Tapping through holes

Objective: This shall help you to
 • **cut internal threads using hand taps.**

Determine the tap drill size either using the formula or the table.

Drill the hole to the required tap drill size.

An undersized hole will lead to breakage of the tap.

Chamfer the end of the drilled hole for easy aligning and starting of the tap. (Fig 1)

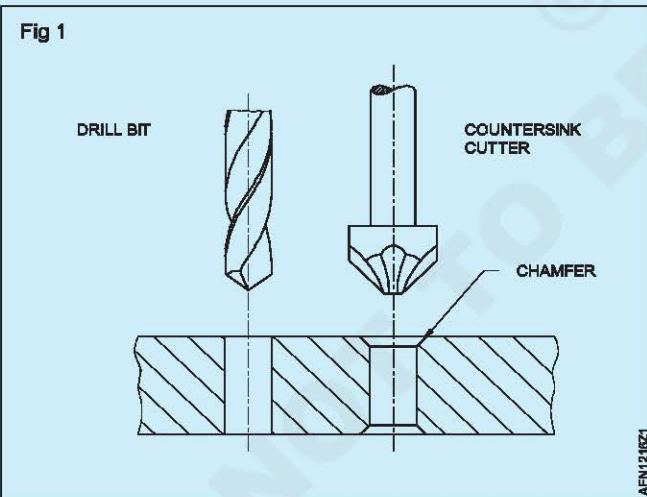

Hold the work firmly and horizontally in the vice. The top surface of the job should be slightly above the level of the vice jaws. This will help in using a square without any obstruction while aligning the tap. (Fig 2)

Fix the first tap (taper tap) in the correct size tap wrench.

Position the tap in the chamfered hole vertically by ensuring the wrench is in a horizontal plane.

Exert steady downward pressure and turn the tap wrench slowly in the clockwise direction to start the thread. Hold the tap wrench close to the centre. (Fig 3)

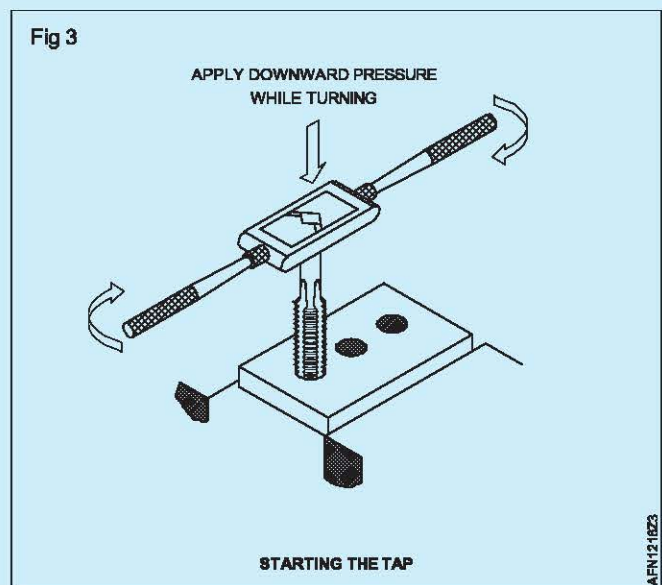
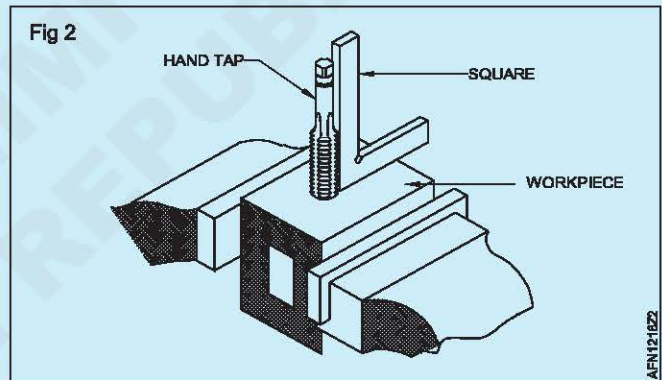

Remove the wrench from the tap when you are sure of starting the thread without disturbing the setting.

Check and make sure that the tap is vertical by using a square in two positions at 90° to each other. (Figs 4)

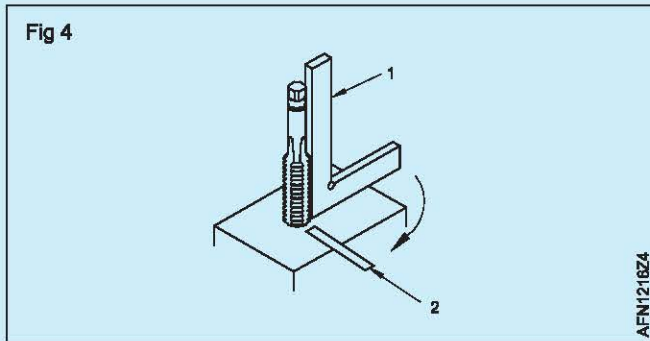

If necessary, make correction by exerting slightly more pressure on the opposite side of the tap inclination.

Check the tap alignment again. The tap alignment should be corrected within the first few turns. If it is tried afterwards there is a possibility of breaking of the tap.

Turn the wrench lightly by holding at the ends without exerting any downward pressure after the tap is positioned vertically. The wrench pressure exerted by the hands should be well balanced. Any extra pressure on one side will spoil the tap alignment and can also cause breakage of the tap. (Fig 5).

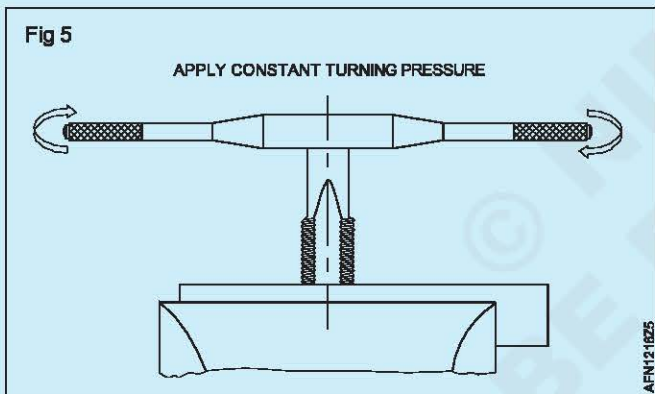

Continue cutting the thread. Turn backwards frequently about quarter turn, to break the chips. (Fig 6)

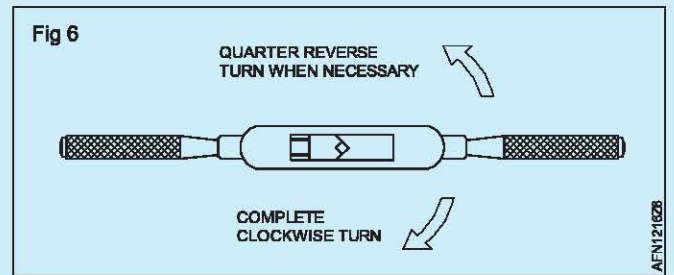

Stop and turn backwards when any obstruction to the movements is felt.

Use a cutting fluid while cutting the thread to minimise friction and heat.

Cut the thread until the hole is totally threaded.

Remove the chips from the work and clean the tap with a brush.

Make sure that the diameter of the hole to be tapped is correct for the given size of the tap.

Turn backwards to break the chip after every quarter turn.

Select the length of wrench suitable to the size of the tap. Overlength of wrench may cause the breakage of tap.

Filing large flat surface and check flatness

Objectives: At the end of this exercise you shall be able to

- file flat with straight file or rasp
- check flatness with straight rule.

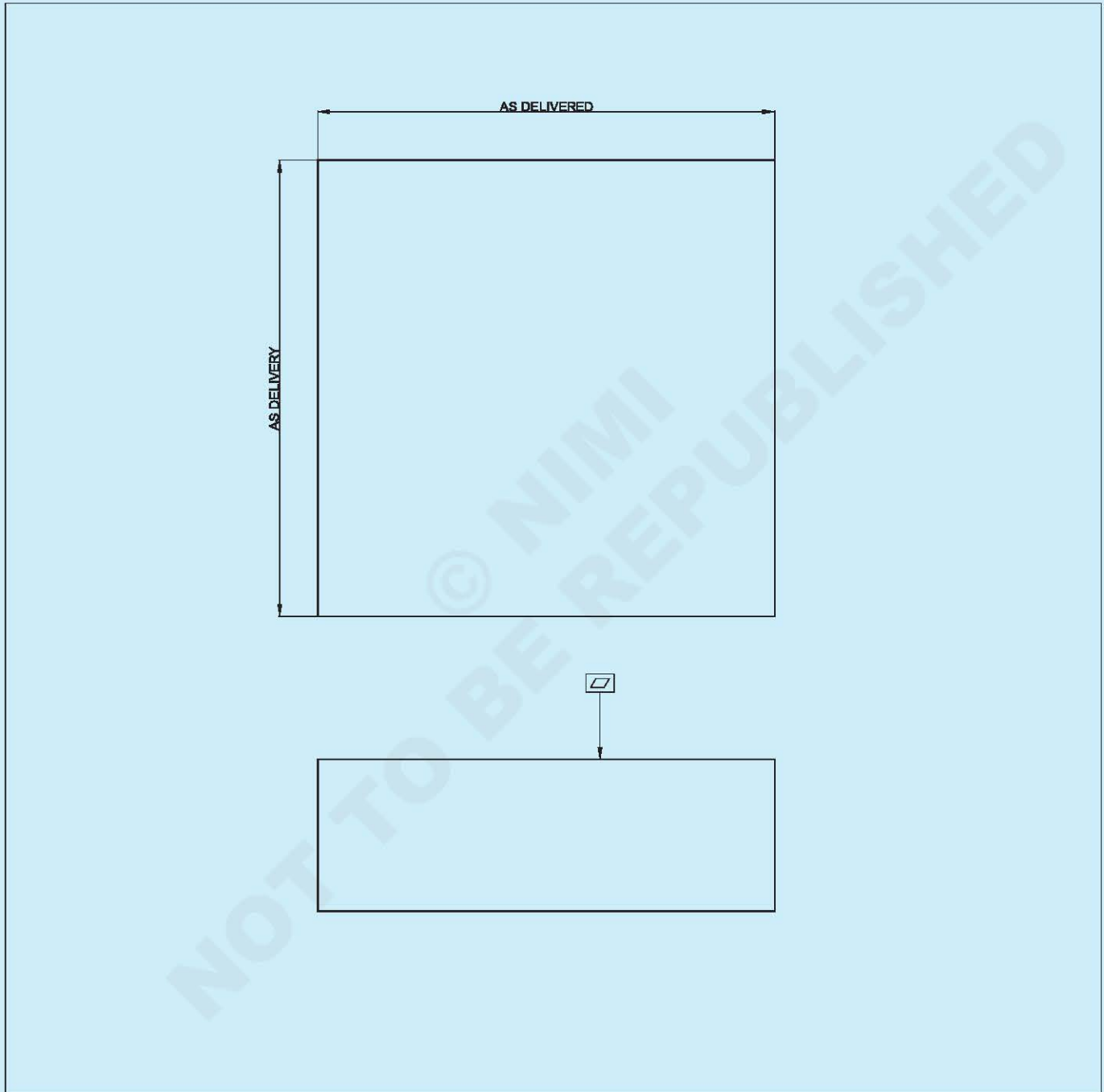

1	60 x 60 x 20	-	A2017	-	TASK-1	1.2.15
NO.OFF	STOCK SIZE	SEMI-PRODUCT	MATERIAL	PROJECT NO.	PART NO.	EX. NO.
SCALE	FILING LARGE FLAT SURFACE AND CHECK FLATNESS				DEVIATIONS	TIME: 5HOURS
					CODE NO: AFN1215E1	

Job Sequence

- Hold the workpiece in the bench vice.
- File with file by crossing filing the surface 'A'.
- Check the flatness regularly.
- Finish the surface by cross filing.
- Deburr edges.

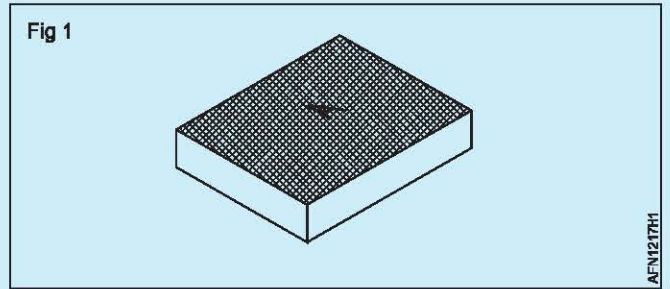

Skill sequence

Clamping the workpiece in the bench vice to filing

Objectives: This shall help you to

- clamp a workpiece firmly in a bench vice
- clamp a workpiece in good position.

Set the correct position of the workpiece

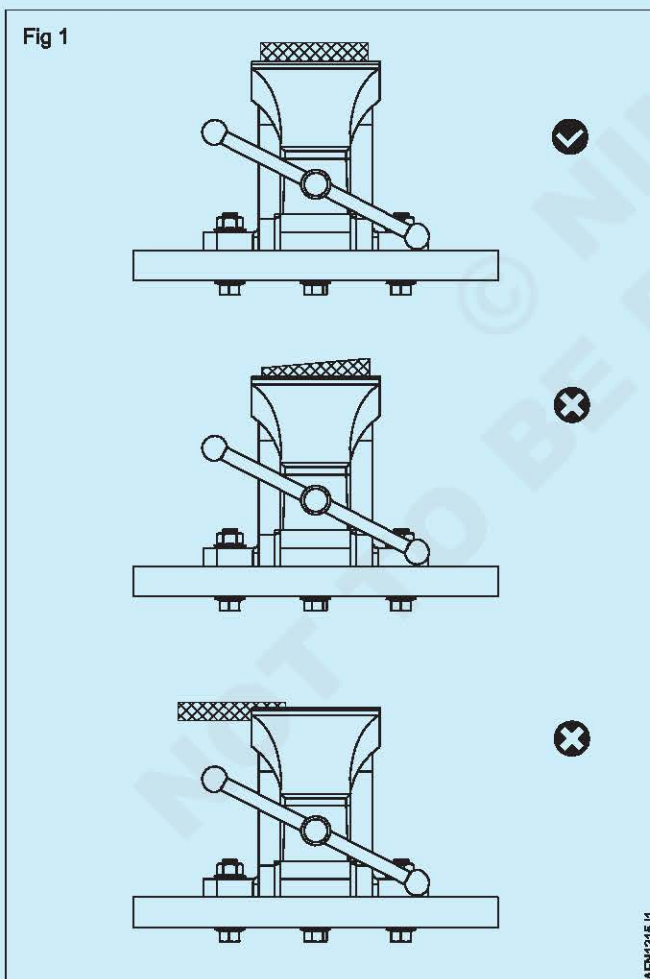

- Hold the workpiece in the bench vice with a minimum projection from the top of the vice jaw without touching the vice.
- The workpiece must be in the centre of the jaws.
- Hold the workpiece parallel to facilitate the flat filing.
- Close the jaws of the bench vice to tighten the workpiece lightly by turning the handle in clockwise direction.

Filing flat

Objective: This shall help you to

- file flat.

Check whether the handle of the file fits tightly. Hold the handle of the file (Fig 1) and push the file forward using your right hand palm on left hand palm.

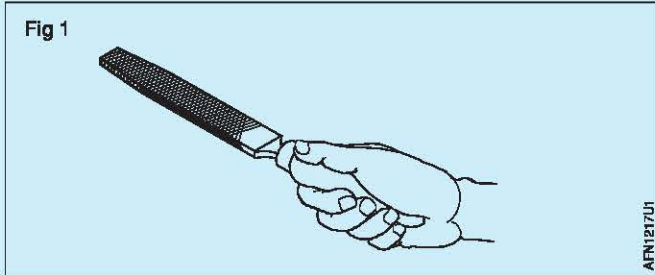

Hold the tip of the file according to the quantity of the metal to be removed.

Start filing by pushing the file uniformly during the forward stroke and release the pressure during the return stroke.

Continue giving strokes. Balance the pressure of the file in such a way that the file always remains flat and straight over the surface to be filed.

For heavy filing. (Fig 2)

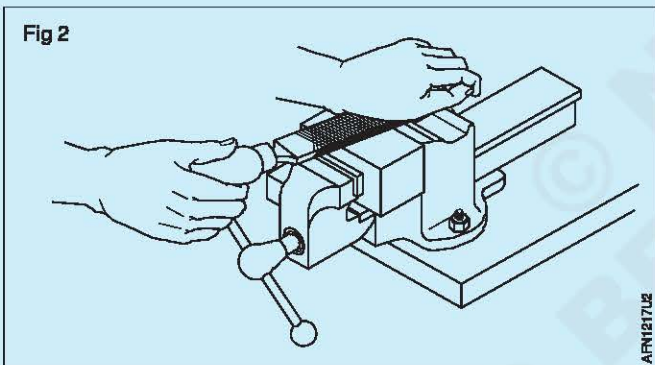

Cross filing

Objective: This shall help you to

- file by cross filing.

In this method of filing, the file is run across the workpiece, which is from left to right or right to left. Thus, filing is done diagonally.

In this method, curves in work pieces can be minimized. Maximum material can be removed due to the cross marks of files. The whole surface of job is covered in a stroke. (Fig 1)

File all the surface with an angle of 45° approximately.

Change the angle of the file and file all the surface. (Fig 2).

For light filing. (Fig 3)

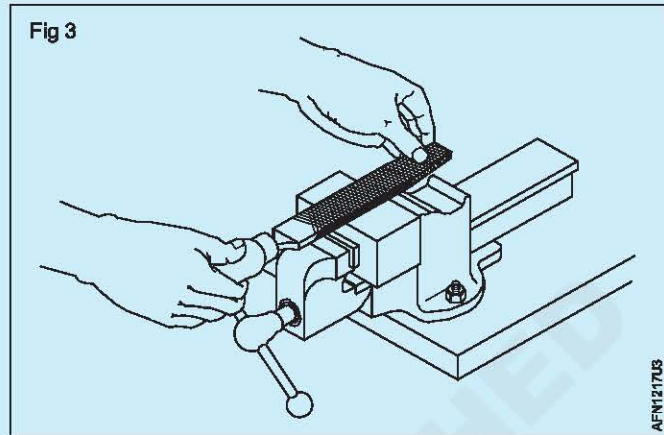

For removing local unevenness. (Fig 4)

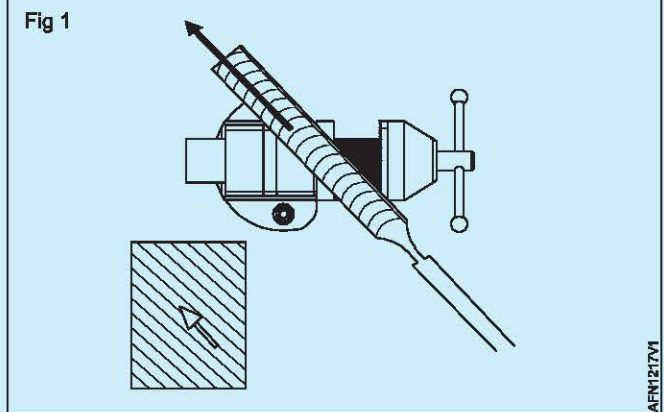
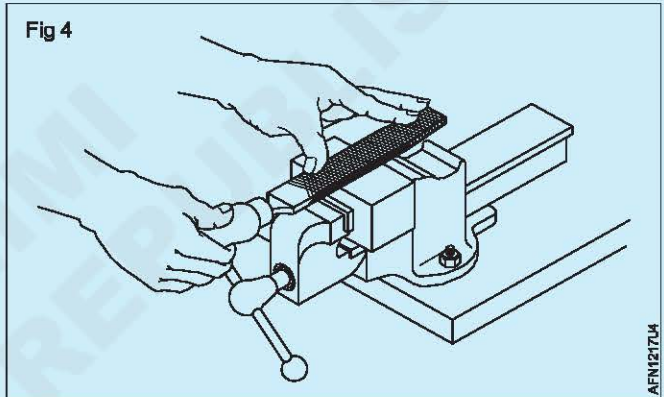

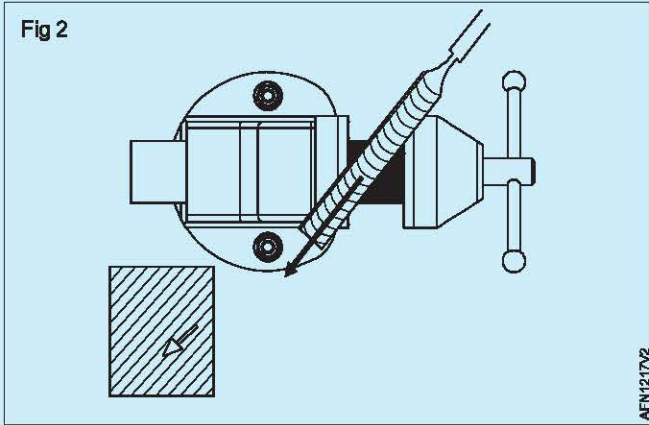

Check flatness with bevelled straight edge

Objective: This shall help you to

- check flatness of a surface.

During filing, the surface can be visually observed to a reasonable degree of perfection. To ensure perfection, the surface should be checked with a beveled straight edge.

Put the straight edge in different areas on the surface in different angles. (Fig 1 and 2)

Do not slide the straight edge against the workpiece to avoid damaging the tool.

Note: the blade of a square can serve as a straight edge.

Burrs should be removed before any checking.

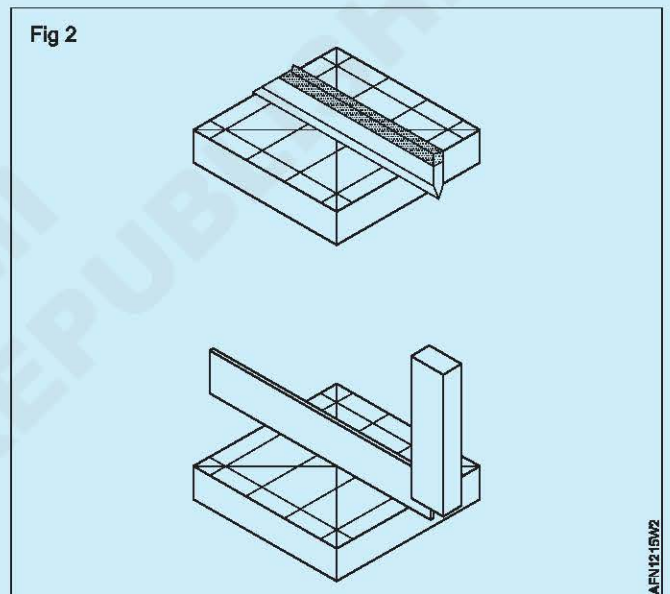
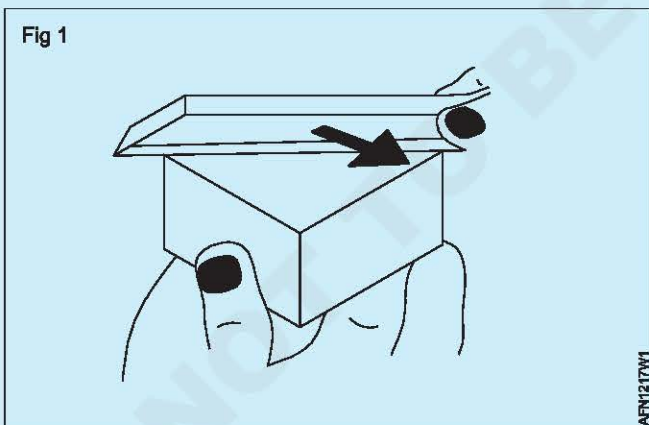

Filing square and check using engineer square

Objectives: At the end of this exercise you shall be able to

- file flat and square with straight file or rasp
- check the squareness with engineer square.

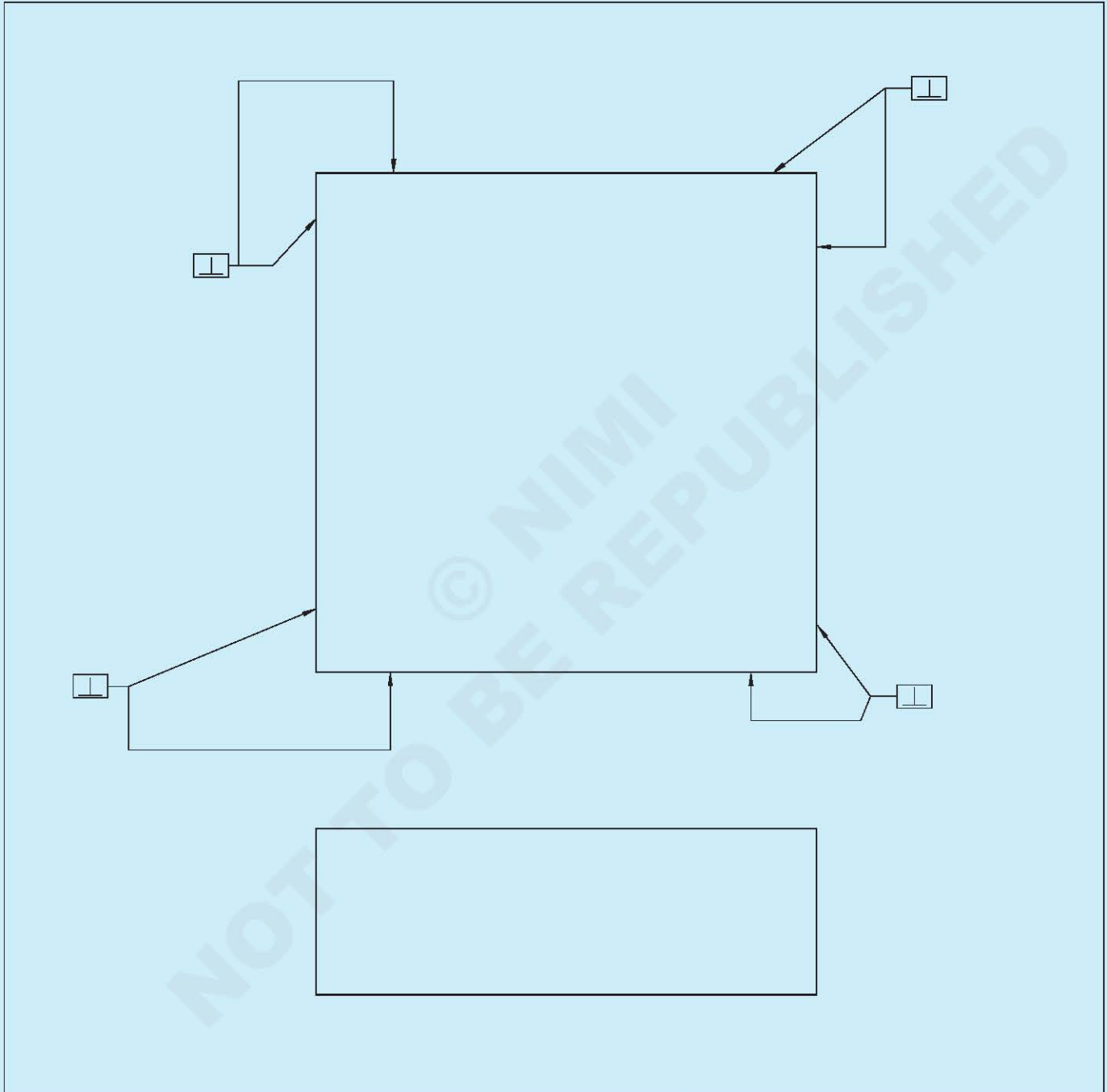

1	60 x 60 x 20	-	A2017	--	TASK-1	1.2.17B
NO.OFF	STOCK SIZE	SEMI-PRODUCT	MATERIAL	PROJECT NO.	PART NO.	EX. NO.
SCALE	FILING SQUARE AND CHECK SQUARENESS				DEVIATIONS	TIME: 5 HOURS
					CODE NO: AFN1217E2	

Job Sequence

- Hold the workpiece in the bench vice.
- File flat and straight the surface 'A'.
- Check the flatness and squareness.
- File flat and straight the surface 'B'.
- Check the squareness with the surface 'A'.
- File flat and straight the surface 'C'.
- Check the squareness with the surface 'B'.
- File flat and straight the surface 'D'.
- Check the squareness with the surfaces 'A and 'C'.

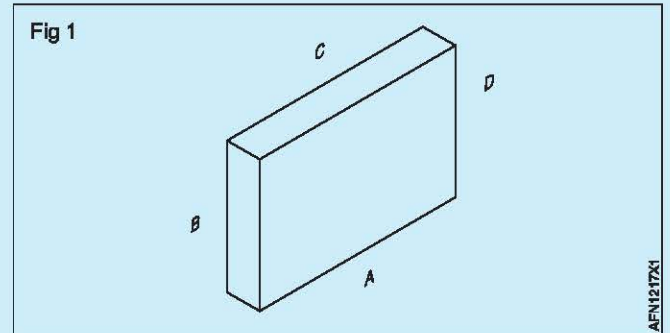

- Finish the four surfaces by draw filing.
- Deburr edges.

Skill sequence

Draw filing

Objective: This shall help you to

- **file by draw filing.**

In this method of filing, files are handled by both hands on the file.

File is placed at right angle to the surface of work piece. (Fig 1)

This method doesn't remove material faster but gives better finish than straight or cross filing.

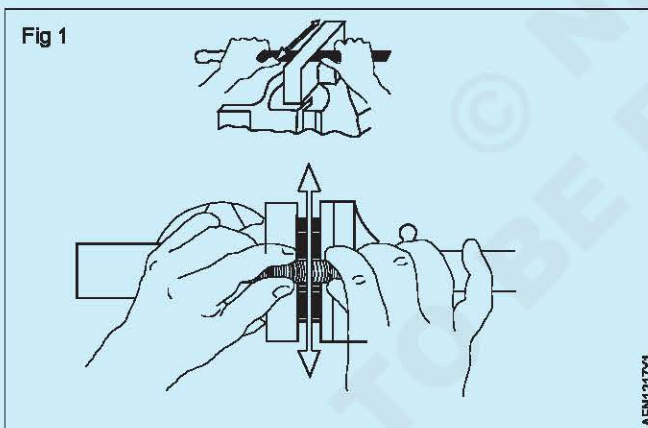

Check squareness with engineer square

Objective: This shall help you to

- **check squareness of an angle.**

To ensure perfection, the squareness should be checked with a square.

Light gap will indicate the high and low spots.

First method: using the square only

While checking with a square, press the stock against the reference and then slowly bring down the blade. (Fig 1)

Second method: using the square on the surface plate

Put the part on the surface plate and one face on the vee block (or an angle plate) to hold the workpiece in position as shown in Fig 2.

Check with a square.

Burrs should be removed before checking.

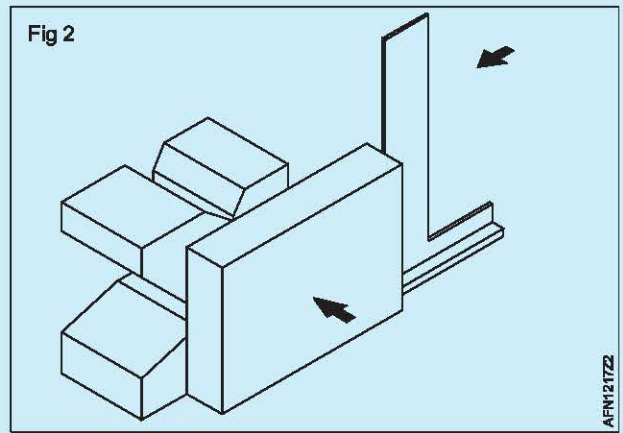
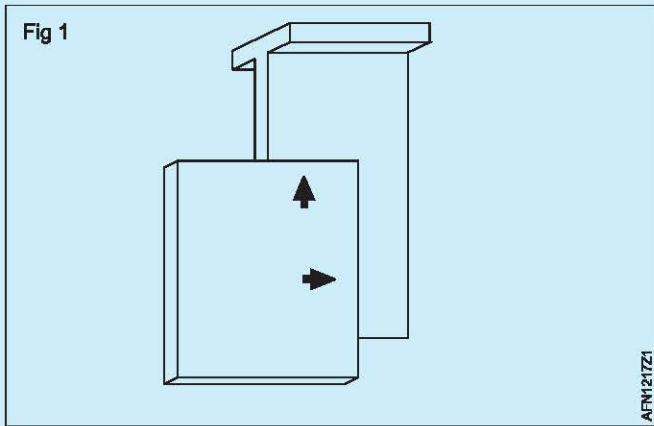

© NIMI
NOT TO BE REPUBLISHED

Ream holes with hand reamer

Objectives: At the end of this exercise you shall be able to

- hand reaming
- check reamed hole with go-no go gauge.

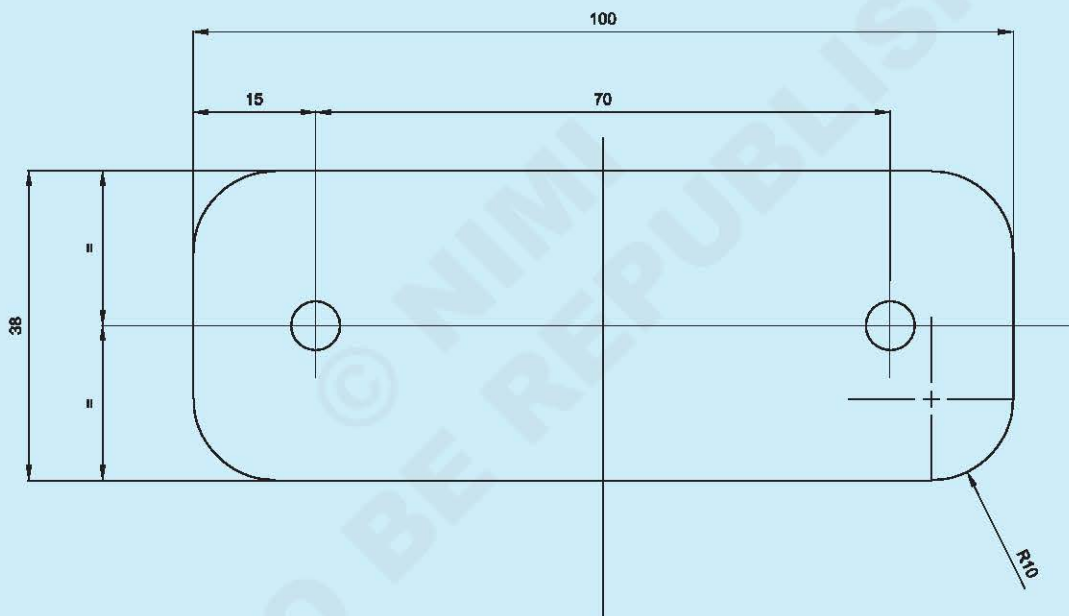

1	40X100 – 2 mm		A7075	-	TASK-1	1.2.18
1	40X100 – 2 mm		STAINLESS STEEL	-	TASK-2	1.2.18
1	40X100 – 5 mm		A2017	-	TASK-3	1.2.18
1	40X100 – 5 mm		STEEL	-	TASK-4	1.2.18
NO.OFF	STOCK SIZE	SEMI-PRODUCT	MATERIAL	PROJECT NO.	PART NO.	EX. NO.

SCALE	REAM HOLES WITH HAND REAMER	DEVIATIONS	TIME: 15HRS
		CODE NO: AFN1218E1	

PROCEDURE

TASK 1: Aluminium 7075

- 1 Check dimensions and thickness.
- 2 Mark and file external dimension and radii.
- 3 Mark the holes positions.
- 4 Punch the centre.
- 5 Hold the workpiece and drill holes.
- 6 Determine the diameter before reaming.
- 7 Deburr both sides.
- 8 Ream the holes.
- 9 Check diameter.

TASK 2: Stainless steel

- 1 Check dimensions and thickness.
- 2 Mark and file external dimension and radii.
- 3 Mark the holes positions.
- 4 Punch the centre.
- 5 Hold the workpiece and drill holes.
- 6 Determine the diameter before reaming.
- 7 Deburr both sides.
- 8 Ream the holes.
- 9 Check diameter.

TASK 3: Aluminium 2017

- 1 Check dimensions and thickness.
- 2 Mark and file external dimension and radii.
- 3 Mark the holes positions.
- 4 Punch the centre.
- 5 Hold the workpiece and drill holes.
- 6 Determine the diameter before reaming.
- 7 Deburr both sides.
- 8 Ream the holes.
- 9 Check diameter.

TASK 4: Steel

- 1 Check dimensions and thickness.
- 2 Mark and file external dimension and radii.
- 3 Mark the holes positions.
- 4 Punch the centre.
- 5 Hold the workpiece and drill holes.
- 6 Determine the diameter before reaming.
- 7 Deburr both sides.
- 8 Ream the holes.
- 9 Check diameter.

TABLE 1: General tolerances

External dimensions and radius	± 0.2 mm
Holes positions	± 0.1 mm

TABLE 2: Dimensions and material by task

TASK	MATERIAL	THICKNESS	HOLE DIAMETER
TASK 1	A7075	5 mm	Ø 6 H 8
TASK 2	STAINLESS STEEL	5 mm	Ø 6 H 8
TASK 3	A2017	5 mm	Ø 6 H 8
TASK 4	STEEL	5 mm	Ø 6 H 8

Skill sequence

Reaming drilled holes using hand reamers

Objective: This shall help you to

- ream through holes.

Determining the drill size for reaming

Determine the tap drill size either using the table 1.

TABLE 1
Undersize for reaming

Diameter of ready reamed hole (mm)	Undersize of rough bored hole (mm)
Under 5	0.1 / 0.2
5 to 20	0.2 / 0.3
21 to 50	0.3 / 0.5
Over 50	0.5 / 1.0

Hand reaming

Chamfer the hole ends slightly. This removes burrs, and will also help to align the reamer vertically (Fig 1). Fix the workpiece in the bench vice. Ensure that the workpiece is horizontal.

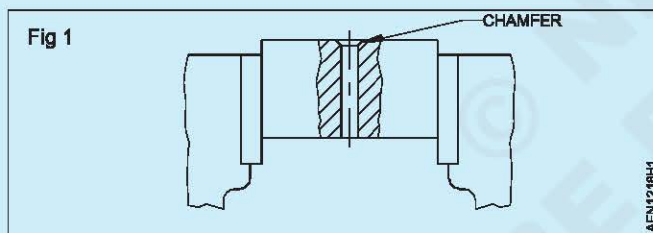

Fix the tap wrench on the square end and place the reamer vertically in the hole. Check the alignment with a square. Make corrections, if necessary. Turn the tap wrench in a clockwise direction applying a slight downward pressure at the same time (Fig 2). Apply pressure evenly at both ends of the tap wrench.

Apply cutting fluid.

Turn the tap wrench steadily and slowly, maintaining the downward pressure.

Do not turn in the reverse direction it will scratch the reamed hole.

Ream the hole through. Ensure that the taper lead length of the reamer comes out well and clear from the bottom of the workpiece. Do not allow the end of the reamer to strike on the vice.

Remove the reamer with an upward pull until the reamer is clear of the hole. (Fig 3)

Remove the burrs from the bottom of the reamed hole.

Clean the hole. Check the accuracy with the go-no go gauge.

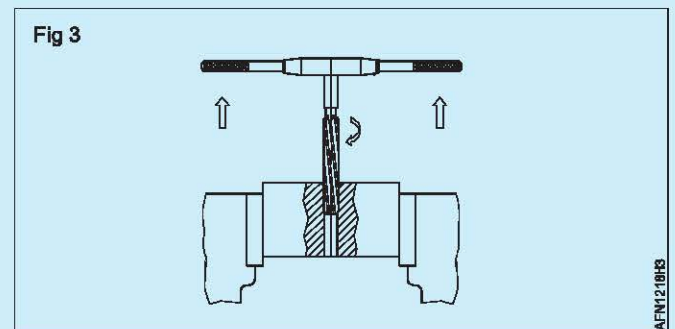
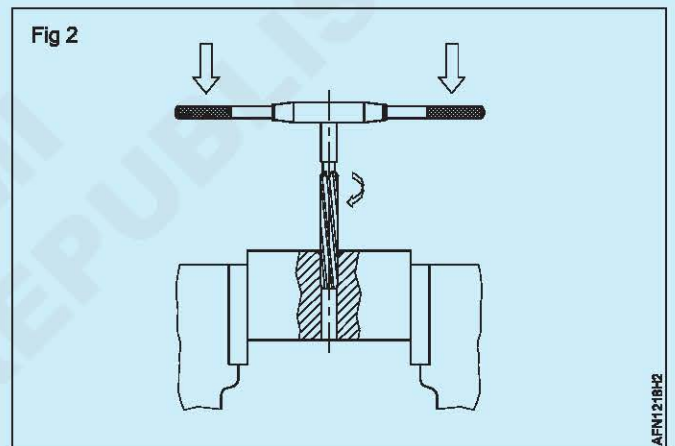

Make components to assembly

Objective: At the end of this exercise you shall be able to
 • file components as per required tolerance.

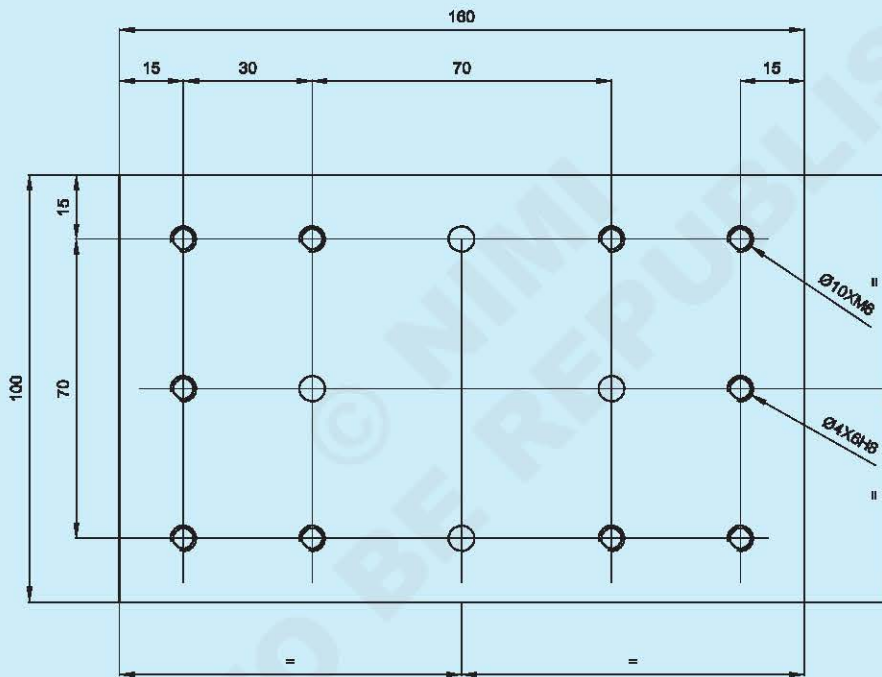

1	100x160 – 10 mm	-	A2024	-	TASK 1	1.2.18
NO.OFF	STOCK SIZE	SEMI-PRODUCT	MATERIAL	PROJECT NO.	PART NO.	EX. NO.
SCALE	MAKE COMPONENTS TO ASSEMBLY				DEVIATIONS	TIME: 12-HRS
					CODE NO: AFN1218E1	

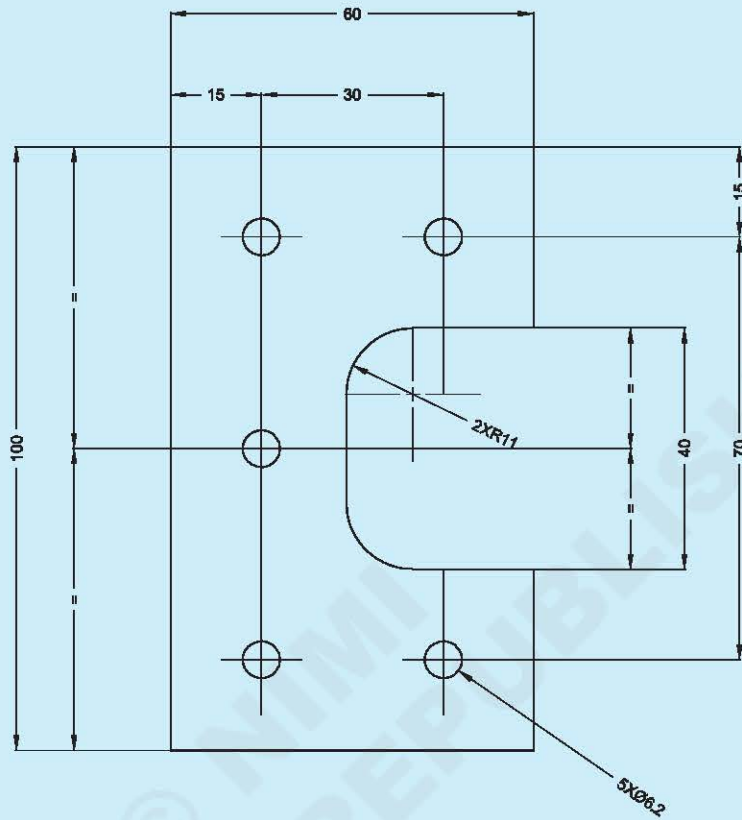

2	100x60 – 5 mm	--	A2024	--	TASK 2	1.2.18B
NO.OFF	STOCK SIZE	SEMI-PRODUCT	MATERIAL	PROJECT NO.	PART NO.	EX. NO.
SCALE NTS		MAKE COMPONENTS TO ASSEMBLY			DEVIATIONS	TIME: 12HRS
					CODE NO: AFN1218E3	

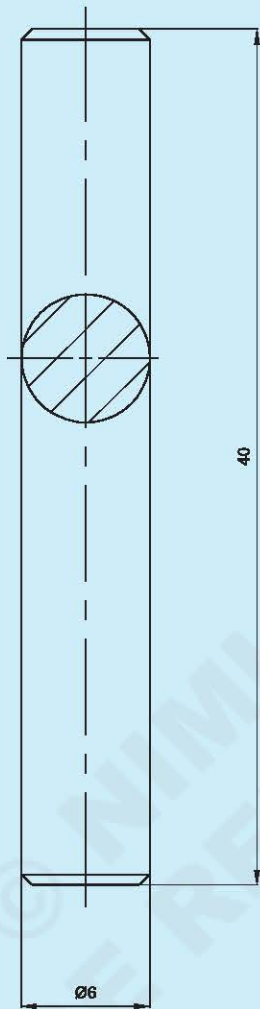

2	ROD Ø 6h10 – 42 mm	--	Constructional steel	--	TASK 3	1.2.18B
NO.OFF	STOCK SIZE	SEMI-PRODUCT	MATERIAL	PROJECT NO.	PART NO.	EX. NO.
SCALE	MAKE COMPONENTS TO ASSEMBLY				DEVIATIONS	TIME: 1HRS
					CODE NO: AFN1218E4	

PROCEDURE

TASK 1: Component 1

- 1 Check dimensions and thickness.
- 2 File external dimensions and finish by draw filing.
- 3 Check flatness, squareness and sizes.
- 4 Mark lines as per drawing and punch on the drill hole using centre punch.
- 5 Hold in drilling machine.
- 6 Determine the drill size for reaming and threading.
- 7 Drill the holes.
- 8 Deburr and chamfer.

9 Ream the 4 holes ($\varnothing 6H8$).

11 Check with go-no go gauge and thread gauge.

10 Thread the 10 hole (M6).

TASK 2: Component 2

1 Check dimensions and thickness.

6 Hold in machine vice and drill.

2 File external dimensions and finish by draw filing.

7 Drill 2 holes to make internal radii.

3 Check flatness, squareness and sizes.

8 Drill 5 holes (diameter 6.2).

4 Mark lines as per drawing and punch on the drill hole using centre punch.

9 Saw internal notch and file.

5 Punch the centre of the holes.

10 Deburr and chamfer.

TASK 3: Component 3

1 Check dimensions.

2 Mark, saw and file external dimension.

3 Deburr by chamfering both tips.

TABLE 1: General tolerances

External dimensions	± 0.2 mm
Notch and radius	± 0.2 mm
Holes positions	± 0.1 mm

TABLE 2: Dimensions and material by task

TASK	MATERIAL	THICKNESS
TASK 1	A2024	10 mm
TASK 2	A2024	5 mm
TASK 3	STEEL	Diameter 6 mm

Make assembly with interchangeability

Objective: At the end of this exercise you shall be able to
 • assemble components with interchangeability.

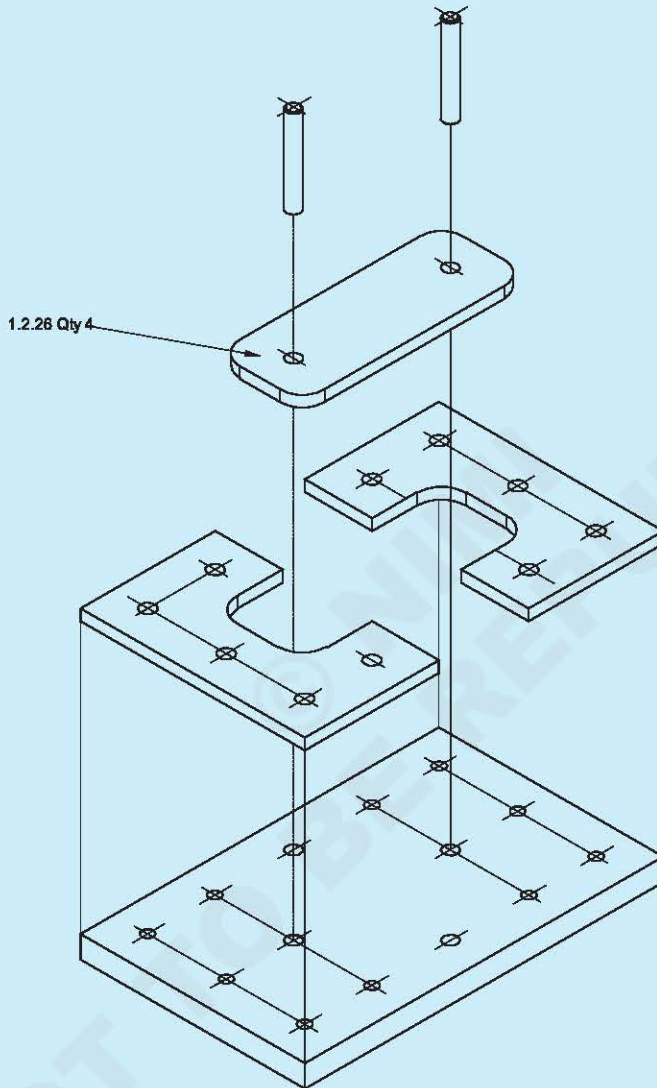

1		> 1.2.18B TASK 1		--		1.2.19
1		> 1.2.18B TASK 2		--		
1		> 1.2.18B TASK 3		--		
1		> 1.2.18A		--		
NO.OFF	STOCK SIZE	SEMI-PRODUCT	MATERIAL	PROJECT NO.	PART NO.	EX. NO.
SCALE		MAKE ASSEMBLY - TASK 1			DEVIATIONS	TIME: 6HOURS
					CODE NO: AFN1219E1	

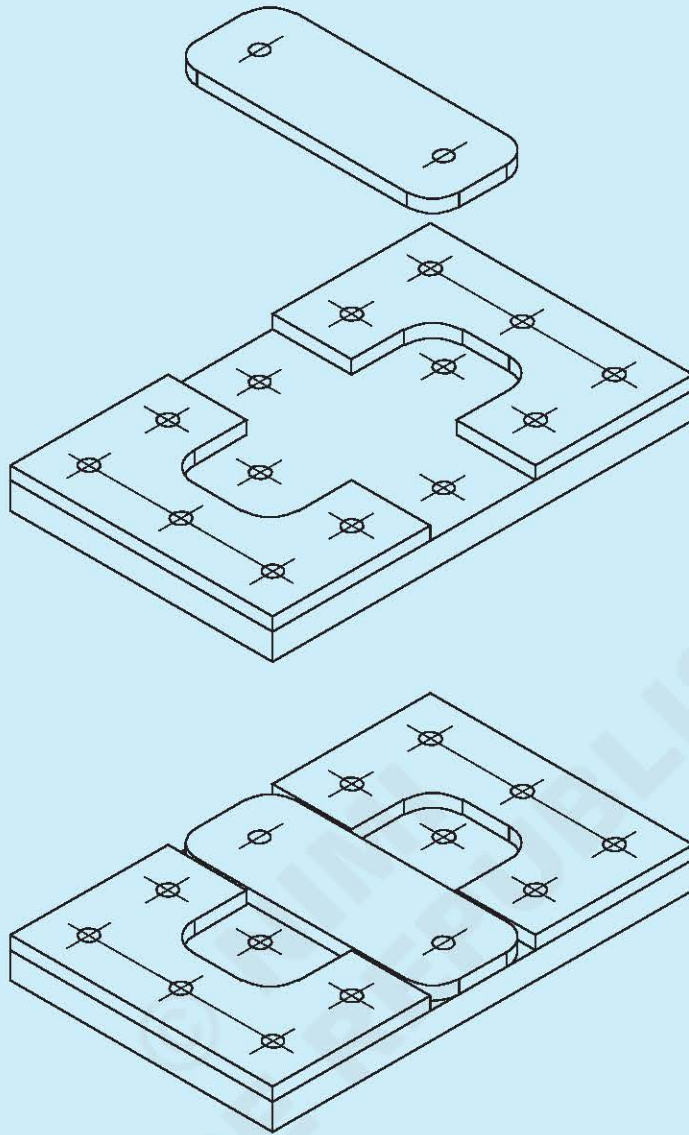

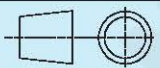
				-		1.2.19
NO.OFF	STOCK SIZE	SEMI-PRODUCT	MATERIAL	PROJECT NO.	PART NO.	EX. NO.
SCALE	MAKE ASSEMBLY - TASK 2 - POSITION 1				DEVIATIONS	TIME: 2HOURS
					CODE NO: AFN1219E2	

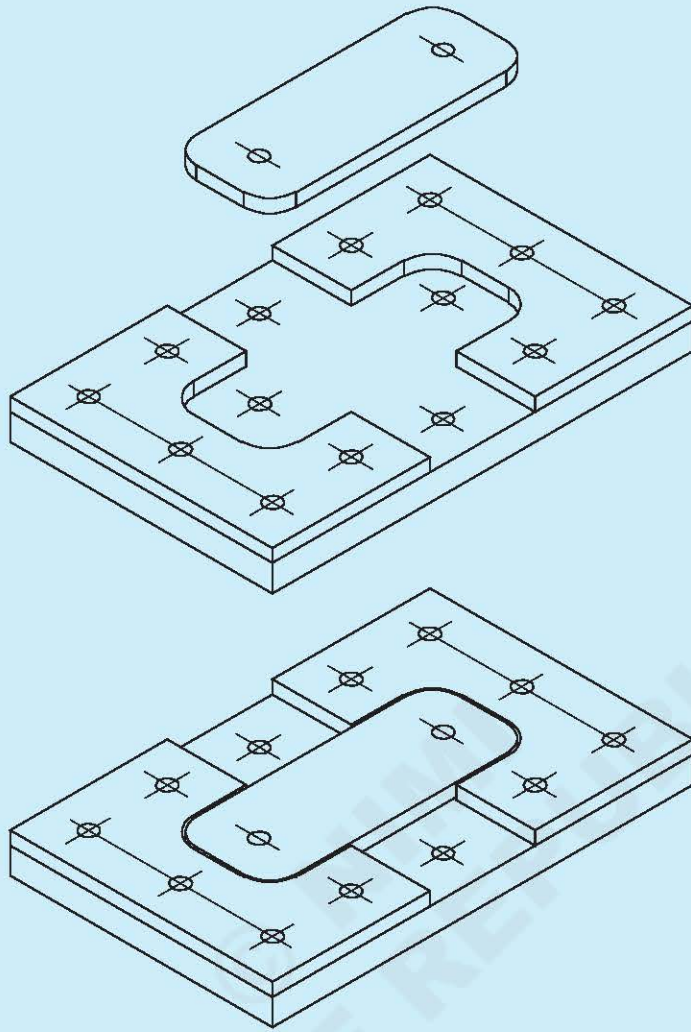

				--		1.2.19
NO.OFF	STOCK SIZE	SEMI-PRODUCT	MATERIAL	PROJECT NO.	PART NO.	EX. NO.
SCALE	MAKE ASSEMBLY - TASK 2 - POSITION 2				DEVIATIONS	TIME: 2HOURS
					CODE NO: AFN1219E3	

PROCEDURE

TASK 1: **Assembling**

- 1 Assemble with hexagonal bolts the 2 parts make in task 2 – exercise 1.2.18B.
- 2 Check assembly.

TASK 2: **Interchangeability**

- 1 Put in position 1 the component A-Exercise 1.2.18B. with pins (see table 1).
- 2 Check position and gap and report on table.
- 3 Make the same work with the other 3 components B, C and D-Exercise 1.2.18B. (see table 1).

TABLE 1

COMPONENT	MATERIAL	POSITION 1		POSITION 2	
		Position	Regular gap	Position	Regular gap
A	A7075	<input type="checkbox"/> OK <input type="checkbox"/> NOK	<input type="checkbox"/> OK <input type="checkbox"/> NOK	<input type="checkbox"/> OK <input type="checkbox"/> NOK	<input type="checkbox"/> OK <input type="checkbox"/> NOK
		NOTES		NOTES	
B	STAINLESS STEEL	<input type="checkbox"/> OK <input type="checkbox"/> NOK	<input type="checkbox"/> OK <input type="checkbox"/> NOK	<input type="checkbox"/> OK <input type="checkbox"/> NOK	<input type="checkbox"/> OK <input type="checkbox"/> NOK
		NOTES		NOTES	
C	A2017	<input type="checkbox"/> OK <input type="checkbox"/> NOK	<input type="checkbox"/> OK <input type="checkbox"/> NOK	<input type="checkbox"/> OK <input type="checkbox"/> NOK	<input type="checkbox"/> OK <input type="checkbox"/> NOK
		NOTES		NOTES	
D	STEEL	<input type="checkbox"/> OK <input type="checkbox"/> NOK	<input type="checkbox"/> OK <input type="checkbox"/> NOK	<input type="checkbox"/> OK <input type="checkbox"/> NOK	<input type="checkbox"/> OK <input type="checkbox"/> NOK
		NOTES		NOTES	

Tensile test N° 1 - Tensile test specimen

Objectives: At the end of this exercise you shall be able to

- prepare tensile test specimen
- conduct tensile test
- read and interpret the curves.

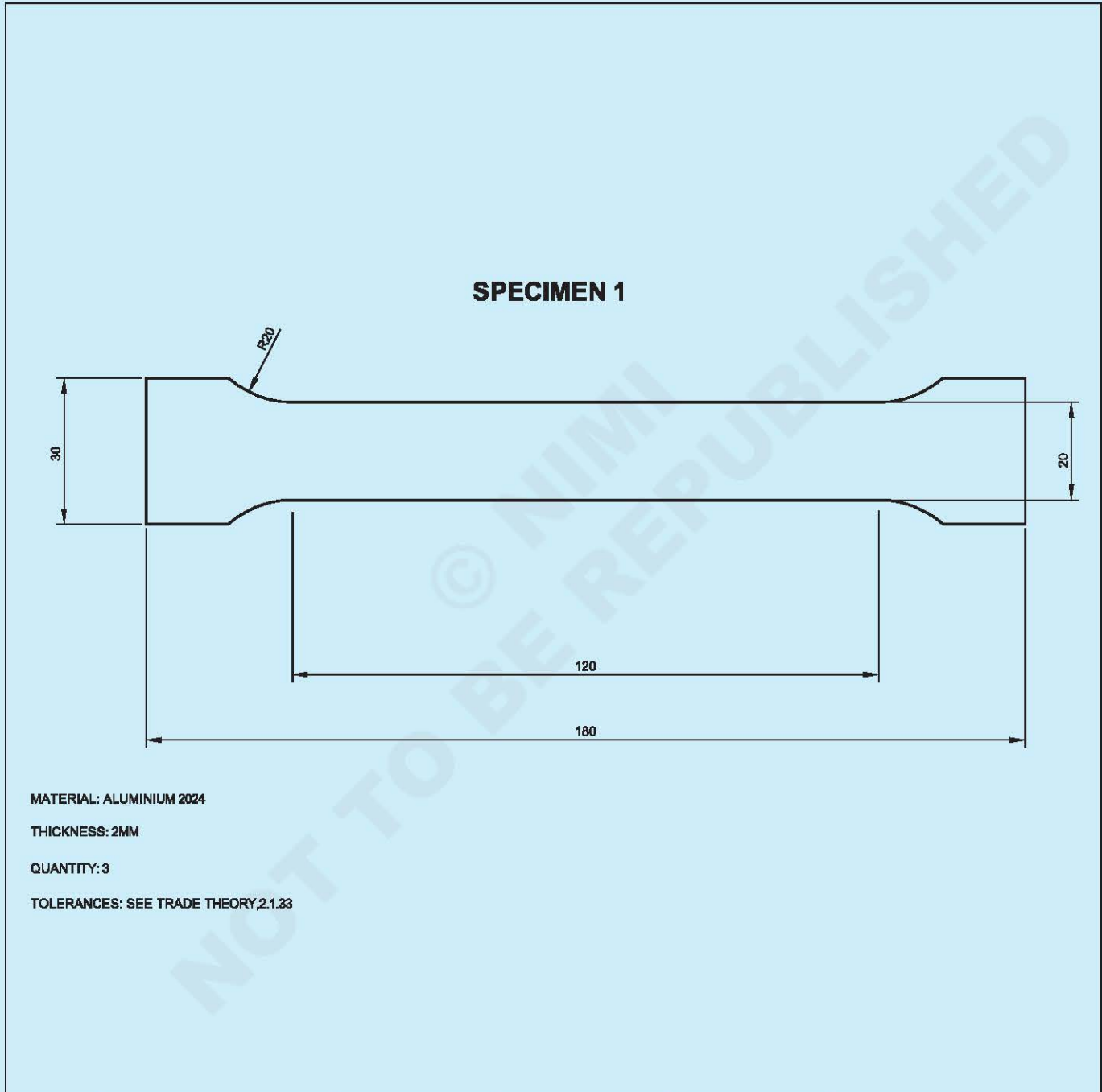

3	35 X 180 - THICK. 2	-	AW-2024	--	-	2.1.20
NO.OFF	STOCK SIZE	SEMI-PRODUCT	MATERIAL	PROJECT NO.	PART NO.	EX. NO.
SCALE: NTS	TENSILE TEST SPECIMENS SPECIMEN 1				DEVIATIONS	TIME: 3HRS
					CODE NO : AFN2120E1	

SPECIMEN 2

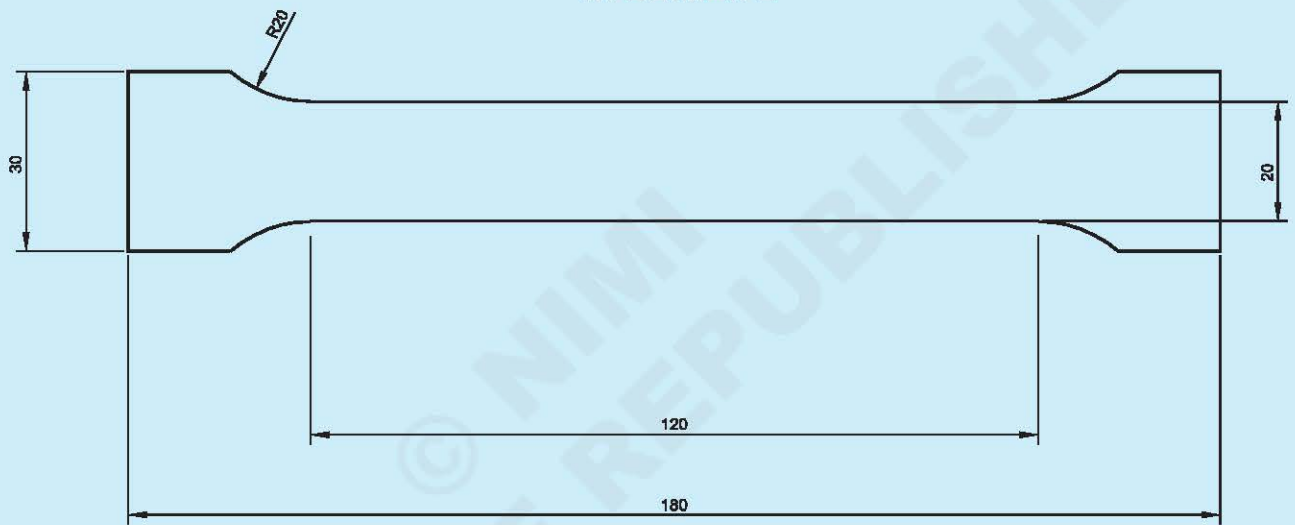

MATERIAL: ALUMINIUM 7075

THICKNESS: 2MM

QUANTITY: 3

TOLERANCES: SEE TRADE THEORY 2.1.33

3	35 X 180 - THICK.. 2	-	AW-7075	-	-	2.1.20	
NO.OFF	STOCK SIZE	SEMI-PRODUCT	MATERIAL	PROJECT NO.	PART NO.	EX. NO.	
SCALE: NTS	TENSILE TEST SPECIMENS SPECIMEN 2				DEVIATIONS	TIME: 3HRS	
						CODE NO : AFN2120E2	

SPECIMEN 3

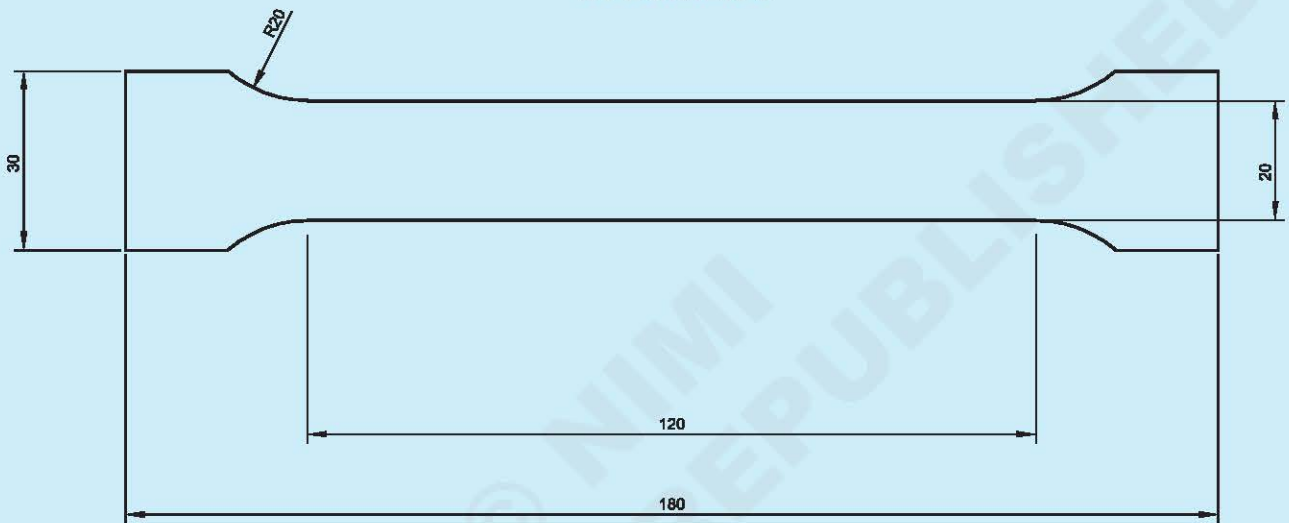

MATERIAL: ALUMINIUM 5056

THICKNESS: 2MM

QUANTITY: 3

TOLERANCES: SEE TRADE THEORY 2.1.33

3	35 X 180 - THICK.. 2	-	AW-5056	-	-	2.1.20
NO.OFF	STOCK SIZE	SEMI-PRODUCT	MATERIAL	PROJECT NO.	PART NO.	EX. NO.
SCALE: NTS		TENSILE TEST SPECIMENS SPECIMEN 3			DEVIATIONS	TIME: 3HRS
					CODE NO : AFN2120E3	

SPECIMEN 4

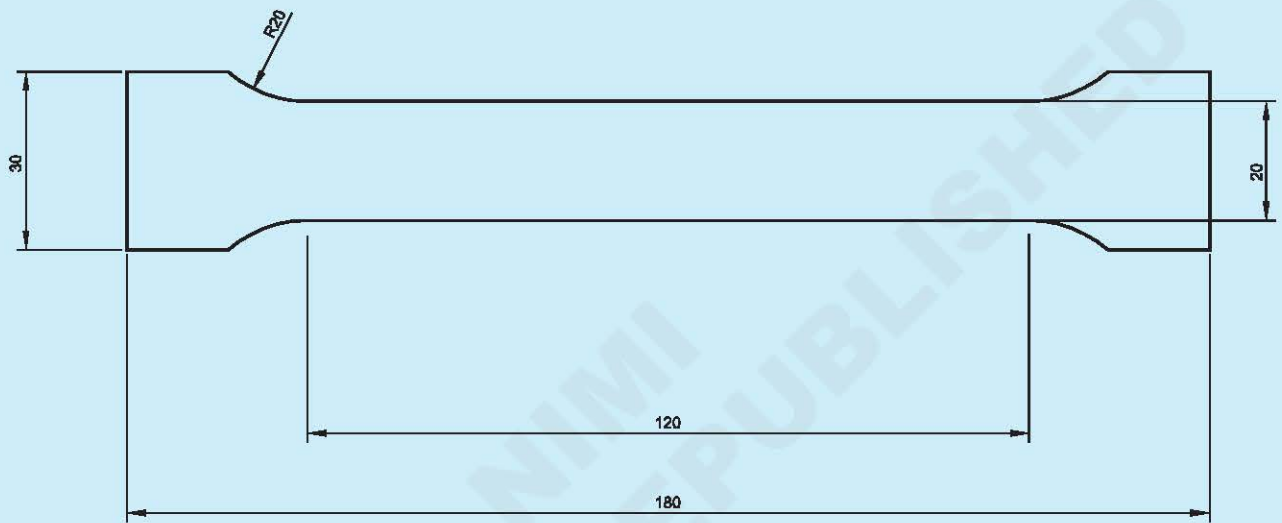

MATERIAL: AISI 316L STAINLESS STEEL

THICKNESS: 2MM

QUANTITY: 3

TOLERANCES: SEE TRADE THEORY 2.1.33

3	35 X 180 - THICK. 2	-	AISI316L	-	-	2.1.20
NO.OFF	STOCK SIZE	SEMI-PRODUCT	MATERIAL	PROJECT NO.	PART NO.	EX. NO.
SCALE: NTS		TENSILE TEST SPECIMENS SPECIMEN 4			DEVIATIONS	TIME: 3HRS
						CODE NO : AFN2120E4

SPECIMEN 5

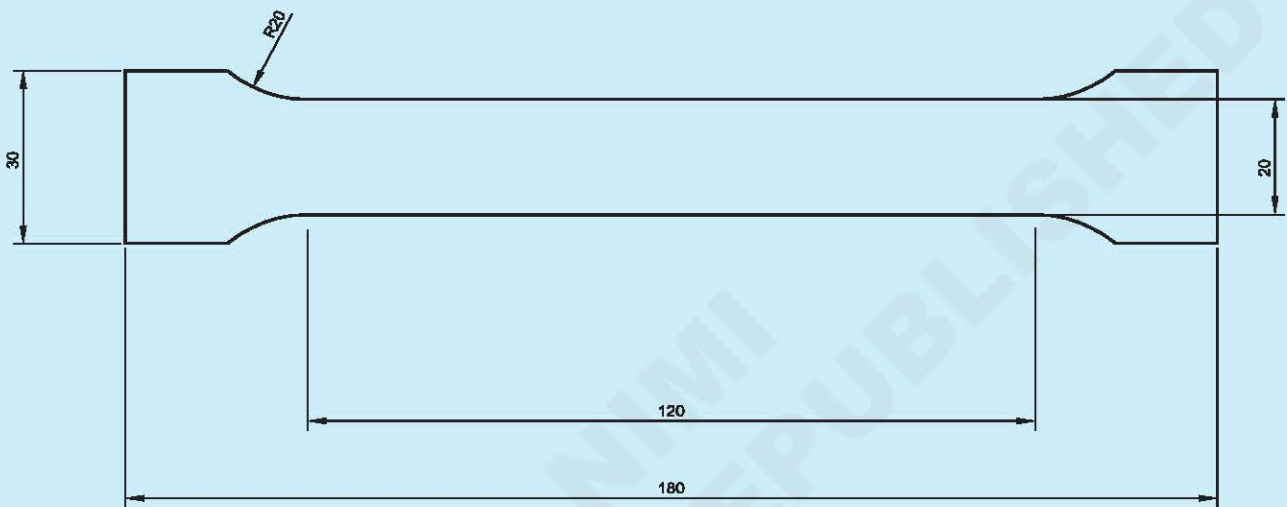

MATERIAL: TITANIUM TA6V

THICKNESS: 2MM

QUANTITY: 3

TOLERANCES: SEE TRADE THEORY, 2.1.33

3	35 X 180 - THICK. 2	TA6V	AW2024	-	-	2.1.20
NO.OFF	STOCK SIZE	SEMI-PRODUCT	MATERIAL	PROJECT NO.	PART NO.	EX. NO.
SCALE: NTS		TENSILE TEST SPECIMENS SPECIMEN 5			DEVIATIONS	TIME: 3HRS
					CODE NO : AFN2120E5	

SPECIMEN 6

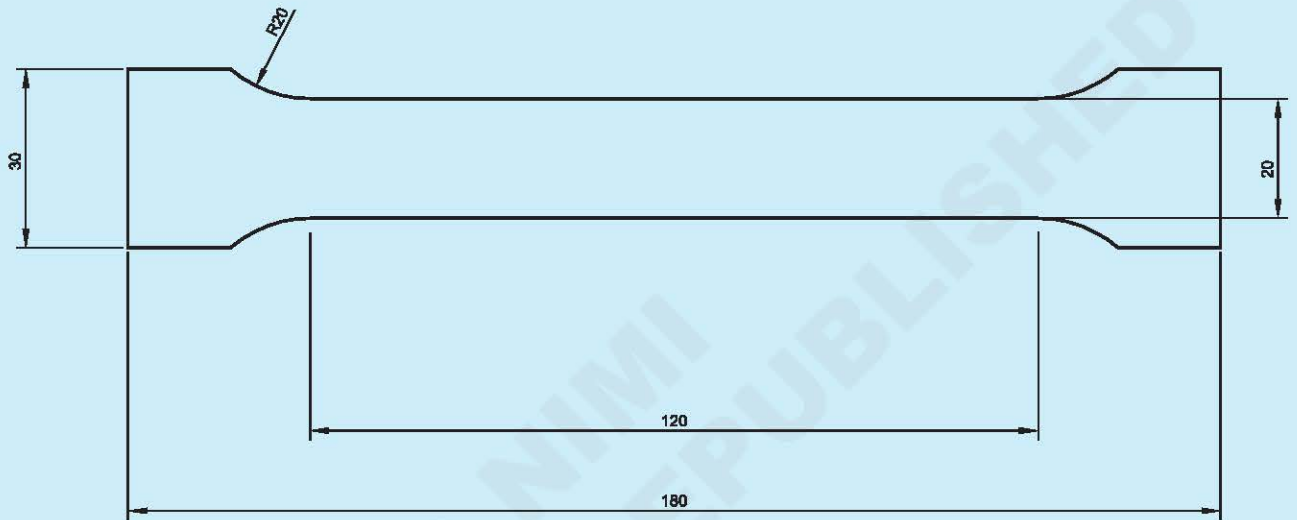

MATERIAL: CARBON STEEL

THICKNESS: 2MM

QUANTITY: 3

TOLERANCES: SEE TRADE THEORY,2.1.33

3	35 X 180 - THICK. 2	--	CARBON STEEL	--	--	2.1.20
NO.OFF	STOCK SIZE	SEMI-PRODUCT	MATERIAL	PROJECT NO.	PART NO.	EX. NO.
SCALE: NTS	TENSILE TEST SPECIMENS SPECIMEN 6				DEVIATIONS	TIME: 3HRS
					CODE NO : AFN2120E6	

PROCEDURE

TASK 1: **Manufacture tensile test specimen**

Specimen 1 – Aluminium 2024

3 specimens

- 1 Check dimensions and thickness.
- 2 Mark external dimensions and radii.
- 3 File the external dimensions and radii.
- 4 Drawn filing all edges.
- 5 Deburr edges.
- 6 Check dimensions.

Specimen N 2 – Aluminium 7075

3 specimens

- 1 Check dimensions and thickness.
- 2 Mark external dimensions and radii.
- 3 File the external dimensions and radii.
- 4 Drawn filing all edges.
- 5 Deburr edges.
- 6 Check dimensions.

Specimen 3 – Aluminium 5056

3 specimens

- 1 Check dimensions and thickness.
- 2 Mark external dimensions and radii.
- 3 File the external dimensions and radii.
- 4 Drawn filing all edges.
- 5 Deburr edges.
- 6 Check dimensions.

Specimens 4 – AISI 316L

3 specimens

- 1 Check dimensions and thickness.
- 2 Mark external dimensions and radii.
- 3 File the external dimensions and radii.
- 4 Drawn filing all edges.
- 5 Deburr edges.
- 6 Check dimensions.

Specimen 5 – TA6V

3 specimens

- 1 Check dimensions and thickness.
- 2 Mark external dimensions and radii.
- 3 File the external dimensions and radii.
- 4 Drawn filing all edges.
- 5 Deburr edges.
- 6 Check dimensions.

Specimens 6 – Carbon steel

3 specimens

- 1 Check dimensions and thickness.
- 2 Mark external dimensions and radii.
- 3 File the external dimensions and radii.
- 4 Drawn filing all edges.
- 5 Deburr edges.
- 6 Check dimensions.

TASK 2: **Make tensile test**

- 1 Perform a tensile test on each specimen.
 - 2 Store the curves produced in each test for later study.
-

Perform manual drilling

Objectives: At the end of this exercise you shall be able to

- mark rows on sheet metal without scratch
- drill with pneumatic hand drill
- deburr holes.

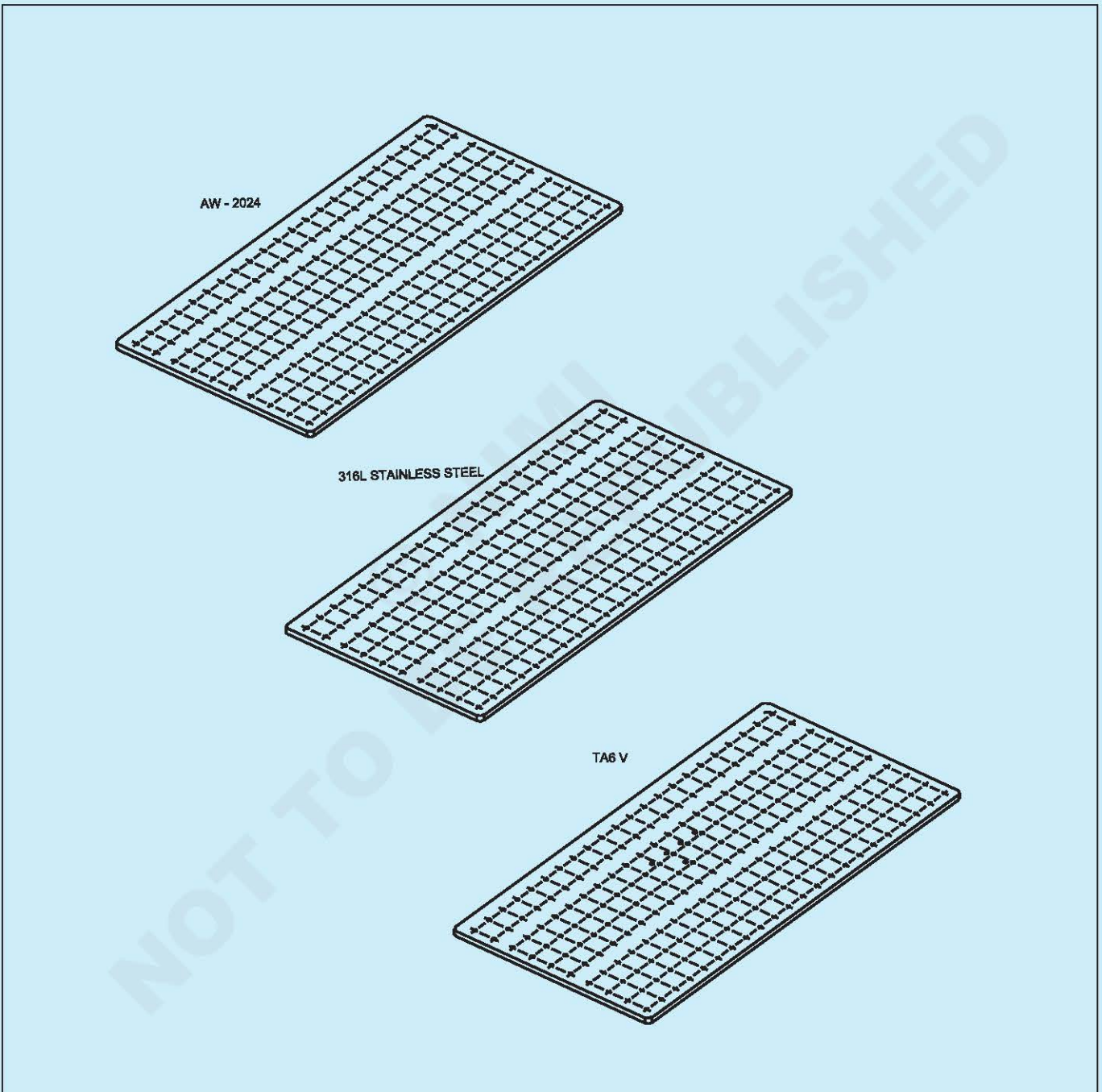

1	-	-	-	-	-	2.1.21
NO.OFF	STOCK SIZE	SEMI-PRODUCT	MATERIAL	PROJECT NO.	PART NO.	EX. NO.
SCALE: NTS	PERFORM MANUAL DRILLING OVERVIEW				DEVIATIONS	TIME:
					CODE NO : AFN2121E1	

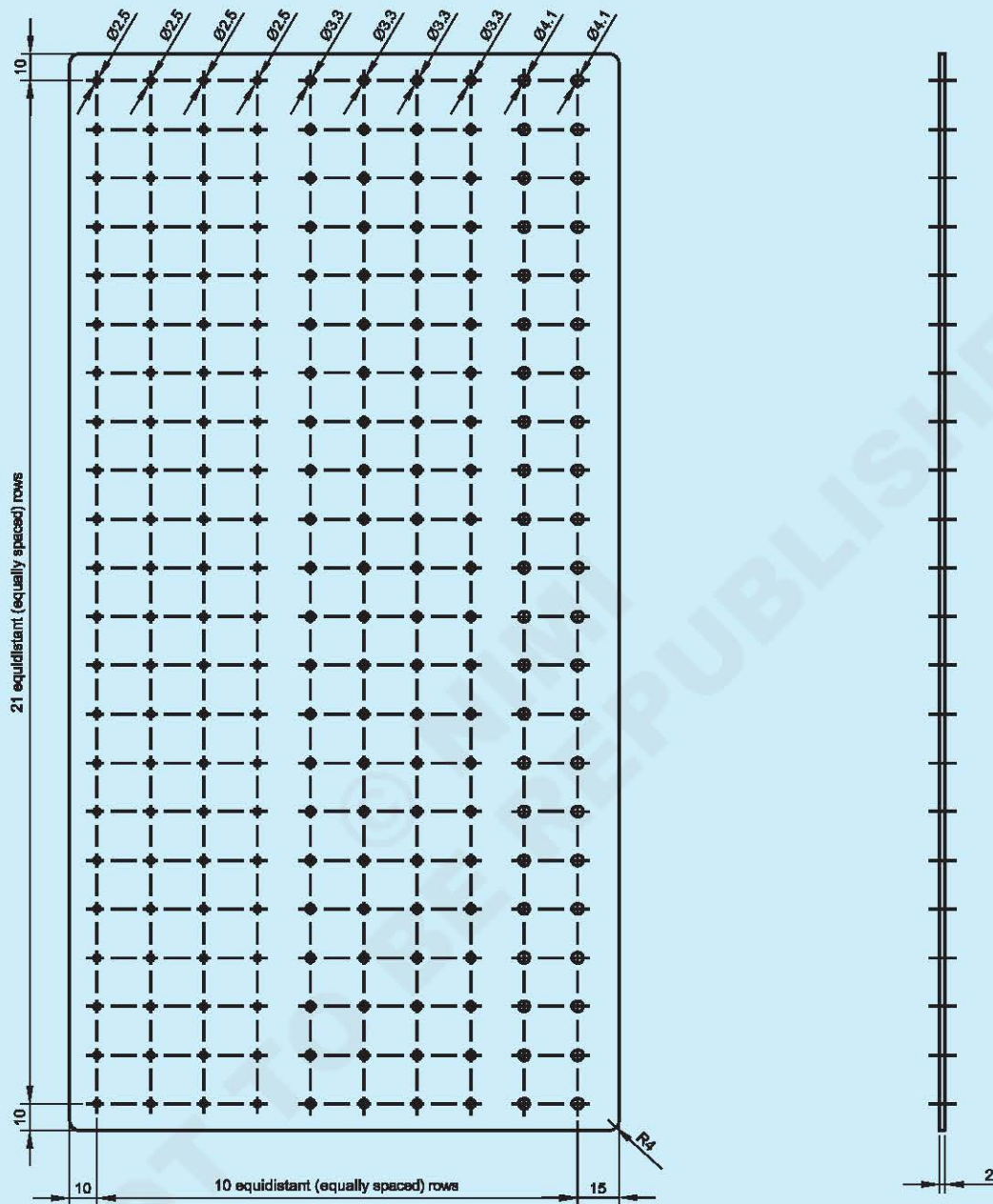

1	200 X 400 - 2 MM	-	316L STEEL	-	--	2.1.21
NO.OFF	STOCK SIZE	SEMI-PRODUCT	MATERIAL	PROJECT NO.	PART NO.	EX. NO.
SCALE: NTS	PERFORM MANUAL DRILLING PIECE 1				DEVIATIONS	TIME: 4HRS
					CODE NO : AFN2121E2	

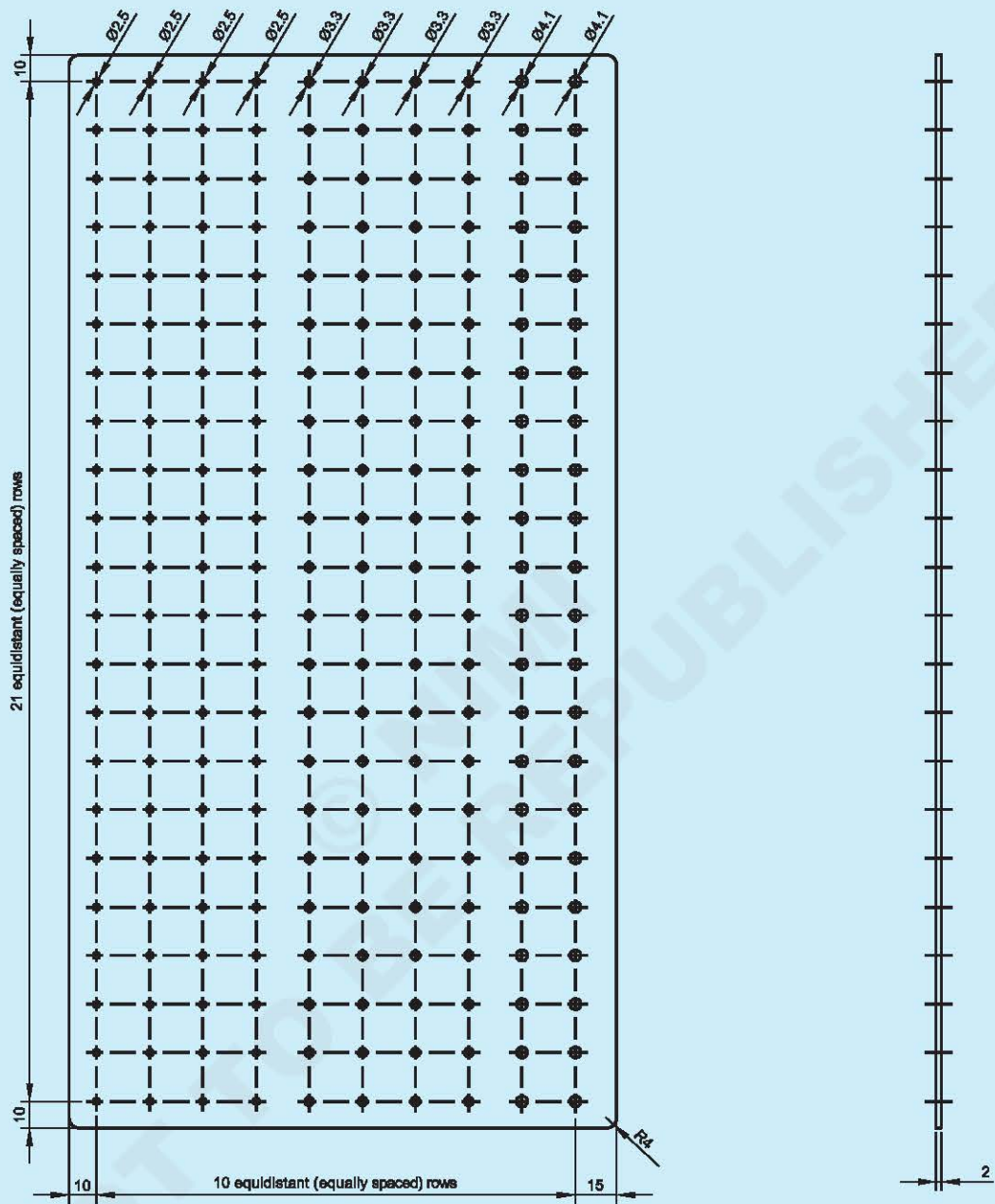

1	200 X 400 - 2 MM	--	AW-2024	--	--	2.1.21
NO.OFF	STOCK SIZE	SEMI-PRODUCT	MATERIAL	PROJECT NO.	PART NO.	EX. NO.
SCALE: NTS	PERFORM MANUAL DRILLING PIECE 2				DEVIATIONS	TIME: 4HRS
					CODE NO : AFN2121E3	

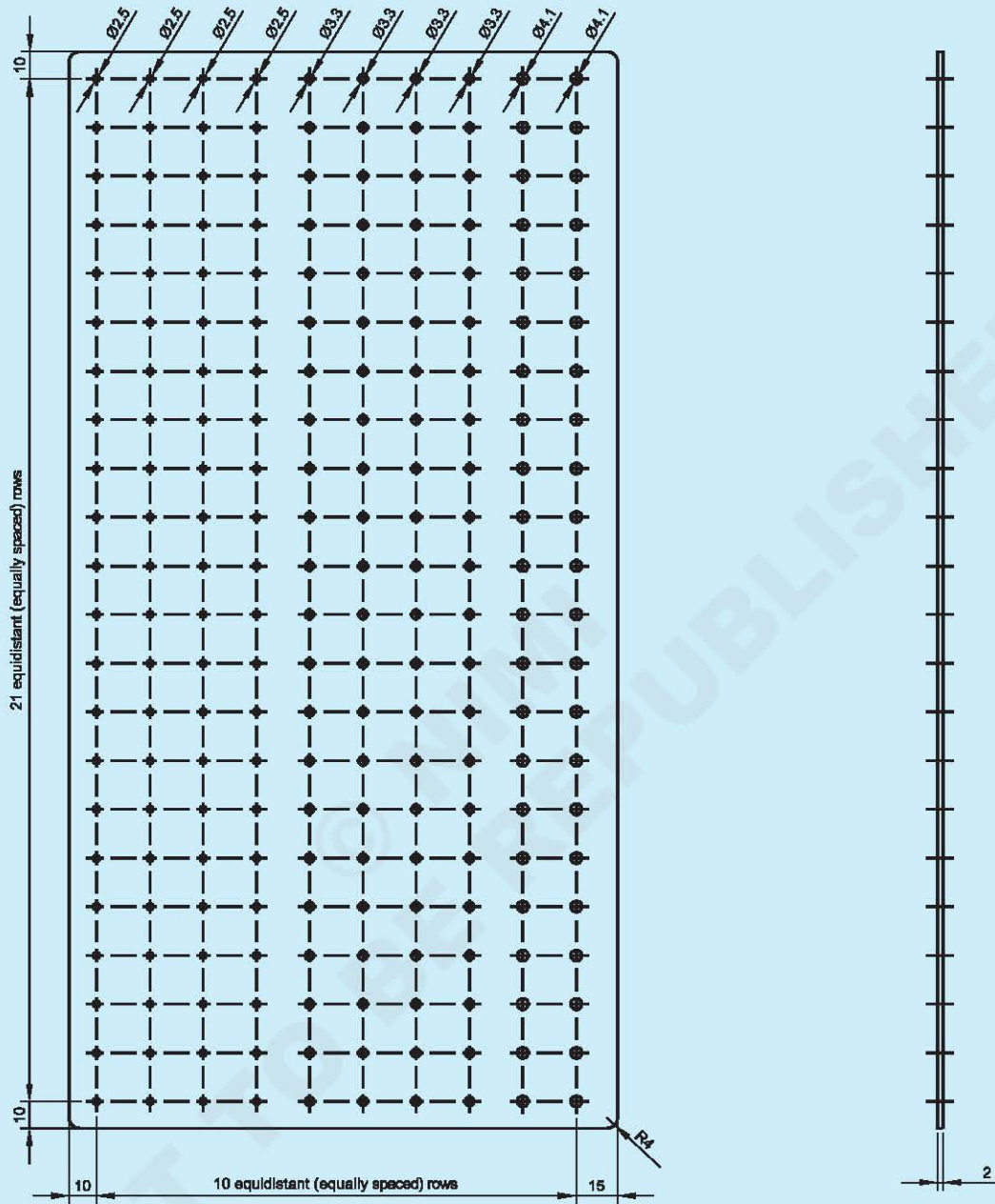

1	200 X 400 - 2 MM	--	TA6V	-	-	2.1.21
NO.OFF	STOCK SIZE	SEMI-PRODUCT	MATERIAL	PROJECT NO.	PART NO.	EX. NO.
SCALE: NTS	PERFORM MANUAL DRILLING PIECE 3				DEVIATIONS	TIME: 3HRS
					CODE NO : AFN2121E4	

PROCEDURE

TASK 1: **Drilling 316L sheet metal**

- 1 Check dimensions and thickness.
- 2 Mark and file external dimension and radii.
- 2 Mark the holes positions.
- 4 Punch the centre.

Drilling diameter 2.5 (all holes)

- 1 Hold the workpiece and drill holes with hand drill.
- 2 Deburr both sides.
- 3 Check diameter and perpendicularity of each hole.

Drilling diameter 3.3 (see drawing)

- 1 Make a circle around each centre to be drilled.

- 2 Hold the workpiece and drill holes with hand drill using drill bushing holder.
- 3 Deburr both sides.
- 4 Check diameter and perpendicularity of each hole.

Drilling diameter 4.1 (see drawing)

- 1 Make a circle around each centre to be drilled.
- 2 Hold the workpiece and drill holes with hand drill using drill bushing holder.
- 3 Deburr both sides.
- 4 Check diameter and perpendicularity of each hole.

Report defects on the report sheet above.

TASK 2: **Drilling AW-2024 sheet metal**

- 1 Check dimensions and thickness.
- 2 Mark and file external dimension and radii.
- 3 Mark the holes positions.
- 4 Punch the centre.

Drilling diameter 2.5 (all holes)

- 1 Hold the workpiece and drill holes with hand drill.
- 2 Deburr both sides.
- 3 Check diameter and perpendicularity of each hole.

Drilling diameter 3.3 (see drawing)

- 1 Make a circle around each centre to be drilled.
- 2 Hold the workpiece and drill holes with hand drill using drill bushing holder.

- 3 Deburr both sides.
- 4 Check diameter and perpendicularity of each hole.

Drilling diameter 4.1 (see drawing)

- 1 Make a circle around each centre to be drilled.
- 2 Hold the workpiece and drill holes with hand drill using drill bushing holder.
- 3 Deburr both sides.
- 4 Check diameter and perpendicularity of each hole.

Report defects on the report sheet above.

TASK 3: **Drilling TA6V sheet metal**

- 1 Check dimensions and thickness.
- 2 Mark and file external dimension and radii.
- 3 Mark the holes positions.
- 4 Punch the centre.

Drilling diameter 2.5 (all holes)

- 1 Hold the workpiece and drill holes with hand drill.
- 2 Deburr both sides.
- 3 Check diameter and perpendicularity of each hole.

Drilling diameter 3.3 (see drawing)

- 1 Make a circle around each centre to be drilled.

- 2 Hold the workpiece and drill holes with hand drill using drill bushing holder.
- 3 Deburr both sides.
- 4 Check diameter and perpendicularity of each hole.

Drilling diameter 4.1 (see drawing)

- 1 Make a circle around each centre to be drilled.
- 2 Hold the workpiece and drill holes with hand drill using drill bushing holder.
- 3 Deburr both sides.
- 4 Check diameter and perpendicularity of each hole.

Report defects on the report sheet above.

Fig 1

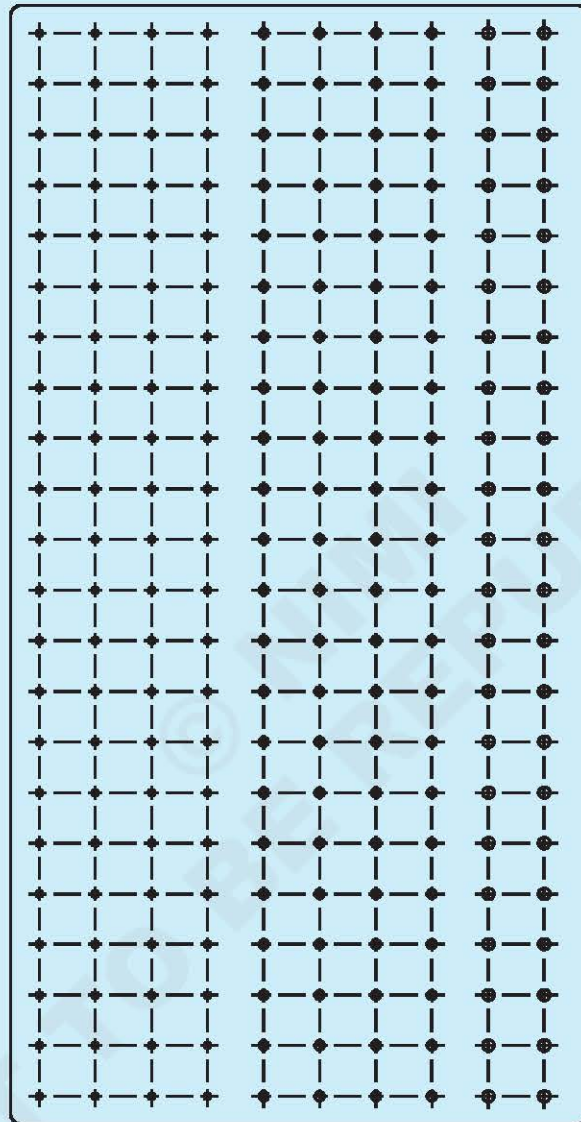

Ø>DIAMETER

P> PERPENDICULAR

C>CIRCULARITY

D>DEBURRING

NC>NOT CENTRED

AFNS121H1

Fig 2

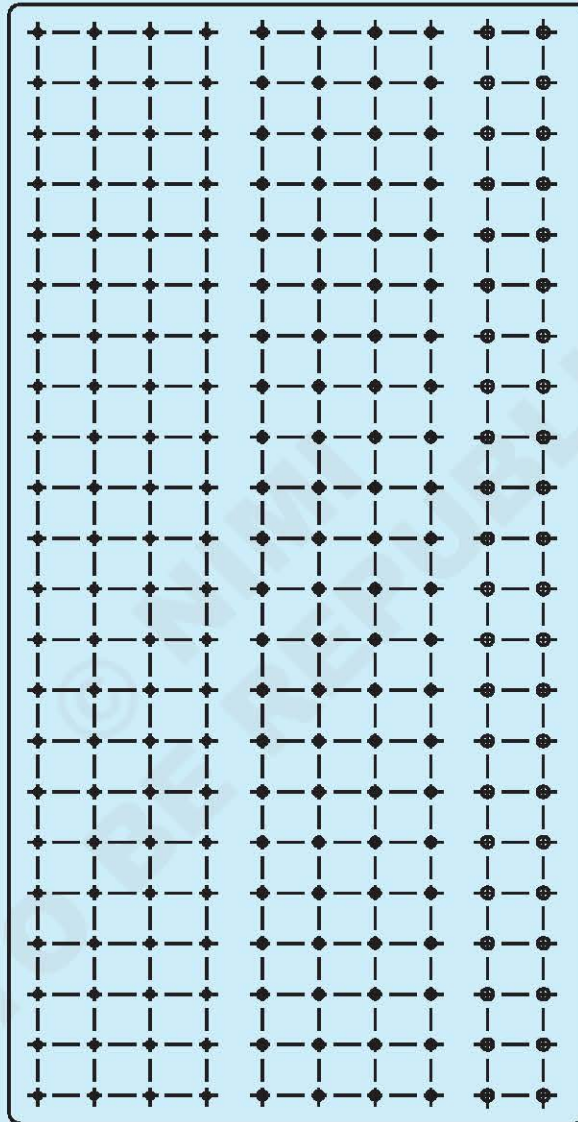

Ø>DIAMETER

P> PERPENDICULAR

C>CIRCULARITY

D>DEBURRING

NC>NOT CENTRED

Fig 3

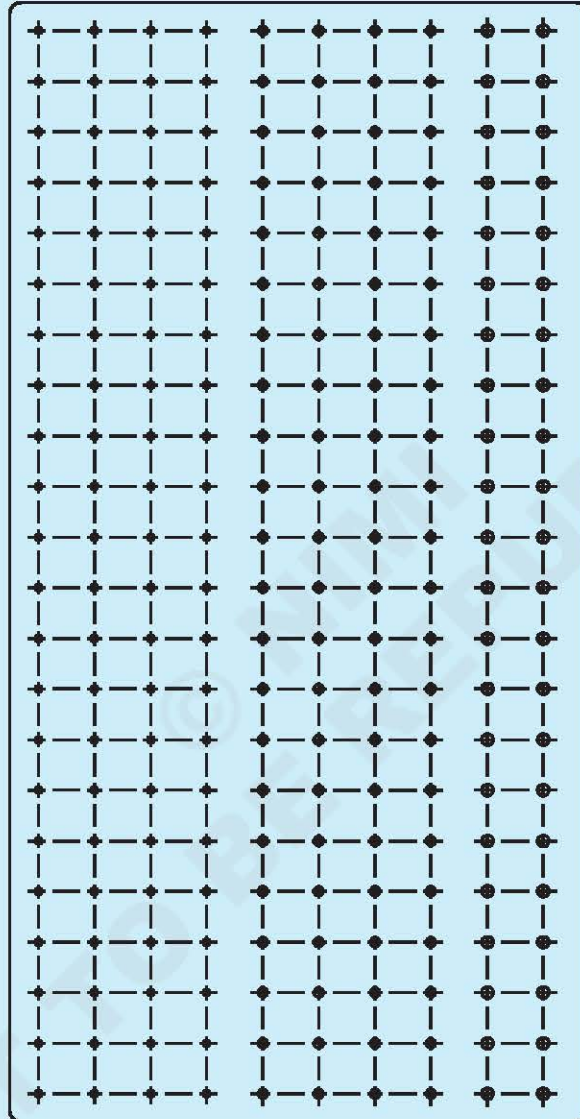

Ø>DIAMETER

P> PERPENDICULAR

⊙>CIRCULARITY

D>DEBURRING

NC>NOT CENTRED

AFN2121H3

Skill Sequence

Drilling hole using pneumatic hand drill

Objective: This shall help you to

- **Drill holes using hand drill.**
-

When using the portable power drill, hold it firmly with both hands.

Before drilling a single thin workpiece, be sure to place a backup block of wood under the hole to be drilled to add support to the metal structure.

The drill bit should be inserted in the chuck and tested for trueness or vibration. This may be visibly checked by running the motor freely.

A drill bit that wobbles or is slightly bent should not be used since such a condition causes enlarged holes.

The drill should always be held at right angles to the work regardless of the position or curvatures.

Tilting the drill at any time when drilling into or withdrawing from the material may cause elongation (egg shape) of the hole.

When drilling through sheet metal, small burrs are formed around the edge of the hole.

Burrs must be removed to allow rivets or bolts to fit snugly and to prevent scratching. Burrs may be removed with a countersink cutter. If a countersink is used, it should be rotated by hand or drill slowly.

Always wear safety goggles while drilling.

Drilling titanium or stainless steel

Objective: This shall help you to

- **drill holes in titanium and stainless steel.**
-

Use cobalt alloy drill bits

Cobalt alloy drill bits are designed for hard, tough metals like corrosion-resistant steel and titanium.

It is important for the aircraft technician to note the difference between HSS and cobalt, because HSS drill bits wear out quickly when drilling titanium or stainless.

Cobalt drill bits are excellent for drilling titanium or stainless steel, but do not produce a quality hole in aluminium alloys.

Cobalt drill bits can be recognized by thicker webs and a taper at the end of the drill shank.

Drilling titanium

Titanium can be difficult to drill unless certain procedures are followed. High cutting temperatures can result in a rapid dulling of the drill.

Holes should be as shallow as possible, short, sharp drills of approved design should be used (cobalt alloy drill bits) and low drill speeds should be used.

Drilling stainless steel

When drilling stainless steel, use a cobalt alloy drill bit. The speed of 750 rpm should never be exceeded, and a uniform pressure should always be kept on the drill.

Perform manual bending

Objectives: At the end of this exercise you shall be able to

- calculate developed length of bended sheet metal
- trace and file to correct dimensions
- bend with manual brake.

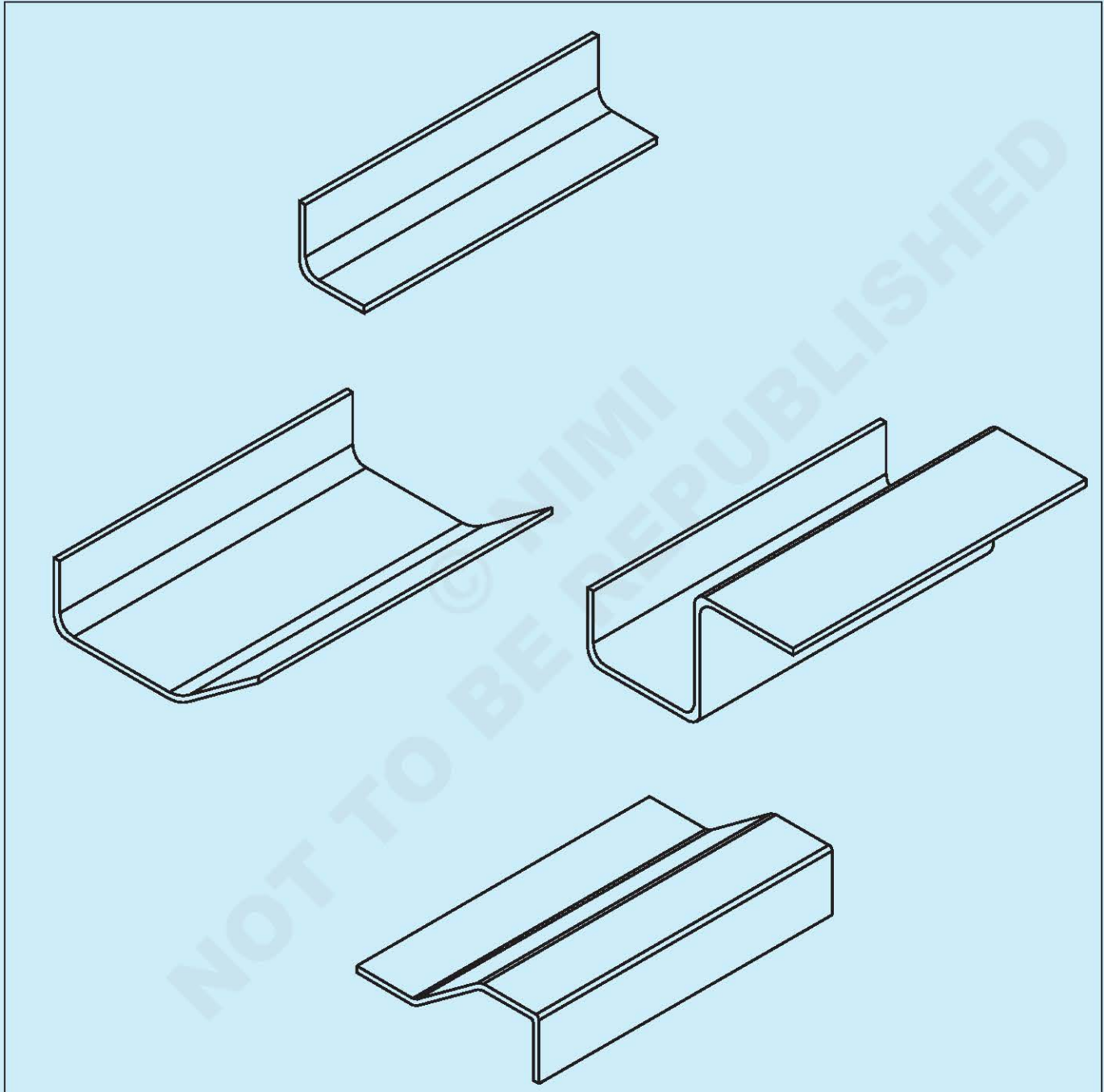

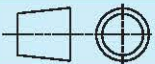
-	-	--	--	--	-	2.1.22
NO.OFF	STOCK SIZE	SEMI-PRODUCT	MATERIAL	PROJECT NO.	PART NO.	EX. NO.
SCALE: NTS	MANUAL BENDING OVERVIEW				DEVIATIONS	TIME:
					CODE NO : AFN2122E1	

TASK 1

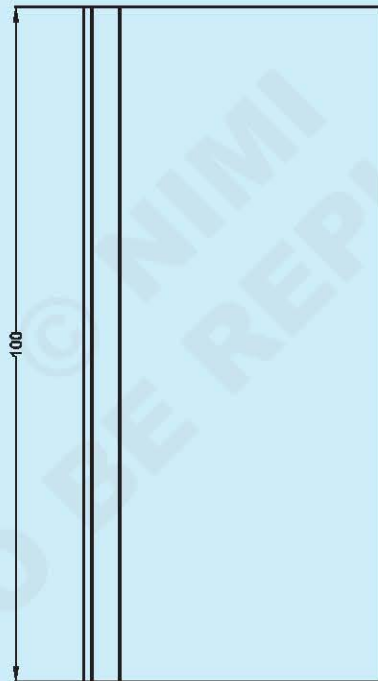
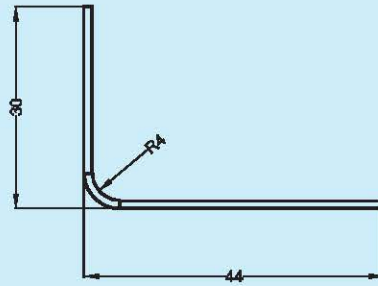

THICKNESS 1.2

1	100 X 80 - THICK. 1.2	-	AW-5086	--	TASK 1	2.1.21
NO.OFF	STOCK SIZE	SEMI-PRODUCT	MATERIAL	PROJECT NO.	PART NO.	EX. NO.
SCALE: NTS	MANUAL BENDING TASK 1				DEVIATIONS	TIME: 3HRS
					CODE NO : AFN2122E2	

TASK 2

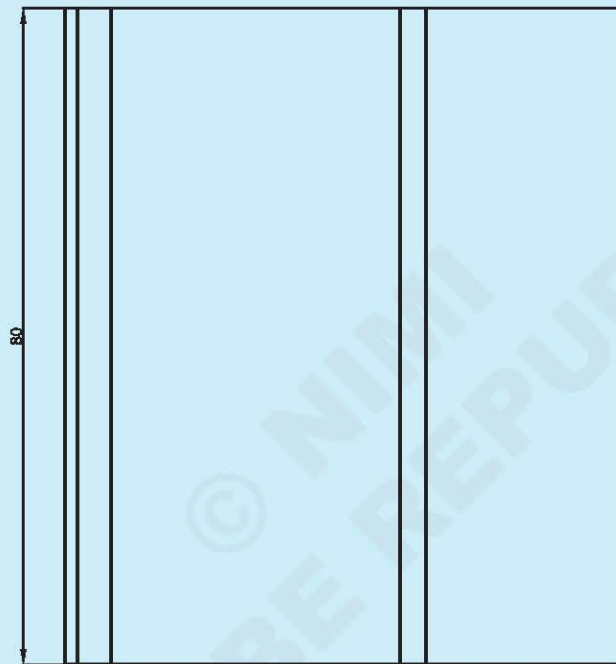
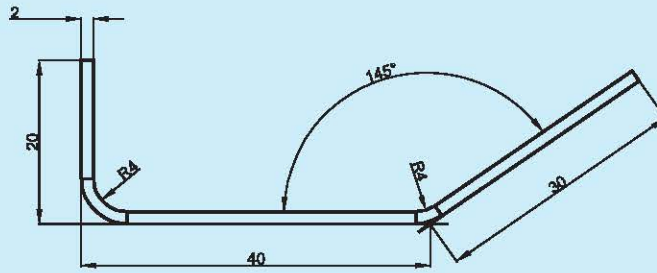

THICKNESS 1.5

1	100 X 80 - THICK.. 1.2	-	AW-5086	-	TASK 2	2.1.22
NO.OFF	STOCK SIZE	SEMI-PRODUCT	MATERIAL	PROJECT NO.	PART NO.	EX. NO.
SCALE: NTS	MANUAL BENDING TASK 2				DEVIATIONS	TIME: 3HRS
					CODE NO : AFN2122E3	

TASK 3

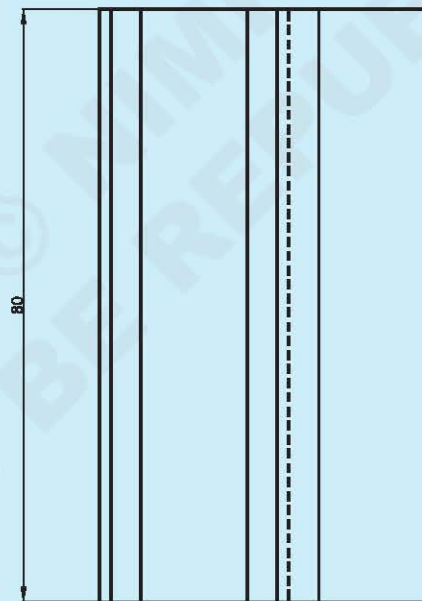
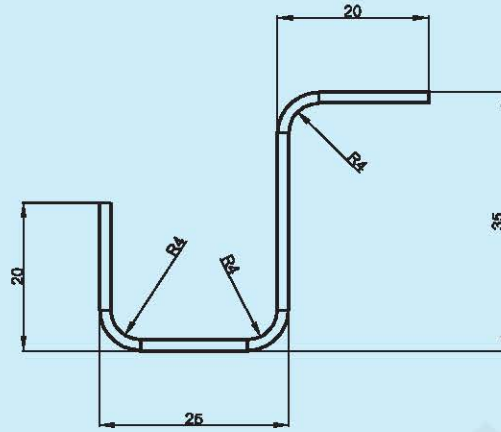

THICKNESS 1.5

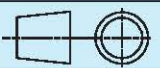
1	100 X 80 - THICK. 1.2	-	AW-5086	--	TASK 3	2.1.22
NO.OFF	STOCK SIZE	SEMI-PRODUCT	MATERIAL	PROJECT NO.	PART NO.	EX. NO.
SCALE: NTS	MANUAL BENDING TASK 3				DEVIATIONS	TIME: 3HRS
					CODE NO : AFN2122E4	

TASK 4

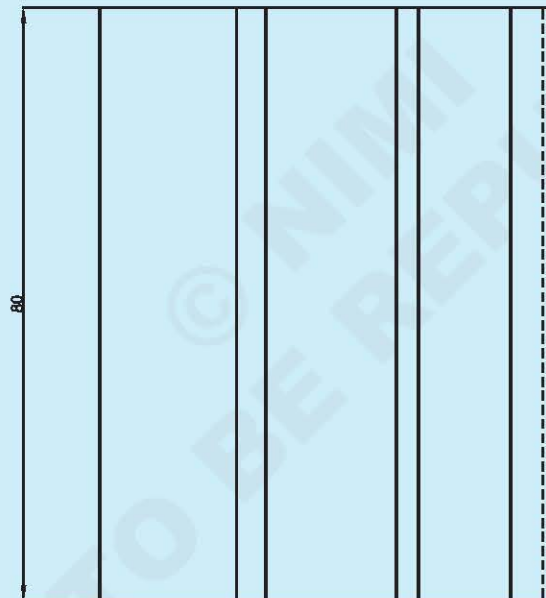
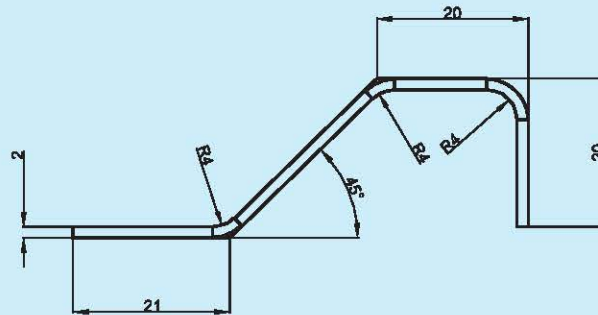

THICKNESS 1.5

1	100 X 80 - THICK.. 1.2	-	AW-5086	-	TASK 4	2.1.22
NO.OFF	STOCK SIZE	SEMI-PRODUCT	MATERIAL	PROJECT NO.	PART NO.	EX. NO.
SCALE: NTS	MANUAL BENDING TASK 4				DEVIATIONS	TIME: 3HRS
					CODE NO : AFN2122E5	

PROCEDURE

TASK 1: Bending #01

- 1 Calculate the developed lengths (see theory booklet for method).
- 2 Complete the drawing below with the calculated dimensions
- 3 Report the dimension on the workpiece with a pencil.
- 4 Cut and file the workpiece. Deburr.
- 5 Bend the workpiece along your marks using bending brake.
- 6 Check the dimensions and the bending angle.

Get it checked by your instructor

- 3 Report the dimension on the workpiece with a pencil.

Do not use sharp edge marking tools (scriber).

Calculate

<p>Calculate of BTLD 1</p> <p>Calculate of BA</p>	<p>Calculate of BTLD 2</p> <p>Sight line =</p>
--	---

Template drawing

Report on the drawing below the values found.

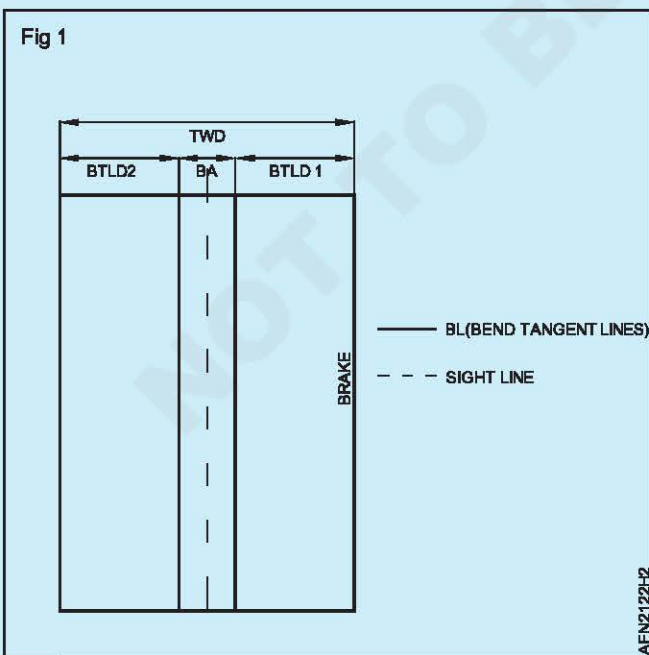

TASK 2: Bending #02

- 1 Calculate the developed lengths (see theory booklet for method, use task 1 as example).
- 2 Draw, as shown in task 1, the bending template.
- 3 Report the dimensions on the workpiece with a pencil.
- 4 Cut and file the workpiece. Deburr.
- 5 Bend the workpiece along your marks using bending brake.
- 6 Check the dimensions and the bending angles.

Get it checked by your instructor.

- 3 Report the dimensions on the workpiece with a pencil.

Do not use sharp edge marking tools (scriber).

Calculate



A large empty rectangular box intended for the student to perform calculations. A faint watermark reading '© NIMI NOT TO BE REPUBLISHED' is visible diagonally across the box.

Template drawing



A large empty rectangular box intended for the student to draw a bending template. A faint watermark reading '© NIMI NOT TO BE REPUBLISHED' is visible diagonally across the box.

TASK 3: Bending #03

- 1 Calculate the developed lengths (see theory booklet for method, use task 1 as example).
- 2 Draw, as shown in task 1, the bending template.
- 3 Report the dimensions on the workpiece with a pencil.
- 4 Cut and file the workpiece. Deburr.
- 5 Bend the workpiece along your marks using bending brake.
- 6 Check the dimensions and the bending angles.

Get it checked by your instructor.

- 3 Report the dimensions on the workpiece with a pencil.

Do not use sharp edge marking tools (scriber).

Calculate

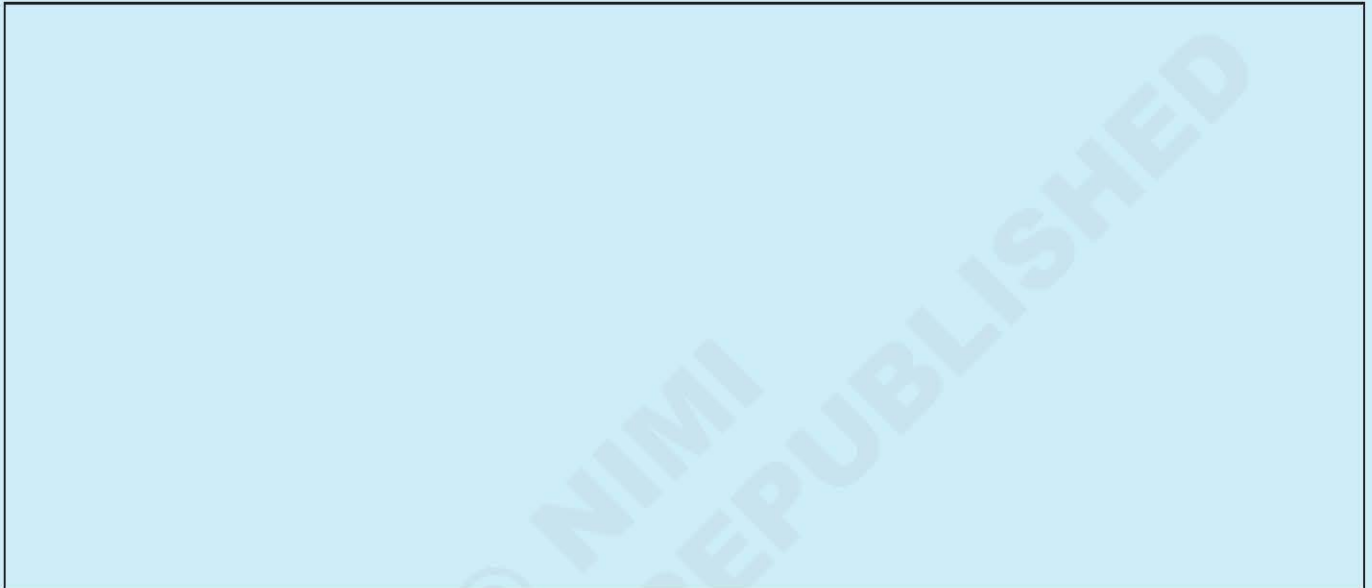

A large empty rectangular box intended for the student to perform calculations. A faint watermark reading "© NIMI NOT TO BE REPUBLISHED" is visible diagonally across the box.

Template drawing

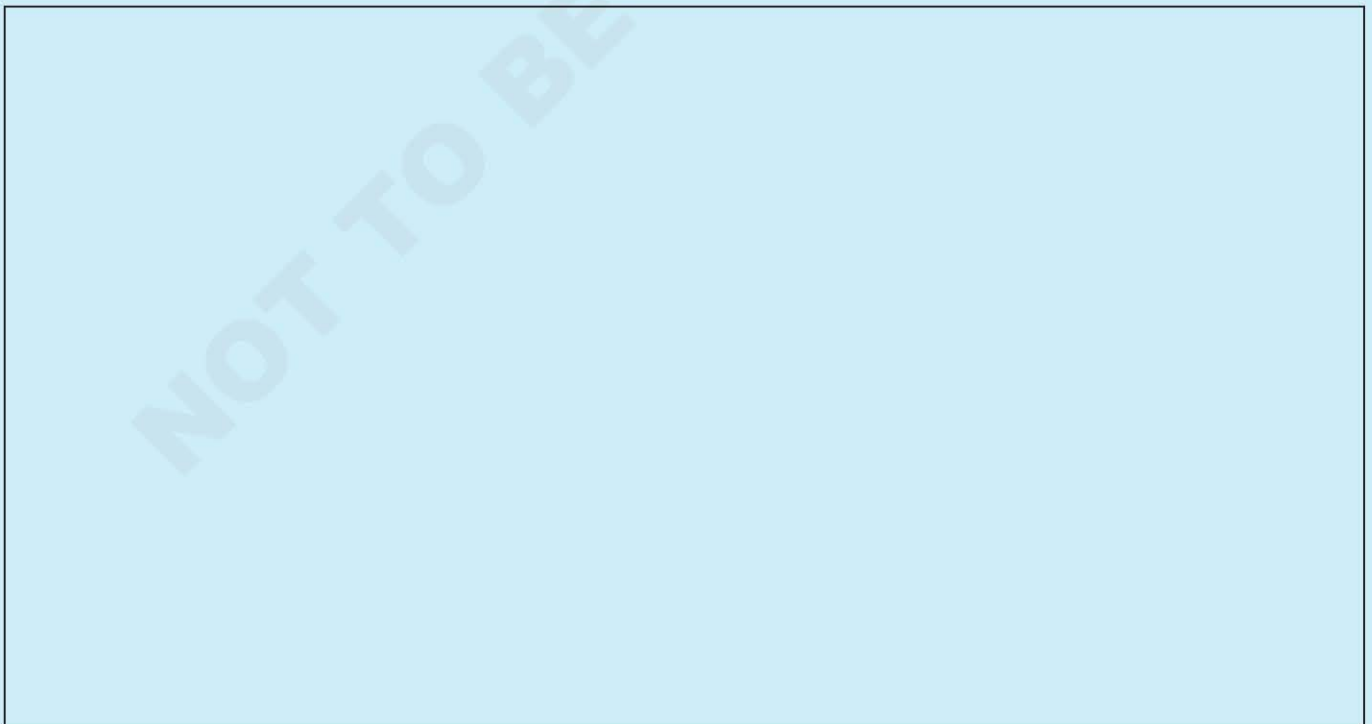

A large empty rectangular box intended for the student to draw the bending template. A faint watermark reading "© NIMI NOT TO BE REPUBLISHED" is visible diagonally across the box.

TASK 4: Bending #04

- 1 Calculate the developed lengths (see theory booklet for method, use task 1 as example).
- 2 Draw, as shown in task 1, the bending template.
- 3 Report the dimensions on the workpiece with a pencil.
- 4 Cut and file the workpiece. Deburr.
- 5 Bend the workpiece along your marks using bending brake.
- 6 Check the dimensions and the bending angles.

Get it checked by your instructor.

Do not use sharp edge marking tools (scriber).

Calculate



A large empty rectangular box intended for the student to perform calculations. A faint watermark reading "© NIMI NOT TO BE REPUBLISHED" is visible diagonally across the box.

Template drawing



A large empty rectangular box intended for the student to draw a bending template. A faint watermark reading "© NIMI NOT TO BE REPUBLISHED" is visible diagonally across the box.

Manufacturing parts for riveting

Objectives: At the end of this exercise you shall be able to

- file part of an assembly
- trace pitch and edge distance
- drill hole in angle workpiece.

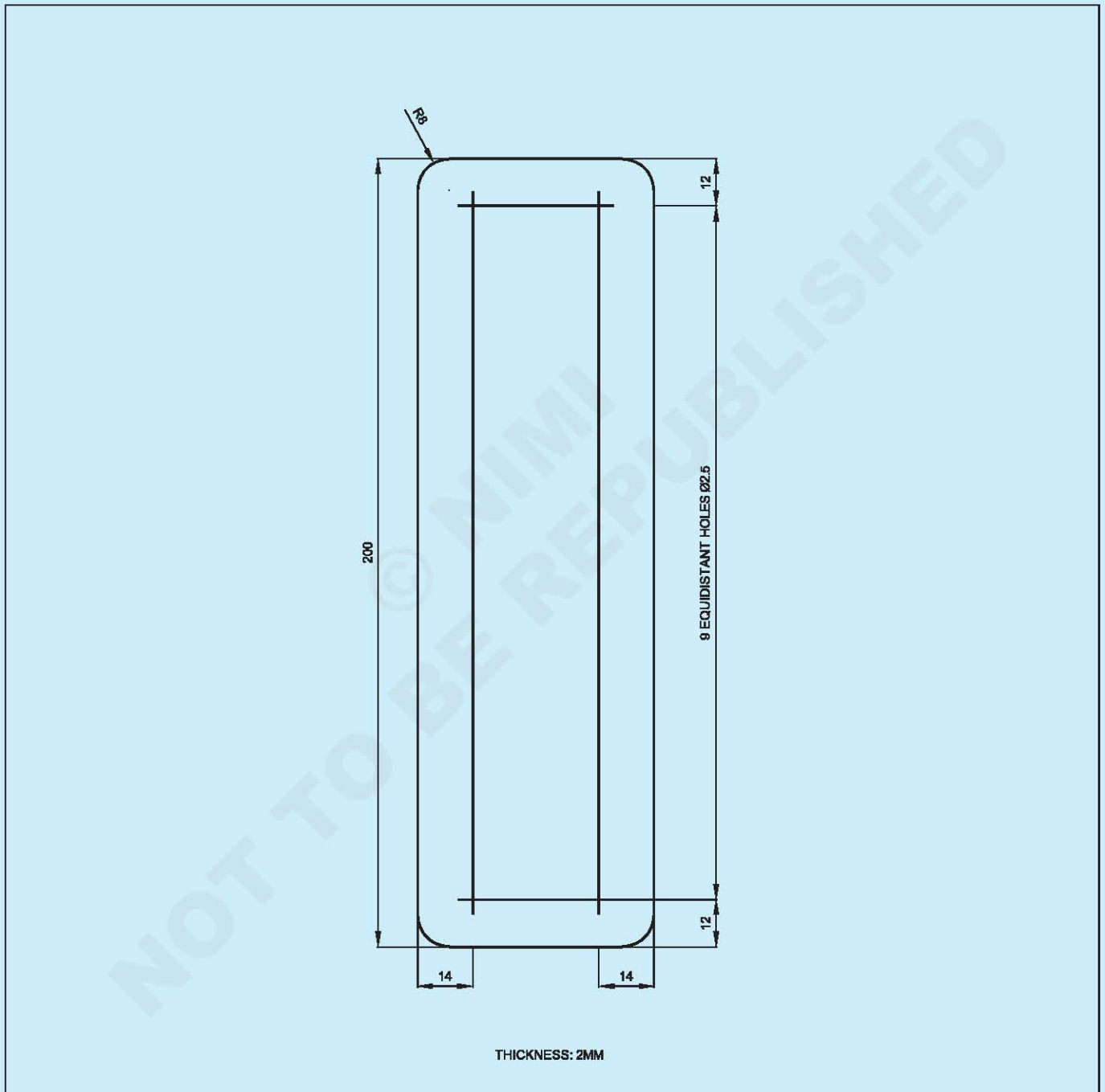

1	60 X 200 - THICK. 2MM	-	AW-2024	--	-	2.1.23
NO.OFF	STOCK SIZE	SEMI-PRODUCT	MATERIAL	PROJECT NO.	PART NO.	EX. NO.
SCALE: NTS		SQUEEZER RIVETING ITEM 03 - PLATE			DEVIATIONS	TIME: 3HRS
					CODE NO : AFN2123E1	

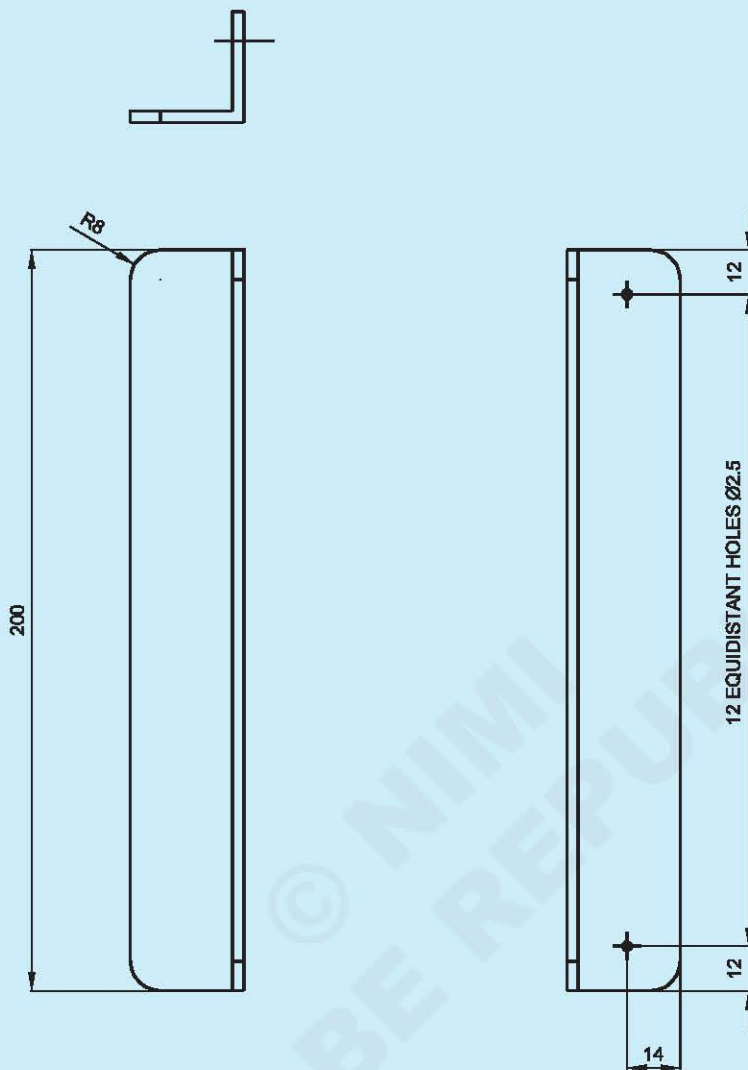

EXTERNAL DIMENSIONS OF THE ANGLE AS DELIVERY (30MM)

1	30 X 30 X 3- 200MM	--	AW-6060	-	-	2.1.23
NO.OFF	STOCK SIZE	SEMI-PRODUCT	MATERIAL	PROJECT NO.	PART NO.	EX. NO.
SCALE: NTS	SQUEEZER RIVETING ITEM 01 - DRILLED ANGLE				DEVIATIONS	TIME: 3HRS
					CODE NO : AFN2123E2	

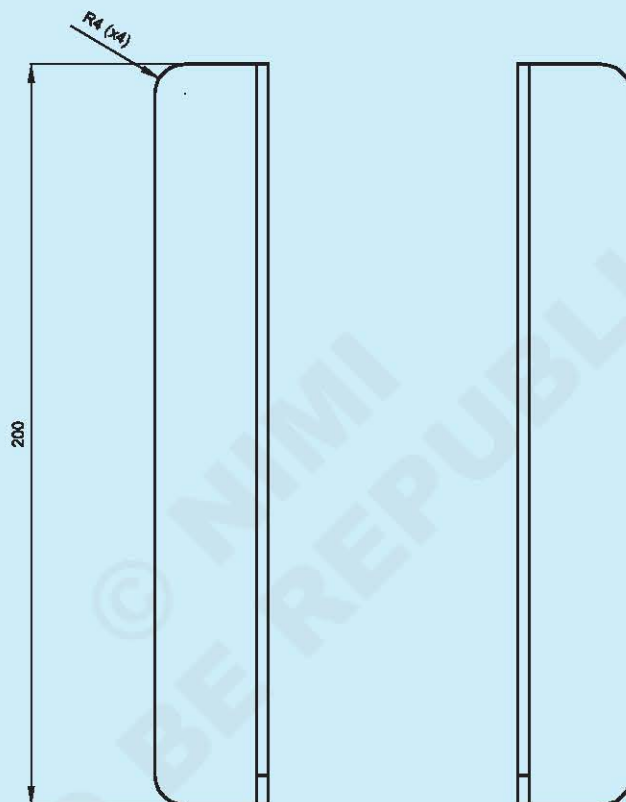
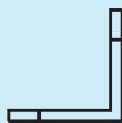

NOT TO BE REPRODUCED

1	30 X 30 X 3 - 20MM	--	AW - 6060	-	-	2.1.23
NO.OFF	STOCK SIZE	SEMI-PRODUCT	MATERIAL	PROJECT NO.	PART NO.	EX. NO.
SCALE: NTS	SQUEEZER RIVETING ITEM 02 -ANGLE				DEVIATIONS	TIME: 3-HRS
					CODE NO : AFN2123E3	

PROCEDURE

TASK 1: ITEM 03 - Plate

- 1 Check dimensions and thickness.
- 2 Mark and file external dimensions and radii.
- 3 Mark the holes positions.
- 4 Punch the centre of the holes.

Drilling diameter 2.5 (all holes)

- 1 Hold the workpiece and drill holes with hand drill.
- 2 Deburr both sides.
- 3 Check diameter and perpendicularity of each hole.

TASK 2: ITEM 01 - Angle

- 1 Check dimensions and thickness of the angle.
- 2 Mark external dimensions and file.
- 3 Mark and file radii.
- 4 Mark the holes positions.
- 5 Punch the centre of the holes.

Drilling diameter 2.5 (all holes)

- 1 Hold the workpiece and drill holes with hand drill.
- 2 Deburr both sides.
- 3 Check diameter and perpendicularity of each hole.

TASK 3: ITEM 02 - ANGLE

- 1 Check dimensions and thickness of the angle.
- 2 Mark external dimensions and file.
- 3 Mark and file radii.

REPORT SHEET / ITEM 3 – PLATE

Dimensions	Theoretical		Measured
External dimensions	200	±0.5	
	60	±0.5	
Radii	8	±0.5	
	8	±0.5	
	8	±0.5	
	8	±0.5	

Drilling	Theoretical		Measured
Edge distance	14	+1 / -0	
	12	+1 / -0	
	12	+1 / -0	
	12	+1 / -0	
Number of holes	18		
Drilling quality	-	<input type="checkbox"/> OK	<input type="checkbox"/> NOK
Deburring quality	-	<input type="checkbox"/> OK	<input type="checkbox"/> NOK

REPORT SHEET / ITEM 1 – DRILLED ANGLE

Dimensions	Theoretical		Measured
External dimensions	200	±0.5	
	8	±0.5	
Radii	8	±0.5	
	8	±0.5	
	8	±0.5	

Drilling	Theoretical		Measured
Edge distance	14	+1 / -0	
	12	+1 / -0	
Number of holes	12		
Drilling quality	-		<input type="checkbox"/> OK <input type="checkbox"/> NOK
Deburring quality	-		<input type="checkbox"/> OK <input type="checkbox"/> NOK

REPORT SHEET / ITEM 2-ANGLE

Dimensions	Theoretical		Measured
External dimensions	200	±0.5	
Radii	8	±0.5	
	8	±0.5	
	8	±0.5	
	8	±0.5	

Riveting with squeezer

Objectives: At the end of this exercise you shall be able to

- put into place the parts of an assembly
- clamp together parts
- rivet with squeezers.

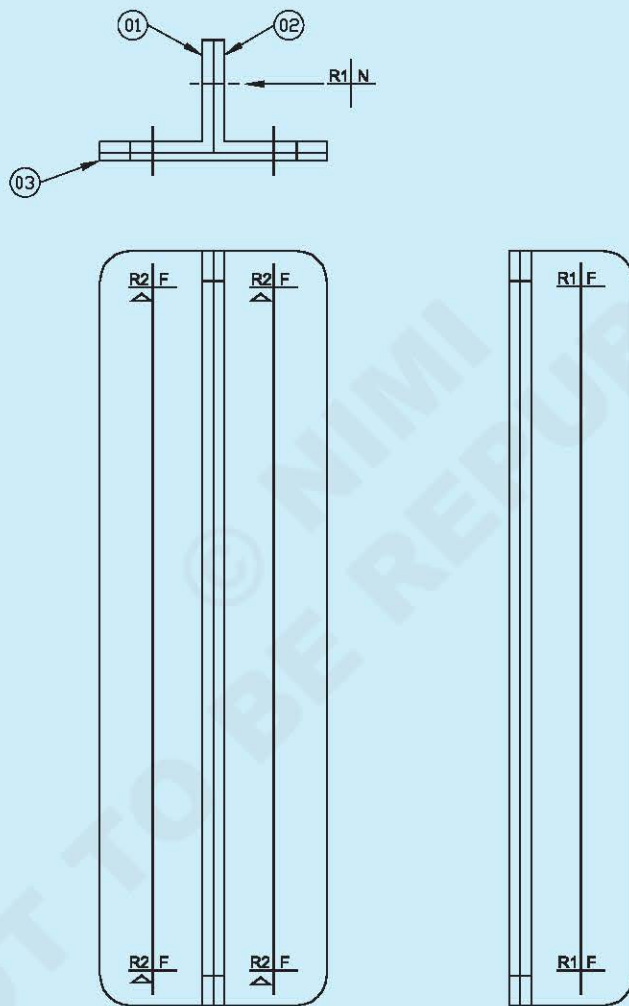

R1 > UNIVERSAL SOLID RIVET, DIAMETER 3.2 (1/8), ALUMINIUM 2117
 R2 > COUNTERSUNK HEAD RIVERT , DIAMETER 4 (5/32"), ALUMINIUM 2117

-	-	→ 2.1.23	-	-	-	2.1.24
NO.OFF	STOCK SIZE	SEMI-PRODUCT	MATERIAL	PROJECT NO.	PART NO.	EX. NO.
SCALE: NTS	SQUEEZER RIVETING ASSEMBLY				DEVIATIONS	TIME: 15-HRS
					CODE NO : AFN2124E1	

PROCEDURE

TASK 1: Pre - Assembly

Angle assembly

- 1 Check the parts.
- 2 On a flat surface (e.g. surface plate), join the two angles 01 and 02 together.
- 3 Hold them in place with 2 clamps. (Fig 1)

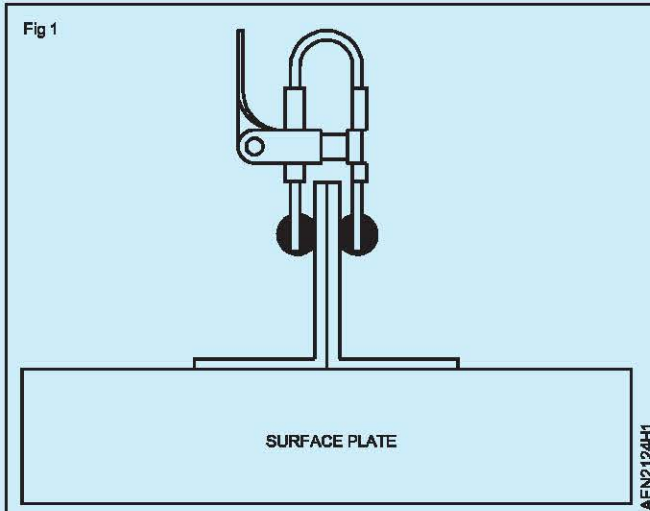

The drilling diameter is 2.5 mm.

- 1 Counter-drill a hole at one end and clamp
- 2 Counter-drill a hole in the centre and clamp
- 3 Counter-drill the hole at the other end and clamp.

- 1 Check that the position is always correct.

If so, counter-drill the other holes.

If not, remove the clamps, replace the angles together and start again using new holes.

- 2 Apply a minimum of 33% temporary fasteners.

Angles on plate assembly

- 1 Position the clamped angles on the flat workpiece and V-block or square.
- 2 Heck for flush fit.
- 3 Hold in place with clamps. (Fig 3)

The drilling diameter is 2.5 mm.

- 1 Counter-drill the two outer holes of each angles and clamp each of them. (Fig 4)
- 2 Check the positioning.
- 3 If the parts have not shifted, counter-drill the other holes and clamp at 33%.

Counter-drilling

- 4 The counter-drilling to the final diameter is carried out on all clamped parts.
- 5 Counter-drilling at 3.3 mm the holes of the angles.

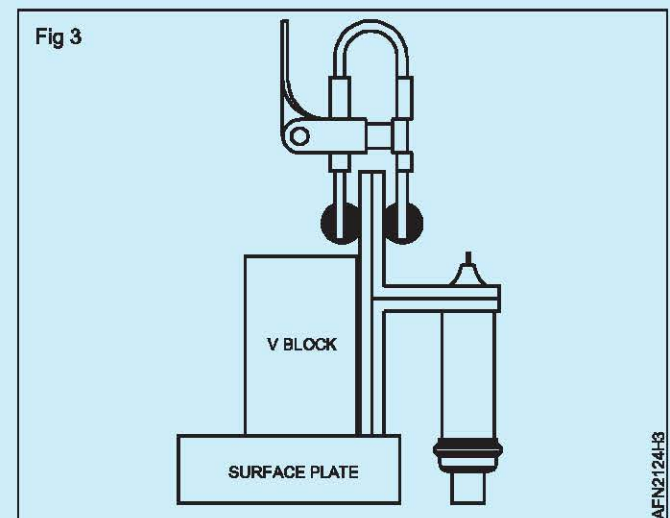
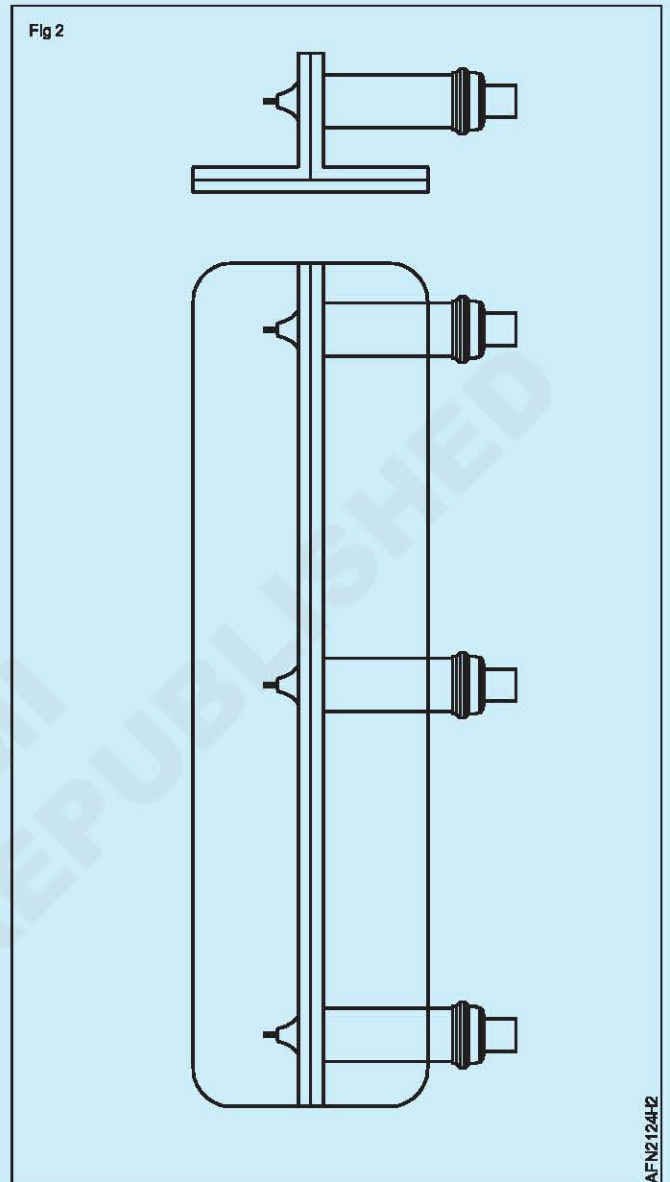

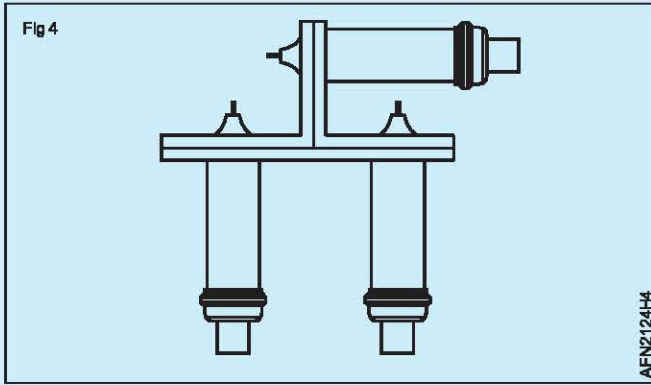

- 6 Drill the unclamped holes and insert the new pins.
- 7 Remove the pins with a diameter of 2.5 mm and finish the counter-drilling.
- 8 Counter-drill from the outside at 4.1 mm the holes of item 03 with the angles.
- 9 Drill the unclamped holes and insert the pins.
- 10 Remove the pins with a diameter of 2.5 mm and finish the counter-drilling.

It is recommended to first drill at 3.3 mm and then at 4.1 mm to facilitate the operation.

- 11 Mark the workpieces by drawing marks with pencil.
- 12 Dismantle the parts and deburr.
- 13 Reassemble the workpieces with pins using the marks previously made.

Countersinking

- 14 On a metal sheet of the same thickness as the assembly to be made, adjust the microstop cutter.
- 15 Check with a rivet and a comparator.

Allowable protrusion: -0 / + 0.1 mm. (Fig 5)

- 1 On the piece, perform the countersinking.
- 2 Check with a rivet and a comparator.

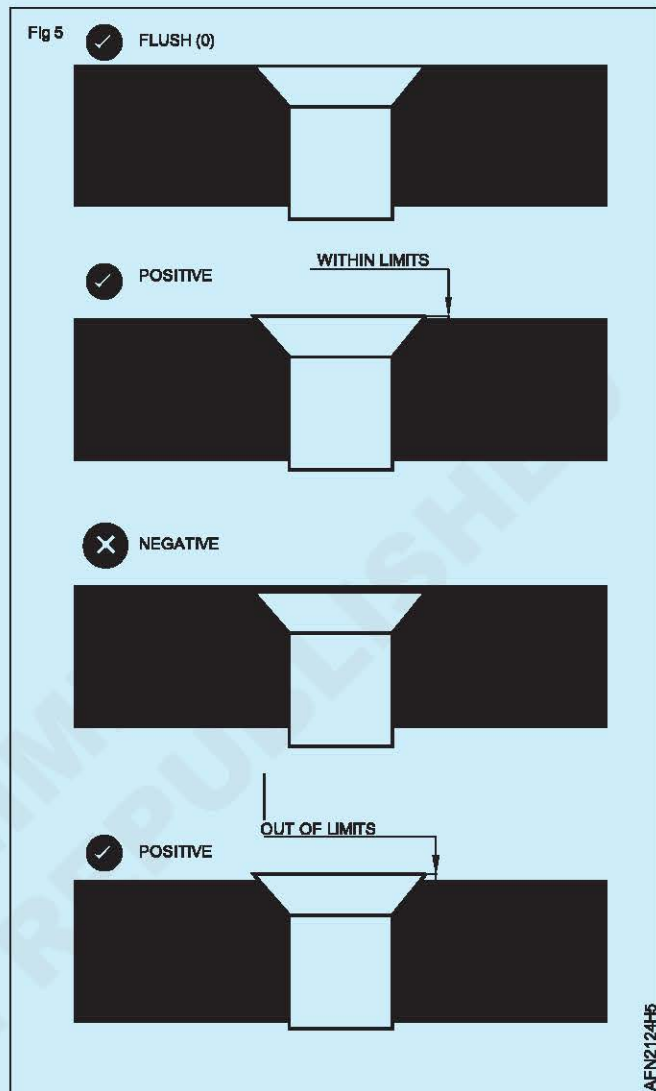

TASK 2: Riveting

The parts are clamped at a minimum of 33%.

Riveting of rivets diameter 3.3 mm (1/8")

- 1 Use type Alligator riveting squeezer.
- 2 Select and position the rivet sets.

The rivet head must be on the side of the fixed yoke of the squeezer.

- 1 Adjust the spacing between the rivet sets.
- 2 Rivet all unclamped holes.
- 3 Remove the pins and finish riveting.
- 4 Check each rivet with a gauge.

Riveting of rivets diameter 4.1 mm (5/32")

- 1 Use type C riveting squeezer.
- 2 Select and position the rivet sets.

The rivet head must be on the side of the fixed yoke of the squeezer.

- 1 Adjust the spacing between the rivet sets.
- 2 Rivet all unclamped holes.
- 3 Remove the pins and finish riveting.
- 4 Check each rivet with a gauge.

REPORT SHEET

Report by drawing and measurement the defects on each rivet.

Use red pen for non-allowable defects.

Use blue or black pen for allowable defects.

Universal rivet head row

Manufactured head side

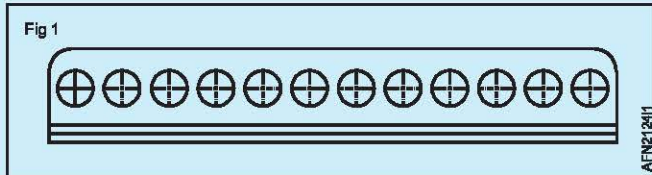

Shop head side

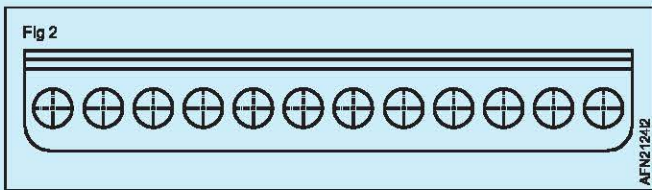

Countersink head rivet rows

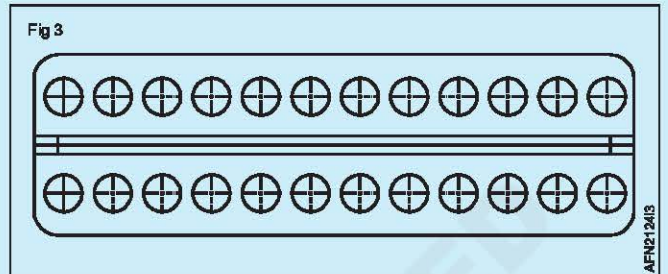

Manufactured head side

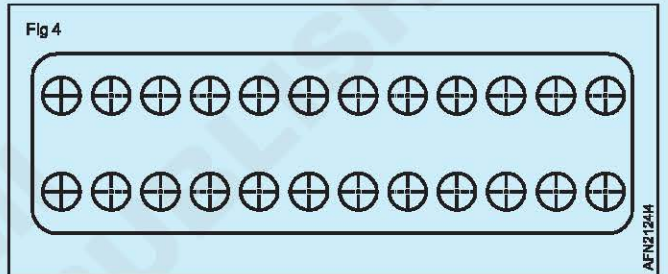

Part manufacturing - Little bended aircraft 1 - ATR

Objectives: At the end of this exercise you shall be able to

- report by punching a drawing
- put in position the parts of an assembly
- clamp together parts.

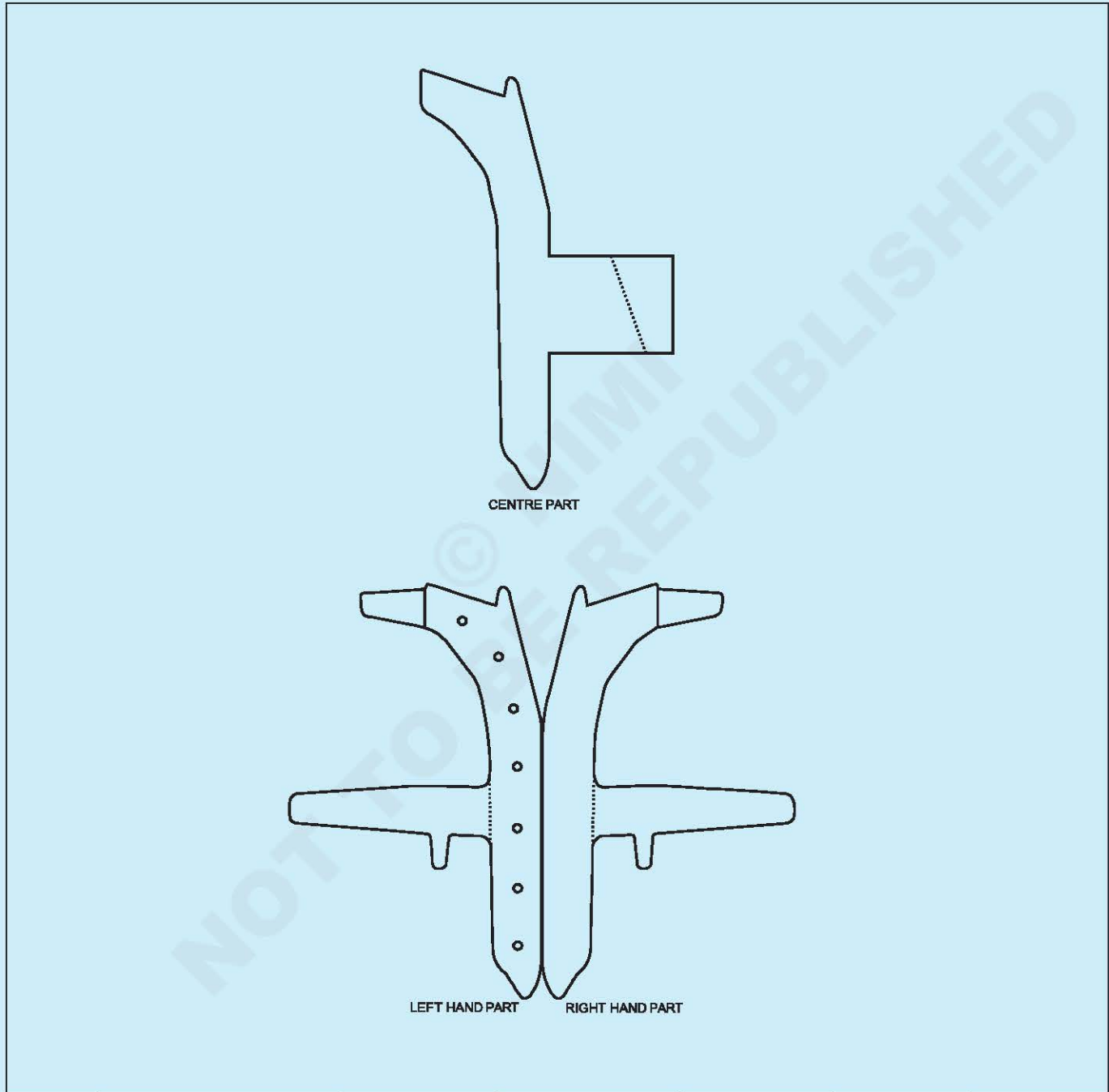

-	-	--	--	-	--	2.1.25
NO.OFF	STOCK SIZE	SEMI-PRODUCT	MATERIAL	PROJECT NO.	PART NO.	EX. NO.
SCALE: NTS	PARTS MANUFACTURING LITTLE BENDED AIRCRAFT 1				DEVIATIONS	TIME: 20HRS
					CODE NO : AFN2125E1	

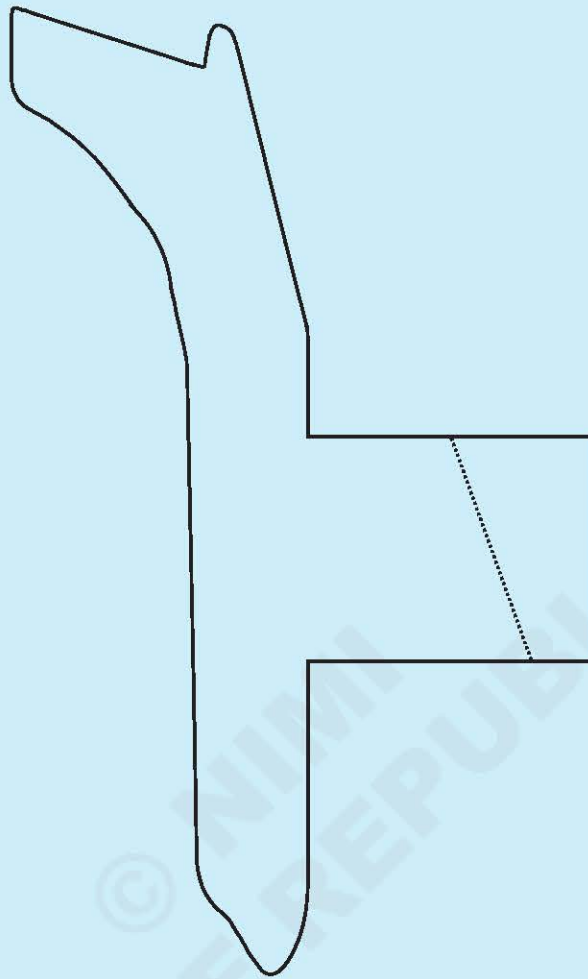

MATERIAL : 6086
 THICKNESS: 2MM
 DASHED LINE IS THE BENDING LINE

© NIMA
 NOT TO BE REPRODUCED

1	100 X 180 - 2MM	--	AW-5086	-	--	2.1.25
NO.OFF	STOCK SIZE	SEMI-PRODUCT	MATERIAL	PROJECT NO.	PART NO.	EX. NO.
SCALE: NTS		LITTLE BENDED AIRCRAFT 1 TEMPLATE CENTRE PART			DEVIATIONS	TIME: 20HRS
					CODE NO : AFN2125E2	

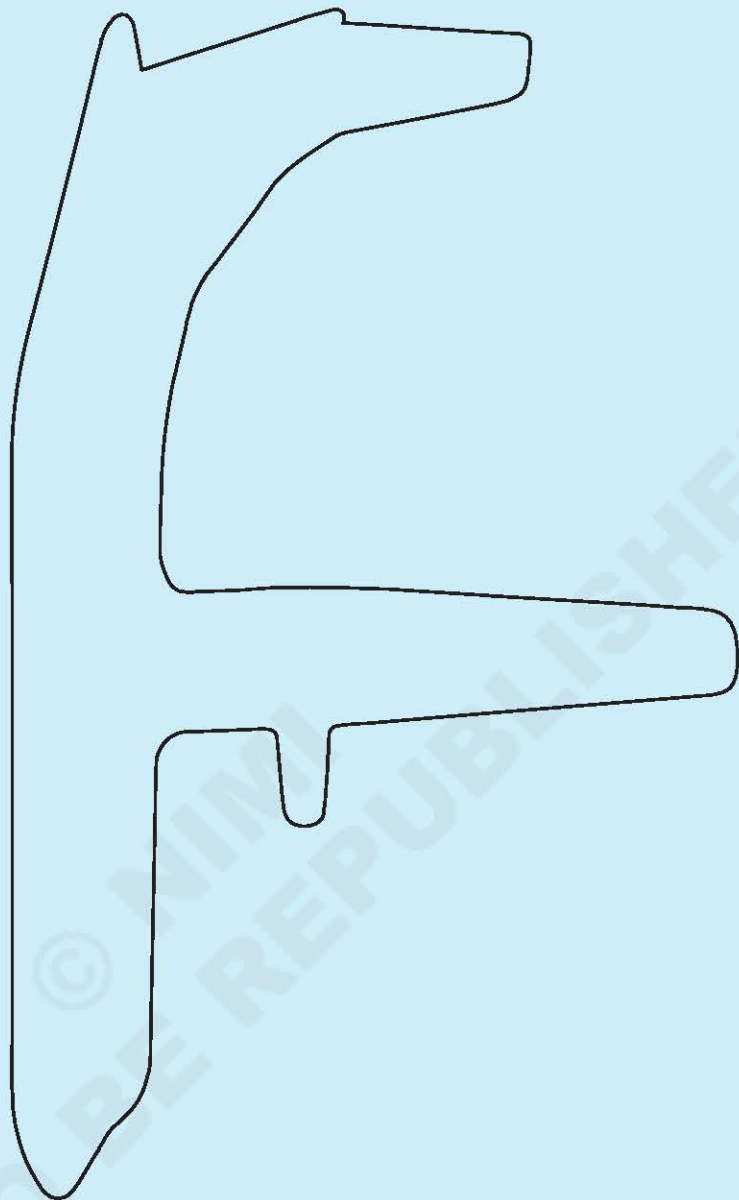

MATERIAL: 5086
THICKNESS: 1.5MM

-	100 X 160 - 1.5MM	-	AW-5086	-	--	2.1.25
NO.OFF	STOCK SIZE	SEMI-PRODUCT	MATERIAL	PROJECT NO.	PART NO.	EX. NO.
SCALE: NTS	LITTLE BENDED AIRCRAFT 1 TEMPLATE RH PART				DEVIATIONS	TIME: 20HRS
					CODE NO : AFN2125E3	

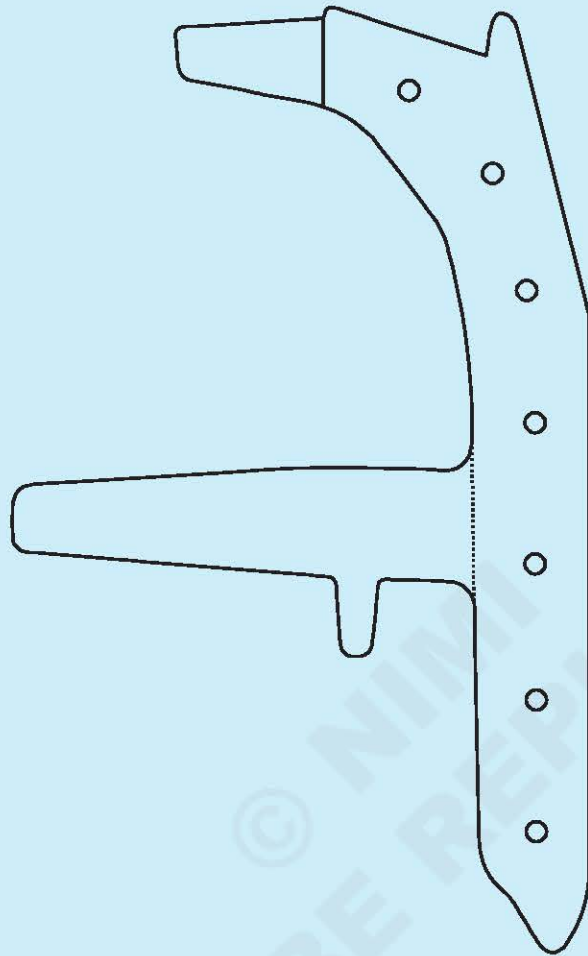

MATERIAL:5086
 THICKNESS:1.5MM
 DRILL HOLES DIAMETER 2.5MM

© NIMI
 NOT TO BE RE-PUBLISHED

1	100 X 160 - 1.5MM	-	-	-	-	2.1.25
NO.OFF	STOCK SIZE	SEMI-PRODUCT	MATERIAL	PROJECT NO.	PART NO.	EX. NO.
SCALE: NTS		LITTLE BENDED AIRCRAFT 1 TEMPLATE RH PART			DEVIATIONS	TIME: 20HRS
					CODE NO : AFN2134E4	

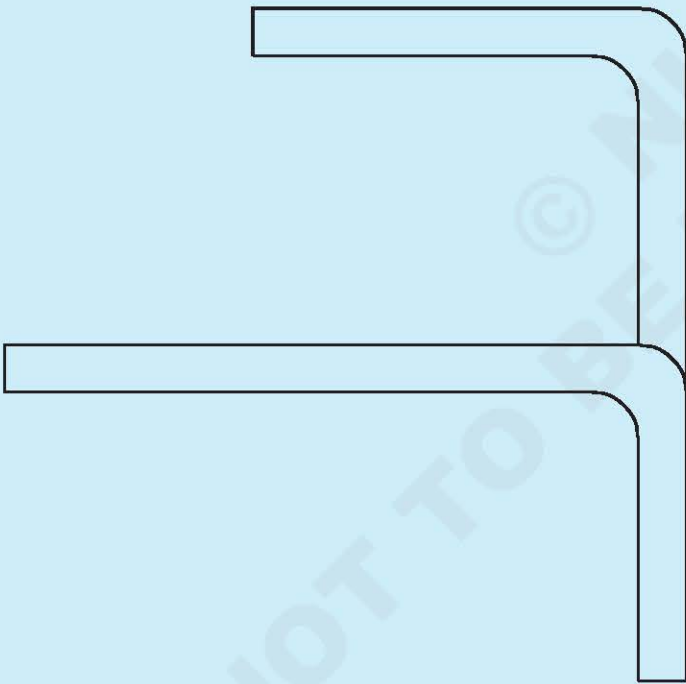
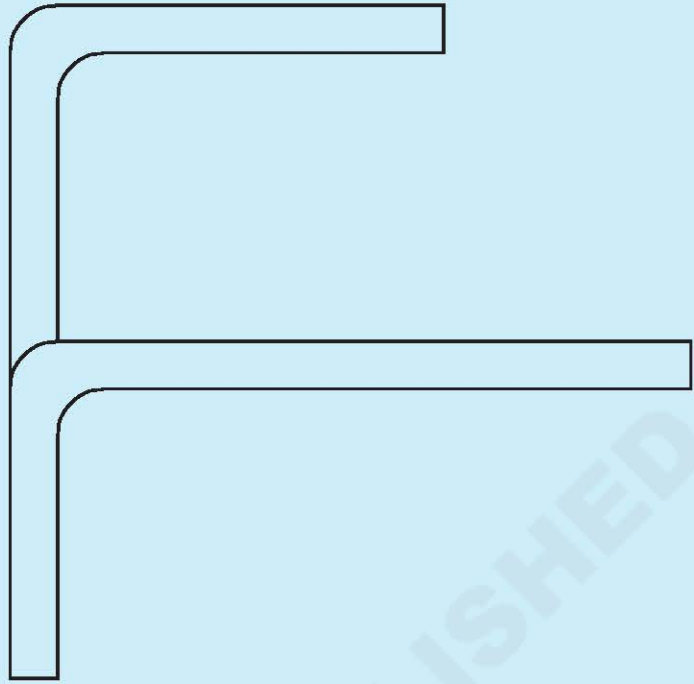

BENDING IN DASHED LINES
 ANGLES: 90°
 RADIUS SEE TABLES OF RADIUS BENDING

-	--	--	AW-5086	-	-	2.1.25
NO.OFF	STOCK SIZE	SEMI-PRODUCT	MATERIAL	PROJECT NO.	PART NO.	EX. NO.
SCALE: NTS	LITTLE BENDED AIRCRAFT 1 TEMPLATE RH AND LH PARTS				DEVIATIONS	TIME: 20HRS
					CODE NO : AFN2125E4	

PROCEDURE

TASK 1: Centre part manufacturing

Tracing

- 1 Trace the outline of the profile of each part, using tracing paper

Punching the profile contour

- 2 On a flat surface (e.g. surface plate), join the two angles 01 and 02 together.

Cutting and filing

- 1 Cut with a saw as close as possible to the line.
- 2 Adjust and control by comparison with the original profile.
- 3 Deburr accurately.

TASK 2: Right part manufacturing

Tracing

- 1 Trace the outline of the profile of each part, using tracing paper.

Punching the profile contour

- 2 On the workpiece, point with a punch the contour of the central part.

Cutting and filing

- 3 Cut with a saw as close as possible to the line.
- 4 Adjust and control by comparison with the original profile.
- 5 Deburr accurately

TASK 3: Left part manufacturing

Tracing

- 1 Trace the outline of the profile of each part, using tracing paper.

Punching the profile contour

- 2 On the workpiece, point with a punch the contour of the central part.

- 4 Adjust and control by comparison with the original profile.
- 5 Deburr accurately.

Drilling

- 6 Punch the centres of the holes.
- 7 Drill to 2.5 mm diameter.

Cutting and filing

- 3 Cut with a saw as close as possible to the line.

TASK 4: Pre- assembly

- 1 Put the three parts together in the following order:

Left part.

Centre part.

Right part.

The edges must match.

- 2 Hold with clamps.

- 3 Counter-drill existing holes.

- 4 Clamp at each hole.

If necessary, file to ensure that the edges are flush.

- 5 Mark the left and right parts with pencil.

- 6 Disassemble and deburr.

TASK 5: Bending

Bending of the centre part

- 1 Using a brake, bend the two elements according to the dotted lines of the template. Angle 90°.

NOTE: The left and right parts are symmetrical. The bend angles are shown on the “ BENDING RH AND LH PARTS “ drawing (sheet 4).

Bending of the left part

- 1 Using a brake, bend the two elements according to the dotted lines of the template.

Caution:

As the bends are misaligned, take care to choose the bending point without damage the piece.

Bending of the right part

- 1 Using a brake, bend the two elements according to the dotted lines of the template.

Caution:

As the bends are misaligned, take care to choose the bending point without damage the piece.

Riveting

NOTE:

The rivets to be used are 2.4 mm (3/32”) diameter, aluminium 2117, universal head.

- 1 Clamp the three parts together with clamps. Clamping rate of 50%.
- 2 Calculate rivet lengths.
- 3 Prepare the riveting squeezer with rivet sets.
- 4 Rivet unclamped holes.
- 5 Remove the pins and rivet the other holes.

Tracing paper

Thin, transparent paper that is used for copying a picture by putting it on top of the picture and drawing over its lines.

Part manufacturing – Drilling large diameter

Objectives: At the end of this exercise you shall be able to

- drill large diameter with hole saw and step drill
- punch letters or numbers.

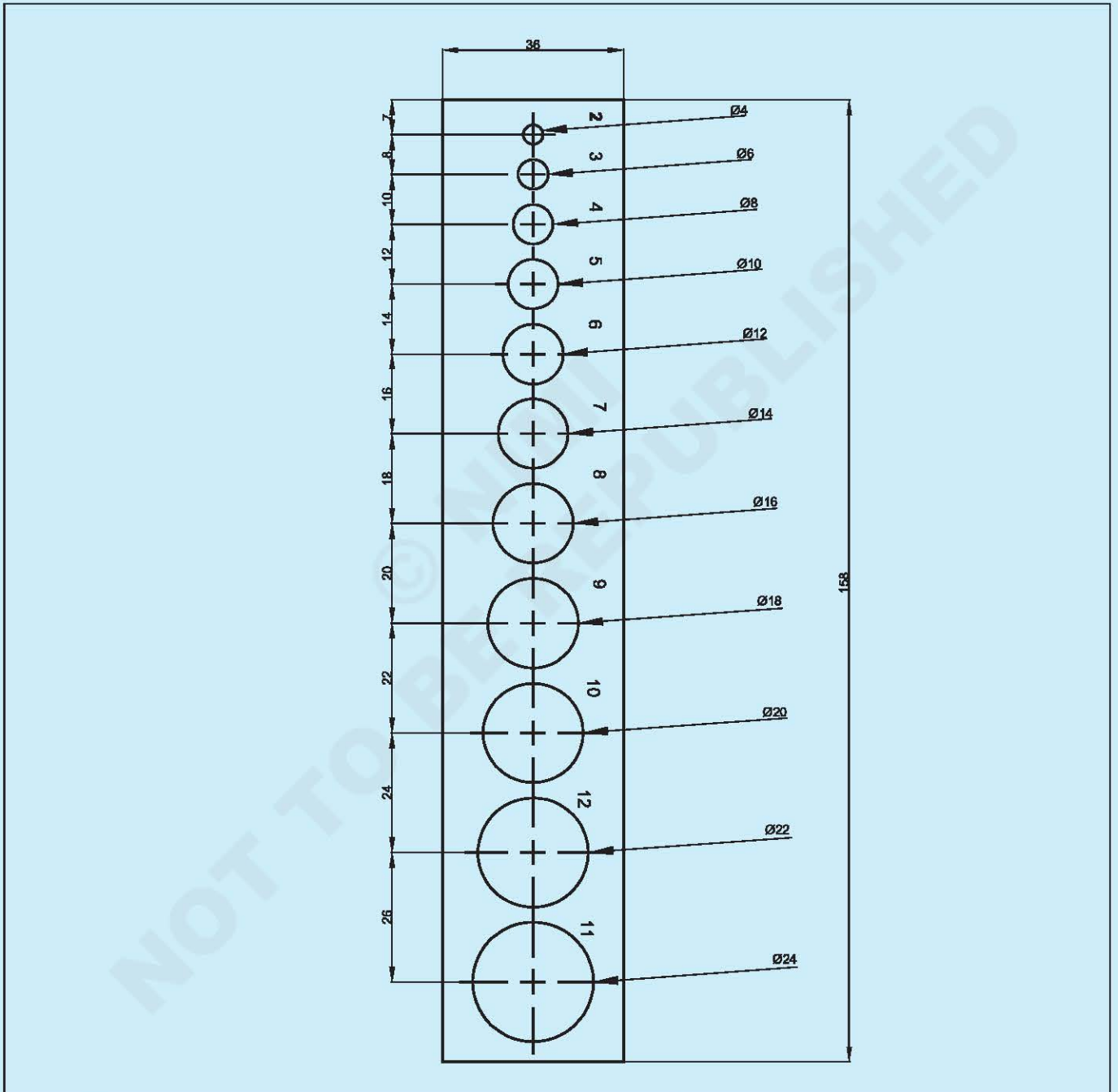

1	195 X 40 -2MM	-	AW - 2024	--	--	2.1.26
NO.OFF	STOCK SIZE	SEMI-PRODUCT	MATERIAL	PROJECT NO.	PART NO.	EX. NO.
SCALE: NTS	DRILLING LARGES HOLES				DEVIATIONS	TIME: 10HRS
					CODE NO : AFN2126E1	

Job Sequence

TASK 1: Drilling

- 1 Check dimensions and thickness.
- 2 Mark and file external dimension.
- 3 Mark the holes positions.
- 4 Punch the centre.

Drilling diameter 2.5 (all holes)

- 1 Hold the workpiece and drill holes with hand drill.
- 2 Deburr both sides.

Drilling diameter 3.3 (all holes)

- 1 Hold the workpiece and drill holes with hand drill.
- 2 Deburr both sides.

Drilling diameter 4.0 (all holes)

- 1 Hold the workpiece and drill holes with hand drill.

Write in pencil the final diameter of each hole

Drilling diameter 5.0 (One hole)

- 1 Hold the workpiece.
- 2 Drill the hole corresponding to the 5 mm diameter.

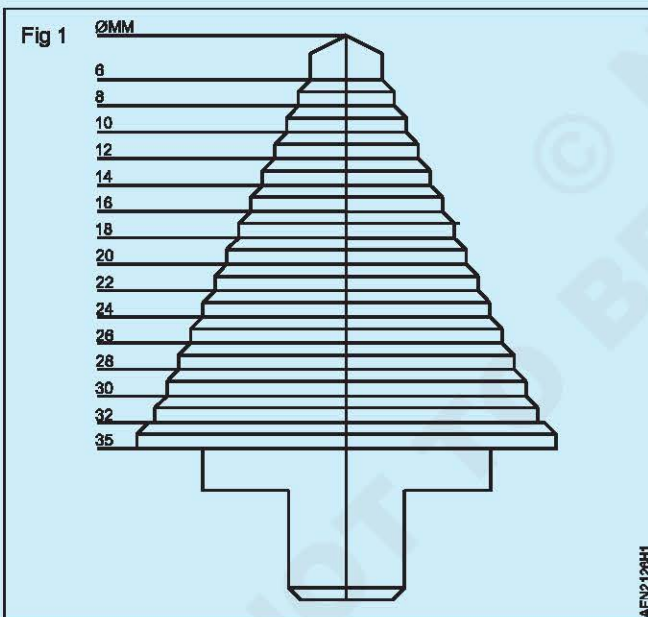

Drilling diameter 6.0 (Holes with diameters from 6 to 24 mm)

- 1 Hold the workpiece and drill holes with hand drill.

Drilling with step drill (Holes with diameters from 7 to 18 mm)

- 1 Hold the workpiece.
- 2 Drill holes with hand drill and step drill.

Drilling with hole saw (Holes with diameters from 20 to 24 mm)

- 1 Hold the workpiece.
- 2 Drill holes with hand drill and step drill.

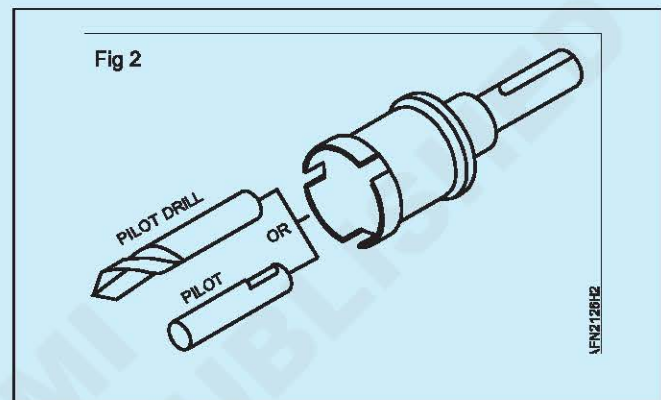

Deburr holes

Depending on the diameter, deburr with a countersink (manual or drill) or deburring hand tools.

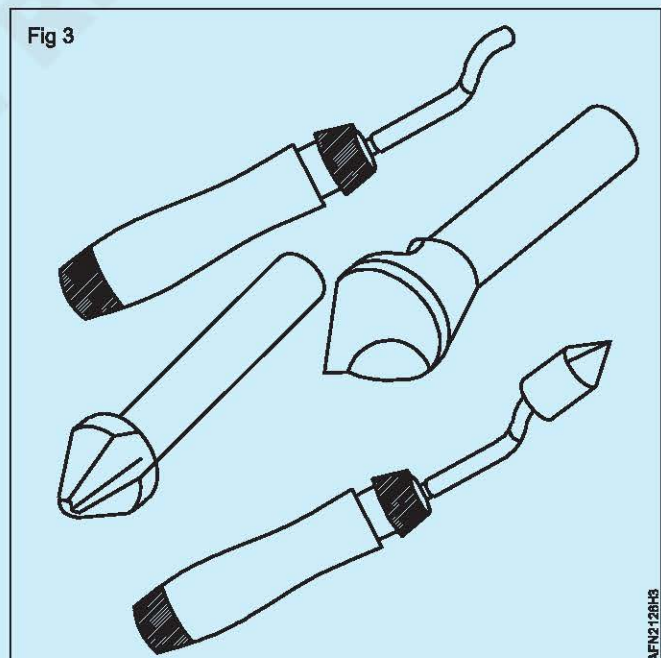

TASK 2: Marking by punching

Check the diameter of each holes.

Use the punches in the following manner:

- i Mark out the guidelines for the symbols.
- ii Check that you have the correct symbol.
- iii Position the punch so that the symbol will be in line, square, correctly spaced and the correct way up.
- iv Hold the punch in a vertical position.
- v Hold the hammer vertically above the punch.
- vi Strike the punch squarely with one firm blow.

Each symbol must be made with a single blow. A second blow gives a distorted second impression.

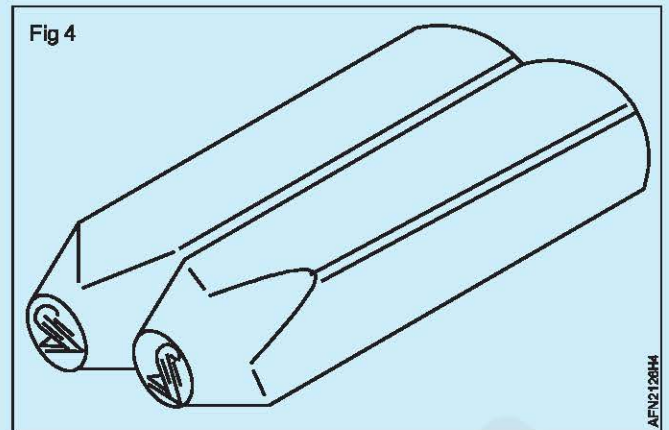

Part manufacturing – Rivet gauge manufacturing

Objectives: At the end of this exercise you shall be able to

- manufacture rivet gauge
- check dimensions with close tolerance.

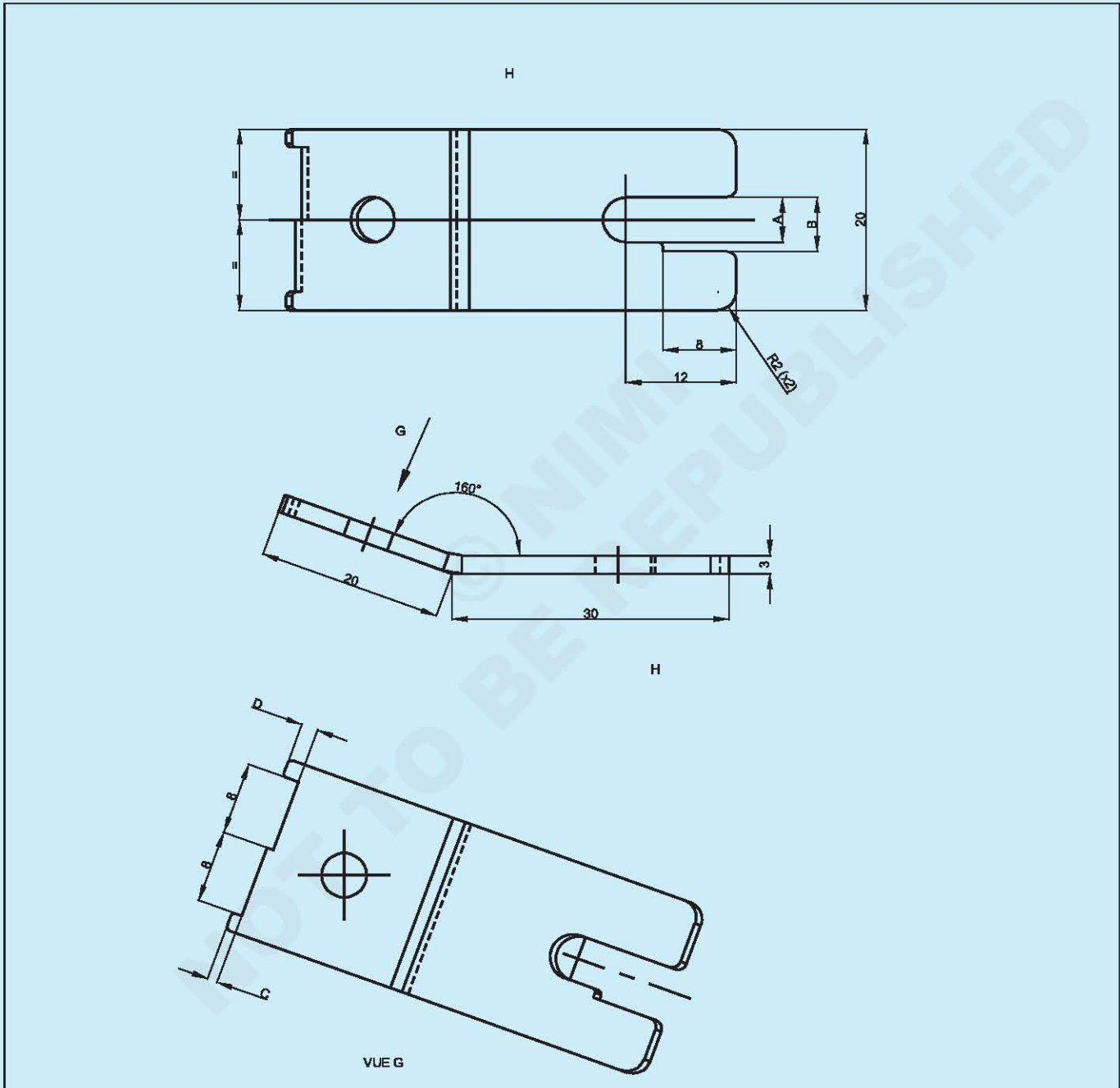

1	22 X 50 - 2MM	-	ALSI 316L	-	--	2.1.36
NO.OFF	STOCK SIZE	SEMI-PRODUCT	MATERIAL	PROJECT NO.	PART NO.	EX. NO.
SCALE: NTS					DEVIATIONS	TIME: 10-HRS
					MANUFACTURE RIVET GAUGE	
					CODE NO : AFN2127E8	

Job Sequence

- 1 Check dimensions and thickness.
- 2 Mark and file external dimension.
- 3 Mark and file radii.
- 4 Mark the holes positions.
- 5 Punch the centre.
- 6 Hold the workpiece and drill holes with hand drill.

See dimensions in the table below.

- 7 Deburr both sides.
- 8 Mark the check zones.

See dimensions in the table below.

- 1 Saw and file.
- 2 Check the dimensions.
- 3 Mark the bending line.
- 4 Bend the workpiece.
- 5 Punch the diameter.

	A	B	C
3.2 Rivet gauge	5 mm	6mm	1.1mm
4.0 Rivet gauge	6.2 mm	7.5mm	1.3mm
Tolerance	$\pm 05\text{mm}$		

Part manufacturing - Little bended aircraft 2 - Fouga magister

Objectives: At the end of this exercise you shall be able to

- report by punching a drawing
- put in position the parts of an assembly
- clamp together parts.

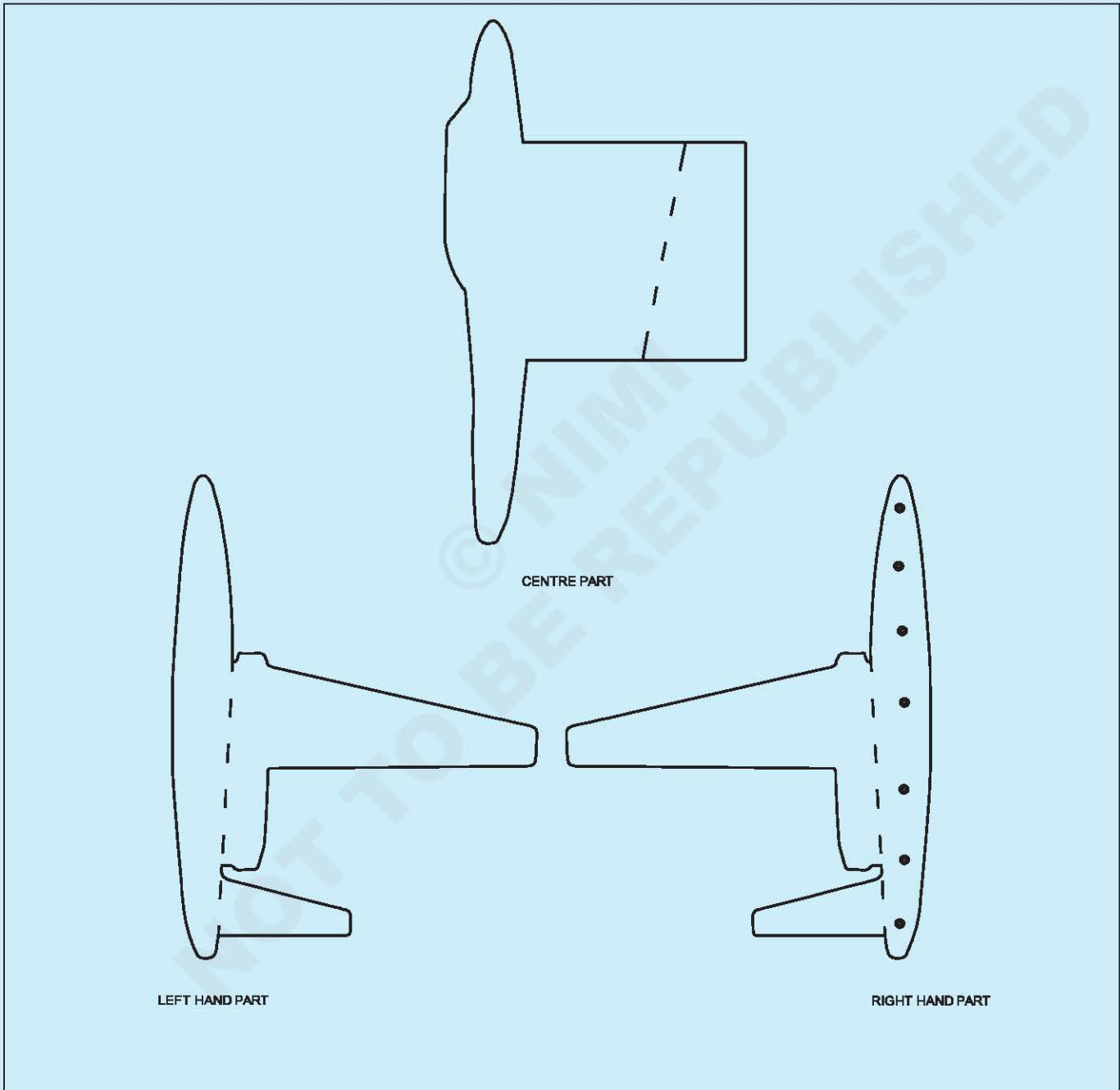

-	-	-	-	-	-	2.1.28
NO.OFF	STOCK SIZE	SEMI-PRODUCT	MATERIAL	PROJECT NO.	PART NO.	EX. NO.
SCALE: NTS	PART MANUFACTURING LITTLE BENDED AIRCRAFT 2				DEVIATIONS	TIME: 20HRS
					CODE NO : AFN2128E1	

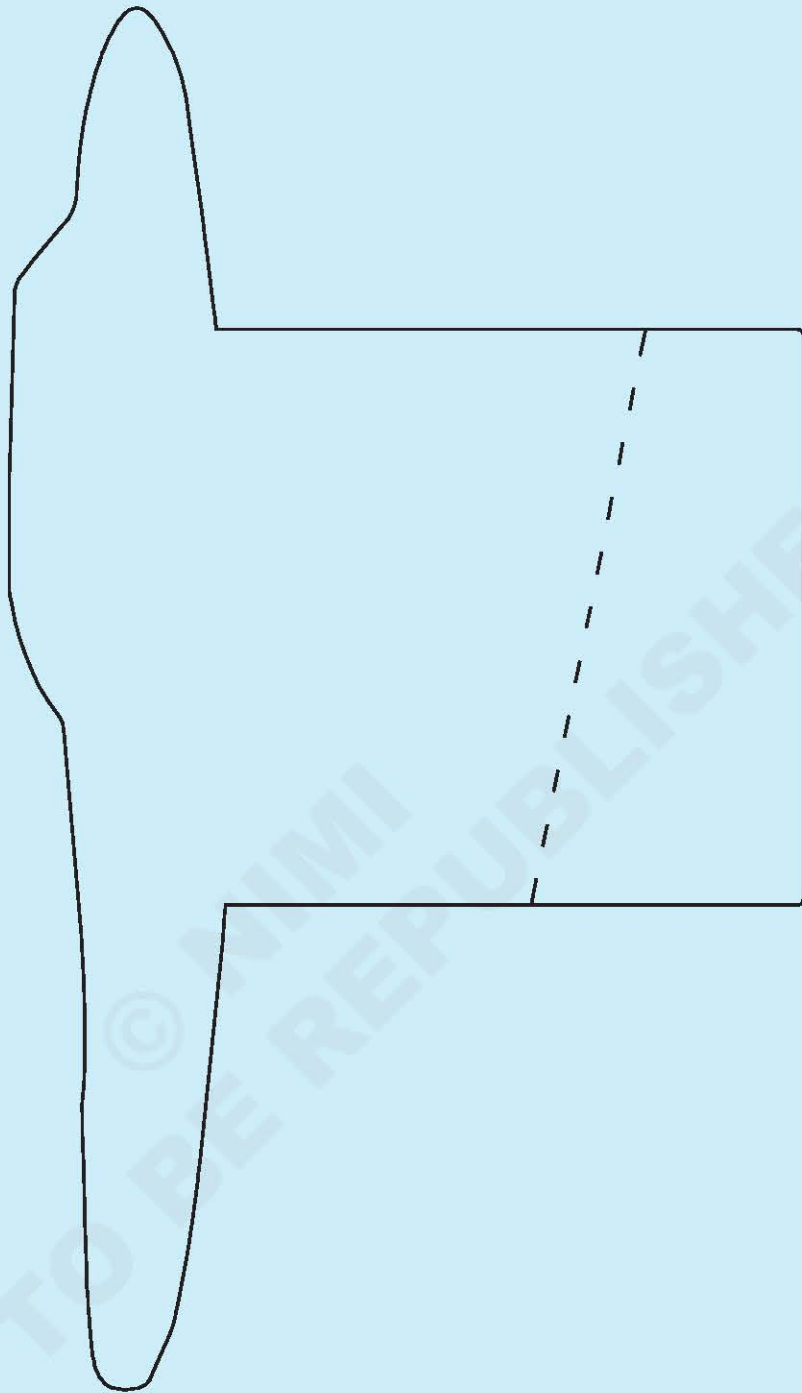

MATERIAL: 5086
 THICKNESS: 2MM
 DASHED LINE IS THE BENDING LINE

© NIMI
 NOT TO BE RE-PUBLISHED

1	100 X 180 2MM	-	AW-5086	-	-	2.1.28
NO.OFF	STOCK SIZE	SEMI-PRODUCT	MATERIAL	PROJECT NO.	PART NO.	EX. NO.
SCALE: NTS	LITTLE BENDED AIRCRAFT 2 TEMPLATE CENTRE PART				DEVIATIONS	TIME: 20HRS
					CODE NO : AFN2128E2	

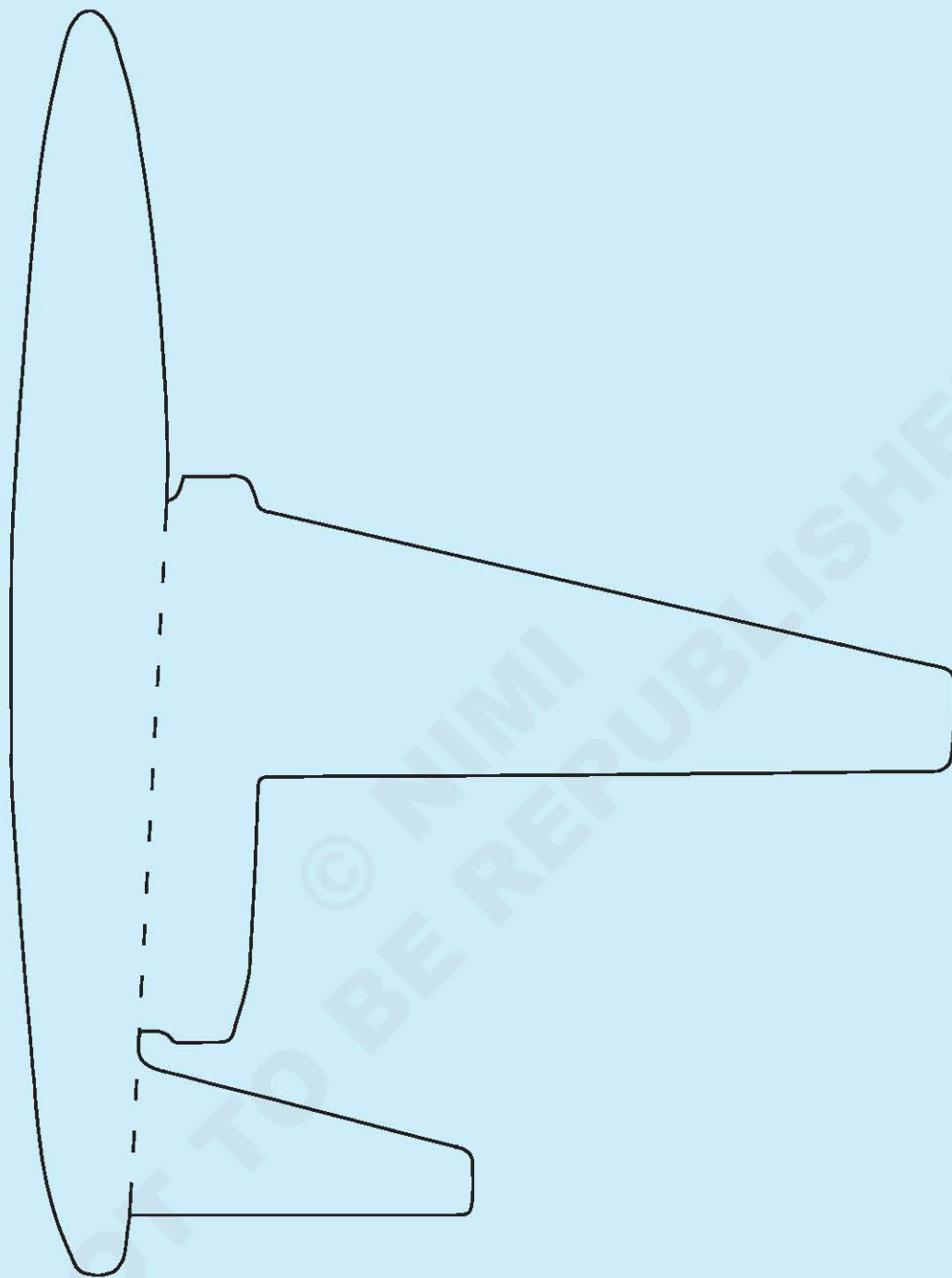

MATERIAL: 5086
THICKNESS: 1.5 MM

1	100 X 180 - 1.5MM	-	AW-5086	-	-	2.1.28
NO.OFF	STOCK SIZE	SEMI-PRODUCT	MATERIAL	PROJECT NO.	PART NO.	EX. NO.
SCALE: NTS	LITTLE BENDED AIRCRAFT 2 TEMPLATE LH PART				DEVIATIONS	TIME: 20HRS
					CODE NO : AFN2128E3	

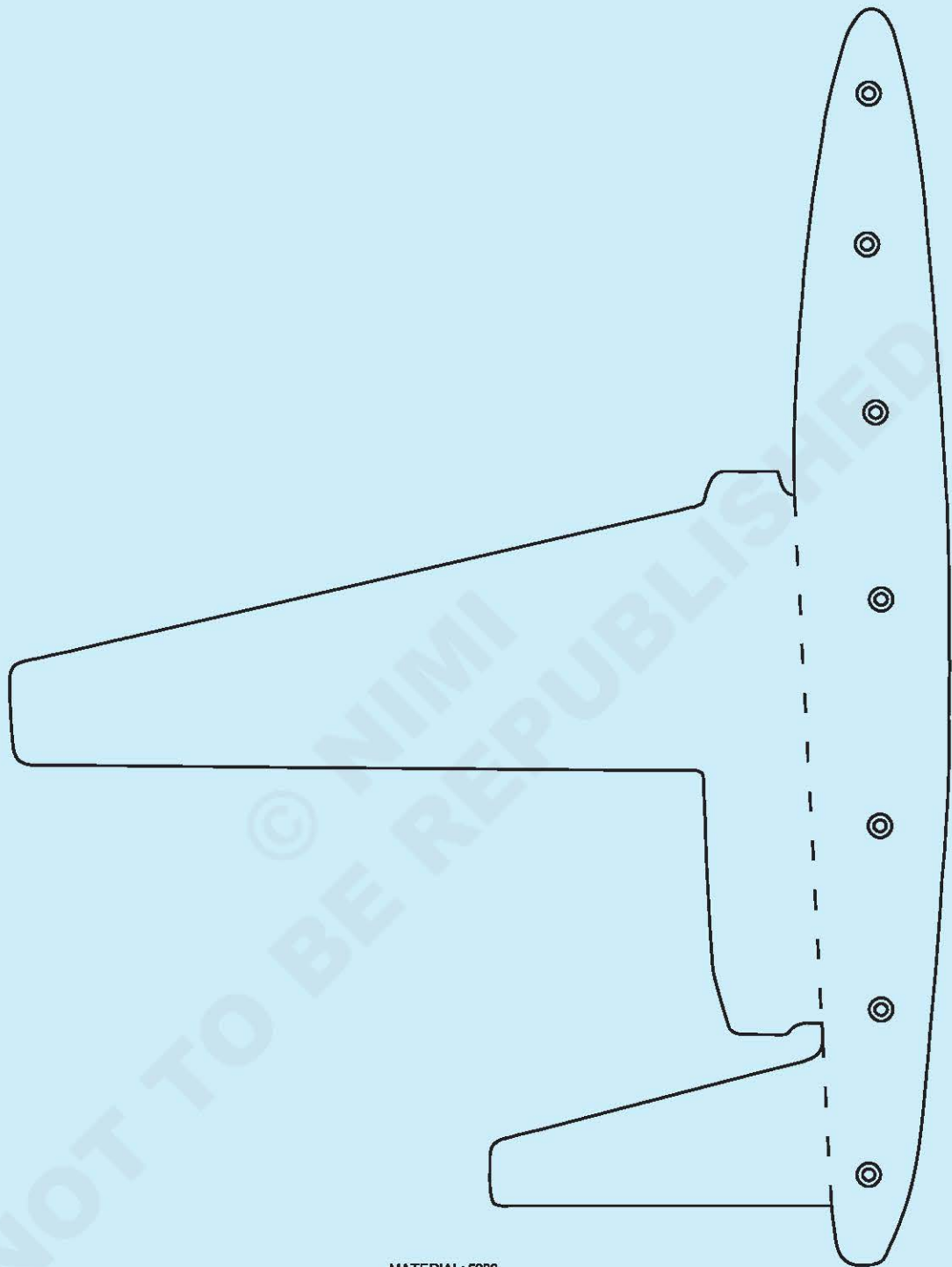

MATERIAL: 5086
 THICKNESS: 1.5 MM
 DRILL HOLES DIAMETER 2.5MM

1	100 X 180 - 1.5MM	-	AW-5086	-	-	2.1.28
NO.OFF	STOCK SIZE	SEMI-PRODUCT	MATERIAL	PROJECT NO.	PART NO.	EX. NO.
SCALE: NTS		LITTLE BENDED AIRCRAFT 2 TEMPLATE RH PART			DEVIATIONS	TIME: 20HRS
					CODE NO : AFN2128E4	

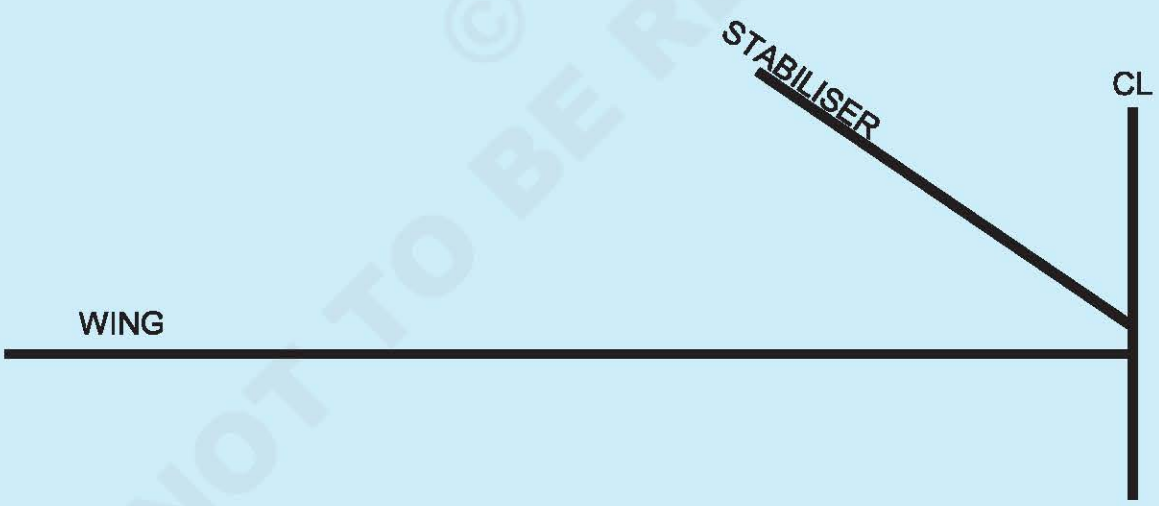
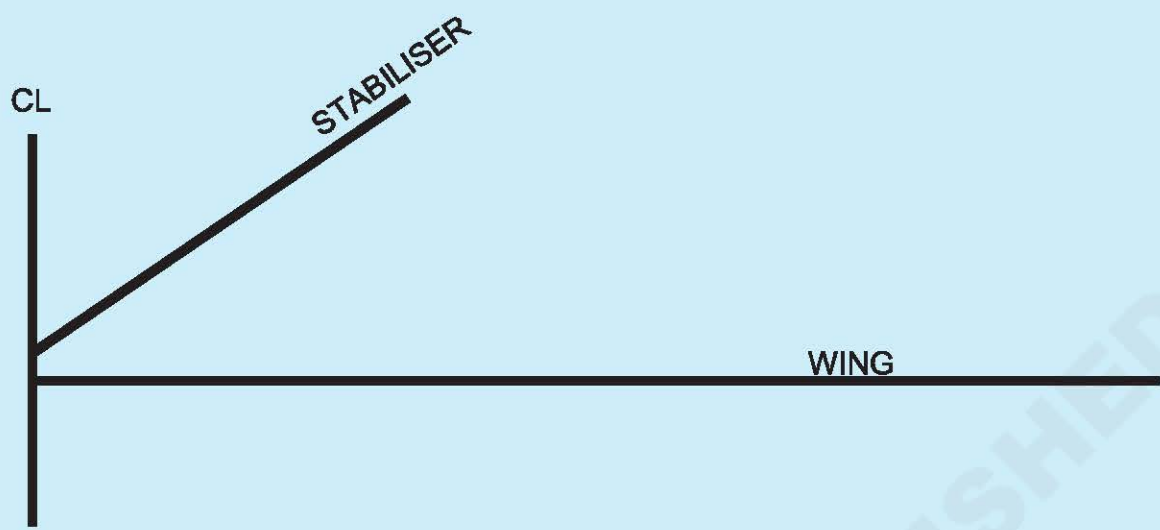

BENDING IN DASHED LINES
 ANGLE: 90°
 RADIUS SEE THE TABLE OF RADIUS BENDING

--	--	--	-	-	--	2.1.28
NO.OFF	STOCK SIZE	SEMI-PRODUCT	MATERIAL	PROJECT NO.	PART NO.	EX. NO.
SCALE: NTS		LITTLE BENDED AIRCRAFT 2 BENDING RH AND LH PART			DEVIATIONS	TIME: 20HRS
					CODE NO : AFN2128E5	

PROCEDURE

TASK 1: Centre part manufacturing

Tracing

- Trace the outline of the profile of each part, using tracing paper.

Punching the profile contour

- On the workpiece, point with a punch the contour of the central part.

Cutting and filing

- Cut with a saw as close as possible to the line.
- Adjust and control by comparison with the original profile
- Deburr accurately.



TASK 2: Right part manufacturing

Tracing

Trace the outline of the profile of each part, using tracing paper.

Punching the profile contour

- On the workpiece, point with a punch the contour of the central part.

Cutting and filing

- Cut with a saw as close as possible to the line.
- Adjust and control by comparison with the original profile.
- Deburr accurately.



TASK 3: Left part manufacturing

Tracing

- Trace the outline of the profile of each part, using tracing paper.

Punching the profile contour

- On the workpiece, point with a punch the contour of the central part.

- Adjust and control by comparison with the original profile.
- Deburr accurately.

Drilling

- Punch the centre of the holes.
- Drill to 2.5 mm diameter.

Cutting and filing

- Cut with a saw as close as possible to the line.



TASK 4: Pre-assembly

- Put the three parts together in the following order:
 - Left part.
 - Centre part.
 - Right part.

The edges must match.

- Hold with clamps.

- Counter-drill existing holes.
- Clamp at each hole.

If necessary, file to ensure that the edges are flush.

- Mark the left and right parts with pencil.
- Disassemble and deburr.



TASK 5: Bending

Bending of the centre part

- Using a brake, bend the two elements according to the dotted lines of the template. Angle 90°.

NOTE

The left and right parts are symmetrical.

The bend angles are shown on the “ **BENDING RH AND LH PARTS** ” drawing (sheet 4).

Bending of the left part

- Using a brake, bend the two elements according to the dotted lines of the template.

Caution

As the bends are misaligned, take care to choose the bending point without damage the piece.

Bending of the right part

- Using a brake, bend the two elements according to the dotted lines of the template.

Caution

As the bends are misaligned, take care to choose the bending point without damage the piece.

TASK 6: Riveting

NOTE:

The rivets to be used are 2.4 mm (3/32”) diameter, aluminium 2117, universal head.

- Clamp the three parts together with clamps.

Clamping rate of 50%.

- Calculate rivet lengths.
- Prepare the riveting squeezer with rivet sets.
- Rivet unclamped holes.
- Remove the pins and rivet the other holes.

Part manufacturing - little fuselage - Task 1

Objectives: At the end of this exercise you shall be able to

- manufacture part following drawing
- calculate length developed for bending
- calculate length developed for rolling.

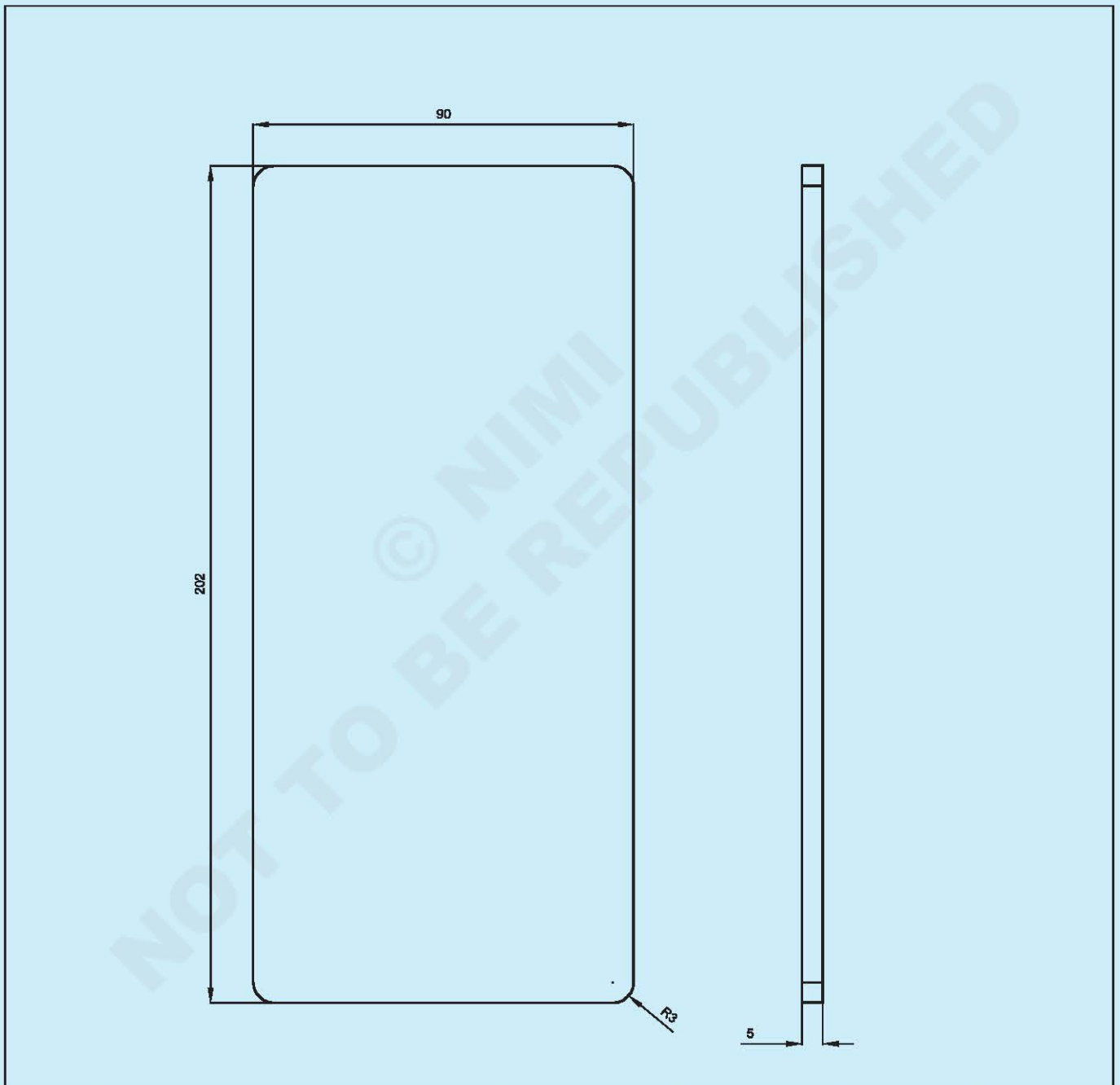

1	202 X 90 X 5MM	-	AW - 2017	-	--	2.1.29
NO.OFF	STOCK SIZE	SEMI-PRODUCT	MATERIAL	PROJECT NO.	PART NO.	EX. NO.
SCALE: NTS	PART MANUFACTURING - LITTLE FUSELAGE ITEM 01 - BASE				DEVIATIONS	TIME: 20HRS
					CODE NO : AFN2129E1	

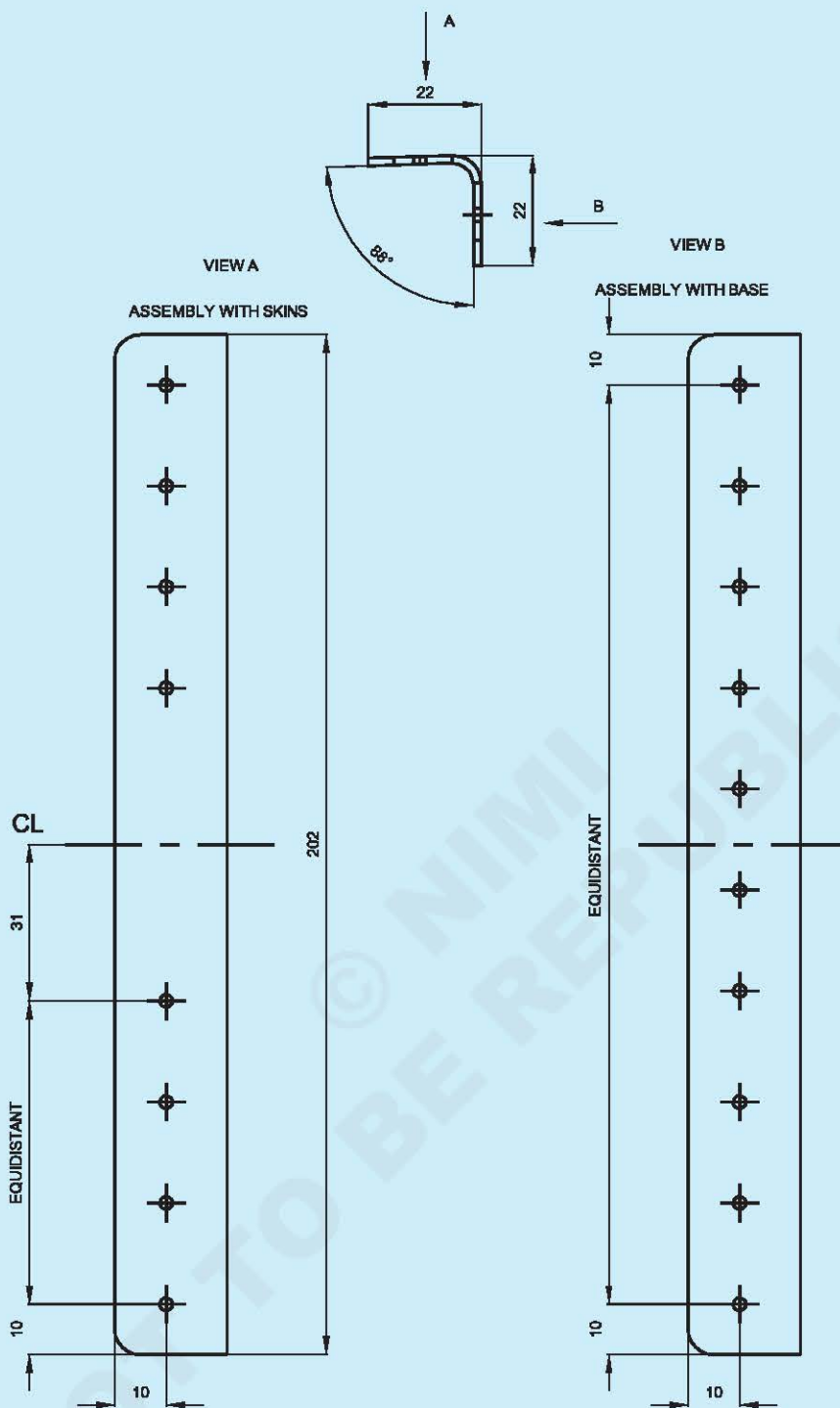

1	205 X 50 - 1.5MM	--	AW - 5086	-	-	2.1.29
NO.OFF	STOCK SIZE	SEMI-PRODUCT	MATERIAL	PROJECT NO.	PART NO.	EX. NO.
SCALE: NTS	PART MANUFACTURING - LITTLE FUSELAGE ITEM 02 - LOWER ANGLE				DEVIATIONS	TIME: 20HRS
					CODE NO : AFN2129E2	

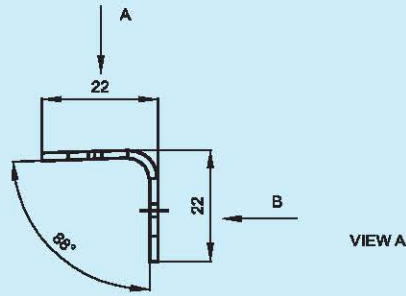

VIEW A

VIEW A

ASSEMBLY WITH SKINS

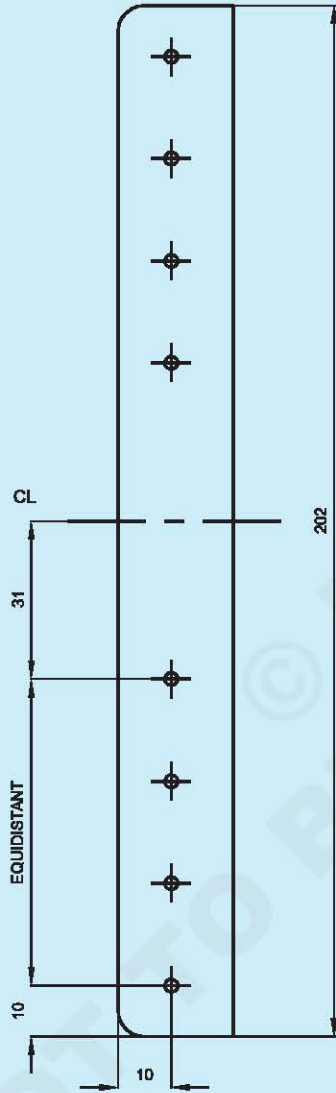

1	205 X 50 - 1.5MM	--	AW - 5086	--	-	2.1.39
NO.OFF	STOCK SIZE	SEMI-PRODUCT	MATERIAL	PROJECT NO.	PART NO.	EX. NO.
SCALE: NTS		PART MANUFACTURING - LITTLE FUSELAGE ITEM 03 - UPPER ANGLE			DEVIATIONS	TIME: 20HRS
					CODE NO : AFN2139E3	

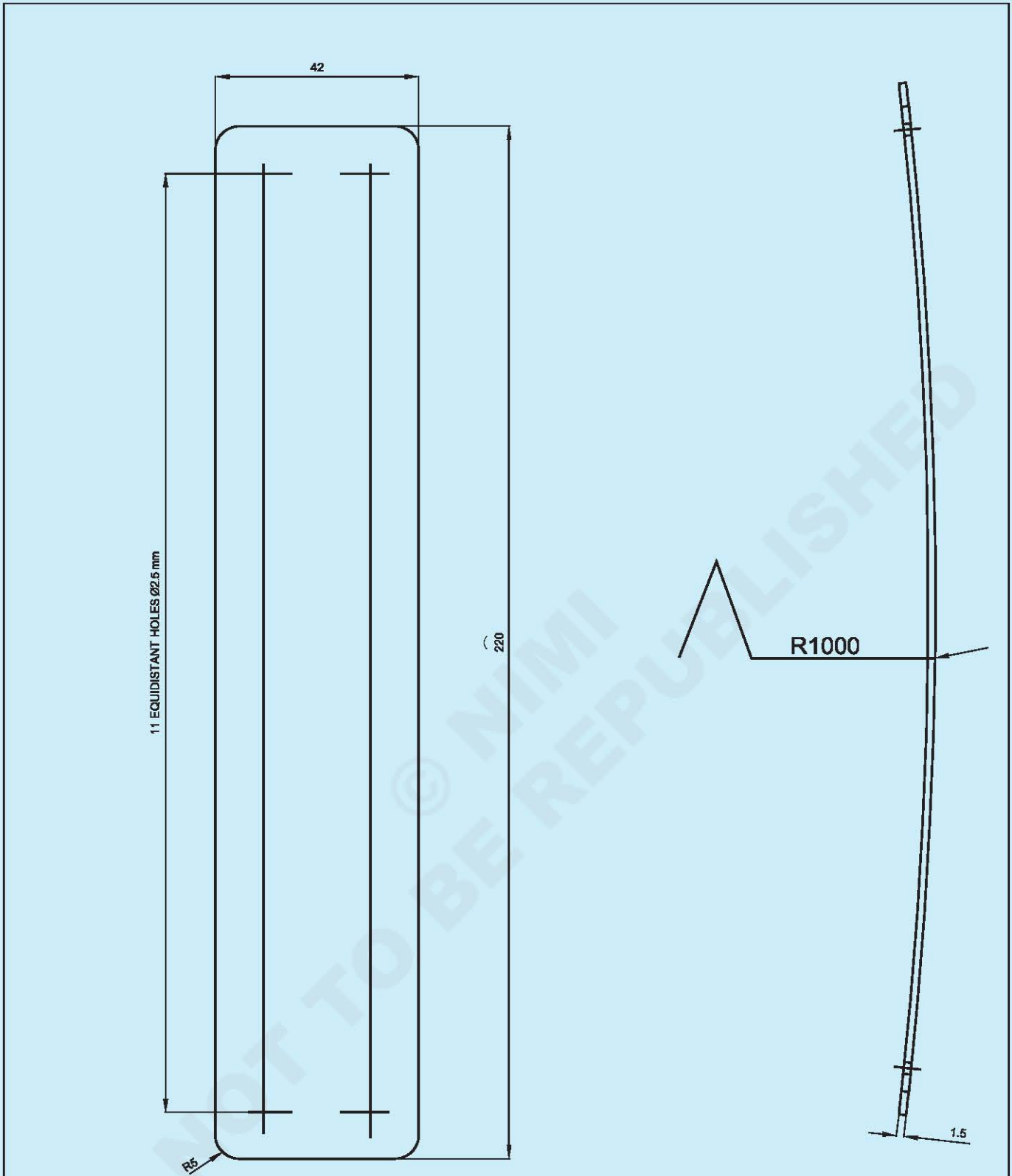

EDGE DISTANCE: 10MM

1	205 X 40 - 1.5MM	-	AW - 2024	-	-	2.1.29
NO.OFF	STOCK SIZE	SEMI-PRODUCT	MATERIAL	PROJECT NO.	PART NO.	EX. NO.
SCALE: NTS		PART MANUFACTURING - LITTLE FUSELAGE ITEM 04 - LAP JOINT			DEVIATIONS	TIME: 20HRS
					CODE NO : AFN2129E4	

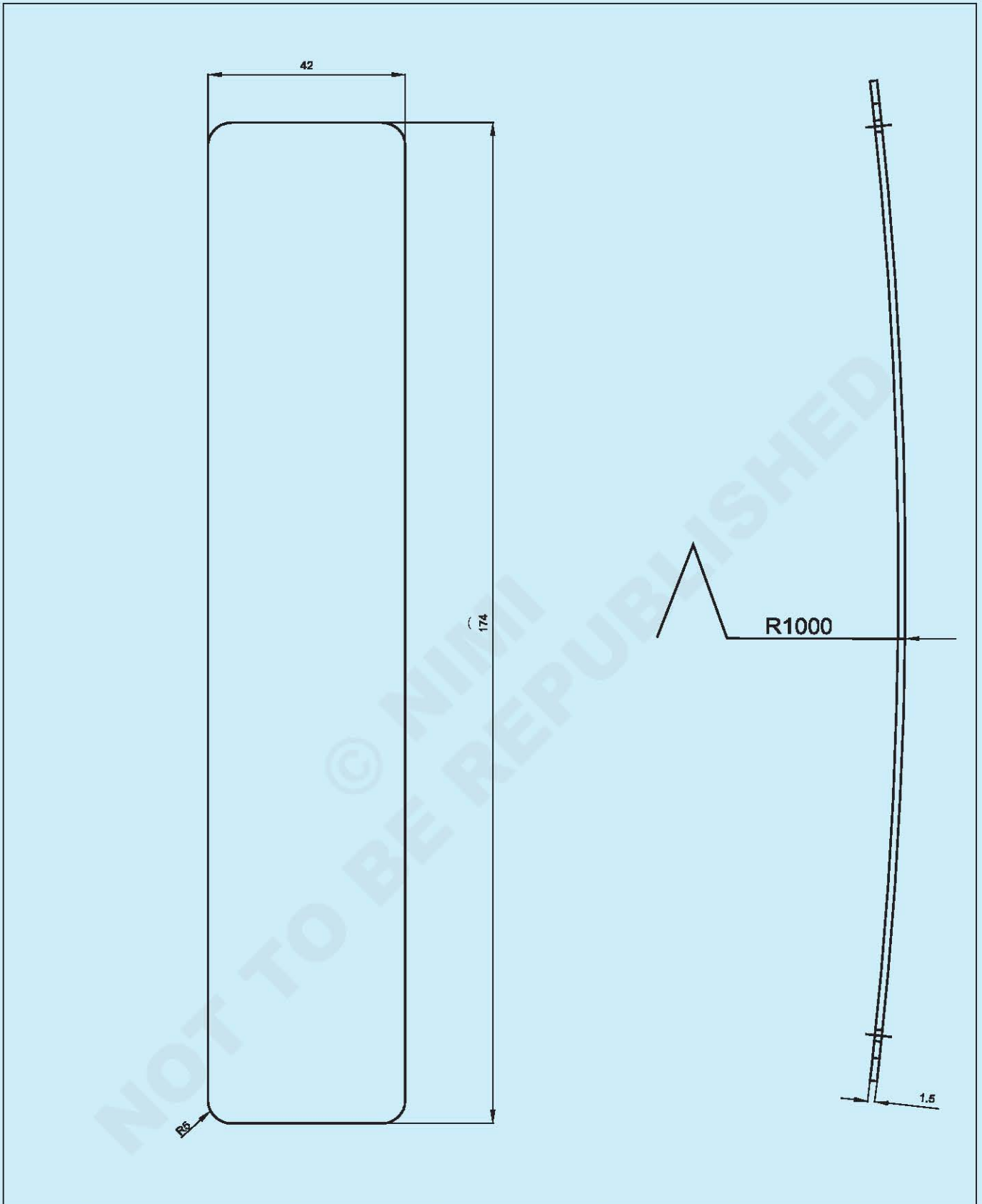

1	175 X 40	-	AW - 2024	--	-	2.1.29
NO.OFF	STOCK SIZE	SEMI-PRODUCT	MATERIAL	PROJECT NO.	PART NO.	EX. NO.
SCALE: NTS		PART MANUFACTURING - LITTLE FUSELAGE ITEM 05 - SHIM			DEVIATIONS	TIME: 20HRS
					CODE NO : AFN2129E5	

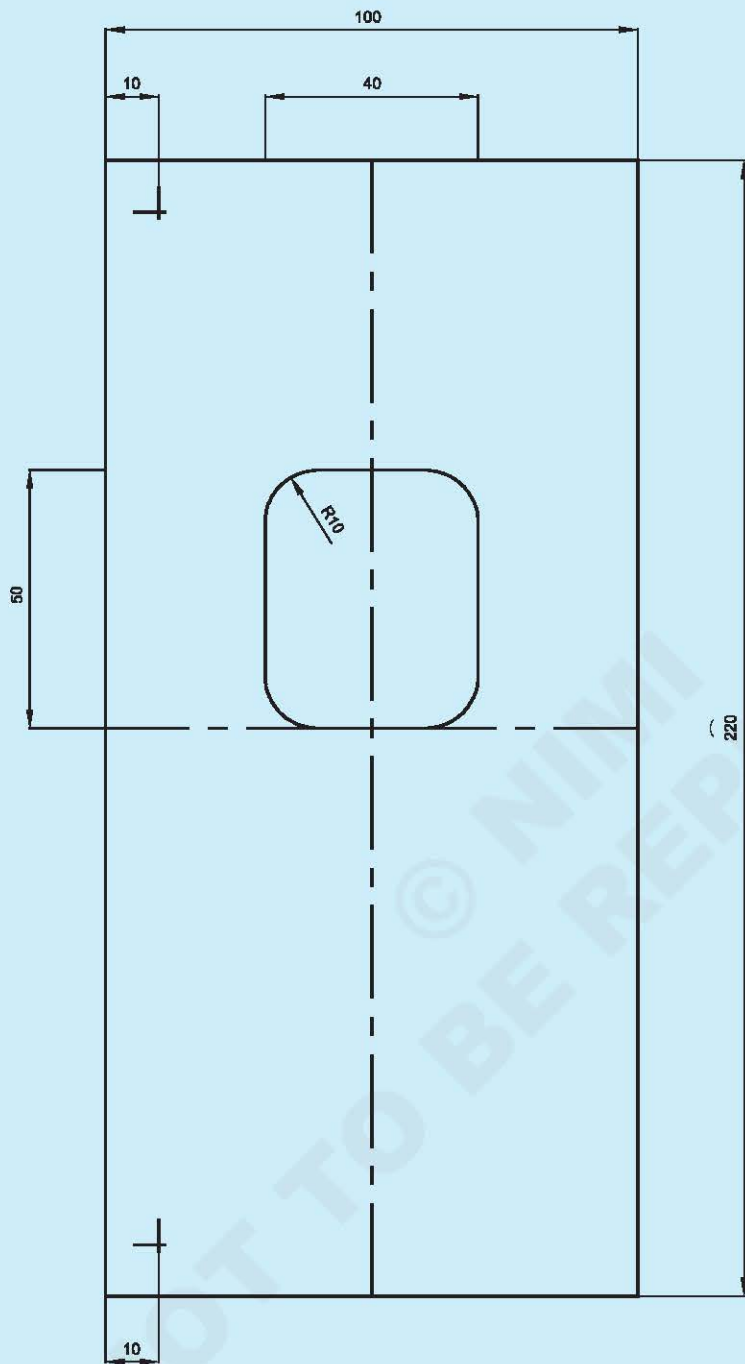

Forward part viewed
Rear part symmetrical

1	100 X 220 - 2MM	-	AW - 2024	--	-	2.1.29
NO.OFF	STOCK SIZE	SEMI-PRODUCT	MATERIAL	PROJECT NO.	PART NO.	EX. NO.
SCALE: NTS		PART MANUFACTURING - LITTLE FUSELAGE ITEM 06 - SKIN			DEVIATIONS	TIME: 20HRS
					CODE NO : AFN2129E6	

PROCEDURE

MANUFACTURING ITEM 01 – BASE

- Check dimensions and thickness.
- Mark and file external dimensions.
- Mark and file radii.
- Finish edges by draw filing.
- Deburr edges.

Check the part and complete the report sheet at the end of the work order.

MANUFACTURING ITEM 02 – LOWER ANGLE

- Check dimensions and thickness.
- Calculate the developed length.
- Mark and file external dimensions calculated above.
- Finish edges by draw filing.
- Deburr edges.
- Bend the angle using brake.
- Check the angle and the dimensions of flanges. File if necessary.
- Mark and file radii.
- Mark the holes positions.
- Punch the centre of the holes.

Drilling diameter 2.5

- Hold the workpiece and drill holes with hand drill.
- Deburr both sides.
- Check diameter and perpendicularity of each hole.

Check the part and complete the report sheet at the end of the work order.

MANUFACTURING ITEM 03 – UPPER ANGLE

- Check dimensions and thickness.
- Calculate the developed length.
- Mark and file external dimensions calculated above.
- Finish edges by draw filing.
- Deburr edges.
- Bend the angle using brake.
- Check the angle and the dimensions of flanges. File if necessary.
- Mark and file radii.
- Mark the holes positions.
- Punch the centre of the holes.

Drilling diameter 2.5

- Hold the workpiece and drill holes with hand drill.
- Deburr both sides.
- Check diameter and perpendicularity of each hole.

Check the part and complete the report sheet at the end of the work order.

MANUFACTURING ITEM 04 – LAP JOINT

- Check dimensions and thickness.
- Calculate the developed length.
- Mark the dimensions calculated above.
- File the width (42 mm)
- Finish edges by draw filing.
- Deburr edges.
- Roll the workpiece using rolling machine.
- Check the radius of rolling and the dimensions. File if necessary.
- Mark and file radii.
- Mark the holes positions.
- Punch the centre of the holes.

Drilling diameter 2.5

- Hold the workpiece and drill holes with hand drill.

Drilling diameter 20

- Deburr both sides.
- Check diameter and perpendicularity of each hole.

Check the part and complete the report sheet at the end of the work order.

MANUFACTURING ITEM 05 – SHIM

- Check dimensions and thickness.
- Calculate the developed length.
- Mark the dimensions calculated above.
- File the width (42 mm)
- Finish edges by draw filing.
- Deburr edges.
- Roll the workpiece using rolling machine.
- Check the radius of rolling and the dimensions. File if necessary.
- Mark and file radii.

Check the part and complete the report sheet at the end of the work order.

MANUFACTURING ITEM06 - SKINS

NOTE: Two symmetrical parts must be manufactured.

- Check dimensions and thickness.
- Calculate the developed length.
- Mark the dimensions calculated above.
- File the width (100 mm)
- Finish edges by draw filing.
- Deburr edges.
- Roll the workpiece using rolling machine.
- Check the radius of rolling and the dimensions. File if necessary.
- Mark the windows holes positions following these instructions (Fig 1)
- Mark the centre lines (A).
- Mark the centre of the radii R10 (B).
- Mark the limits of the cut (C).
- Punch the centre of the 4 holes.

Drilling diameter 2.5

- Hold the workpiece and drill holes with hand drill.

Drilling diameter 20

- Using hole saw, drill the four holes to obtain the radius 10 mm on each angle. (Fig 2)

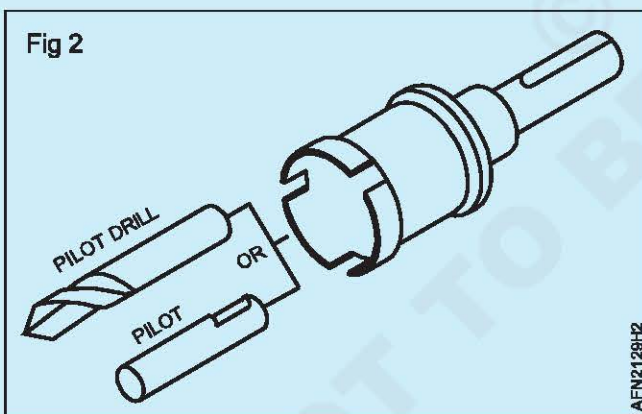

- Measure the diameter of the pilot.
- Drill to the previously measured diameter.
- Drill final diameter using hole saw.
- Deburr both sides.

It is also possible to use a step drill. (Fig 3)

- Using hacksaw, cut the sheet metal to open completely the window hole.
- File and deburr.

Check the part and complete the report sheet at the end of the work order.

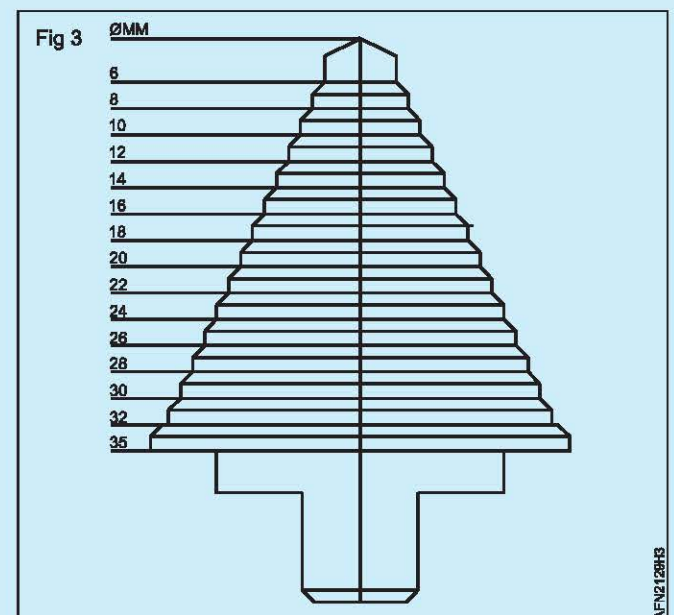
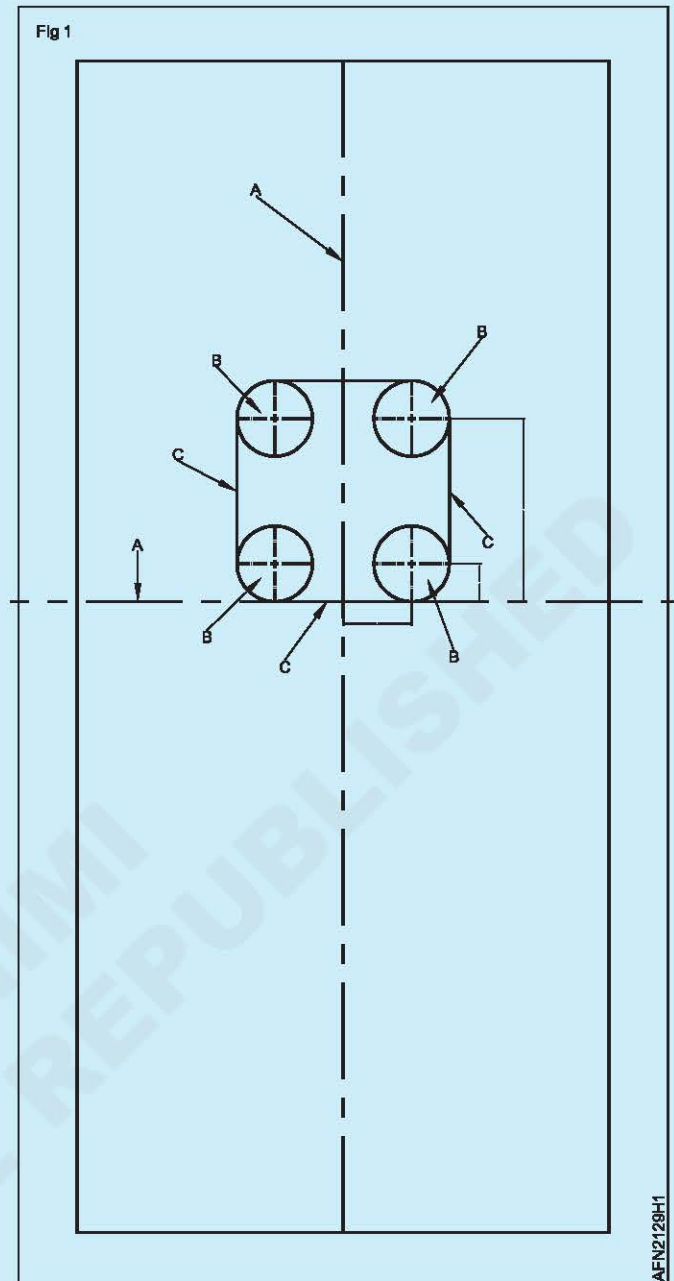

REPORT SHEET – ITEM 01 – BASE

Dimensions	Theoretical		Measured
External dimensions	202	±0.5	
	90	±0.5	
Radii	5	±0.5	
	5	±0.5	
	5	±0.5	
	5	±0.5	

Deburring quality

CONFORM

NOT CONFORM

Absence of marks, impacts or scratches

CONFORM

NOT CONFORM

REPORT SHEET – ITEM 02 – LOWER ANGLE

Dimensions	Theoretical		Measured
Length	202	±0.5	
Flanges	22	±0.5	
	22	±0.5	
Bending angle	88°	±1°	
Radii	5	±0.5	
	5	±0.5	
	5	±0.5	
	5	±0.5	

Drilling	Theoretical		Measured
Edge distance	10	+1 / -0	
Number of holes	18		
Drilling quality	-		<input type="checkbox"/> OK <input type="checkbox"/> NOK
Deburring quality	-		<input type="checkbox"/> OK <input type="checkbox"/> NOK

Deburring quality of the workpiece

CORRECT YES NO

Absence of marks, impacts or scratches

CORRECT YES NO

REPORT SHEET – ITEM 03 – UPPER ANGLE

Dimensions	Theoretical		Measured
Length	202	±0.5	
Flanges	22	±0.5	
	22	±0.5	
Bending angle	88°	±1°	
Radii	5	±0.5	
	5	±0.5	
	5	±0.5	
	5	±0.5	

Drilling	Theoretical		Measured
Edge distance	10	+1 / -0	
Number of holes	8		
Drilling quality	-		<input type="checkbox"/> OK <input type="checkbox"/> NOK
Deburring quality	-		<input type="checkbox"/> OK <input type="checkbox"/> NOK

Deburring quality of the workpiece

CORRECT YES NO

Absence of marks, impacts or scratches

CORRECT YES NO

REPORT SHEET – ITEM 04 – LAP JOINT

Dimensions	Theoretical		Measured
Length (arc)	220	±0.5	
Width	42	±0.5	
Rolling radius	1000	±5	
Radii	5	±0.5	
	5	±0.5	
	5	±0.5	
	5	±0.5	

Drilling	Theoretical		Measured
Edge distance	10	+1 / -0	
Number of holes	22		
Drilling quality	-		<input type="checkbox"/> OK <input type="checkbox"/> NOK
Deburring quality	-		<input type="checkbox"/> OK <input type="checkbox"/> NOK

Deburring quality of the workpiece

CORRECT YES NO

Absence of marks, impacts or scratches

CORRECT YES NO

Drilling (window)	Theoretical		Measured	
Radii	10	±1		
Height	40	±1		
Width	30	±1		
Centered in relation to vertical centre line			<input type="checkbox"/> OK	<input type="checkbox"/> NOK
Aligned above the centre line			<input type="checkbox"/> OK	<input type="checkbox"/> NOK
Filing quality	-		<input type="checkbox"/> OK	<input type="checkbox"/> NOK
Deburring quality	-		<input type="checkbox"/> OK	<input type="checkbox"/> NOK

Deburring quality of the workpiece CORRECT YES NO

Absence of marks, impacts or scratches CORRECT YES NO

© NIMI
NOT TO BE REPUBLISHED

Part manufacturing - little fuselage assembly

Objectives: At the end of this exercise you shall be able to

- position the parts following drawing
- drill and countersink holes
- Clamp parts with pins.

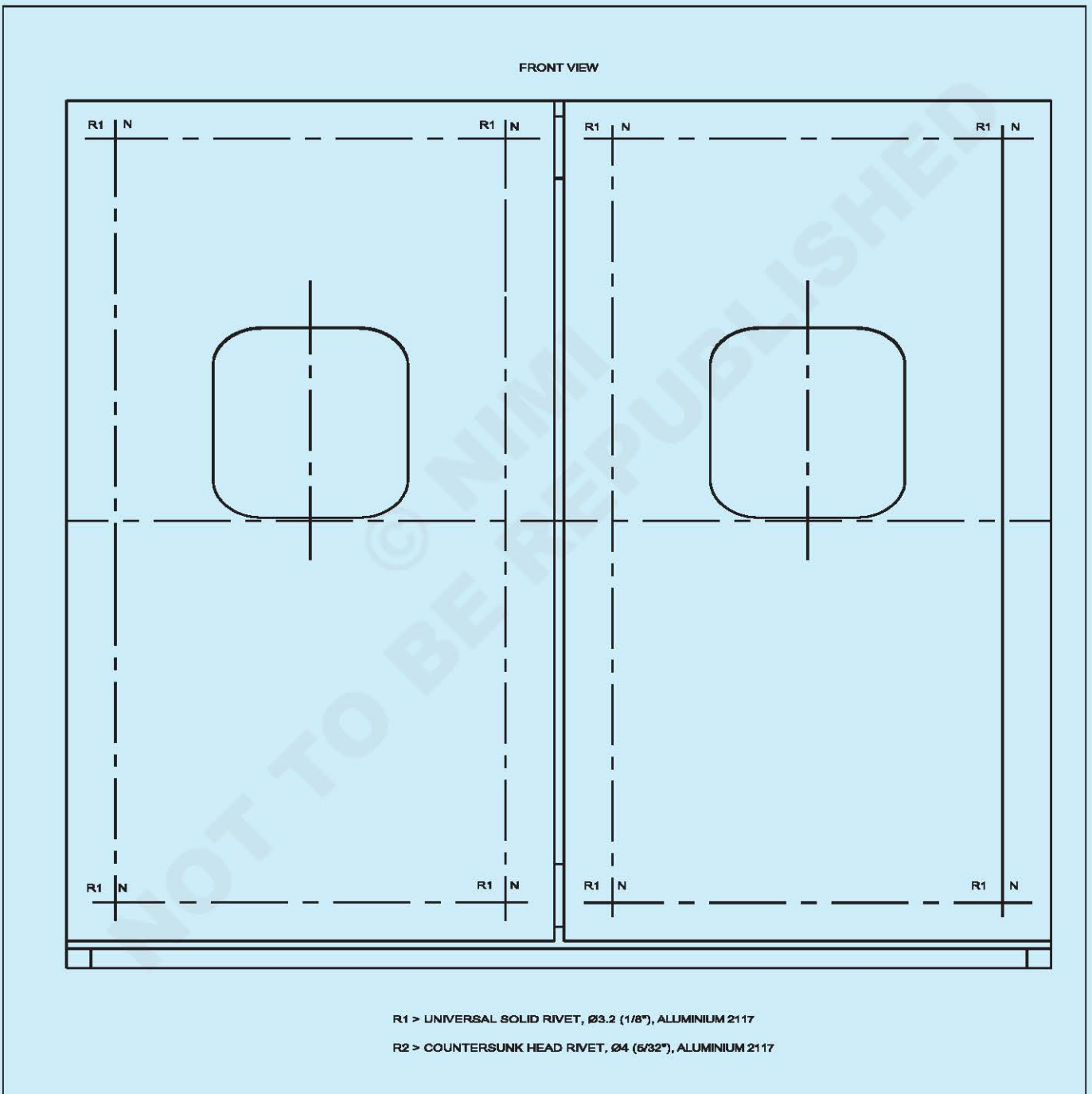

1	--	2.1.29	--	--	--	2.1.30
NO.OFF	STOCK SIZE	SEMI-PRODUCT	MATERIAL	PROJECT NO.	PART NO.	EX. NO.
SCALE: NTS 					DEVIATIONS TIME: 20HRS	CODE NO : AFN2130E1
PART ASSEMBLY - LITTLE FUSELAGE FRONT VIEW						

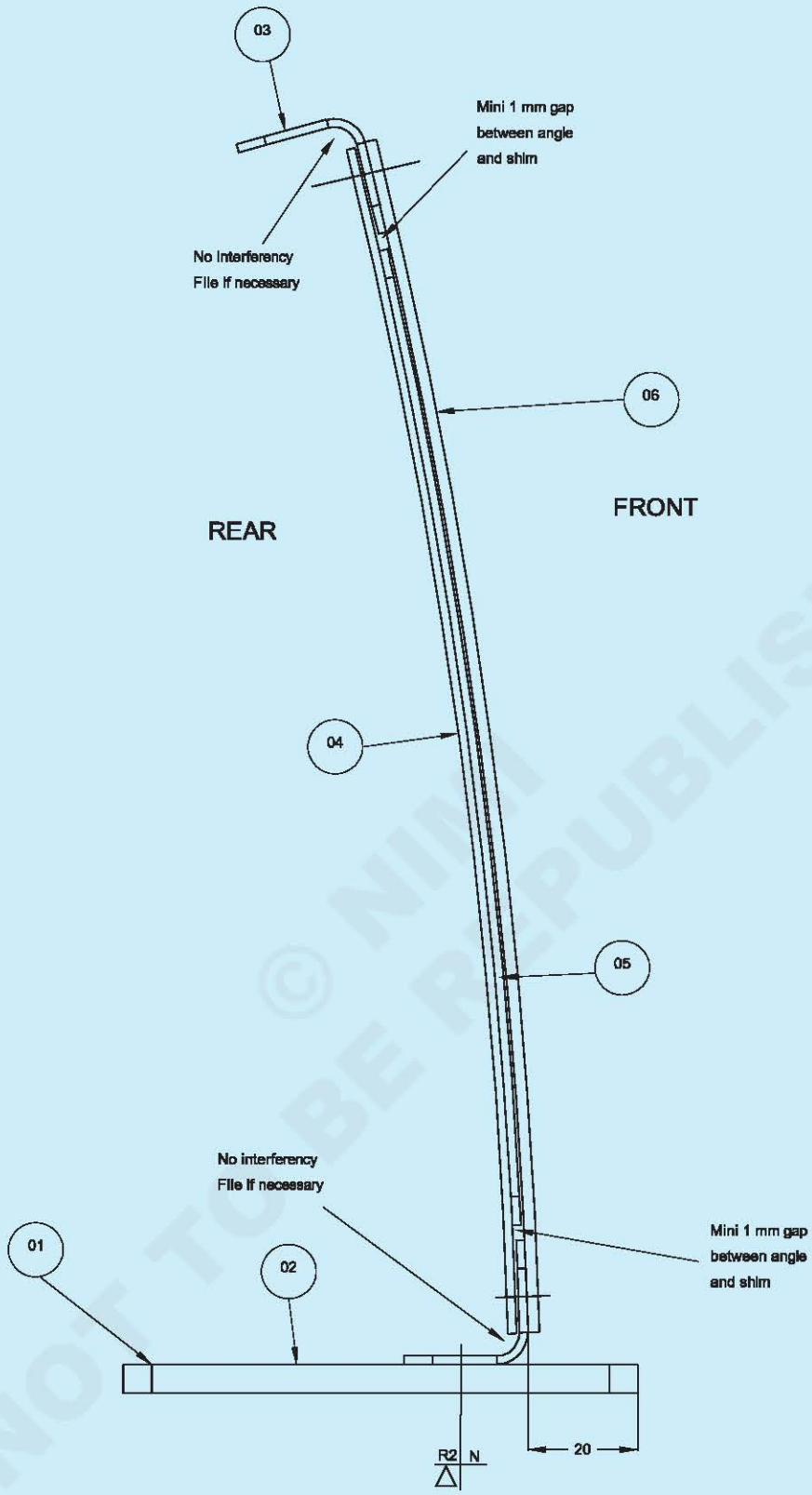

R1 > UNIVERSAL SOLID RIVET, Ø3.2 (1/8"), ALUMINIUM 2117
 R2 > COUNTERSUNK HEAD RIVET, Ø4 (5/32"), ALUMINIUM 2117

1	-	→ 2.1.29	--	--	-	2.1.30
NO.OFF	STOCK SIZE	SEMI-PRODUCT	MATERIAL	PROJECT NO.	PART NO.	EX. NO.
SCALE: NTS		PART ASSEMBLY - LITTLE FUSELAGE LATERAL VIEW			DEVIATIONS	TIME: 20HRS
					CODE NO : AFN2130E2	

Job Sequence

Assembly of the lower angle with the base.

- Place the item 2 (lower angle) on item 1 (base) according to the 20 mm dimension.
- For easier positioning:
- Use a square to ensure perpendicularity.
- Use a V block to ensure flush.
- Use a depth calliper to ensure dimension.
- Lock with clamps.
- Counter-drill holes, clamping as you go (Diameter 2.5 mm).
- Check for accurate positioning.
- Disassemble and deburr.
- Reassemble by clamping. (Pin rate: 50%).

Assembly of the skins on the bottom angle.

- Position one of the two skin panels, item 06, with the lower angle with a pin (see Figure 1.A).
- In the same way, position the other panel on the lower angle with a pin (see figure 1.B).

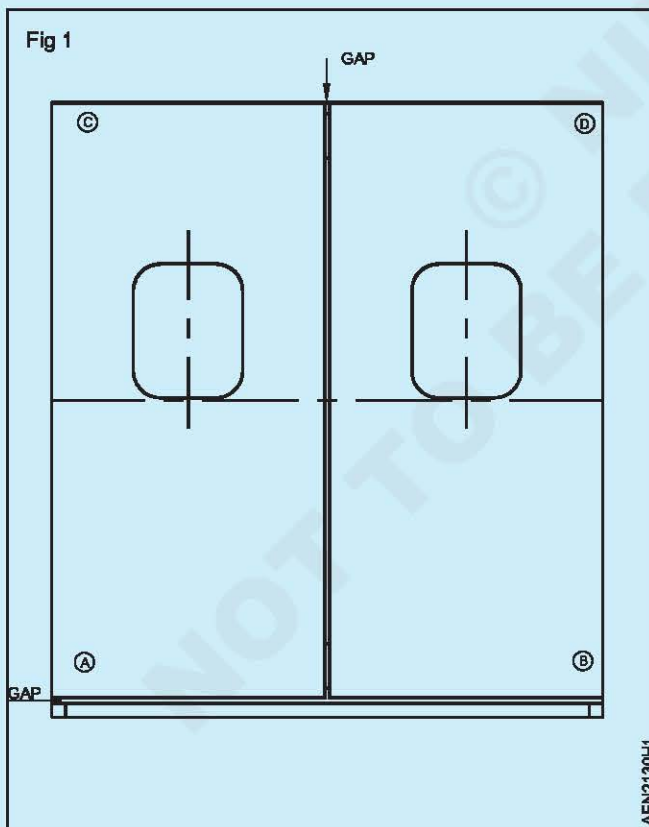

- Position the upper angle with the two skin panels and pin the two holes (see figure 1.C and D).
- Set a regular gap at the bottom with the base (item 01) and a regular gap between the two panels.
- Lock in position with clamps.
- Counter-drill an additional hole at the bottom and top of the angles towards the skin panels and clamp in place.
- Check that the assembly has remained in position.
- If the positioning is correct, counter-drill the other holes.

Assembly of the lap joint and the shim.

- On the shim, mark the centre line.
- Put double-sided tape on the convex surface of the shim, leaving the centre line visible.
- Using double-sided tape, position the shim:
- By centring the marking in the centre of the gap between the two skins.
- Ensuring the gaps with the upper and lower angles. (If necessary, file the length of the shim).
- Press in order to fix the shim in position.
- Place the lap joint in position.
- Check the gaps with the angles. Adjust if necessary.
- Lock in position with clamps.
- Counter-drill 6 holes (2 on the top, 2 in the centre and 2 at the bottom) and pin to hold in position.
- Check that the assembly has stayed in position.
- If the positioning is correct, counter-drill the other holes.

Counter drilling to final diameter

- Following the indications in the drawing and the designations of the rivets, counter-drill to the final diameter.
- Countersink the holes for countersunk head rivets.
- Mark all parts with pencil markings to facilitate later reassembly.
- Dismantle all parts.
- Deburr all holes.
- Reassemble all parts with a pin rate of 50%.
- Ask the instructor to check.
- Store the assembly.

REPORT SHEET

Deburring quality of the workpiece	CORRECT	<input type="checkbox"/> YES	<input type="checkbox"/> NO
Absence of marks, impacts or scratches	CORRECT	<input type="checkbox"/> YES	<input type="checkbox"/> NO
Lower angle position			
• 20 mm ± 0.5	CORRECT	<input type="checkbox"/> YES	<input type="checkbox"/> NO
Drilling for universal head rivet			
• Diameter	CORRECT	<input type="checkbox"/> YES	<input type="checkbox"/> NO
• Perpendicularity	CORRECT	<input type="checkbox"/> YES	<input type="checkbox"/> NO
• Circularity	CORRECT	<input type="checkbox"/> YES	<input type="checkbox"/> NO
• Deburring	CORRECT	<input type="checkbox"/> YES	<input type="checkbox"/> NO
Drilling for countersunk head rivet			
• Diameter	CORRECT	<input type="checkbox"/> YES	<input type="checkbox"/> NO
• Perpendicularity	CORRECT	<input type="checkbox"/> YES	<input type="checkbox"/> NO
• Circularity	CORRECT	<input type="checkbox"/> YES	<input type="checkbox"/> NO
• Deburring	CORRECT	<input type="checkbox"/> YES	<input type="checkbox"/> NO
Gap with the base (item 01)	CORRECT	<input type="checkbox"/> YES	<input type="checkbox"/> NO
Gap between skins	CORRECT	<input type="checkbox"/> YES	<input type="checkbox"/> NO
Clearance between shim and lower angle	CORRECT	<input type="checkbox"/> YES	<input type="checkbox"/> NO
Clearance between shim and upper angle	CORRECT	<input type="checkbox"/> YES	<input type="checkbox"/> NO
Clearance between lap joint and lower angle	CORRECT	<input type="checkbox"/> YES	<input type="checkbox"/> NO
Clearance between lap joint and upper angle	CORRECT	<input type="checkbox"/> YES	<input type="checkbox"/> NO

Riveting using rivet gun - Training

Objectives: At the end of this exercise you shall be able to

- rivet the part by using rivet gun.

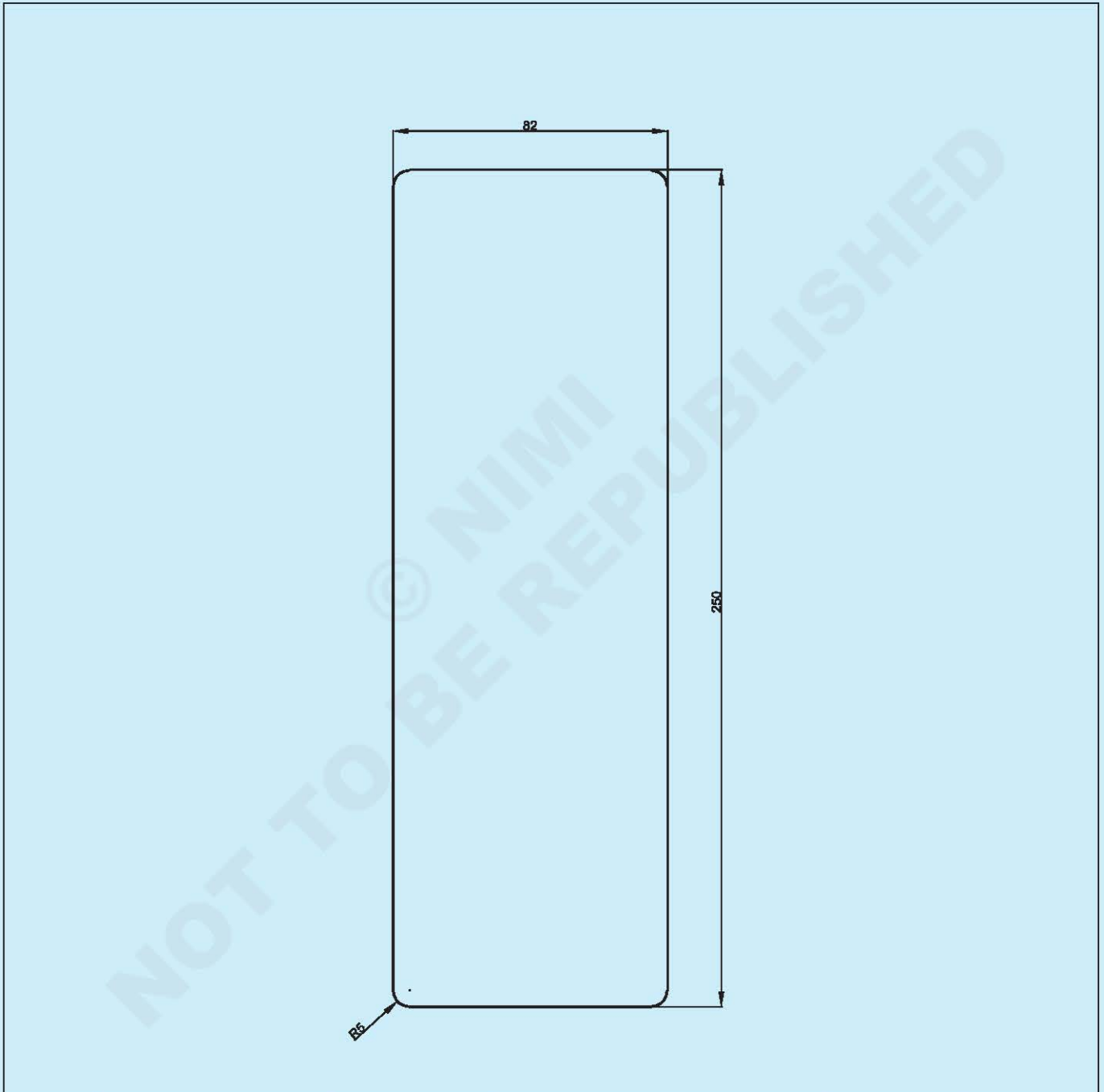

1	250 X 82 - 2MM	--	AW - 2024	-	--	2.1.31
NO.OFF	STOCK SIZE	SEMI-PRODUCT	MATERIAL	PROJECT NO.	PART NO.	EX. NO.
SCALE: NTS	RIVET GUN RIVETING MANUFACTURE ITEM 01				DEVIATIONS	TIME: 20HRS
					CODE NO : AFN2131E1	

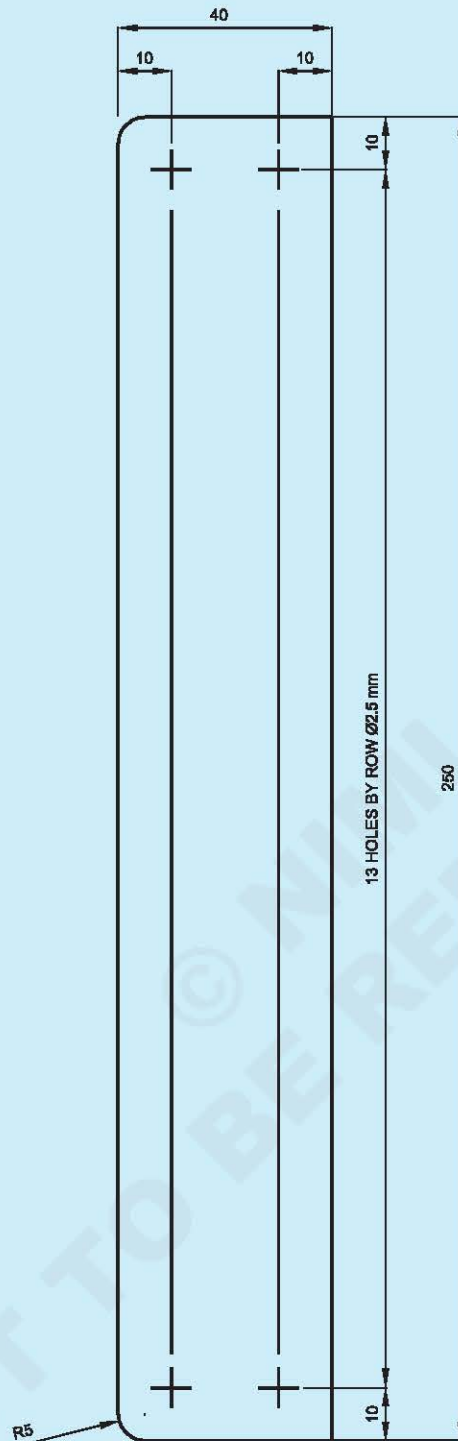

1	250 X 40 - 2MM	-	AW - 2024	-	--	2.1.31
NO.OFF	STOCK SIZE	SEMI-PRODUCT	MATERIAL	PROJECT NO.	PART NO.	EX. NO.
SCALE: NTS	RIVET GUN RIVETING MANUFACTURE ITEM 02				DEVIATIONS	TIME: 20HRS
					CODE NO : AFN2131E2	

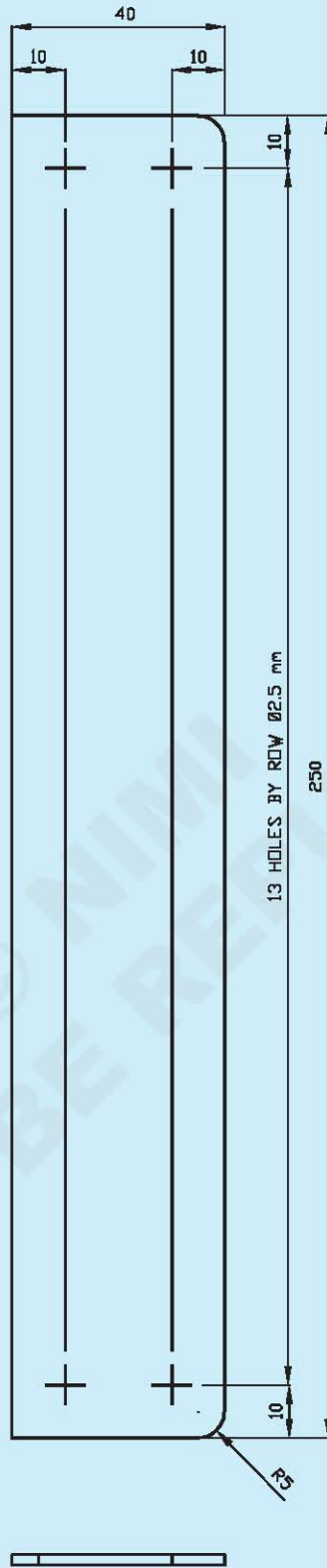

1	250 X 40 - 2MM	--	AW - 2024	-	-	2.1.31
NO.OFF	STOCK SIZE	SEMI-PRODUCT	MATERIAL	PROJECT NO.	PART NO.	EX. NO.
SCALE: NTS	RIVET GUN RIVETING MANUFACTURE ITEM 03				DEVIATIONS	TIME: 20HRS
					CODE NO : AFN2131E3	

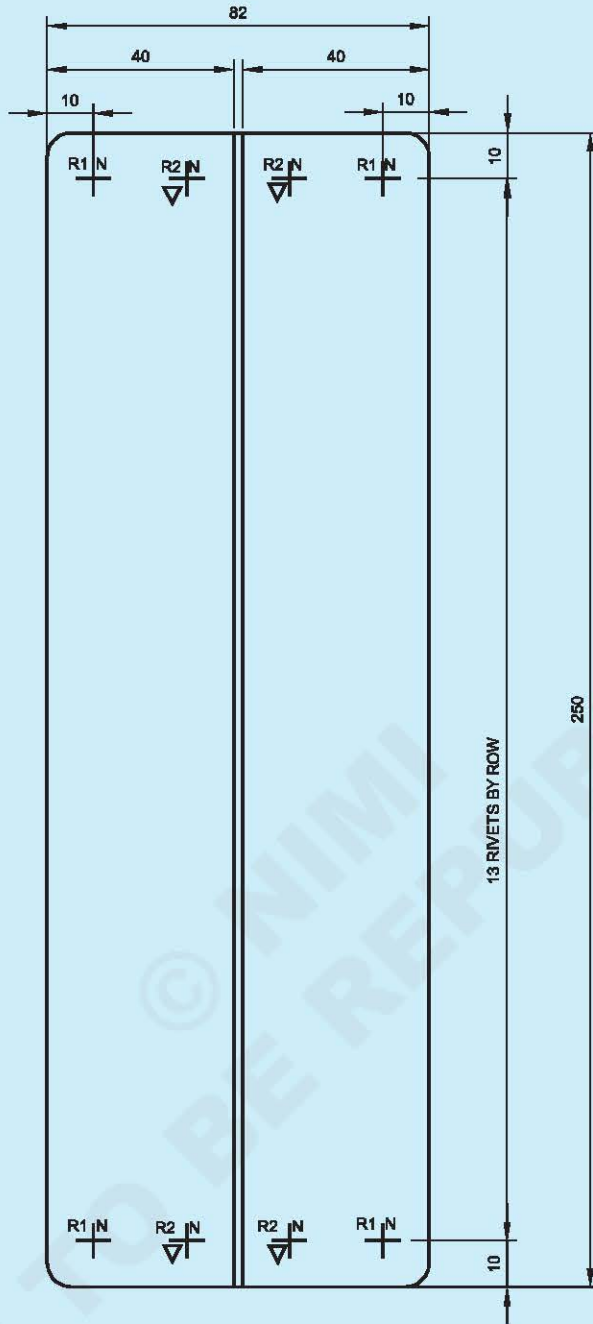

R1: UNIVERSAL HEAD SOLID RIVET, 2117 MATERIAL, Ø3.2 mm

R2: COUNTERSUNK HEAD SOLID RIVET, 2117 MATERIAL, Ø3.2 mm

1	-	-	-	-	-	2.1.31
NO.OFF	STOCK SIZE	SEMI-PRODUCT	MATERIAL	PROJECT NO.	PART NO.	EX. NO.
SCALE: NTS	RIVET GUN RIVETING ASSEMBLY AND RIVETING				DEVIATIONS	TIME: 20-HRS
					CODE NO : AFN2131E4	

PROCEDURE

- Check the parts.
- Mark and file item 1.
- Mark, file and drill item 2.
- Mark, file and drill item 3.
- On a flat surface (e.g. surface plate), join the items 01 and 02 together.
- Hold them in place with 2 clamps.
- Counter-drill 3 holes and clamp.
- Check the flushness.
- Drill other holes and clamp.
- On a flat surface (e.g. surface plate), join the items 01 and 03 together.
- Hold them in place with 2 clamps.
- Check the gap between item 2 and 3.
- Counter-drill 3 holes and clamp.
- Check the flushness.
- Drill other holes and clamp.
- Mark the workpieces by drawing marks with pencil.
- Dismantle the parts and deburr.
- Reassemble the workpieces with pins using the marks previously made.
- Countersink the corresponding holes.
- Rivet all unclamped holes beginning by the centre of the workpiece.
- Remove the pins and finish riveting.
- Check each rivet with a gauge.

REPORT SHEET

Report by drawing and measurement the defects on each rivet.
 Use red pen for non-allowable defects.
 Use blue or black pen for allowable defects.

Manufactured head side

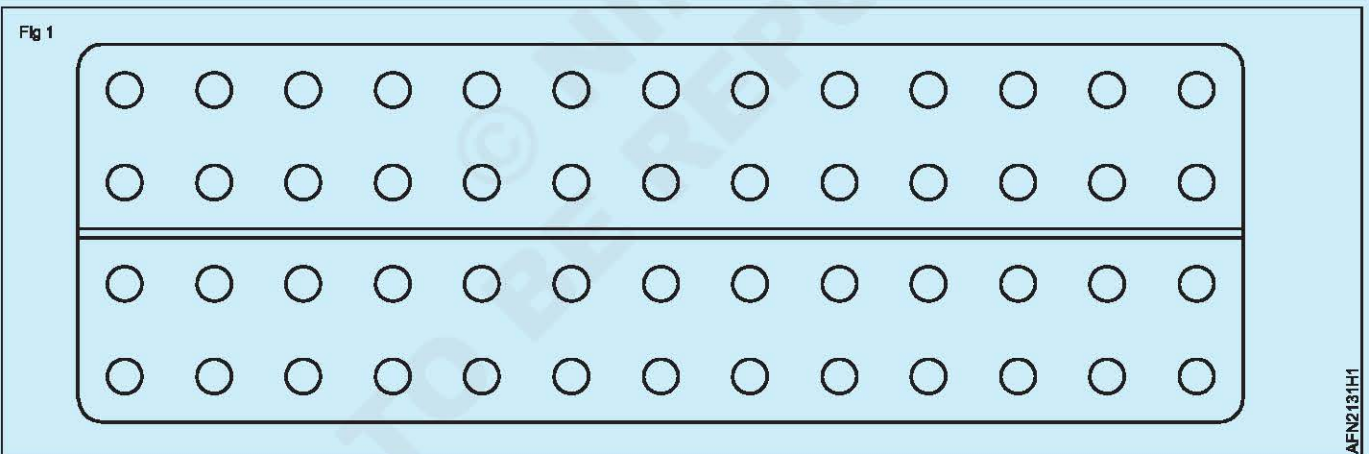

Shop head side

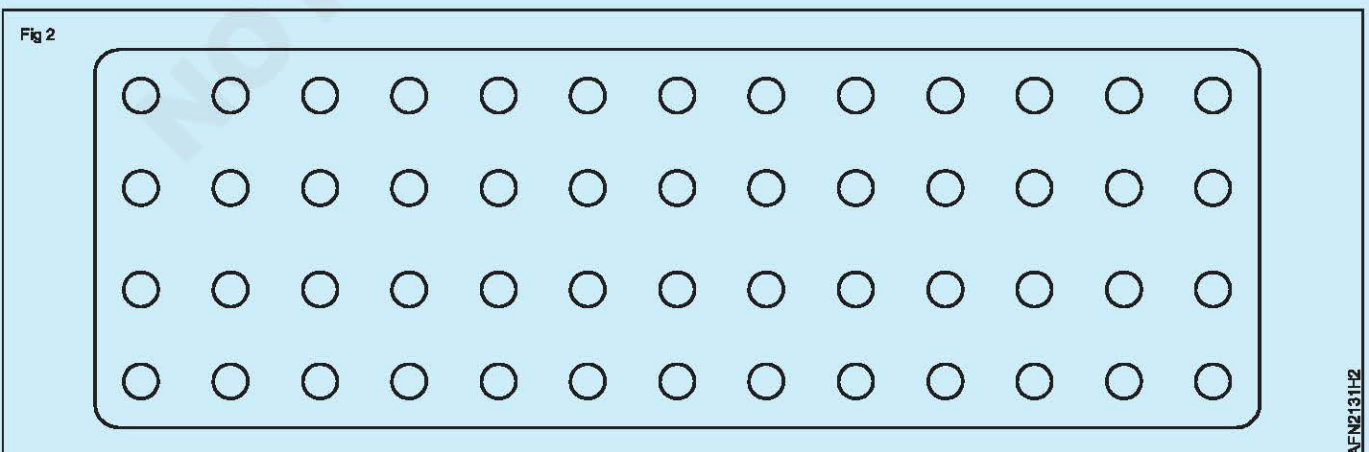

Riveting specimens

Objectives: At the end of this exercise you shall be able to

- manufacture riveting specimens
- make tensile test with riveting specimen.

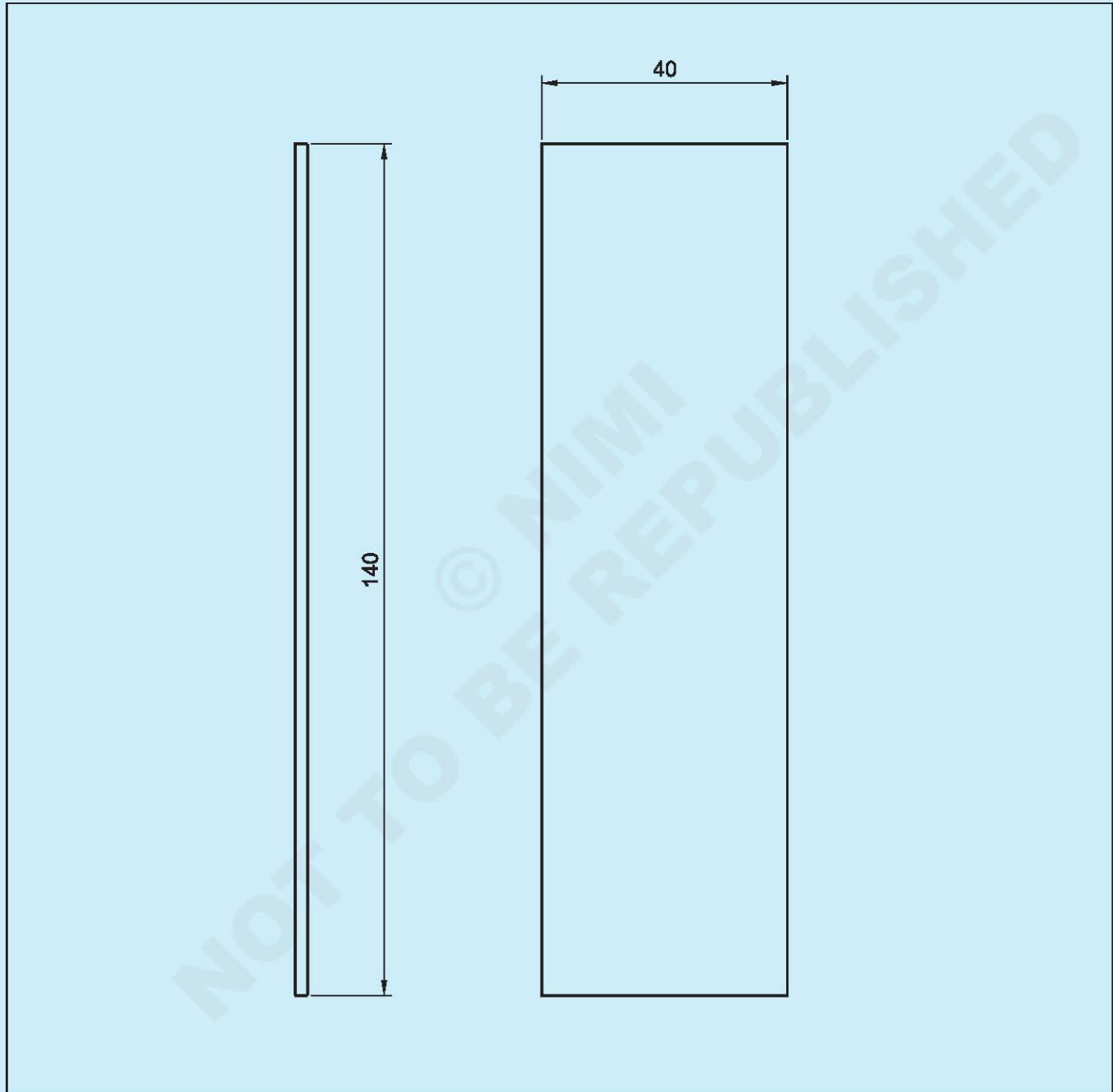

6	140 X 40 - 2MM	-	AW-2024	--	-	2.1.32
NO.OFF	STOCK SIZE	SEMI-PRODUCT	MATERIAL	PROJECT NO.	PART NO.	EX. NO.
SCALE: NTS	RIVETING SPECIMEN UNDRILLED PART				DEVIATIONS	TIME: 20HRS
					CODE NO : AFN2132E1	

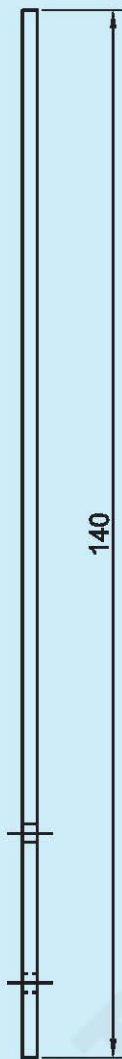

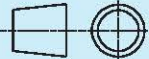
6	140 X 40 - 2MM	-	AW-2024	-	-	2.1.32
NO.OFF	STOCK SIZE	SEMI-PRODUCT	MATERIAL	PROJECT NO.	PART NO.	EX. NO.
SCALE: NTS	RIVETING SPECIMEN DRILLED PART				DEVIATIONS	TIME: 20HRS
					CODE NO : AFN2132E1	

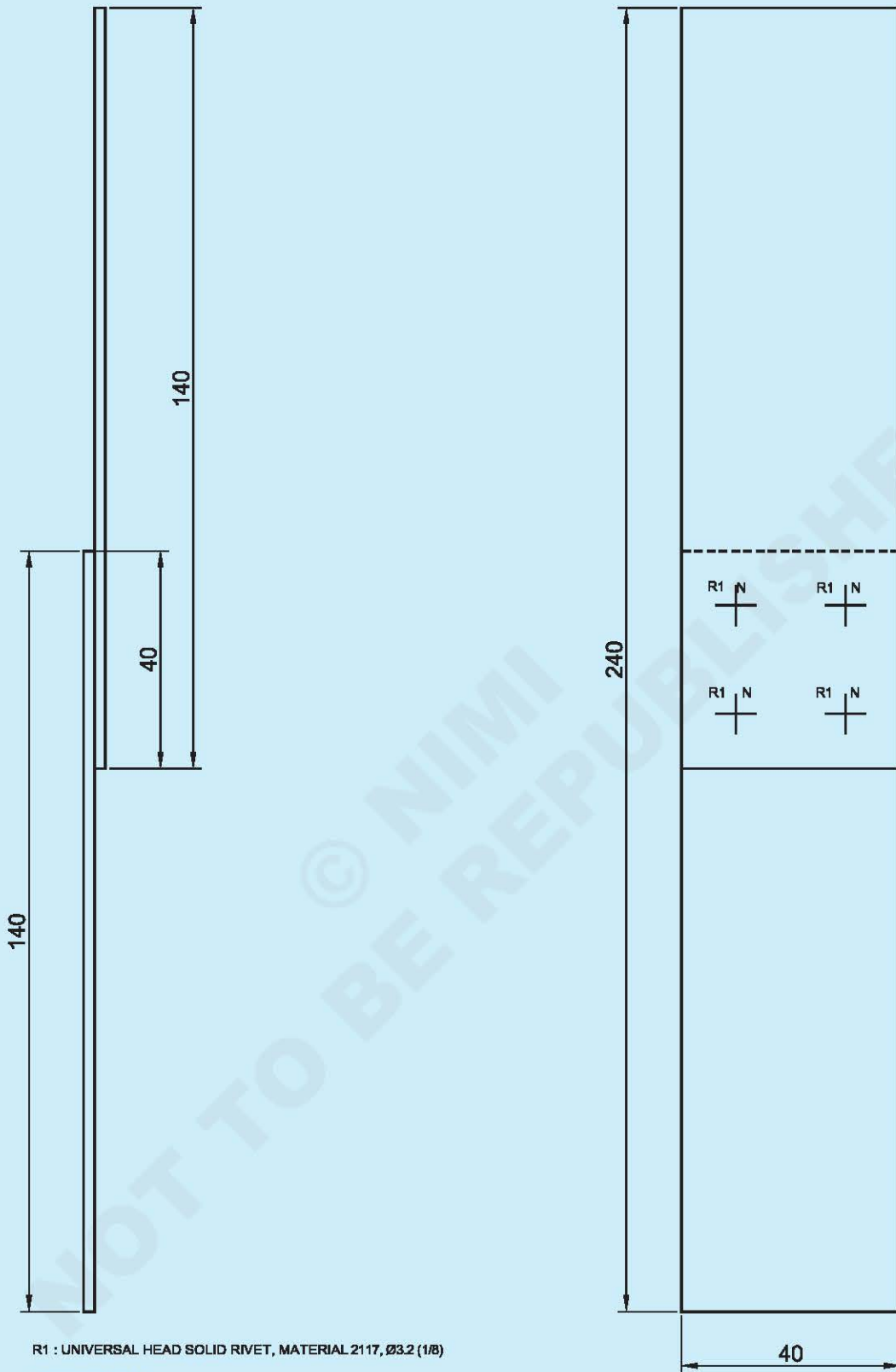

R1 : UNIVERSAL HEAD SOLID RIVET, MATERIAL 2117, Ø3.2 (1/8)
THICKNESS 2MM

3	-	--	--	-	--	2.1.32
NO.OFF	STOCK SIZE	SEMI-PRODUCT	MATERIAL	PROJECT NO.	PART NO.	EX. NO.
SCALE: NTS	RIVETING SPECIMEN UNIVERSAL HEAD RIVET - DIAMETER 4.0(5/32")				DEVIATIONS	TIME: 20HRS
					CODE NO : AFN2132E3	

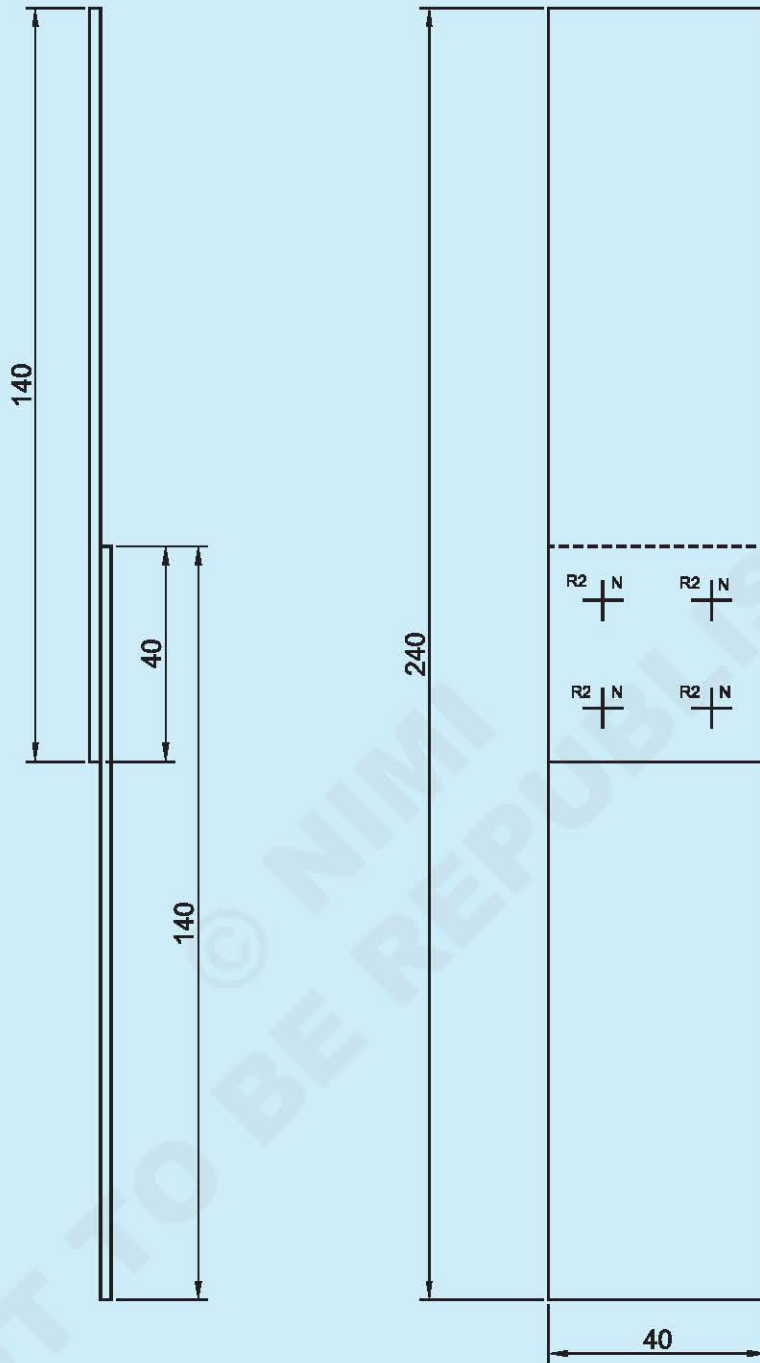

R2 : UNIVERSAL HEAD SOLID RIVET,
MATERIAL 2117, Ø4.0 mm (5/32")

THICKNESS: 2MM

3	-	--	--	-	--	2.1.32
NO.OFF	STOCK SIZE	SEMI-PRODUCT	MATERIAL	PROJECT NO.	PART NO.	EX. NO.
SCALE: NTS	RIVETING SPECIMEN UNIVERSAL HEAD RIVET - DIAMETER 4.0(5/32")				DEVIATIONS	TIME: 20HRS
					CODE NO : AFN2132E4	

PROCEDURE

TASK 1: Manufacturing parts

3.2 Undrilled parts

Quantity: 6

- 1 Check the parts
- 2 Mark and file.
- 3 Deburr.

Drilled parts

Quantity: 6

- 4 Check the parts
- 5 Mark and file.
- 6 Deburr.
- 7 Make and drill the four holes.
- 8 Deburr both sides.

TASK 2: Specimens assembly

3.2 Universal head rivet

Quantity: 3

- 1 On a flat surface (e.g. surface plate), join 1 drilled and 1 undrilled part together.
- 2 Hold them in place with 2 clamps.
- 3 Counter-drill 2 holes and clamp.
- 4 Check the flushness.
- 5 Drill other holes and clamp.
- 6 Check the flushness.
- 7 Drill other holes and clamp.
- 8 Counter-drill holes (diameter 3.3 mm) and clamp.
- 9 Mark the workpieces by drawing marks with pencil.
- 10 Dismantle the parts and deburr.
- 11 Reassemble the workpieces with pins using the marks previously made.
- 12 Countersink the corresponding holes.
- 13 Rivet all unclamped holes with a squeezer.
- 14 Remove the pins and finish riveting.
- 15 Check each rivet with a gauge.

Repeat 2 more times to manufacture other specimens.

4.0 UNIVERSAL HEAD RIVET

Quantity: 3

- On a flat surface (e.g. surface plate), join 1 drilled and 1 undrilled part together.
- Hold them in place with 2 clamps.
- Counter-drill 2 holes and clamp.
- Check the flushness.
- Drill other holes and clamp.
- Check the flushness.
- Drill other holes and clamp.
- Counter-drill holes (diameter 4.1 mm) and clamp.
- Mark the workpieces by drawing marks with pencil.
- Dismantle the parts and deburr.
- Reassemble the workpieces with pins using the marks previously made.
- Countersink the corresponding holes.
- Rivet all unclamped holes with a squeezer.
- Remove the pins and finish riveting.
- Check each rivet with a gauge.

Repeat 2 more times to manufacture other specimens.

TASK 3: Tensile test

- 1 Perform a tensile test on each specimen.
- 2 Analyse with the instructor the curves.
- 3 Compare the curve produced in 2.1.20 exercise.

Parts manufacturing #01 - Training beam sub - assembly

Objectives: At the end of this exercise you shall be able to

- manufacture parts
- make a sub-assembly.

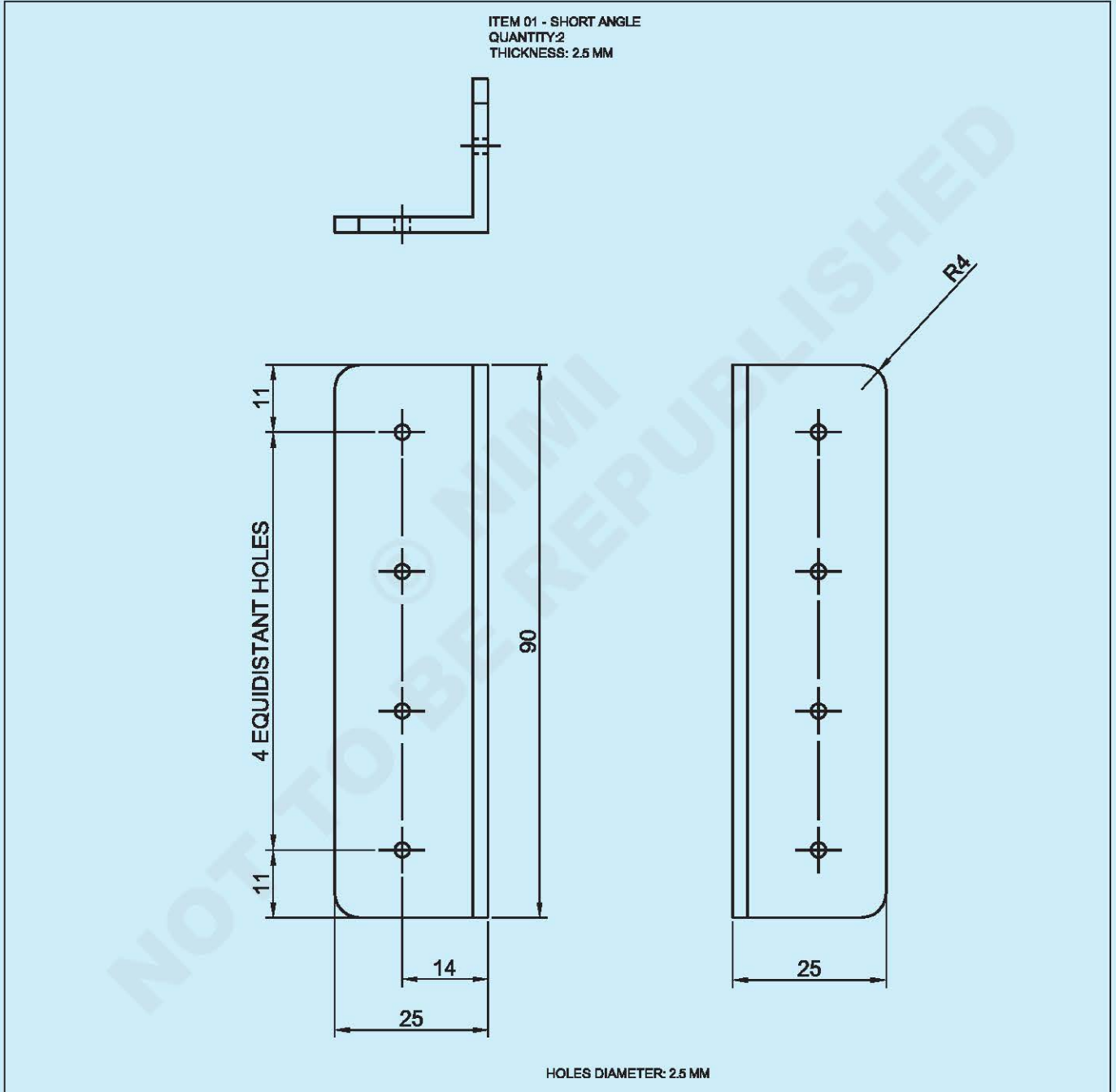

2	ANGLE 25X25X2.5	--	AW-2024	-	-	2.1.33
NO.OFF	STOCK SIZE	SEMI-PRODUCT	MATERIAL	PROJECT NO.	PART NO.	EX. NO.
SCALE: NTS	TRAINING BEAM ITEM 01				DEVIATIONS	TIME: 20HRS
					CODE NO : AFN2133E1	

ITEM 02 -WEB
 QUANTITY:1
 THICKNESS: 5 MM

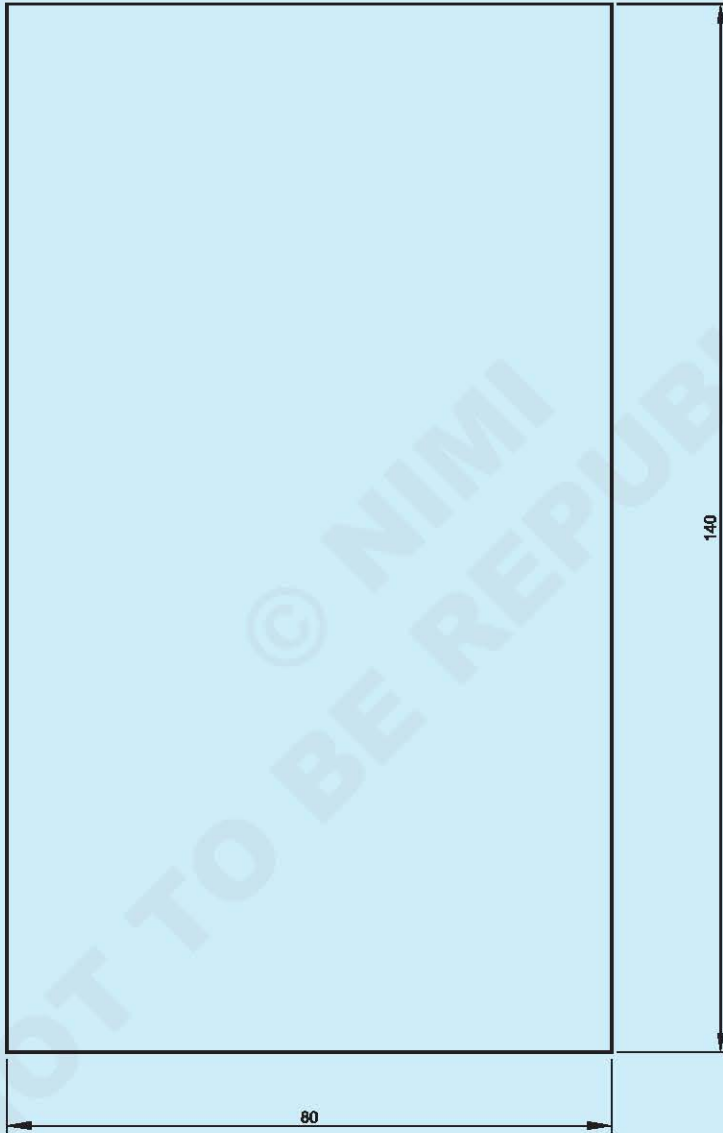

1	140X180 - 5MM	-	AW-2024	-	-	2.1.33
NO.OFF	STOCK SIZE	SEMI-PRODUCT	MATERIAL	PROJECT NO.	PART NO.	EX. NO.
SCALE: NTS	TRAINING BEAM ITEM 02				DEVIATIONS	TIME: 20HRS
					CODE NO : AFN2133E2	

ITEM 03 - SHORT SKIN
 QUANTITY:1
 THICKNESS: 2 MM

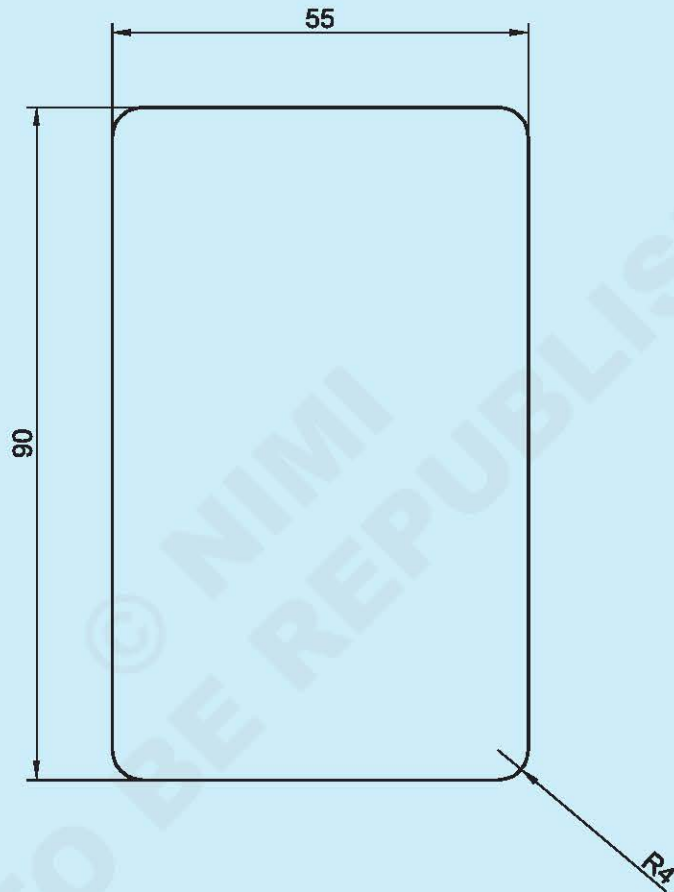

NOT TO BE REPUBLISHED

1	55X90 -2MM	-	AW-2024	--	-	2.1.33
NO.OFF	STOCK SIZE	SEMI-PRODUCT	MATERIAL	PROJECT NO.	PART NO.	EX. NO.
SCALE: NTS	TRAINING BEAM ITEM 03				DEVIATIONS	TIME: 20HRS
					CODE NO : AFN2133E3	

ITEM 04 - LONG ANGLE
 QUANTITY: 2
 THICKNESS: 2.5 MM

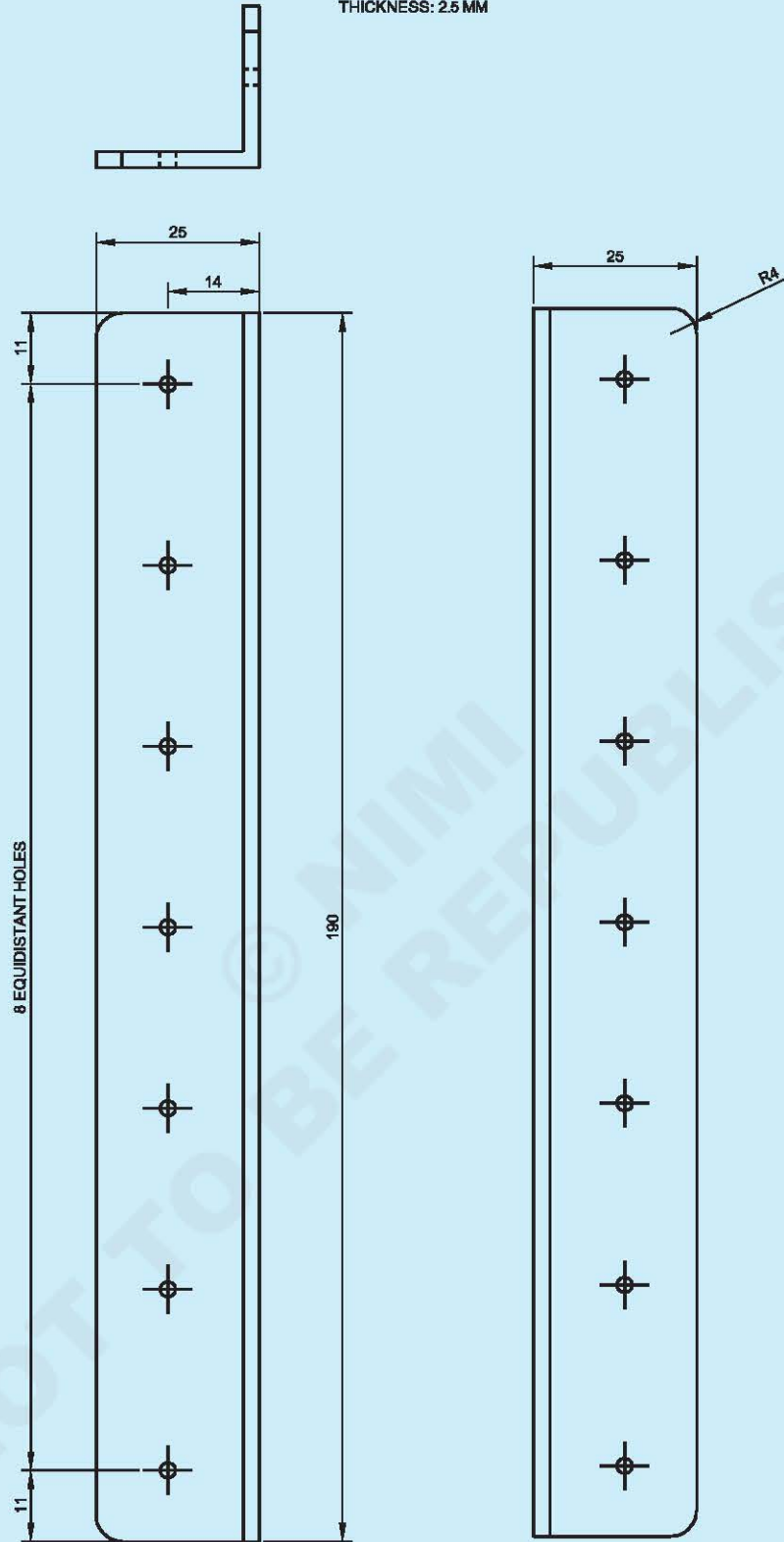

1	ANGLE 25X25X2.5	-	AW-2024	-	-	2.1.33
NO.OFF	STOCK SIZE	SEMI-PRODUCT	MATERIAL	PROJECT NO.	PART NO.	EX. NO.
SCALE: NTS	TRAINING BEAM ITEM 04				DEVIATIONS	TIME: 20HRS
					CODE NO : AFN2133E4	

ITEM 05 - LONG SKIN
 QUANTITY:1
 THICKNESS: 2 MM

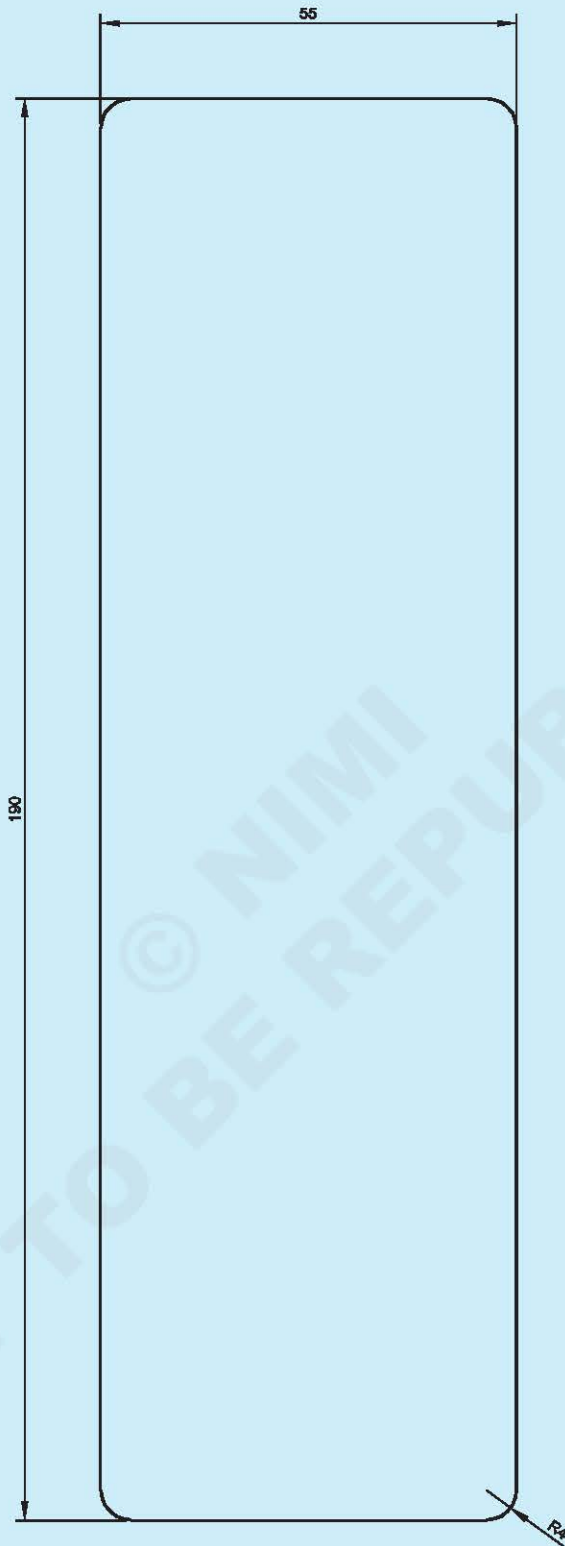

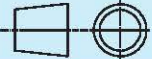
1	190X55 - 2MM	-	AW-2024	-	--	2.1.33
NO.OFF	STOCK SIZE	SEMI-PRODUCT	MATERIAL	PROJECT NO.	PART NO.	EX. NO.
SCALE: NTS	TRAINING BEAM ITEM 05				DEVIATIONS	TIME: 20HRS
					CODE NO : AFN2133E5	

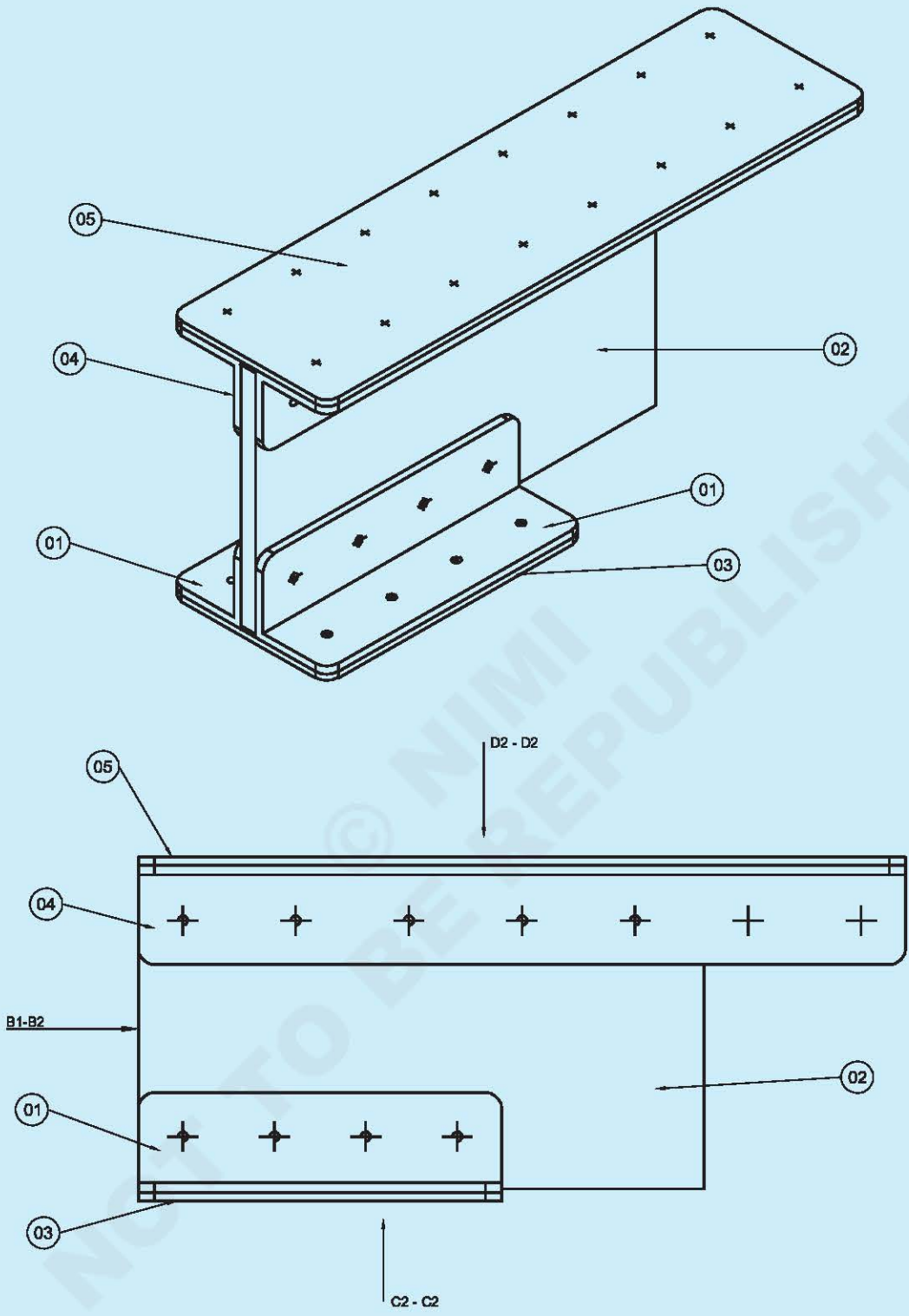

1	--	-	AW-2024	-	-	2.1.33
NO.OFF	STOCK SIZE	SEMI-PRODUCT	MATERIAL	PROJECT NO.	PART NO.	EX. NO.
SCALE: NTS	TRAINING BEAM SUB - ASSEMBLY - FOLIO 1				DEVIATIONS	TIME: 20HRS
					CODE NO : AFN2133E6	

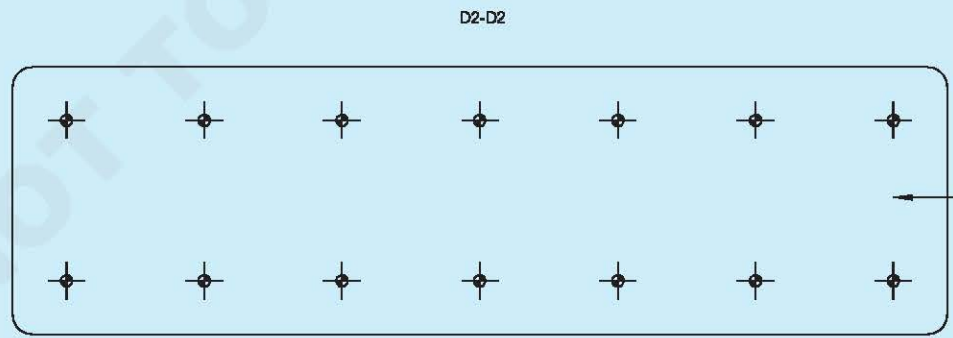
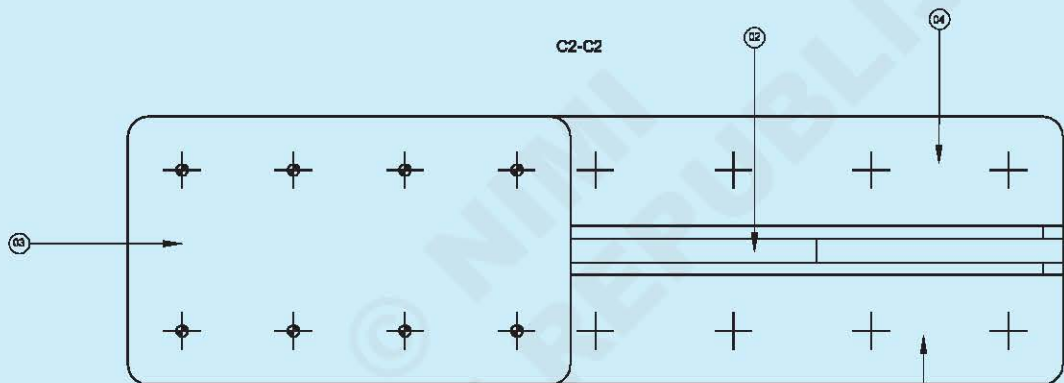
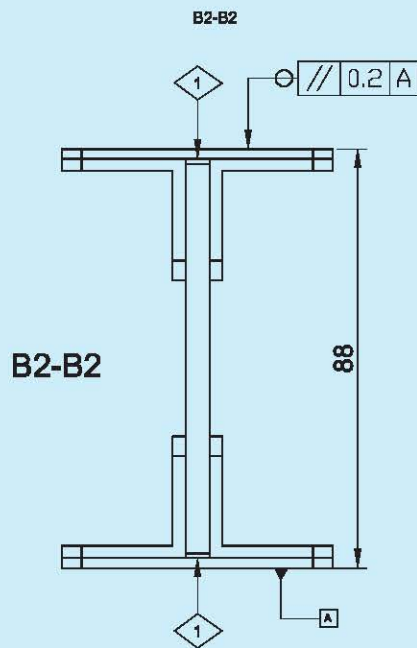

1	-	--	-	--	-	2.1.33
NO.OFF	STOCK SIZE	SEMI-PRODUCT	MATERIAL	PROJECT NO.	PART NO.	EX. NO.
SCALE: NTS	TRAINING BEAM SUB - ASSEMBLY - FOLIO 2				DEVIATIONS	TIME: 20HRS
					CODE NO : AFN2133E7	

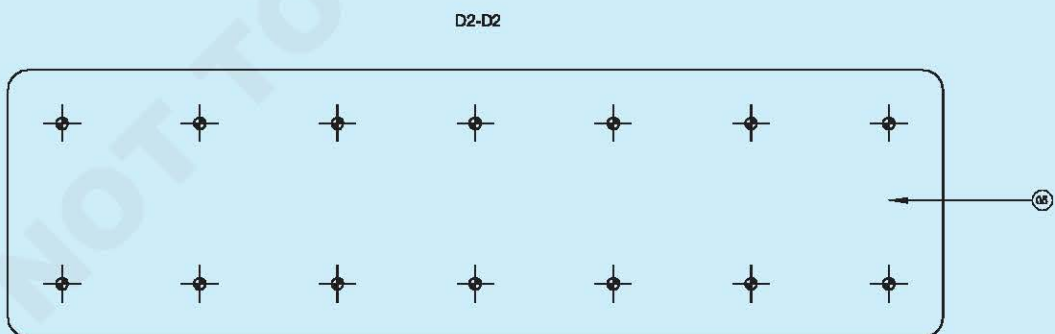
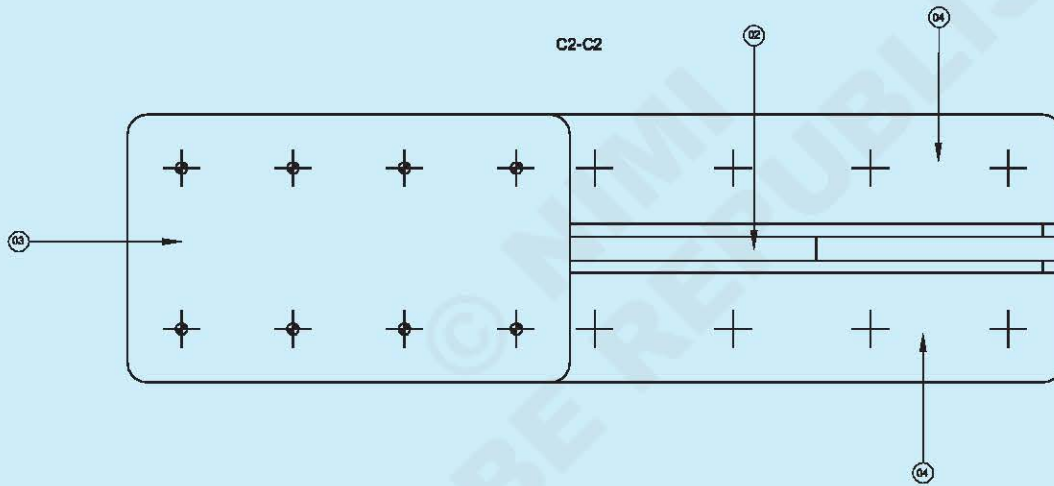
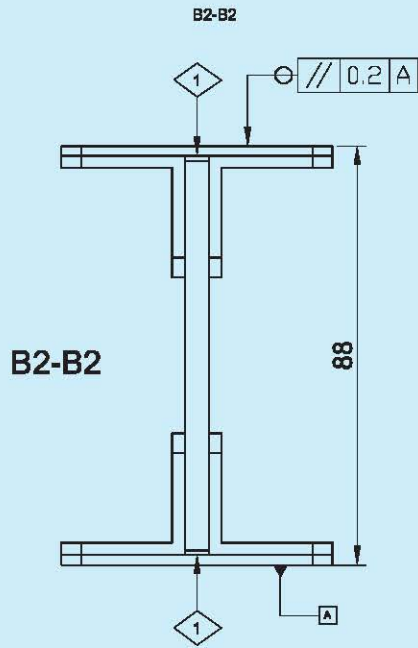

1	-	-	-	-	-	2.1.33
NO.OFF	STOCK SIZE	SEMI-PRODUCT	MATERIAL	PROJECT NO.	PART NO.	EX. NO.
SCALE: NTS	TRAINING BEAM SUB - ASSEMBLY - FOLIO 2				DEVIATIONS	TIME: 20HRS
					CODE NO : AFN2133E7	

PROCEDURE

TASK 1: Manufacturing parts

Item 01

Quantity: 2

- Check the parts.
- Mark and file.
- Deburr.
- Make and drill the four holes.
- Deburr both sides.

ITEM 02

Quantity: 1

- Check the parts.
- Mark and file.
- Deburr.

ITEM 03

Quantity: 1

- Check the parts.

- Mark and file.
- Deburr.

ITEM 04

Quantity: 2

- Check the parts.
- Mark and file.
- Deburr.
- Make and drill the four holes.
- Deburr both sides.

ITEM 05

Quantity: 1

- Check the parts.
- Mark and file.
- Deburr.

REPORT SHEET

ITEM 01	CORRECT	<input type="checkbox"/> YES	<input type="checkbox"/> NO	REMARKS:
ITEM 01	CORRECT	<input type="checkbox"/> YES	<input type="checkbox"/> NO	REMARKS:
ITEM 02	CORRECT	<input type="checkbox"/> YES	<input type="checkbox"/> NO	REMARKS:
ITEM 03	CORRECT	<input type="checkbox"/> YES	<input type="checkbox"/> NO	REMARKS:
ITEM 04	CORRECT	<input type="checkbox"/> YES	<input type="checkbox"/> NO	REMARKS:
ITEM 04	CORRECT	<input type="checkbox"/> YES	<input type="checkbox"/> NO	REMARKS:
ITEM 05	CORRECT	<input type="checkbox"/> YES	<input type="checkbox"/> NO	REMARKS:

OBSERVATIONS:

TASK 2: Assembly

- On a flat surface (e.g. surface plate). Join the item 02 with one item 04 together
- Hold them in place with 2 clamp
- Counter-drill 2 holes and clamp.
- Check the flushness and the gap.
- Drill other holes and clamp.
- Dismantle the parts and deburr.
- On a flat surface (e.g. surface plate), assemble item 02 with items 04 using pins. (see figure 2).
- Assemble item 02 with items 04 using pins.
- Check geometrical requests.
- Put in position the item 05 (see figure 3).
- Check the flushness with the other parts and hold with clamps.

Use a shim to have the requested gap (see figure 1).

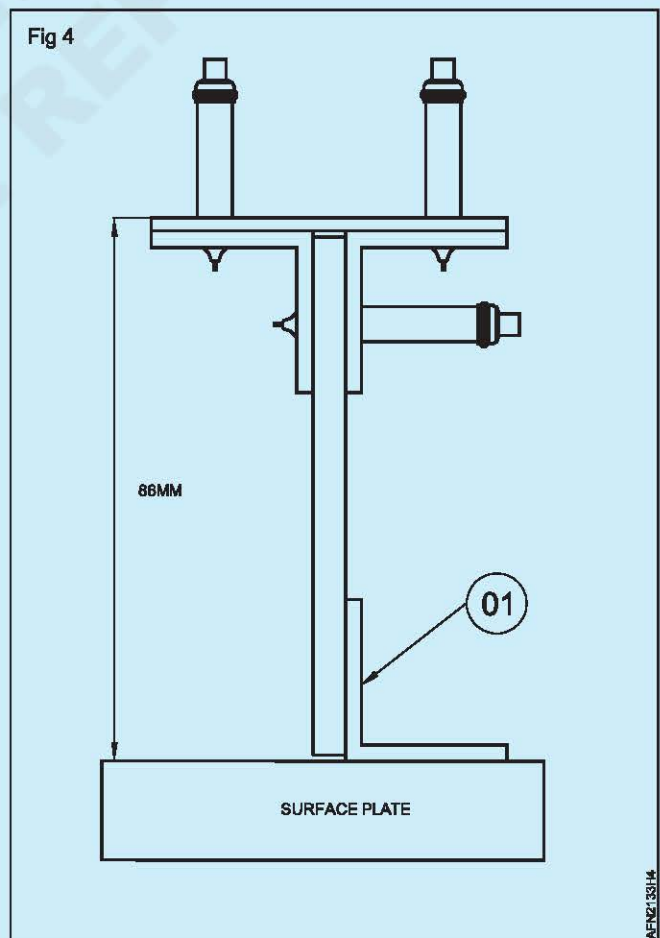
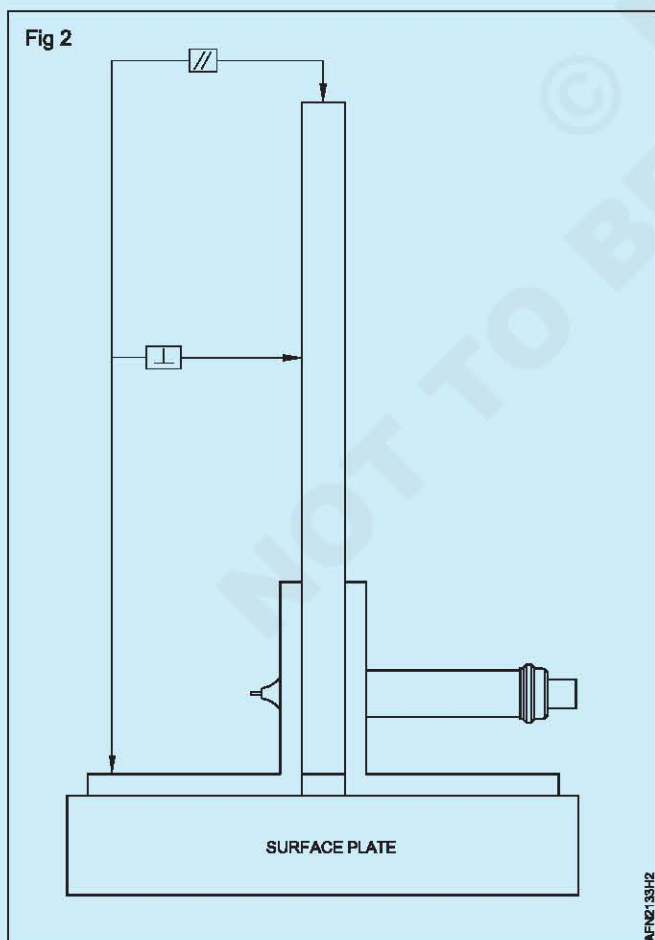
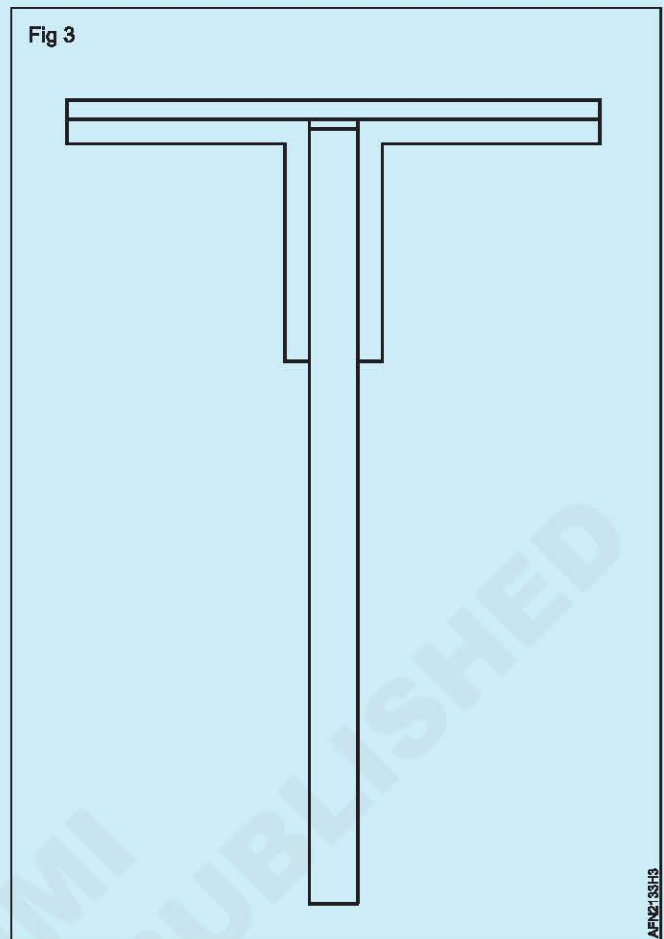
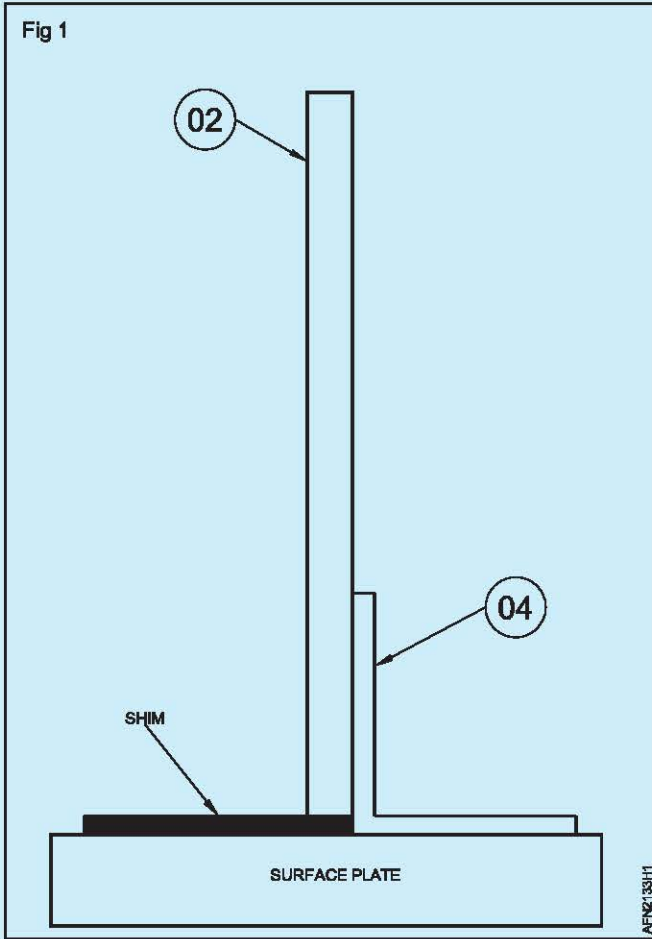

- Counter-drill 2 holes and clamp.
- Check the flushness and the gap.
- Drill other holes and clamp.
- Dismantle the parts and deburr.
- Reassemble the parts using pins.
- On a flat surface (e.g. surface plate), join the item 02 (with the assembly made above) with one item 01 together. (see figure 4)

**Ensure the height requested in the drawing.
Use shim to facilitate the positioning.**

- Hold them in place with 2 clamps.
- Counter-drill 2 holes and clamp.
- Check the flushness and the gap.
- Drill other holes and clamp.
- Put in position the item 03.
- Check the flushness with the other parts and hold with clamps.

- Counter-drill 2 holes and clamp.
- Check the flushness and the gap.
- Drill other holes and clamp.
- Dismantle the parts and deburr.
- Reassemble the parts using pins.
- Counter-drill holes at final diameter and clamp.
- Mark the workpieces by drawing marks with pencil.
- Dismantle the parts and deburr.
- Reassemble the workpieces with pins using the marks previously made.
- Countersink the corresponding holes.
- Rivet all unclamped holes.
- Remove the pins and finish riveting.
- Check each rivet with a gauge.

REPORT SHEET

Report by drawing the scratches, defects on rivets, etc. with a simple identification of the defect.

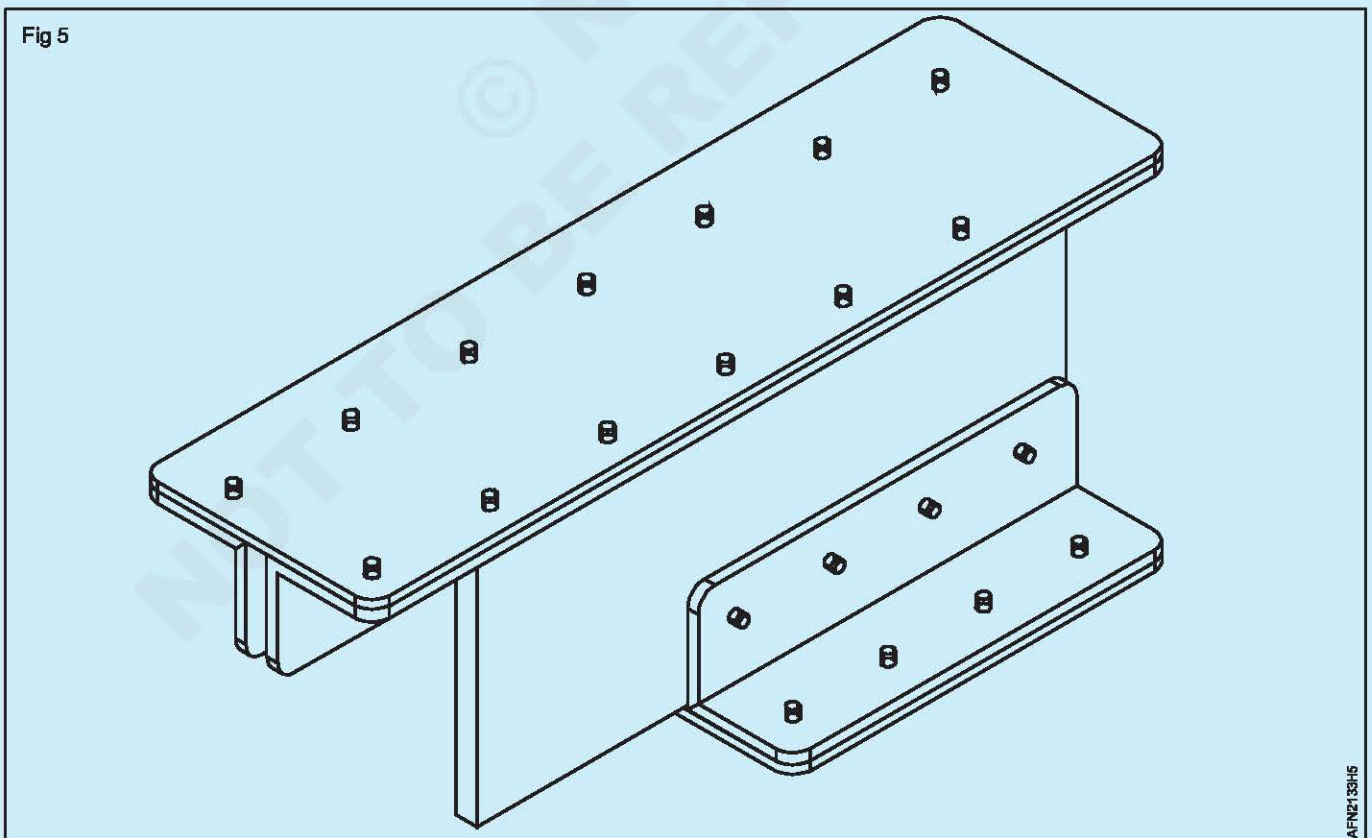
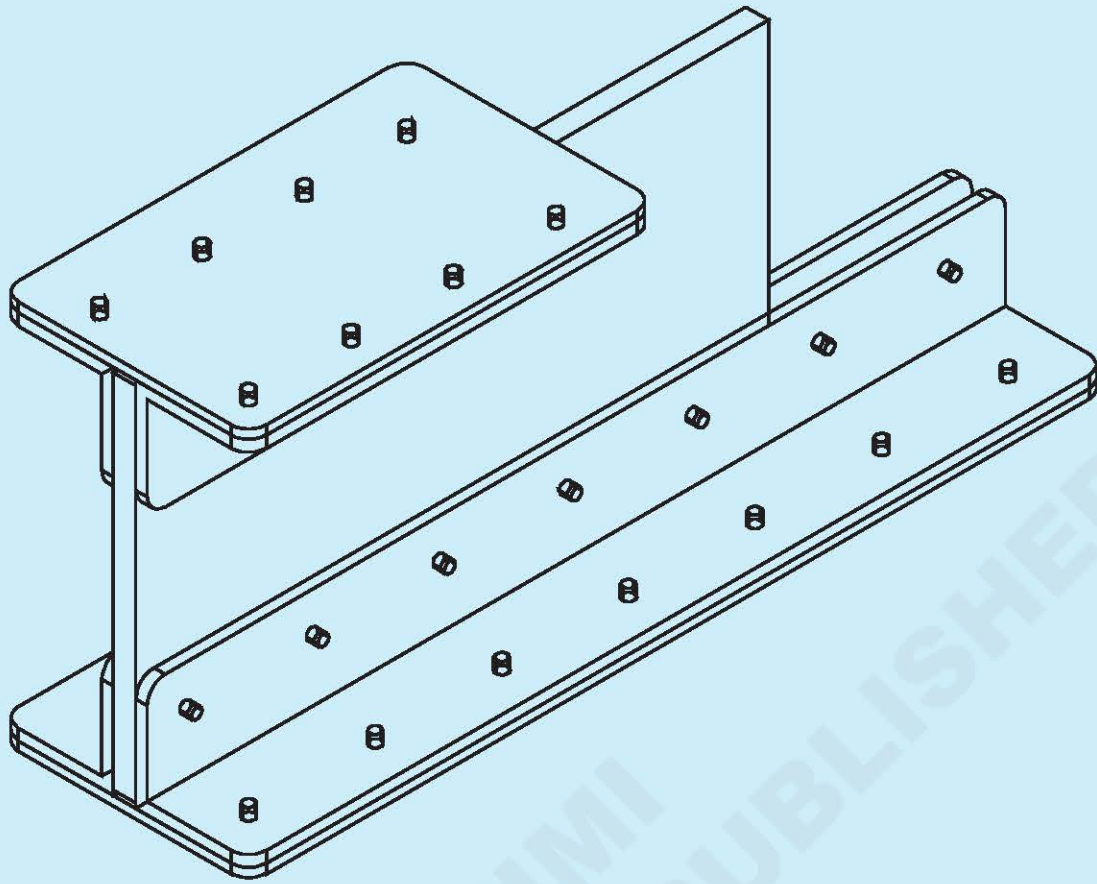
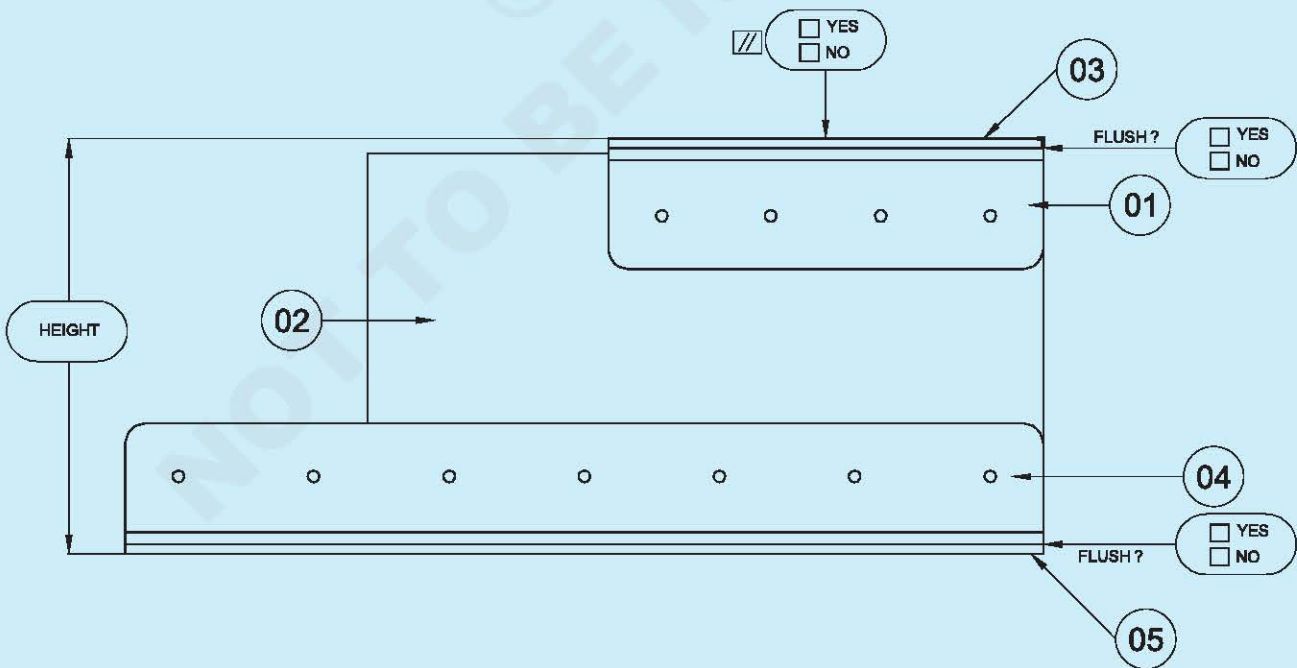

Fig 6



AFN2133H6

Fig 7



AFN2133H7

Fig 8

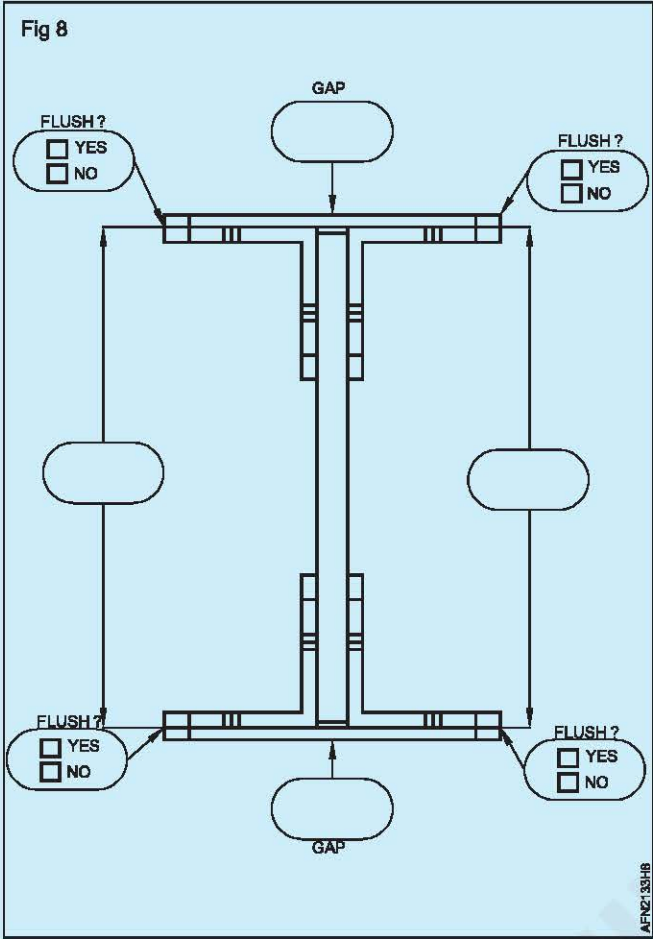

AFNC133HB

Parts manufacturing #02 - Flat panel

Objectives: At the end of this exercise you shall be able to

- manufacture parts
- make a sub-assembly.

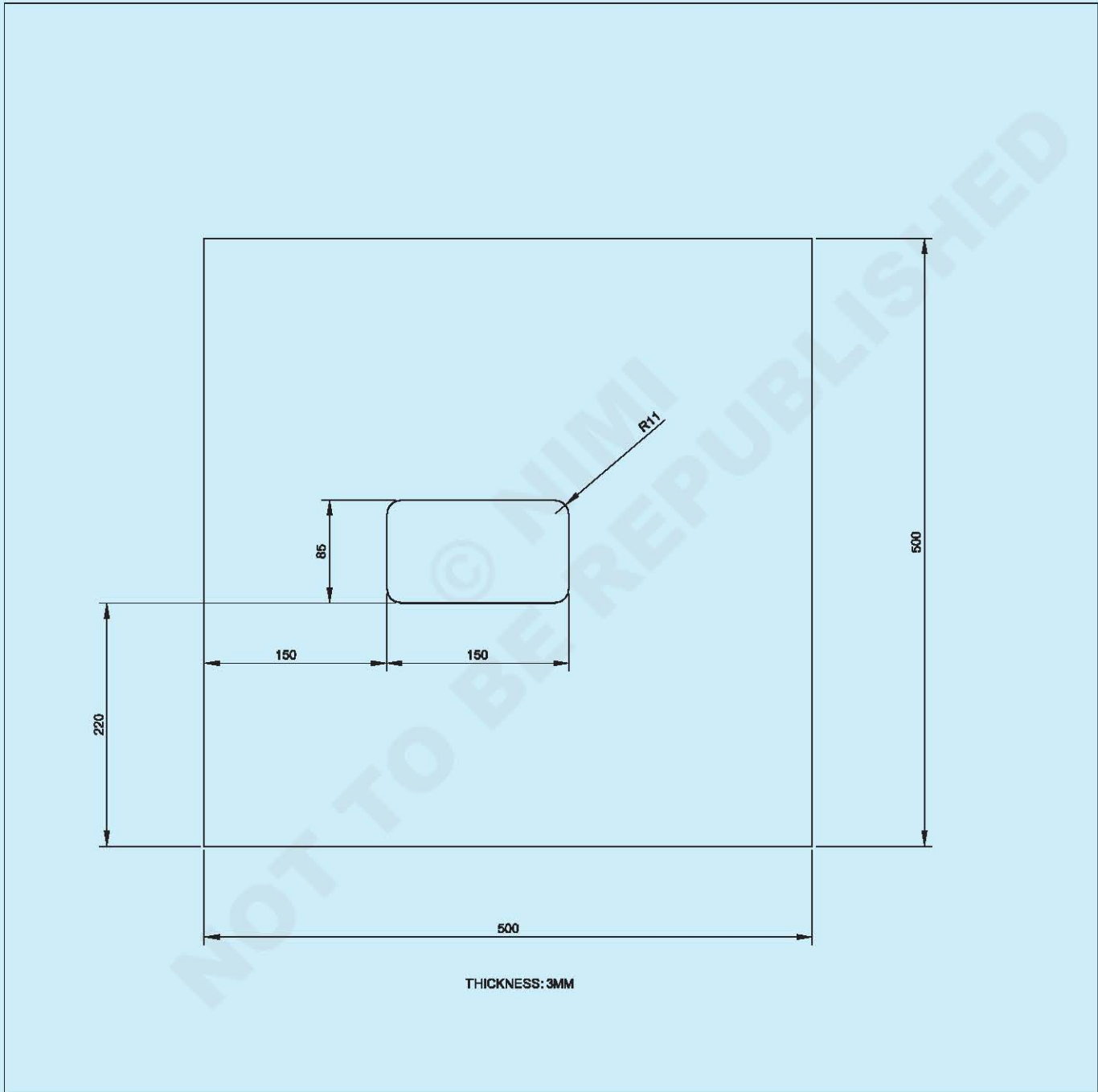

1	500X500 - 3MM	-	AW-2024	-	-	2.1.34
NO.OFF	STOCK SIZE	SEMI-PRODUCT	MATERIAL	PROJECT NO.	PART NO.	EX. NO.
SCALE: NTS	FLAT PLATE ITEM 01 - SKIN				DEVIATIONS	TIME: 20HRS
					CODE NO : AFN2134E1	

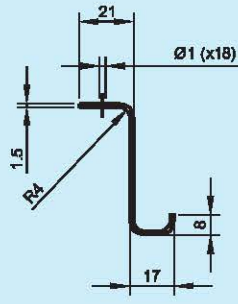
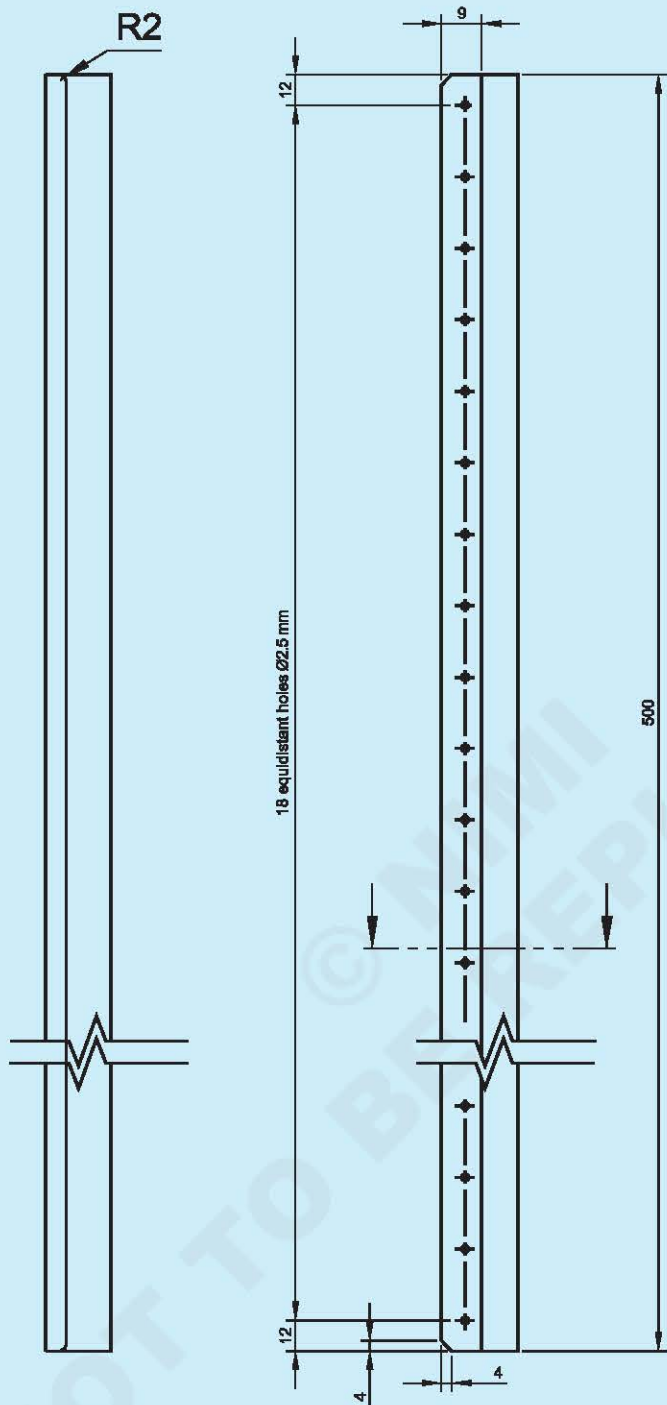

4	500X50 - 1.5MM	-	AW-2024	-	--	2.1.34
NO.OFF	STOCK SIZE	SEMI-PRODUCT	MATERIAL	PROJECT NO.	PART NO.	EX. NO.
SCALE: NTS	FLAT PLATE ITEM 02 - STRINGER				DEVIATIONS	TIME: 20HRS
					CODE NO : AFN2134E1	

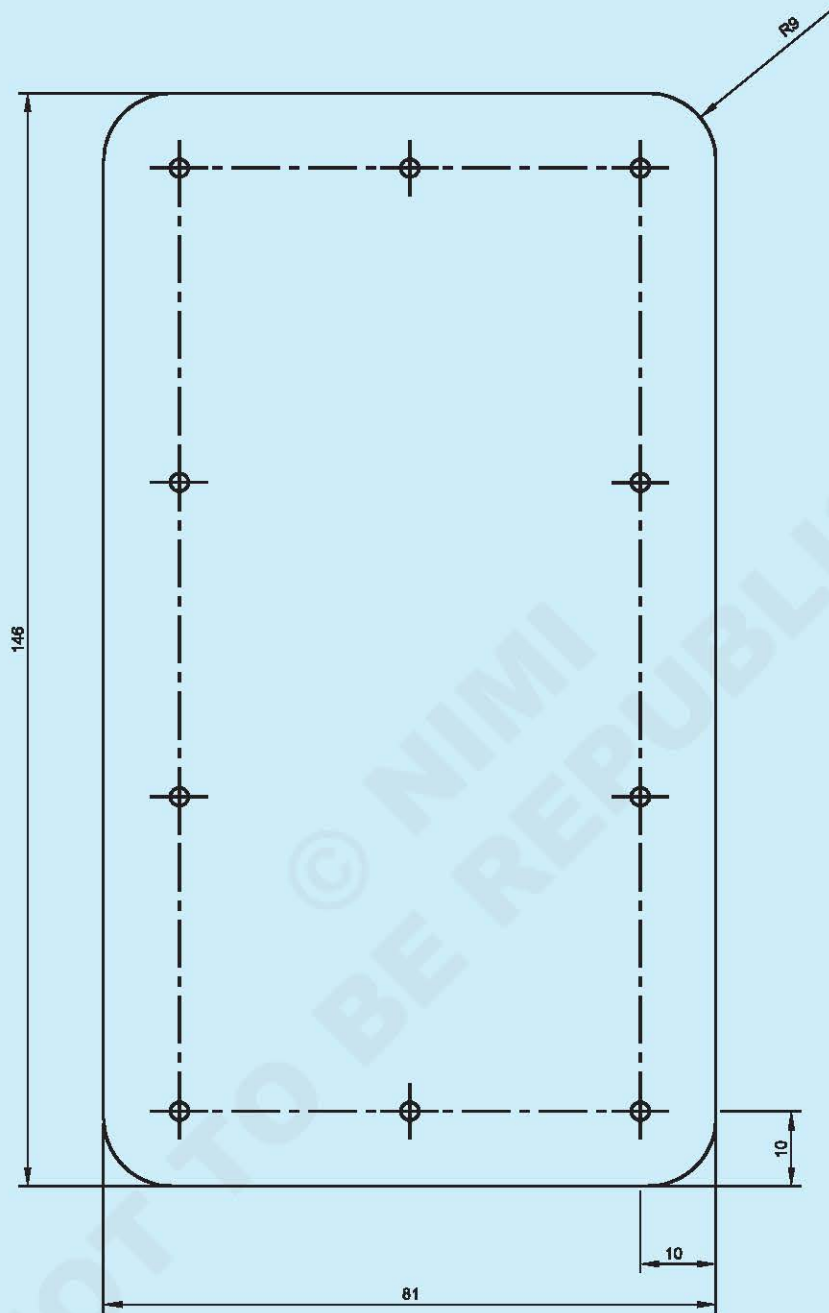

HOLES DIAMETER: 2.5MM

4	150X84 - 2MM	-	AW-2024	-	--	2.1.34
NO.OFF	STOCK SIZE	SEMI-PRODUCT	MATERIAL	PROJECT NO.	PART NO.	EX. NO.
SCALE: NTS		FLAT PANEL ITEM 03 - DOOR			DEVIATIONS	TIME: 20HRS
					CODE NO : AFN2134E3	

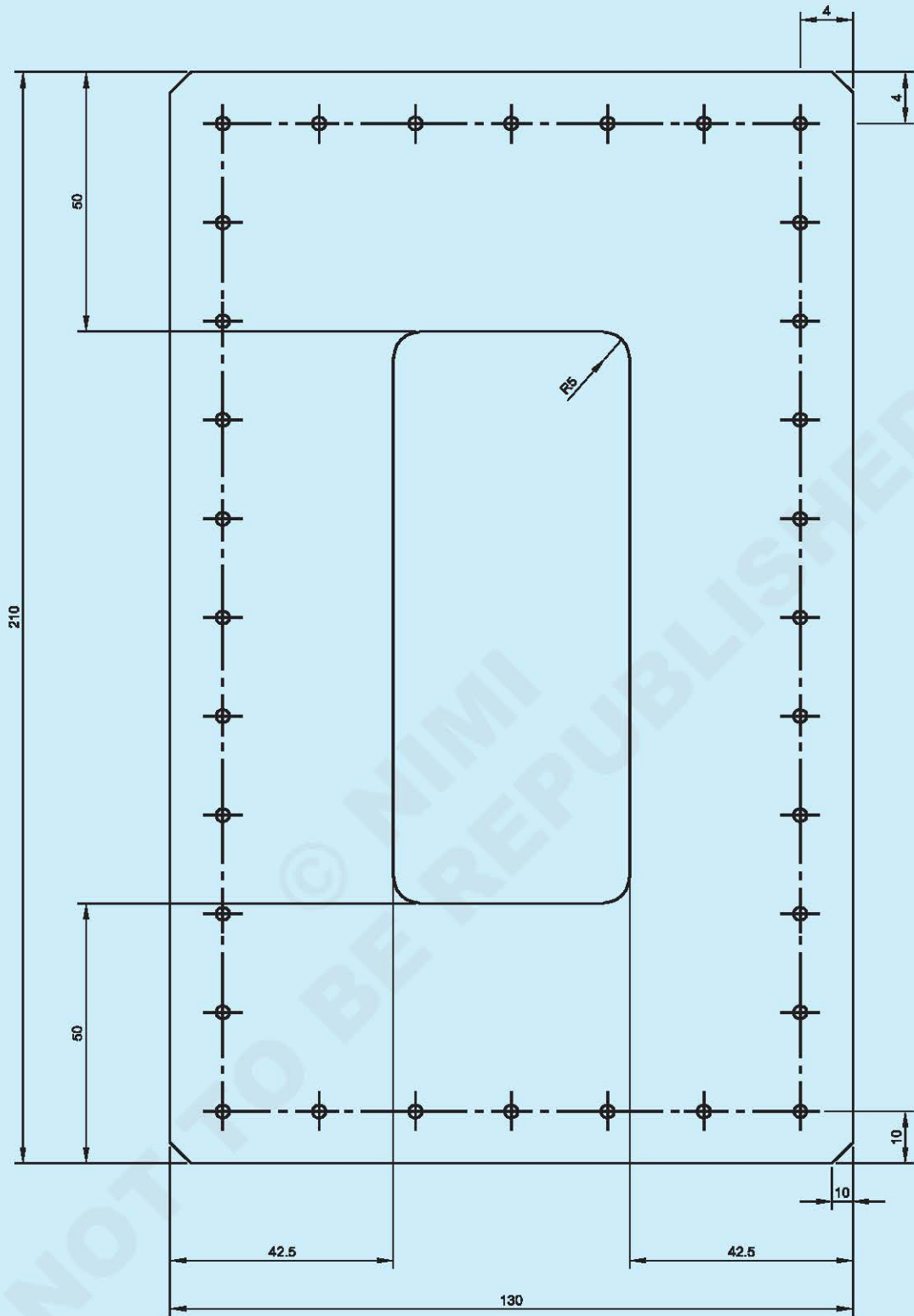

THICKNESS 1.5 MM
HOLES DIAMETER 2.5 MM

4	210X 130 - 1.5MM	-	AW-2024	--	-	2.1.34
NO.OFF	STOCK SIZE	SEMI-PRODUCT	MATERIAL	PROJECT NO.	PART NO.	EX. NO.
SCALE: NTS	FLAT PANEL ITEM 04 - DOUBLER				DEVIATIONS	TIME: 20HRS
					CODE NO : AFN2134E4	

PROCEDURE

TASK 1: Manufacturing parts

ITEM 01

Quantity: 1

- Check the parts.
- Mark and file external dimensions.
- Deburr.
- Trace the cut-out in the panel.
- Mark the centres of the 22 mm diameter holes.
- Drill the four holes.
- Deburr both sides.
- Cut with a hacksaw along the line.
- File and deburr edges.

ITEM 02

Quantity: 4

- Check the parts.
- Calculate the developed length.
- Adjust the external dimensions.
- Draw the bending lines.
- Bend the piece (the folding order is left to your own. Discuss this with the instructor.)
- Trace the hole lines.
- Drill the workpiece.
- Deburr.

ITEM 03

Quantity: 1

- Check the parts.
- Mark and file the external dimensions and the radii.
- Trace the hole lines.
- Drill the workpiece.
- Deburr.

ITEM 04

Quantity: 1

- Check the parts.
- Mark and file the external dimensions and the chamfers.
- Trace the cut-out.
- Mark the centres of the 10 mm diameter holes.
- Drill the four holes.
- Deburr both sides.
- Cut along the line.
- File and deburr edges.
- Trace the hole lines.
- Drill the workpiece.
- Deburr.

REPORT SHEET

ITEM 01	CORRECT	<input type="checkbox"/> YES <input type="checkbox"/> NO	REMARKS:
ITEM 02a	CORRECT	<input type="checkbox"/> YES <input type="checkbox"/> NO	REMARKS:
ITEM 02b	CORRECT	<input type="checkbox"/> YES <input type="checkbox"/> NO	REMARKS:
ITEM 02c	CORRECT	<input type="checkbox"/> YES <input type="checkbox"/> NO	REMARKS:
ITEM 02d	CORRECT	<input type="checkbox"/> YES <input type="checkbox"/> NO	REMARKS:
ITEM 03	CORRECT	<input type="checkbox"/> YES <input type="checkbox"/> NO	REMARKS:
ITEM 04	CORRECT	<input type="checkbox"/> YES <input type="checkbox"/> NO	REMARKS:
OBSERVATIONS:			

Parts assembly #01 - Training beam - Junction

Objectives: At the end of this exercise you shall be able to

- assemble parts
- assemble sub-assemblies.

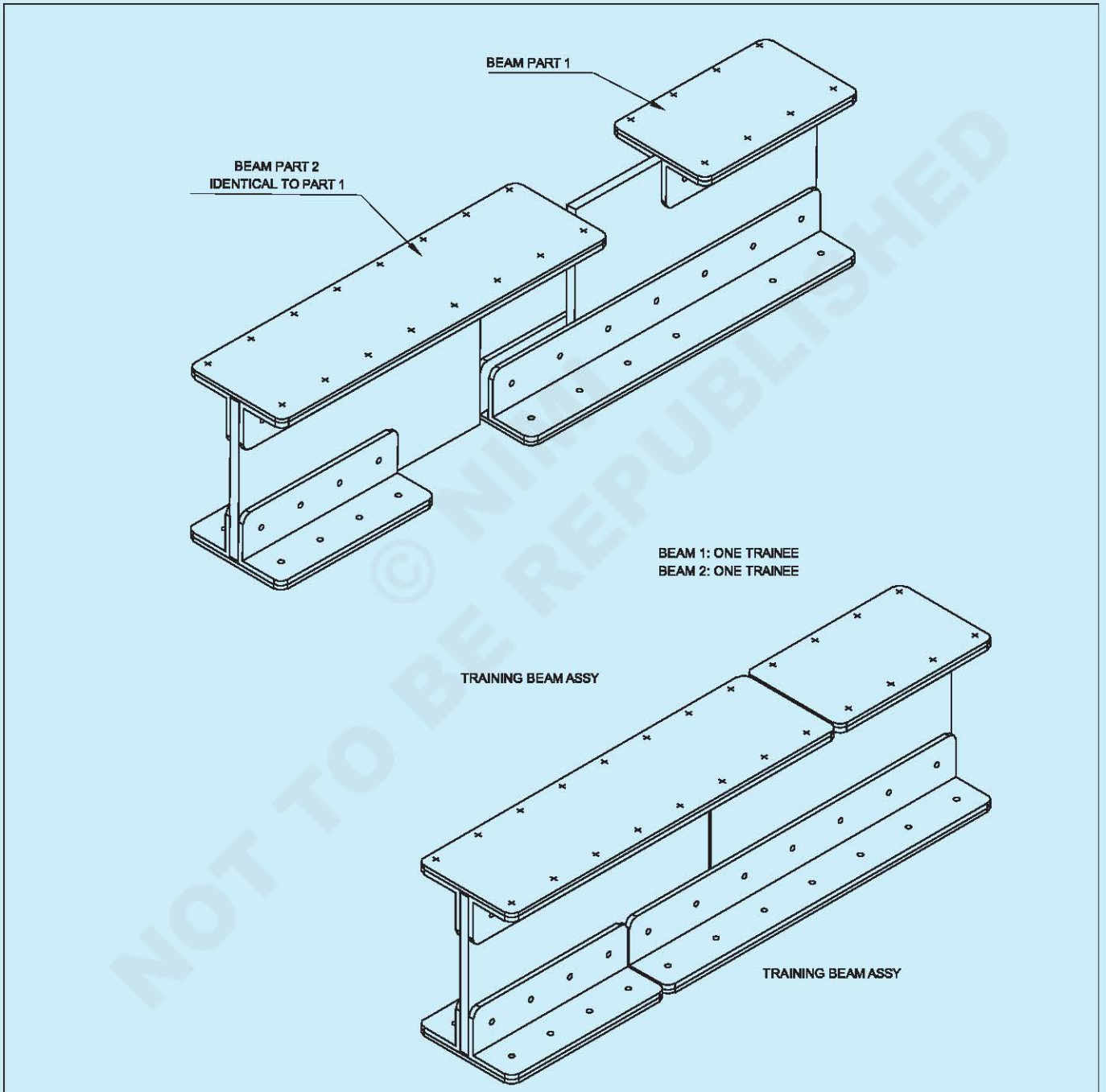

-	--	2.1.33	-	-	--	2.1.35
NO.OFF	STOCK SIZE	SEMI-PRODUCT	MATERIAL	PROJECT NO.	PART NO.	EX. NO.
SCALE: NTS	TRAINING BEAM JUNCTION - FOLIO 1				DEVIATIONS	TIME: 5HRS
					CODE NO : AFN2135E1	

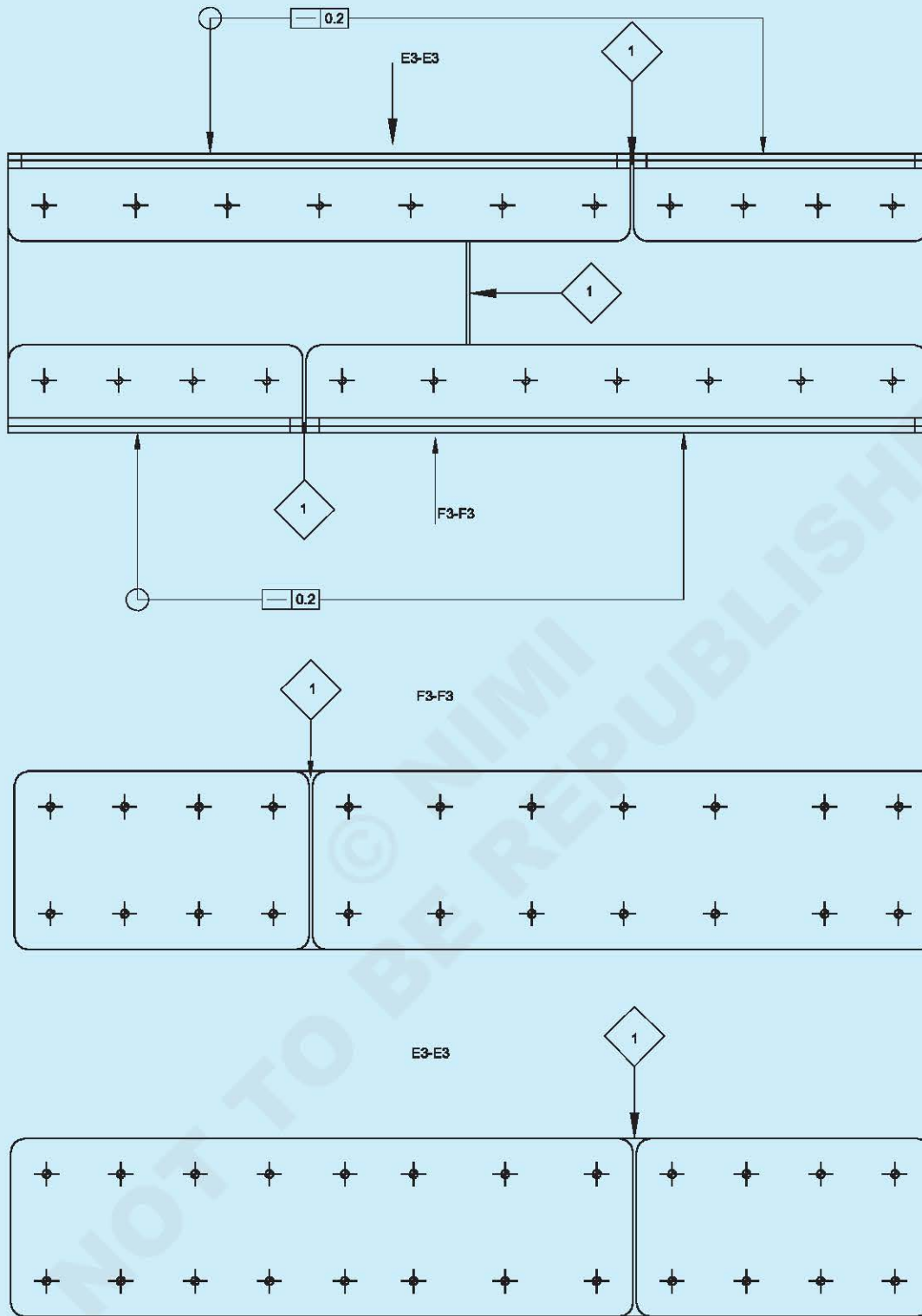

-	-	→ 2.1.33	--	--	-	2.1.35
NO.OFF	STOCK SIZE	SEMI-PRODUCT	MATERIAL	PROJECT NO.	PART NO.	EX. NO.
SCALE: NTS	TRAINING BEAM JUNCTION - FOLIO 2				DEVIATIONS	TIME: 6HRS
					CODE NO : AFN2135E2	

Keys

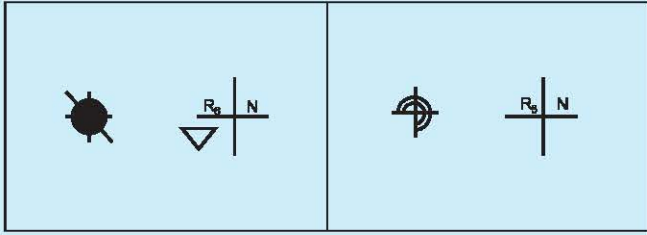

R6: Countersunk head rivet - 2117 material - 3.2 (1/8") diameter

R8: Universal head rivet - 2117 material - 4.0 (5/32") diameter

1 GAP - mini 1mm

REPORT SHEET

Report by drawing the scratches, defects on rivets, etc. with a simple identification of the defect.

Fig 1

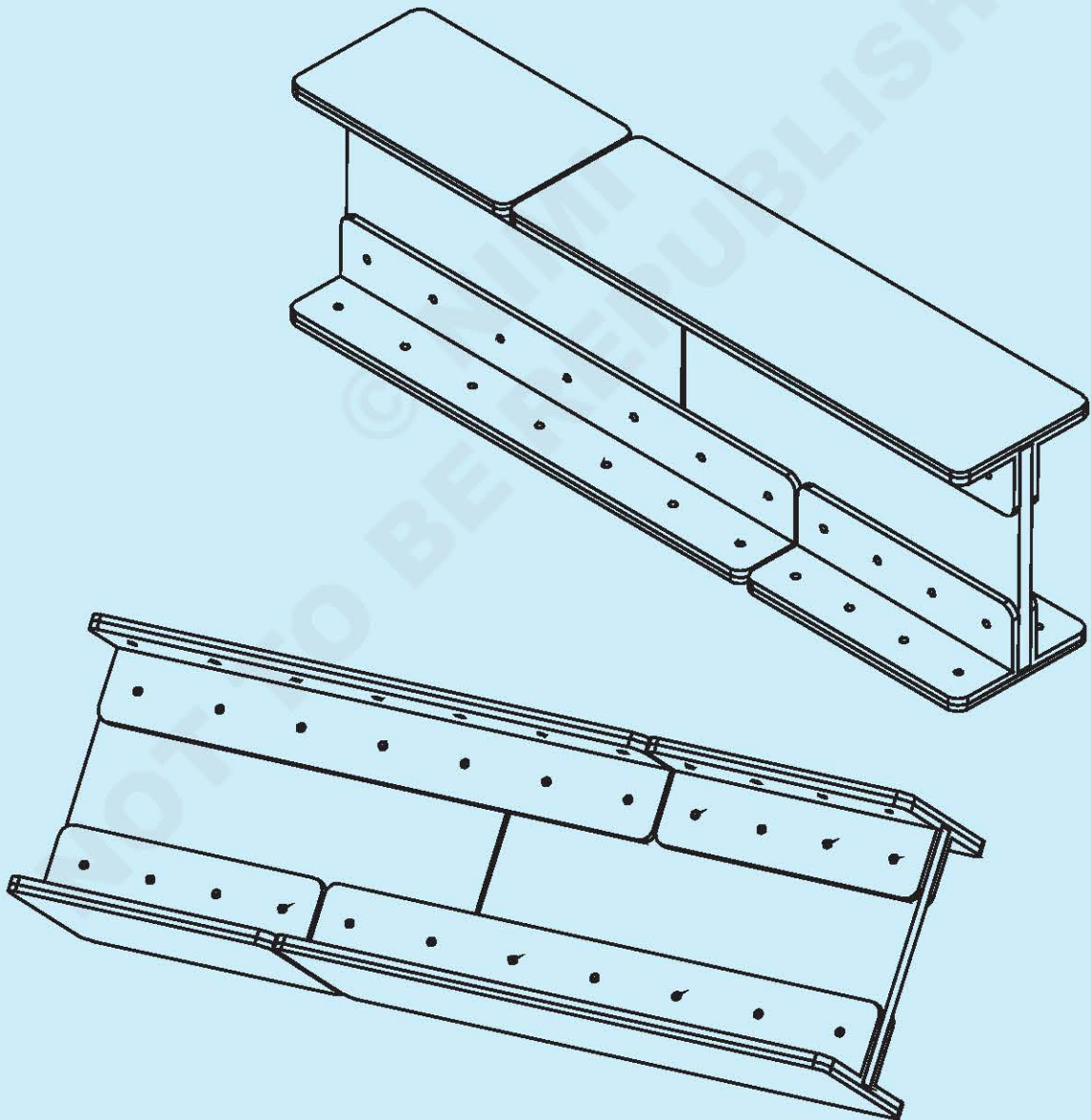

AFN2135H1

Job Sequence

- On a flat surface (e.g. surface plate), join one training beam with another one.
 - Hold them in place with 2 clamps.
 - Counter-drill holes and clamp.
 - Check the flushness and the gap.
 - Drill other holes and clamp.
 - Mark the workpieces by drawing marks with pencil.
 - Dismantle the parts and deburr.
 - Reassemble the workpieces with pins using the marks previously made.
 - Rivet all unclamped holes.
 - Remove the pins and finish riveting.
 - Check each rivet with a gauge.
- Use a shim to have the requested gap**
- Counter-drill holes at final diameter and clamp.

Complete the report sheet below

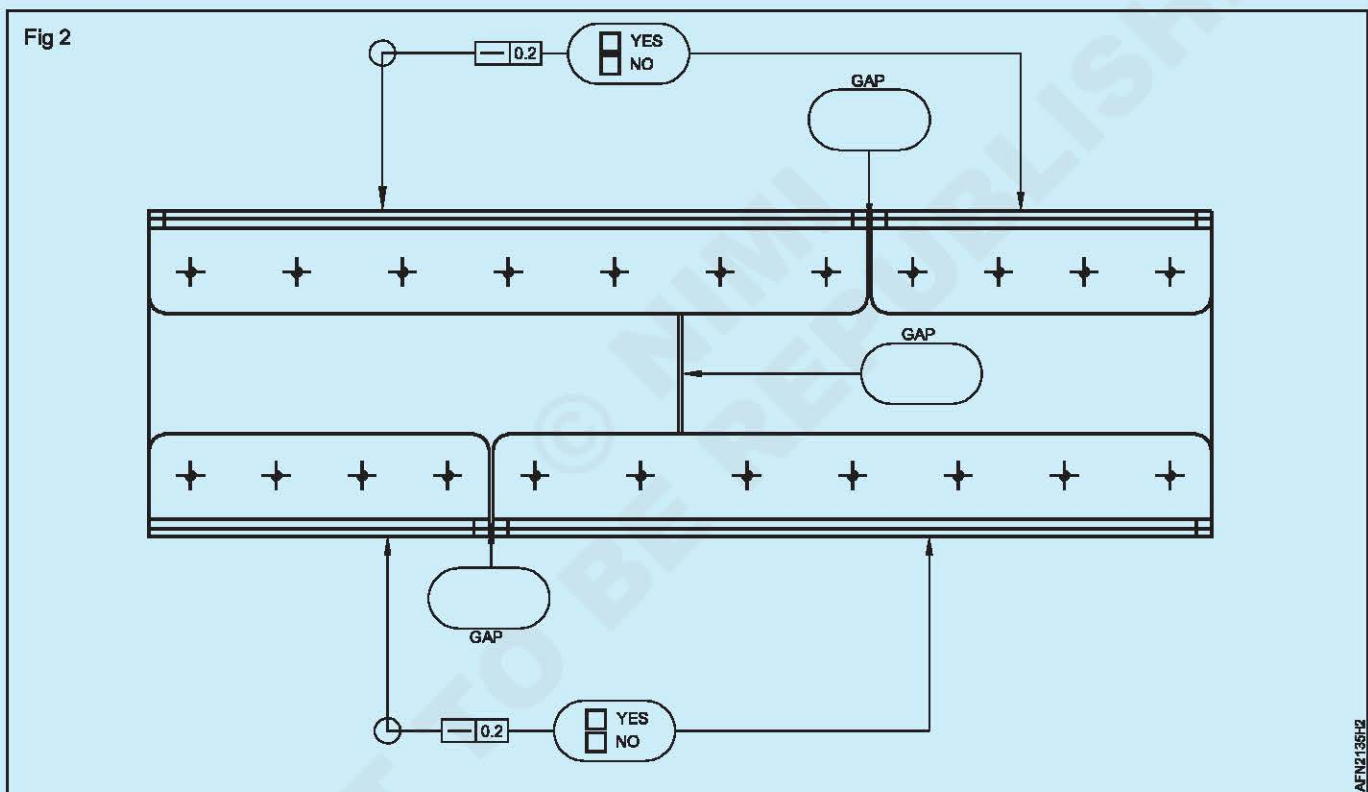

Parts assembly #01 - Flat pannel

Objectives: At the end of this exercise you shall be able to

- assemble parts.

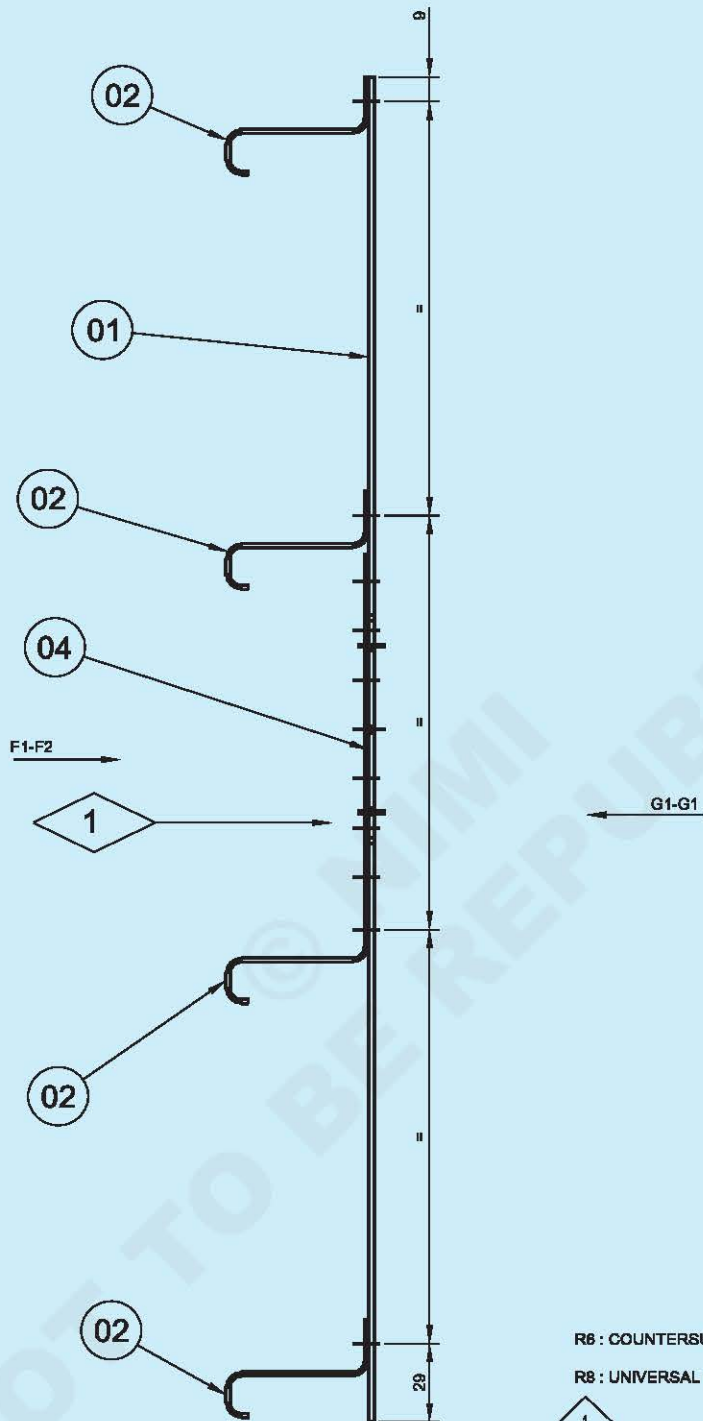

-	-	>2.1.34	-	-	-	2.1.35
NO.OFF	STOCK SIZE	SEMI-PRODUCT	MATERIAL	PROJECT NO.	PART NO.	EX. NO.
SCALE: NTS		FLAT PANEL ASSEMBLY - FOLIO 1			DEVIATIONS	TIME: 15HRS
					CODE NO : AFN2135E3	

G1-G1

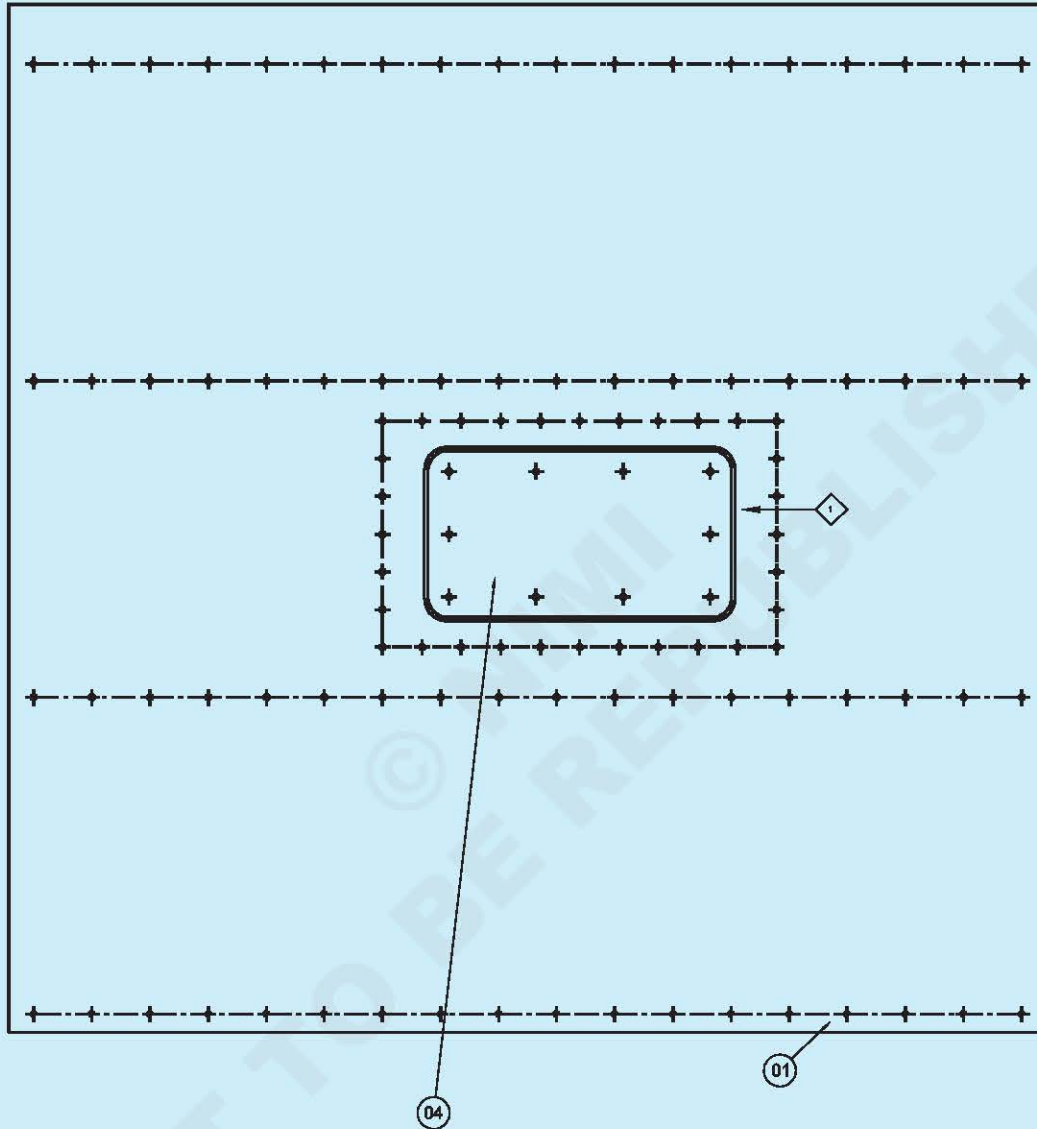

--	-	>2.1.34	-	--	-	2.1.35
NO.OFF	STOCK SIZE	SEMI-PRODUCT	MATERIAL	PROJECT NO.	PART NO.	EX. NO.
SCALE: NTS	FLAT PANEL ASSEMBLY - FOLIO 2				DEVIATIONS	TIME: 20HRS
					CODE NO : AFN2135E4	

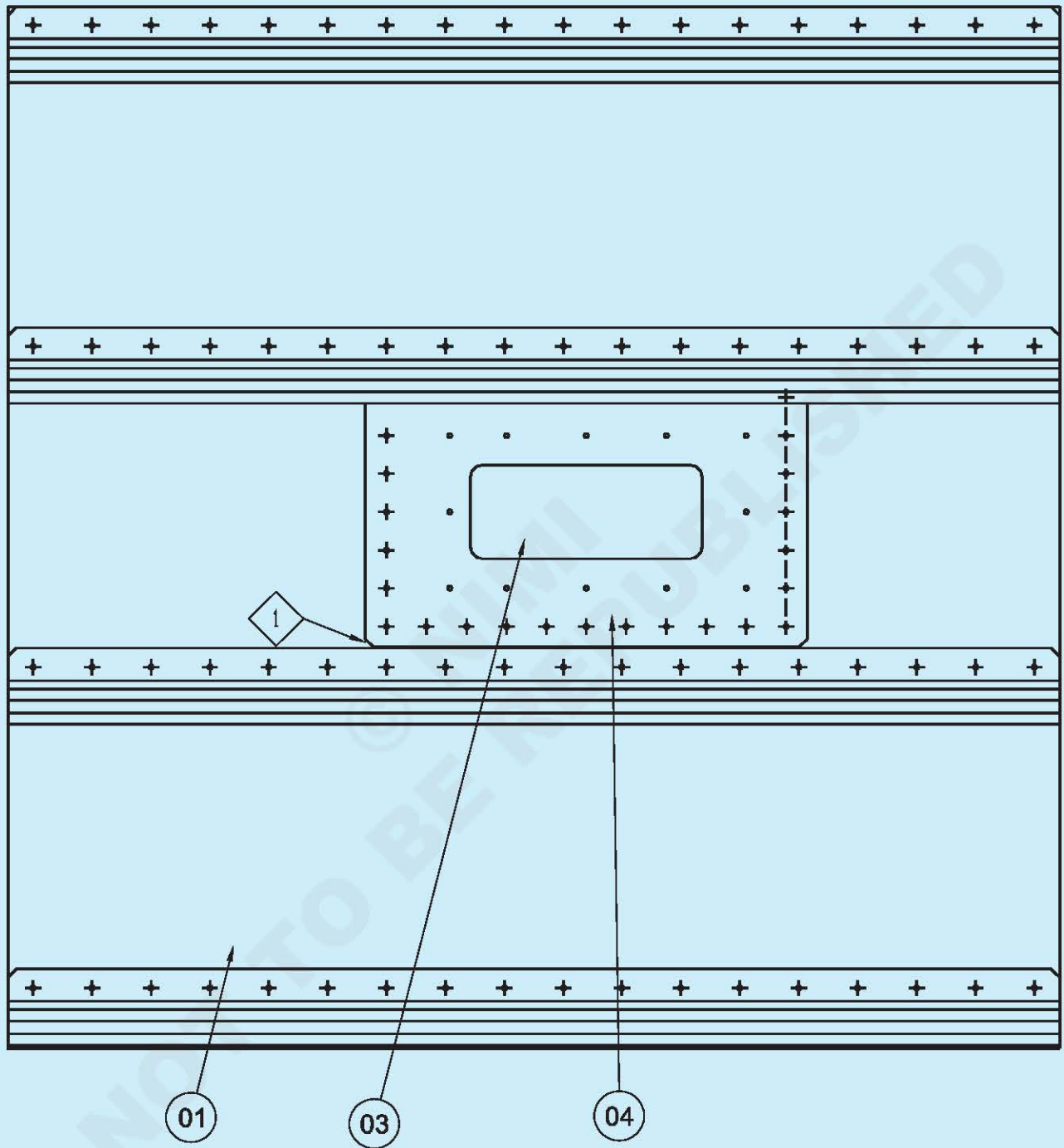

-	-	>2.1.34	-	-	--	2.1.35
NO.OFF	STOCK SIZE	SEMI-PRODUCT	MATERIAL	PROJECT NO.	PART NO.	EX. NO.
SCALE: NTS	FLAT PANEL ASSEMBLY - FOLIO 3				DEVIATIONS	TIME: 15HRS
					CODE NO : AFN2135E5	

Keys

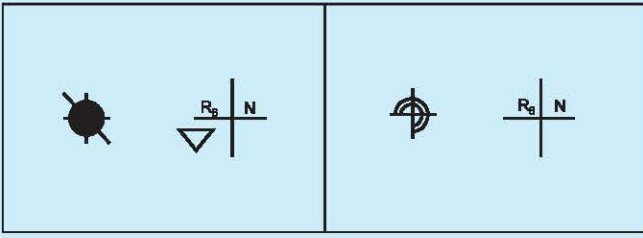

R6: Countersunk head rivet - 2117 material - 3.2 (1/8") diameter

R8: Universal head rivet - 2117 material - 3.2 (1/8") diameter

1 GAP - mini 1mm

PROCEDURE

Positioning of the stringers on the panel

Calculate the distance between each rivet axis for the location of the stringers.

In the inner part of the panel, draw the positioning lines corresponding to the rivet lines of each stringer.

Position each stringer on the lines. Look through the holes to see the line.

To ensure perpendicularity to the edge of the panel, use a square.

Hold in position with clamps.

Drill a few holes and pin.

Repeat for each of the stringers.

Counter-drill all the holes (diameter 2.5).

Positioning the door on the doubler

Position the door in the centre of the doubler. To help you, you can:

Possibility 1: trace the axes on both parts and position by aligning the lines.

Possibility 2: with a ruler or a depth gauge, draw the limits of the door. Position at the lines and check by measuring.

Hold in place with clamps.

Drill a few holes and pin.

Check positioning and counter-drill.

Positioning of the door/doubler sub-assembly with the panel

With the sub-assembly clamped properly, position in the cut-out of the panel.

Adjust the gaps so that they are identical on all sides.

You can use shims.

Block in position and counter-drill at the 4 corners.

Check the gap.

Check the clearance with the stringers. File if necessary.

Counter-drill the other holes.

Counter drilling to final diameter

Ensure a minimum 33% pin rate.

Counter-drill all holes to the final diameter.

Countersink the holes for the countersunk head rivets.

Identify the workpieces with pencil marks.

Dismantle all parts and deburr.

Reassemble and pin to 33%.

Riveting

Rivet the unpinned holes preferably starting from the centre of the workpiece.

Remove the pins and finish riveting.

Check.

Report by drawing the scratches, defects on rivets, etc. with a simple identification of the defect.

REPORT SHEET

Report by drawing the scratches, defects on rivets, etc. with a simple identification of the defect.

Fig 3

REPORT BY DRAWING THE SCRATCHES , DEFECTS ON RIVETS , ETC, WITH A SIMPLE IDENTIFICATION OF THE DEFECT

G1-G1

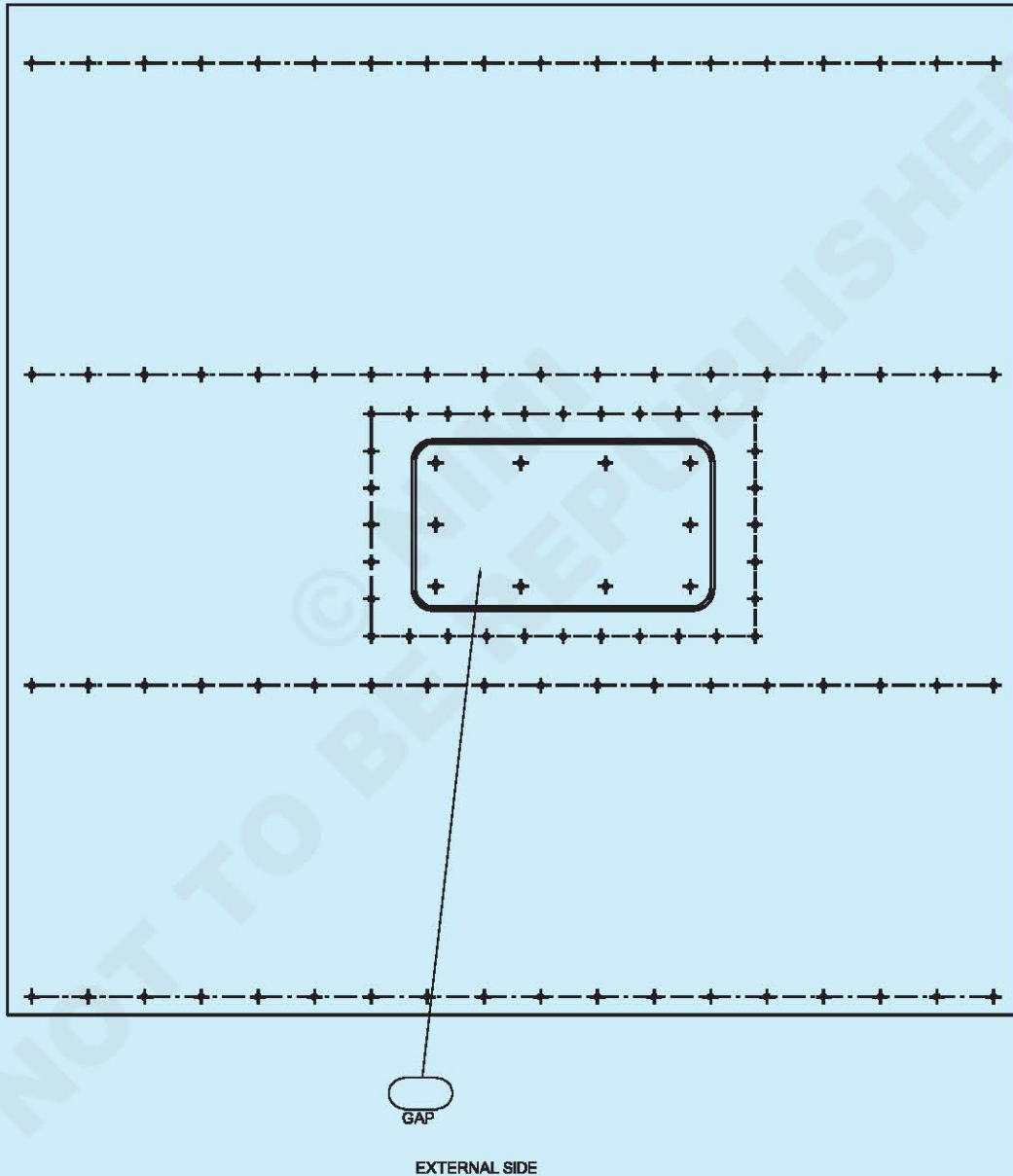

Report by drawing the scratches, defects on rivets, etc. with a simple identification of the defect.

Fig 4

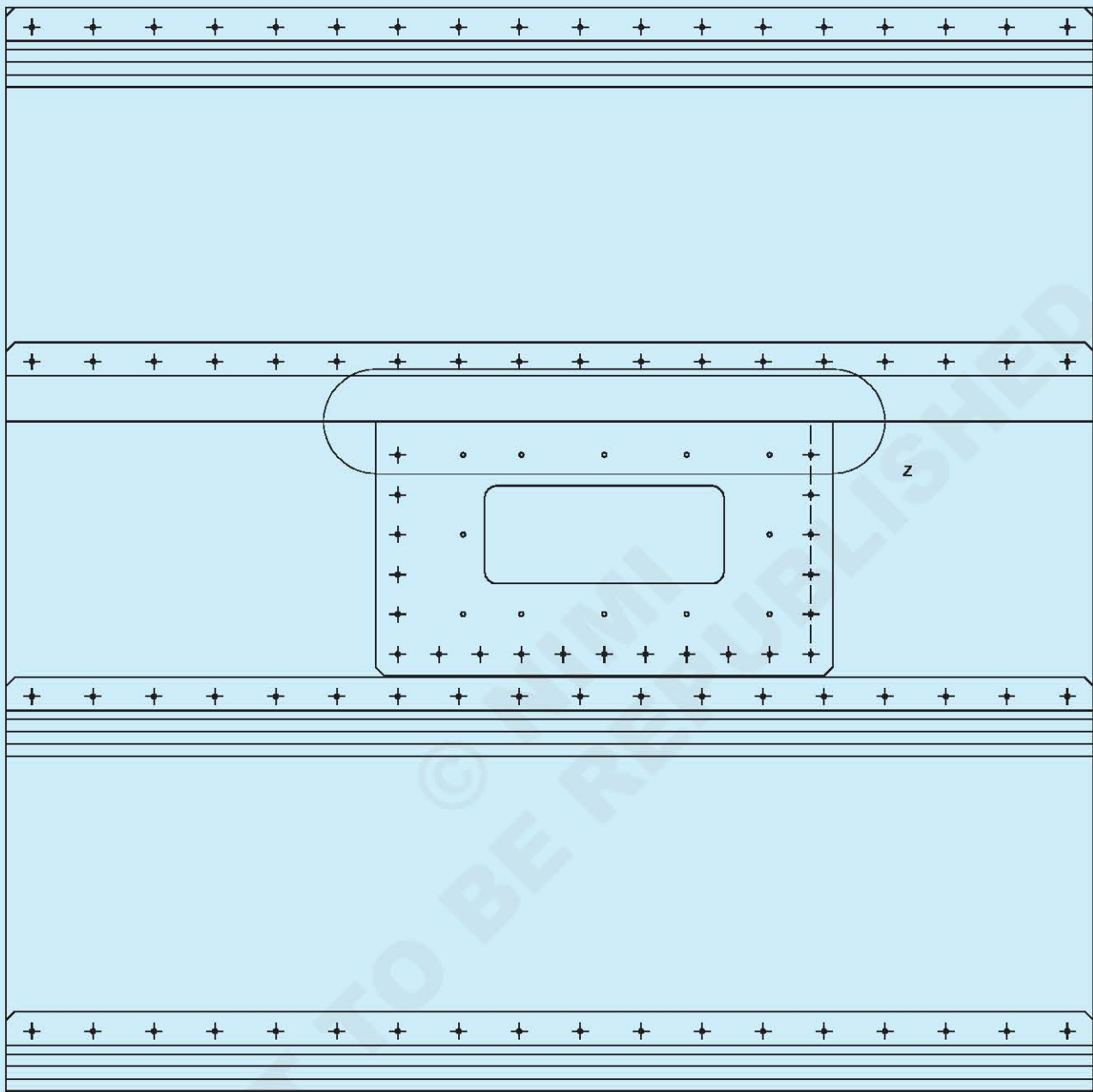

DETAIL - Z

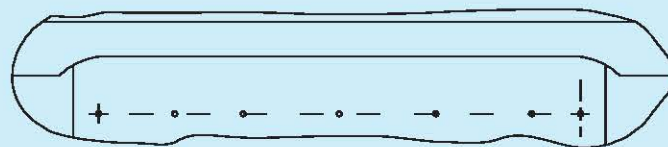

INTERNAL SIDE

AFN2135H

Fig 5

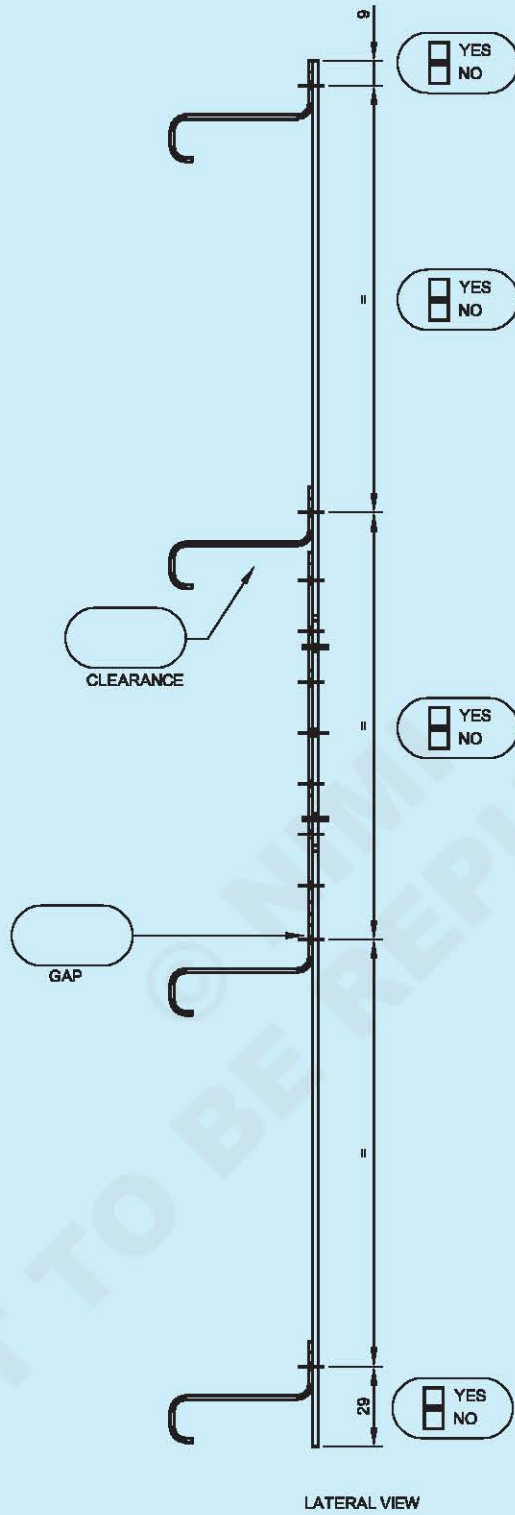

NOT TO BE REPUBLISHED

AFNZ136H5

Sealant application

Objectives: At the end of this exercise you shall be able to

- prepare surface to seal
- apply sealants.

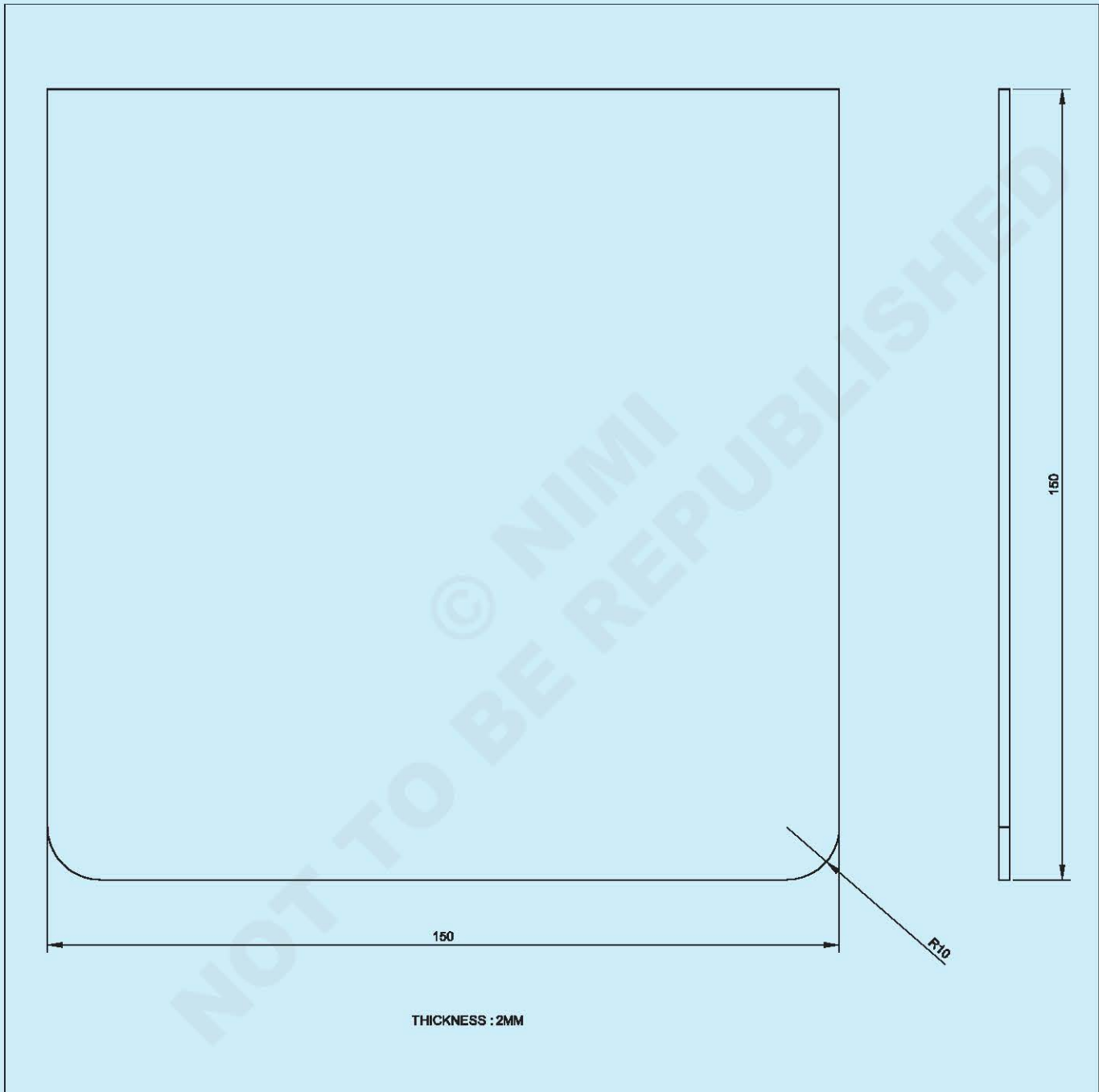

1	150X150 - 2MM	--	AW-2017	-	-	2.1.36
NO.OFF	STOCK SIZE	SEMI-PRODUCT	MATERIAL	PROJECT NO.	PART NO.	EX. NO.
SCALE: NTS		SEALANT APPLICATION MANUFACTURE ITEM 01			DEVIATIONS	TIME: 20HRS
					CODE NO : AFN2136E1	

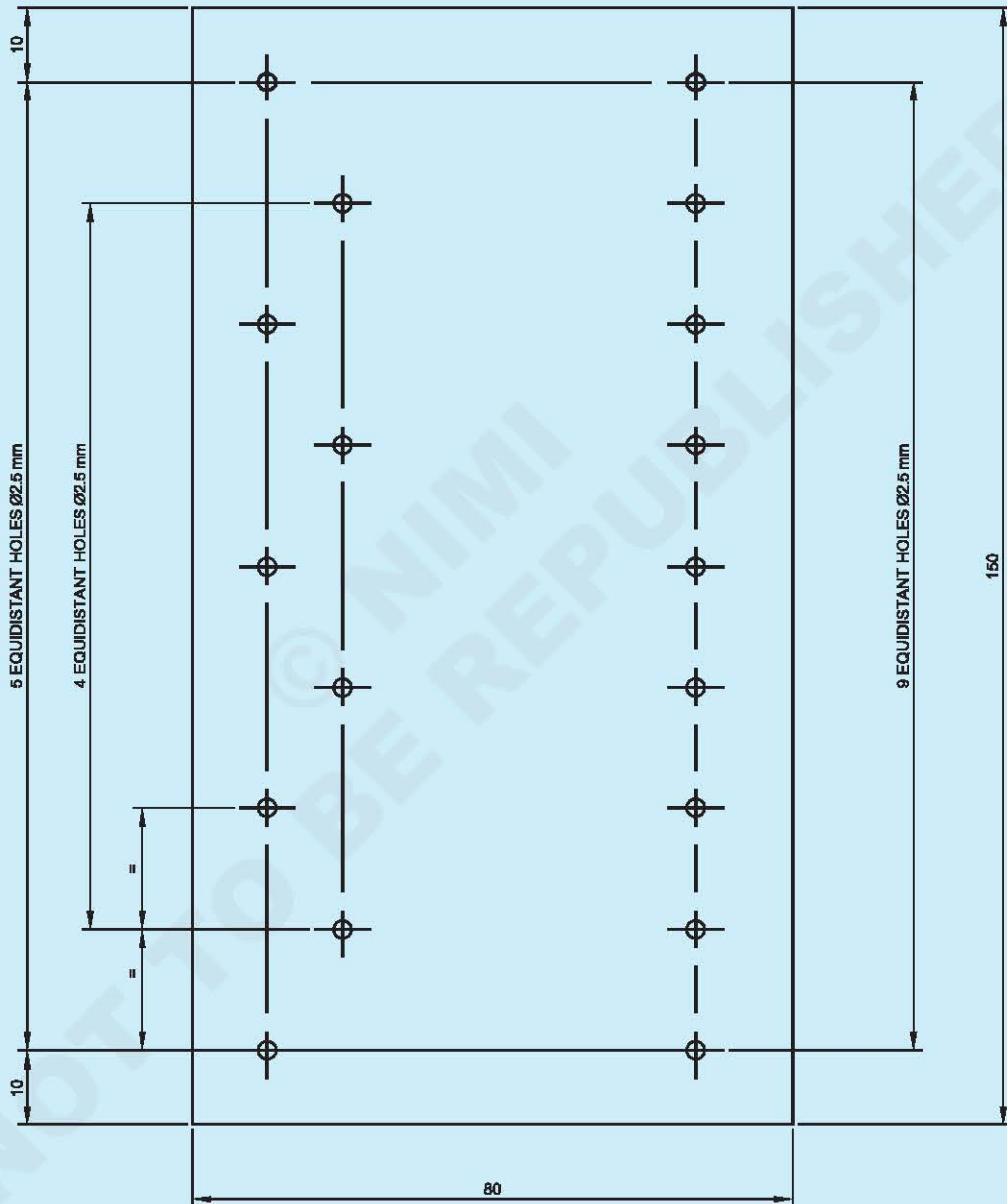

THICKNESS: 2MM

1	150X180 - 2MM	-	AW-2017	-	--	2.1.36
NO.OFF	STOCK SIZE	SEMI-PRODUCT	MATERIAL	PROJECT NO.	PART NO.	EX. NO.
SCALE: NTS	SEALANT APPLICATION MANUFACTURE ITEM 02				DEVIATIONS	TIME: 20HRS
					CODE NO : AFN2136E2	

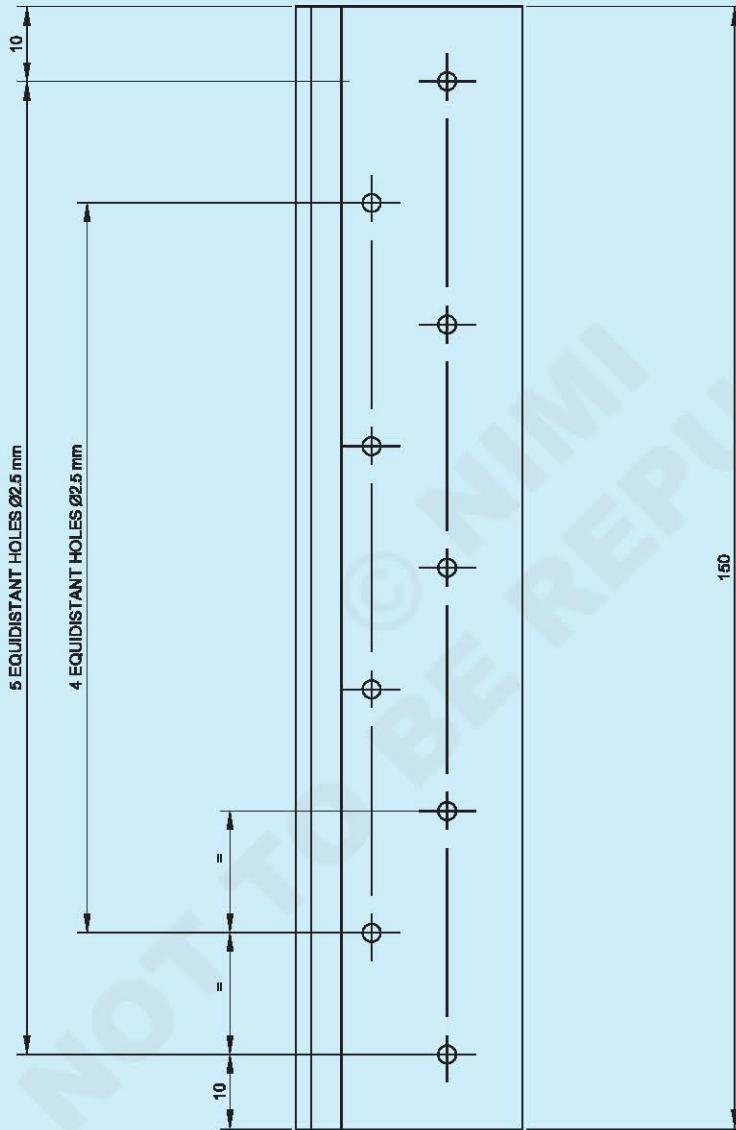
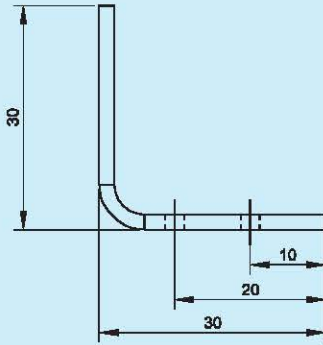

THICKNESS : 1.5MM
BENDING RADIUS: 4MM

1	150X60 - 2MM	--	AW-2017	--	-	2.1.36
NO.OFF	STOCK SIZE	SEMI-PRODUCT	MATERIAL	PROJECT NO.	PART NO.	EX. NO.
SCALE: NTS	SEALANT APPLICATION MANUFACTURE ITEM 03				DEVIATIONS	TIME: 20HRS
					CODE NO : AFN2136E3	

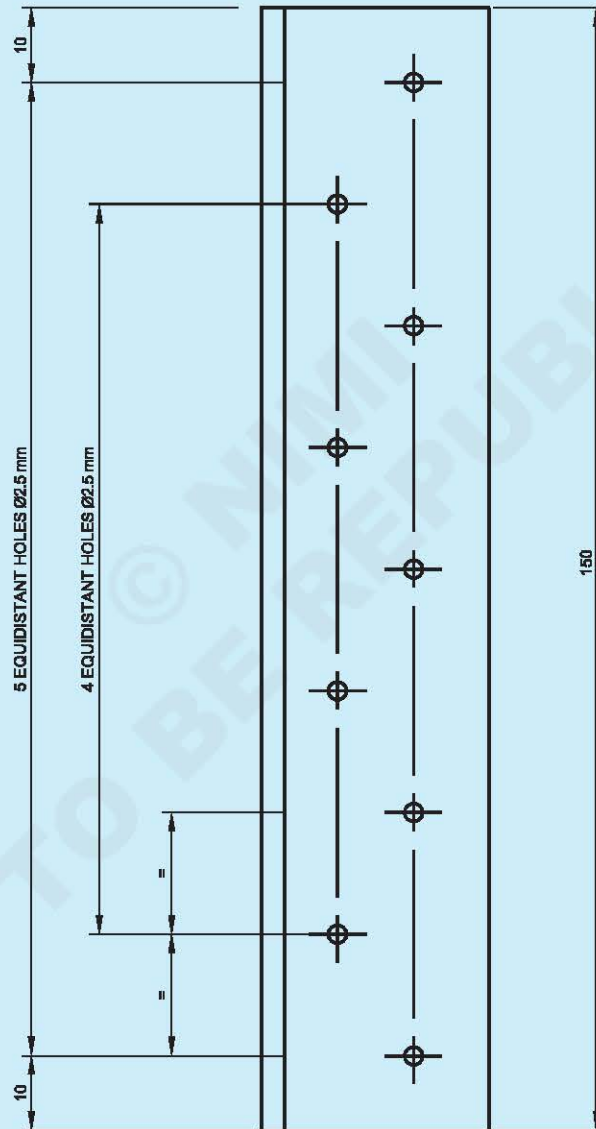
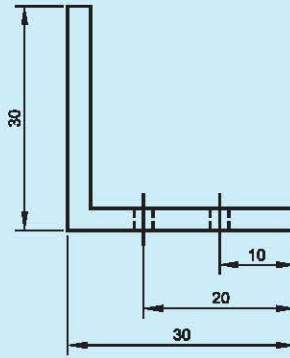

1	ANGLE 30X30X3 - 150	-	AW-2024	-	-	2.1.36
NO.OFF	STOCK SIZE	SEMI-PRODUCT	MATERIAL	PROJECT NO.	PART NO.	EX. NO.
SCALE: NTS	SEALANT APPLICATION MANUFACTURE ITEM 04				DEVIATIONS	TIME: 20HRS
					CODE NO : AFN2138E4	

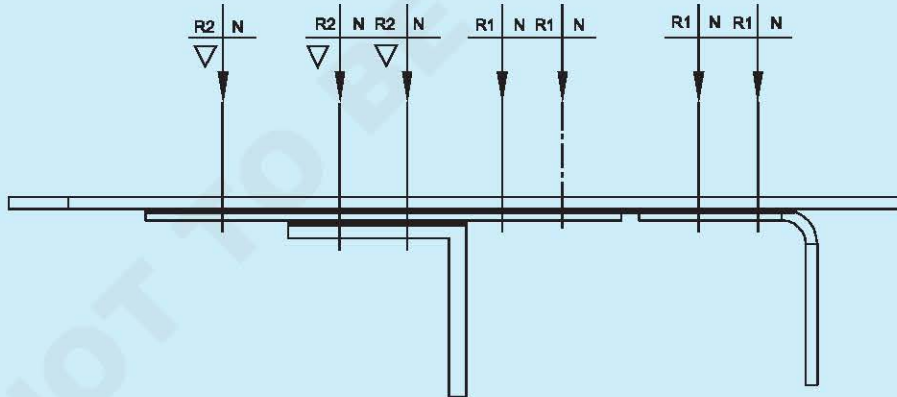
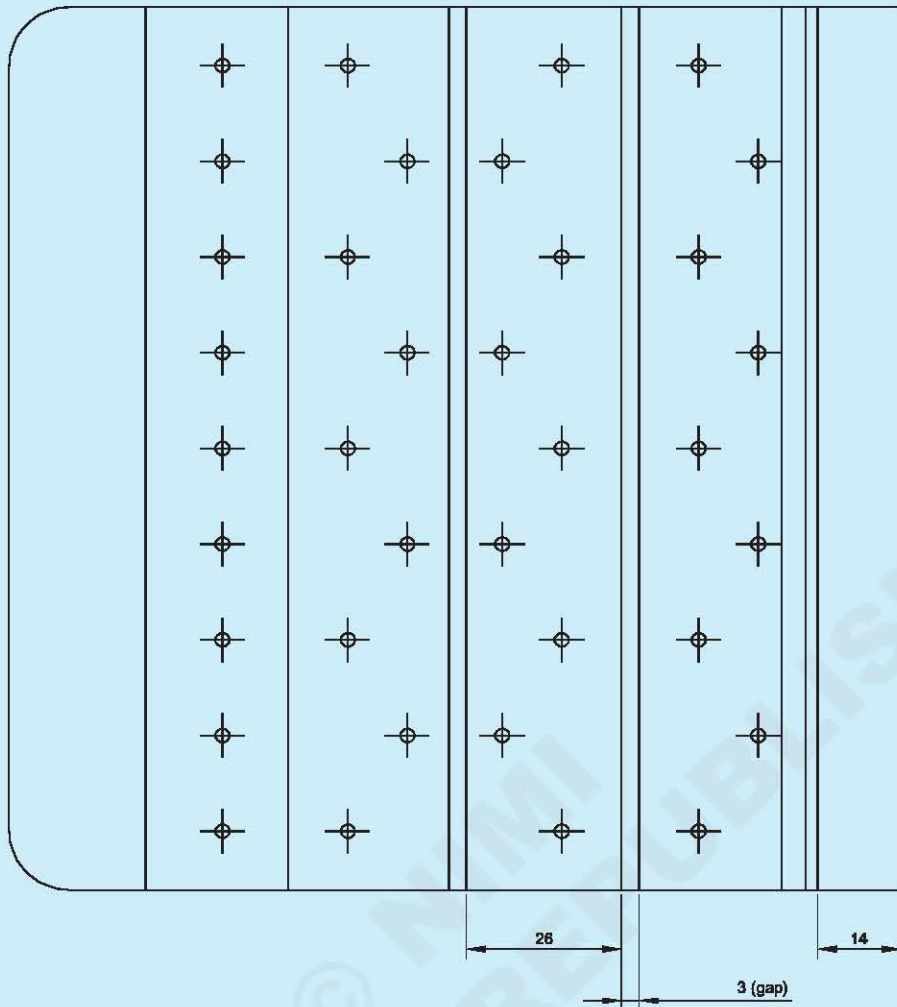

R1 : UNIVERSAL HEAD RIVET, 2117 MATERIAL, Ø3.2 mm (1/8")
 R2 : COUNTERSUNK HEAD RIVET, 2117 MATERIAL, Ø3.2 mm (1/8")

1	-	--	--	--	-	2.1.36
NO.OFF	STOCK SIZE	SEMI-PRODUCT	MATERIAL	PROJECT NO.	PART NO.	EX. NO.
SCALE: NTS	SEALANT APPLICATION ASSEMBLY				DEVIATIONS	TIME: 20HRS
					CODE NO : AFN2136E5	

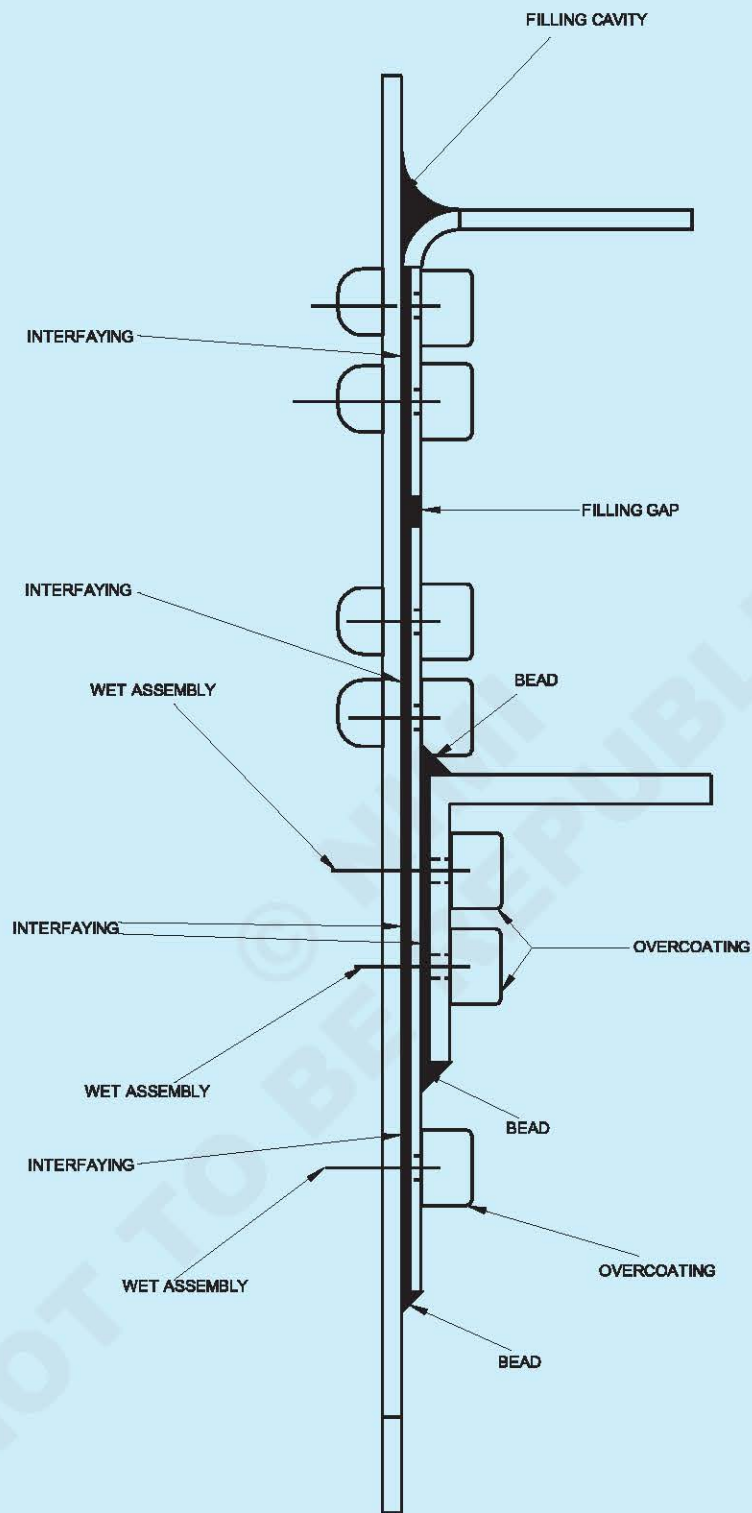

1	--	--	--	-	--	2.1.36
NO.OFF	STOCK SIZE	SEMI-PRODUCT	MATERIAL	PROJECT NO.	PART NO.	EX. NO.
SCALE: NTS	SEALANT APPLICATION SEALING				DEVIATIONS	TIME: 20HRS
					CODE NO : AFN2136E6	

PROCEDURE

TASK 1: Manufacturing parts

ITEM 01

Quantity: 1

- Check the parts.
- Mark external dimensions and radii.
- File and deburr edges.

ITEM 02

Quantity: 1

- Check the parts.
- Mark and file the external dimensions.
- Trace the hole lines.
- Drill the workpiece.
- Deburr.

ITEM 03

Quantity: 1

- Check the parts.

- Calculate the developed length.
- Adjust the external dimensions.
- Draw the bending lines.
- Bend the piece.
- Trace the hole lines.
- Drill the workpiece.
- Deburr.

ITEM 04

Quantity: 1

- Check the parts.
- Mark and file the external dimensions.
- Trace the hole lines.
- Drill the workpiece.
- Deburr.

REPORT SHEET

ITEM 01	CORRECT	<input type="checkbox"/> YES	<input type="checkbox"/> NO	REMARKS:
ITEM 02	CORRECT	<input type="checkbox"/> YES	<input type="checkbox"/> NO	REMARKS:
ITEM 03	CORRECT	<input type="checkbox"/> YES	<input type="checkbox"/> NO	REMARKS:
ITEM 04	CORRECT	<input type="checkbox"/> YES	<input type="checkbox"/> NO	REMARKS:

OBSERVATIONS:

TASK 2: Assembly

Positioning the parts

- Position angle item 03 to the correct distance, counter-drill and clamp in place.
- Position plate item 02 with gap, counter-drill and clamp.
- Position the angle item 04 to the correct distance, counter-drill and clamp.

Positioning the parts

- Position angle item 03 to the correct distance, counter-drill and clamp in place.
- Position plate item 02 with gap, counter-drill and clamp.
- Position the angle item 04 to the correct distance, counter-drill and clamp.

Counter drilling to final diameter

- Ensure a minimum 33% pin rate.
- Counter-drill all holes to the final diameter.
- Countersink the holes for the countersunk head rivets.
- Identify the workpieces with pencil marks.
- Dismantle all parts and deburr.

Surface preparation

- Prepare all surface following the instructions of the theory.

Do not touch prepared surfaces.

Interfay application

- Apply a thin layer of sealant with a roller to the surface in contact with item 01:

- The angle 03
- The plate 02
- The angle 04
- Pin in 100% and leave for 15 minutes.
- Remove 50% of the pins (one out of 2) and rivet.
- Remove the remaining pins and rivet.

NOTE:

Countersunk head rivets are installed wet. Put sealant in the countersink.

Beads, filling cavity and gap application

- With an extrusion gun, perform the beads.
- Smooth with a spatula.

You can limit the bead with tape paper.

Remove the tape immediately after smoothing. The direction for removing the tape is from the bead to the outside.

Overcoating application

- With a brush, make the coatings of the rivets.

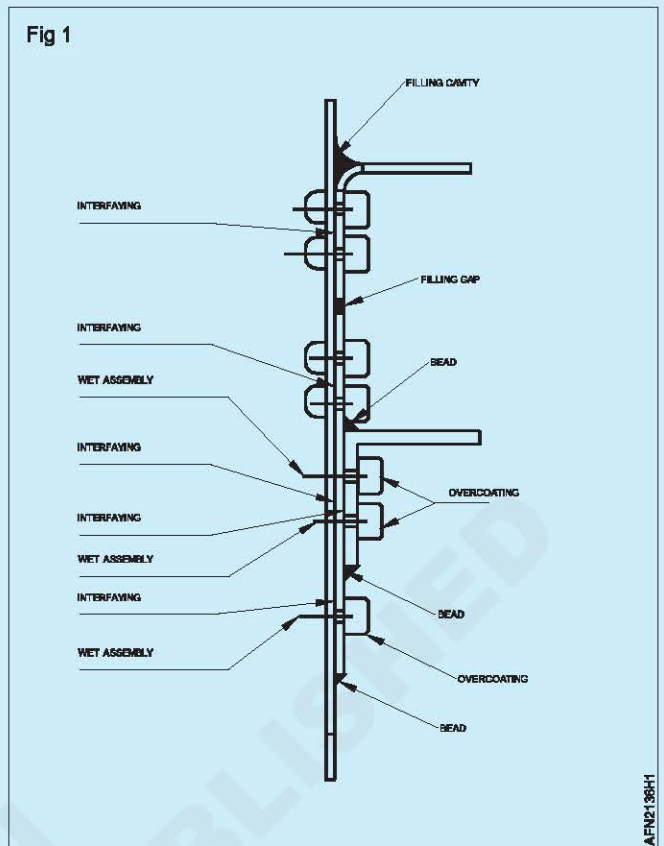

Sealant specimens

Objectives: At the end of this exercise you shall be able to

- manufacture sealant specimens
- make tensile test with sealant specimen.

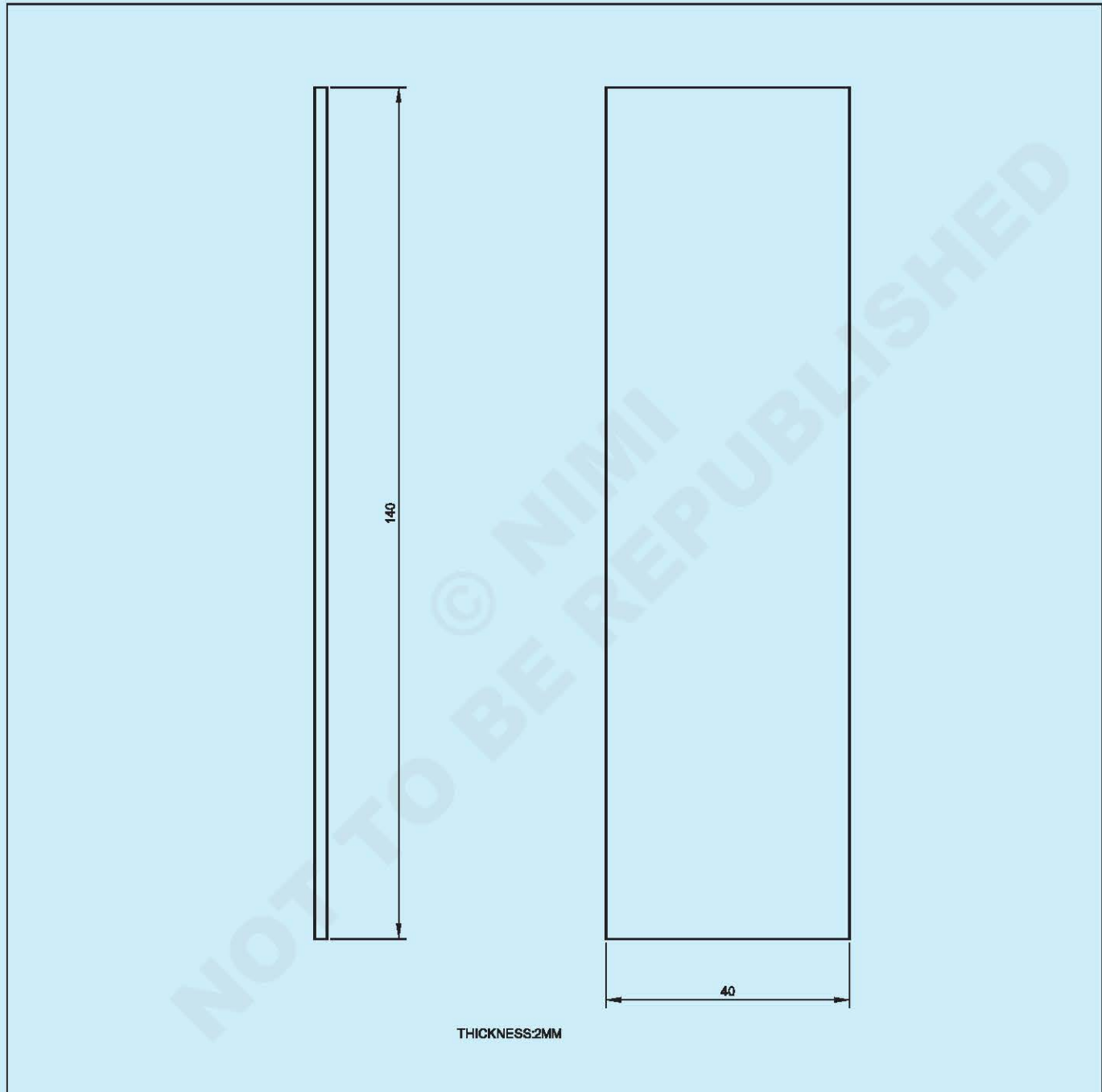

6	140X40 - 2MM	--	AW-2024	--	-	2.1.37
NO.OFF	STOCK SIZE	SEMI-PRODUCT	MATERIAL	PROJECT NO.	PART NO.	EX. NO.
SCALE: NTS	SEALANT SPECIMEN MANUFACTURING PARTS				DEVIATIONS	TIME: 20HRS
					CODE NO : AFN2137E1	

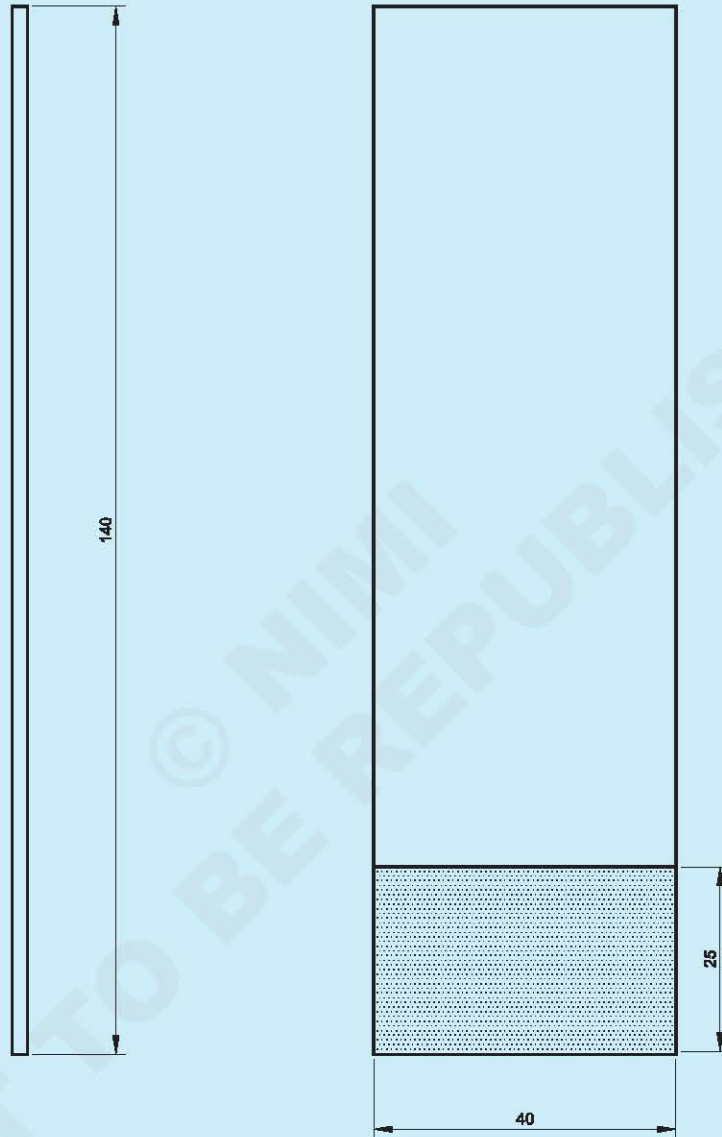

THICKNESS:2MM

6	--	-	-	-	-	2.1.37
NO.OFF	STOCK SIZE	SEMI-PRODUCT	MATERIAL	PROJECT NO.	PART NO.	EX. NO.
SCALE: NTS		SEALANT SPECIMEN SURFACE PREPARATION			DEVIATIONS	TIME: 20HRS
					CODE NO : AFN2137E2	

PROCEDURE

TASK 1: **Manufacturing parts**

Quantity: 6

- Check the parts.
- Mark and file.
- Deburr.
- Clean and degrease the surface.

- Abrade the surface.

Light abrasion using 320 grade paper or very fine non-woven nylon pad to produce a uniform matt surface finish.

- Final cleaning with solvent.
- Use the minimum quantity of cleaning agent.

TASK 2: **Specimens assembly**

- With roller, apply a thin layer of sealant on one part.
- Clamp with pliers the parts together.
- Wait the complete curing.

The squeezed-out sealant should be either smoothed.

TASK 3: **Tensile test**

- Perform a tensile test on each specimen.
- Analyse with the instructor the curves.

Sealant removal

Objectives: At the end of this exercise you shall be able to

- remove rivet
- check the hole after removal.

Job Sequence

- Remove all rivet marked by an arrow.
- Check the diameter after removal.
- Check the countersunk.

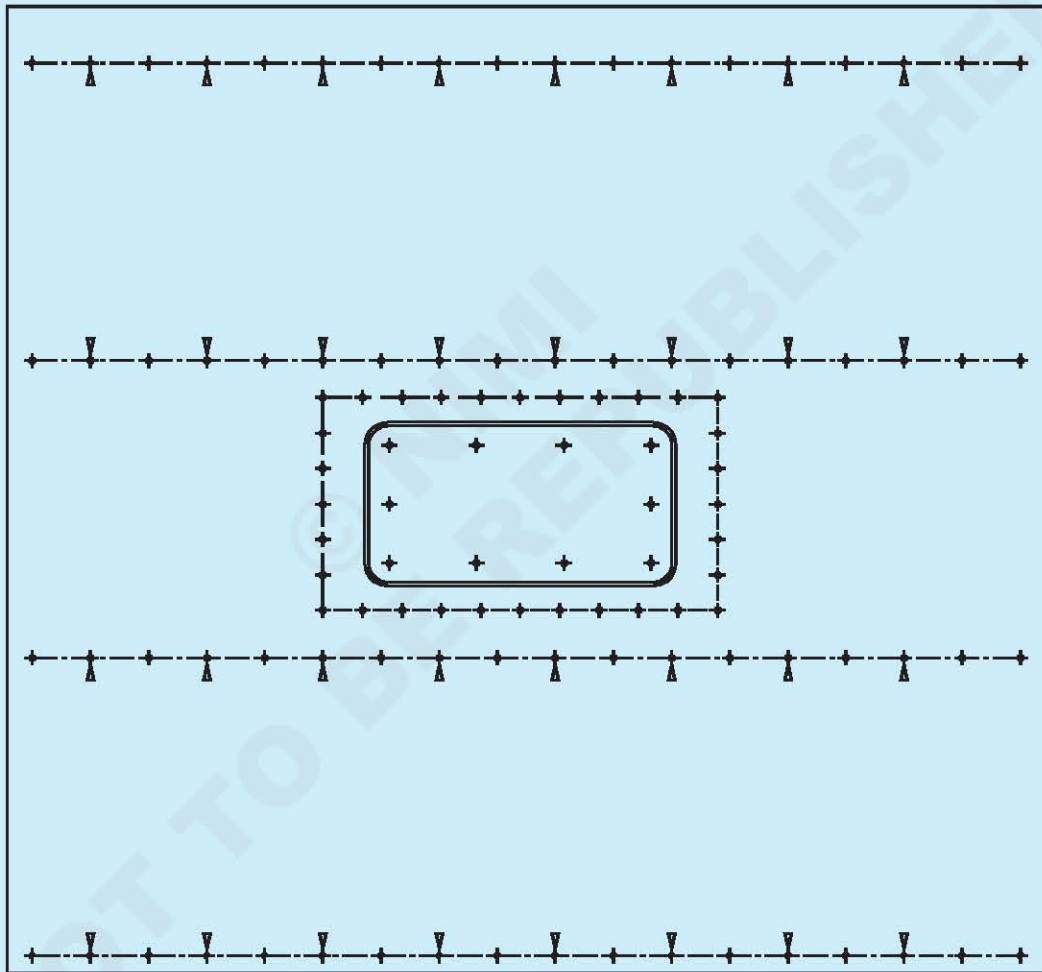

THICKNESS: 2MM

-	-	> 2.1.35	--	-	-	2.1.38
NO.OFF	STOCK SIZE	SEMI-PRODUCT	MATERIAL	PROJECT NO.	PART NO.	EX. NO.
SCALE: NTS	RIVET REMOVAL ON FLAT PANNEL				DEVIATIONS	TIME: 20HRS
					CODE NO : AFN2138E1	

Sheet metal forming

Objectives: At the end of this exercise you shall be able to

- form by shrinking and growing a plate
- form by shrinking and growing an angle.

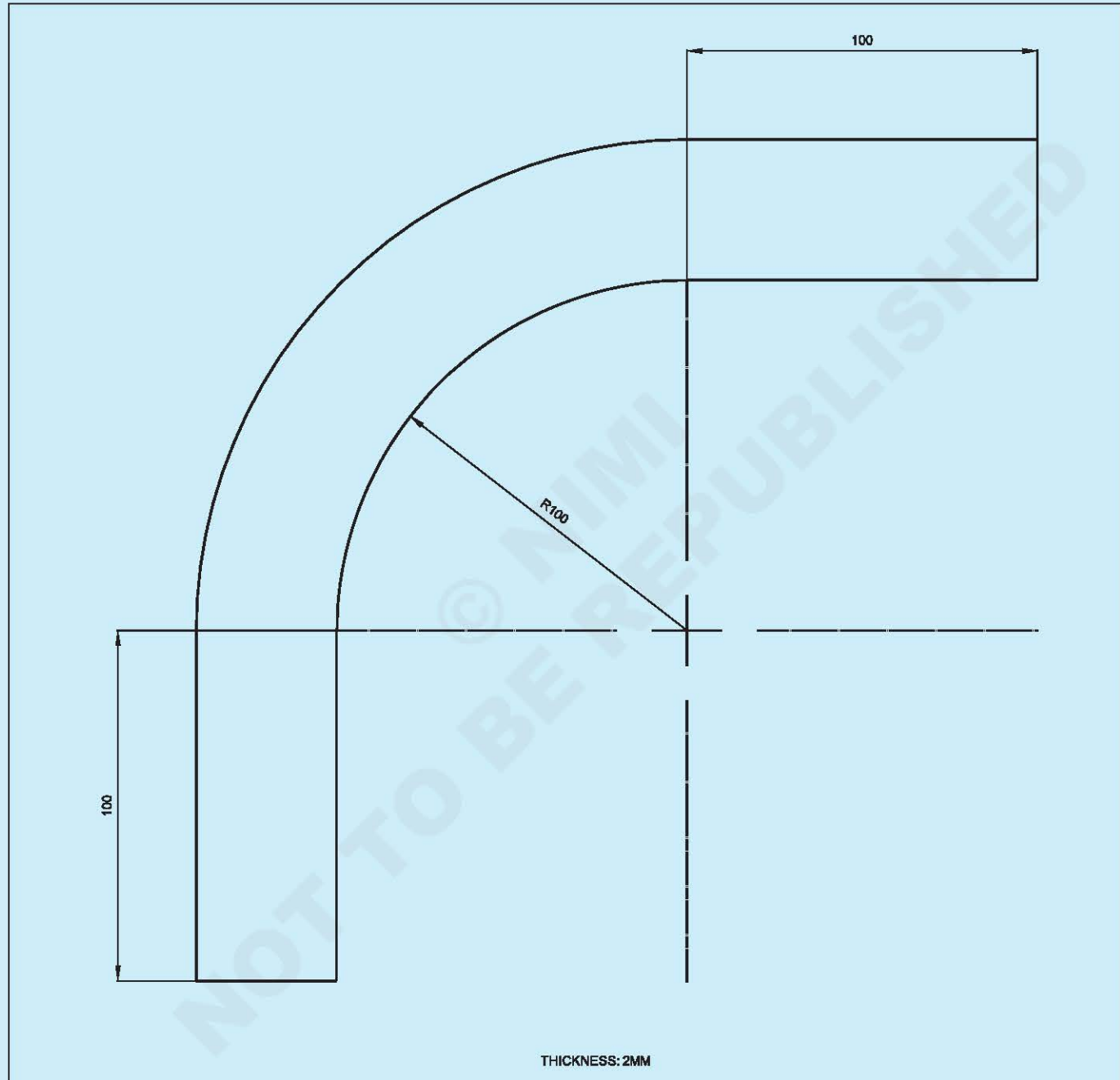

1	400x300 - 2MM	--	AW-5086	--	TASK 1	2.1.39
1	40X300 - 2MM	--	AW-2017	--	TASK 2	2.1.39
NO.OFF	STOCK SIZE	SEMI-PRODUCT	MATERIAL	PROJECT NO.	PART NO.	EX. NO.

SCALE: NTS	SHEET METAL FORMING FORMING PLATE BY GROWING AND SHRINKING	DEVIATIONS	TIME: 10HRS
		CODE NO : AFN2139E1	

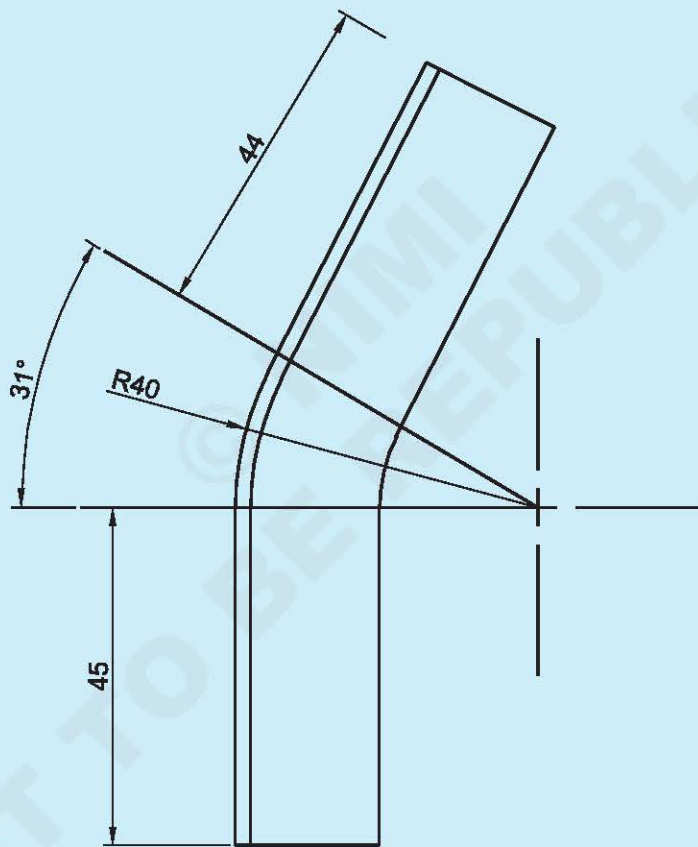
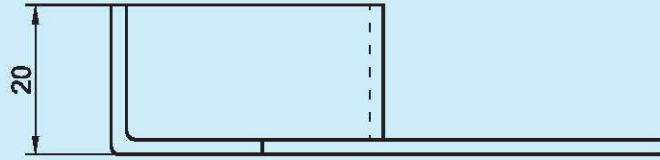

1	20X20X2 - 140MM	-	AW-6060	-	-	2.1.39
NO.OFF	STOCK SIZE	SEMI-PRODUCT	MATERIAL	PROJECT NO.	PART NO.	EX. NO.
SCALE: NTS	SHEET METAL FORMING FORMING ANGLE BY SHRINKING				DEVIATIONS	TIME: 5HRS
					CODE NO : AFN2139E2	

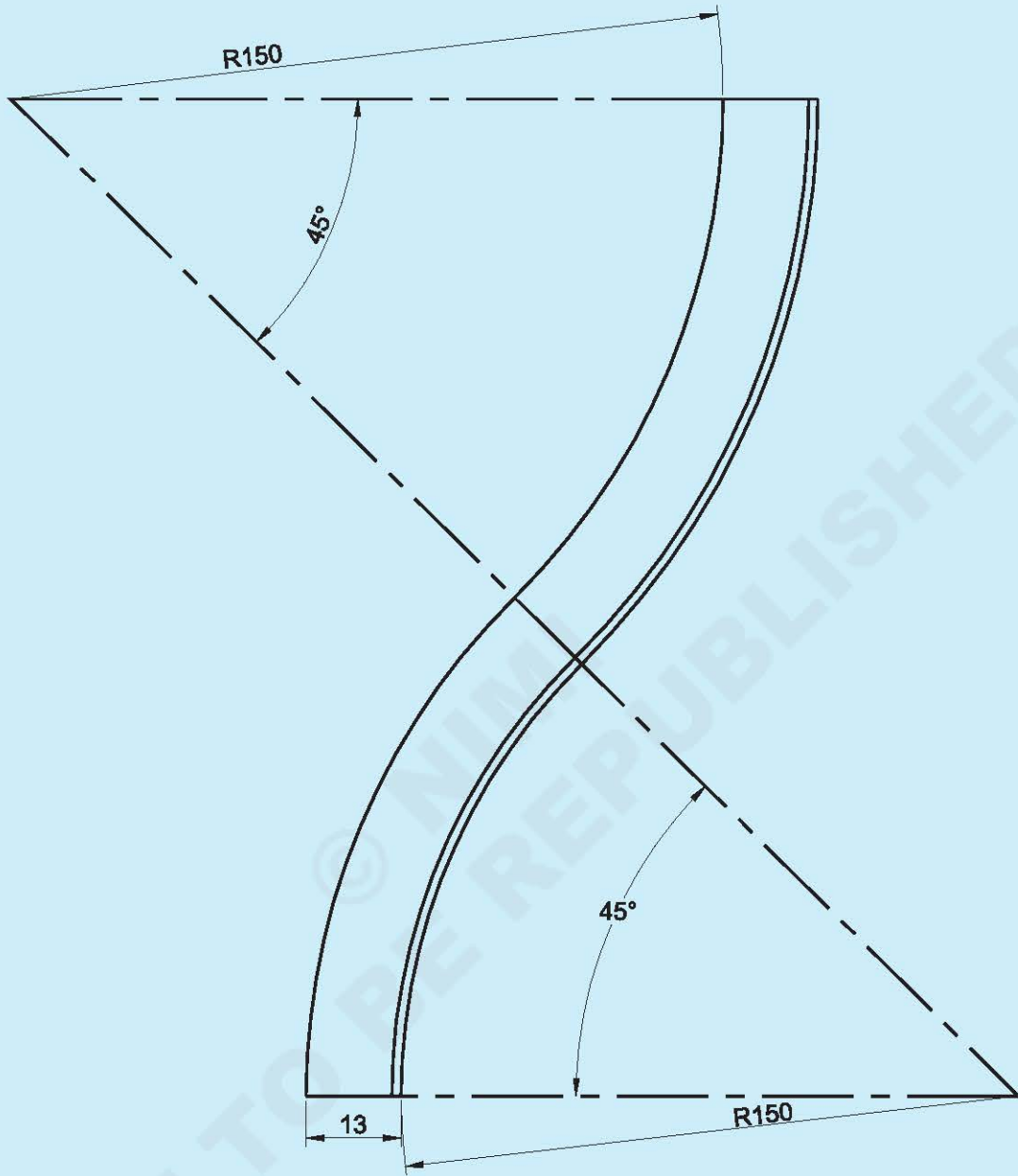

1	20X20X2 - 250MM	--	AW-6060	-	--	2.1.39
NO.OFF	STOCK SIZE	SEMI-PRODUCT	MATERIAL	PROJECT NO.	PART NO.	EX. NO.
SCALE: NTS		SHEET METAL FORMING FORMING ANGLE BY GROWING AND SHRINKING			DEVIATIONS	TIME: 5HRS
					CODE NO : AFN2139E3	

PROCEDURE

TASK 1: Forming plate

- On a sheet of paper, draw the required shape on a scale 1.
- Check the delivered stock.
- Adjust and deburr.
- Form the plate by growing and shrinking.
- Check regularly with the drawing.
- File to dimensions.
- Deburr.



TASK 2: Forming angle

(i) Forming angle by shrinking

- On a sheet of paper, draw the required shape on a scale 1.
- Check the delivered stock.
- Adjust and deburr.
- Form the plate by shrinking.
- Check regularly with the drawing.
- Check the perpendicularity and adjust if necessary, by opening or closing the angle flange.
- File to dimensions.
- Deburr.

(ii) Forming angle by growing and shrinking

- On a sheet of paper, draw the required shape on a scale 1.
- Check the delivered stock.
- Adjust and deburr.
- Form the plate by growing and shrinking.
- Check regularly with the drawing.
- Check the perpendicularity and adjust if necessary, by opening or closing the angle flange.
- File to dimensions.
- Deburr.



Manufacturing parts #01 - open box

Objectives: At the end of this exercise you shall be able to
 • **manufacture complex parts.**

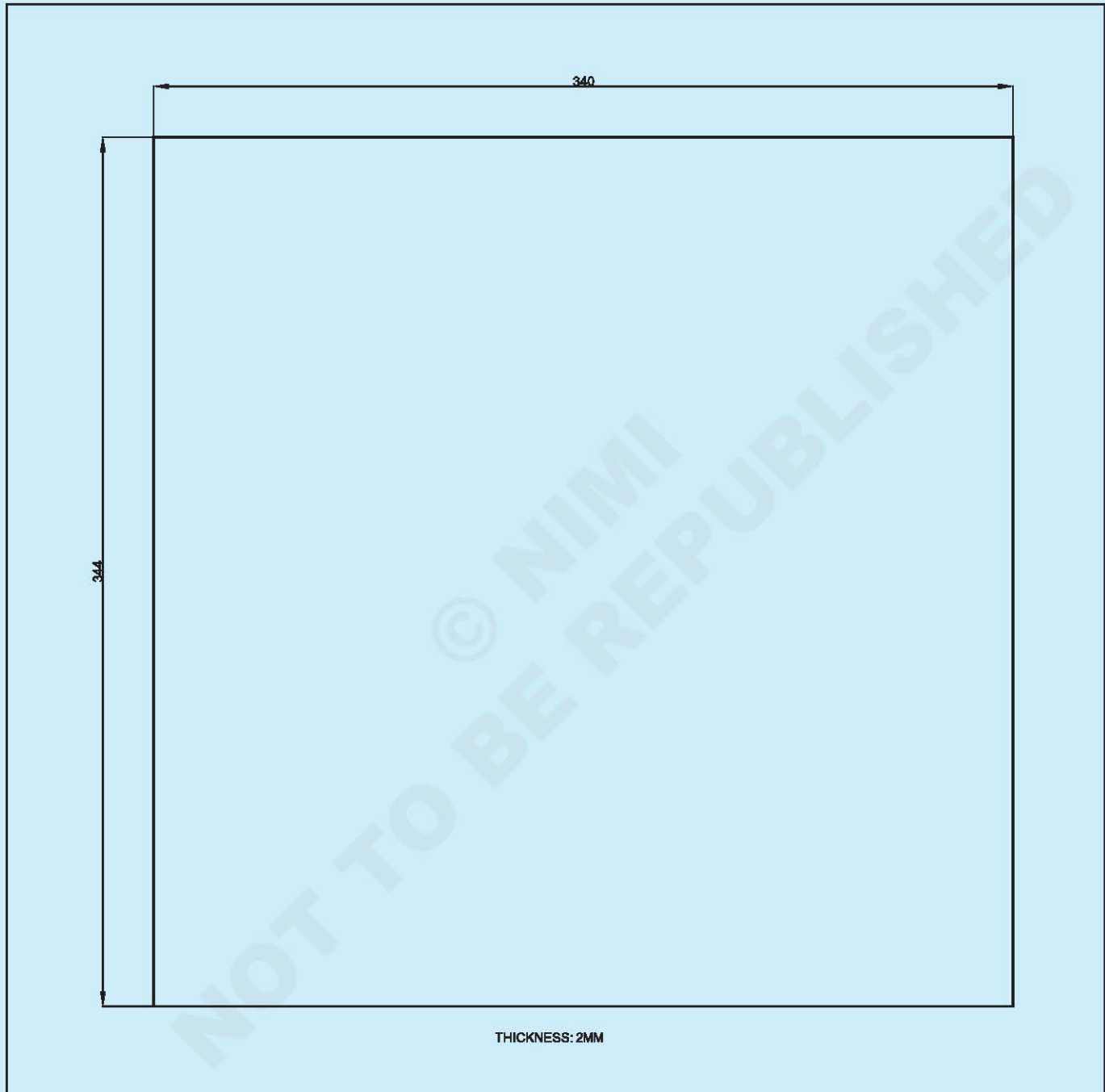

1	345X345X - 2MM	-	AW-2017	--	-	2.1.40
NO.OFF	STOCK SIZE	SEMI-PRODUCT	MATERIAL	PROJECT NO.	PART NO.	EX. NO.
SCALE: NTS	OPEN BOX - MANUFACTURING PARTS ITEM 01 - LOWER PANEL				DEVIATIONS	TIME: 1HRS
					CODE NO : AFN2140E1	

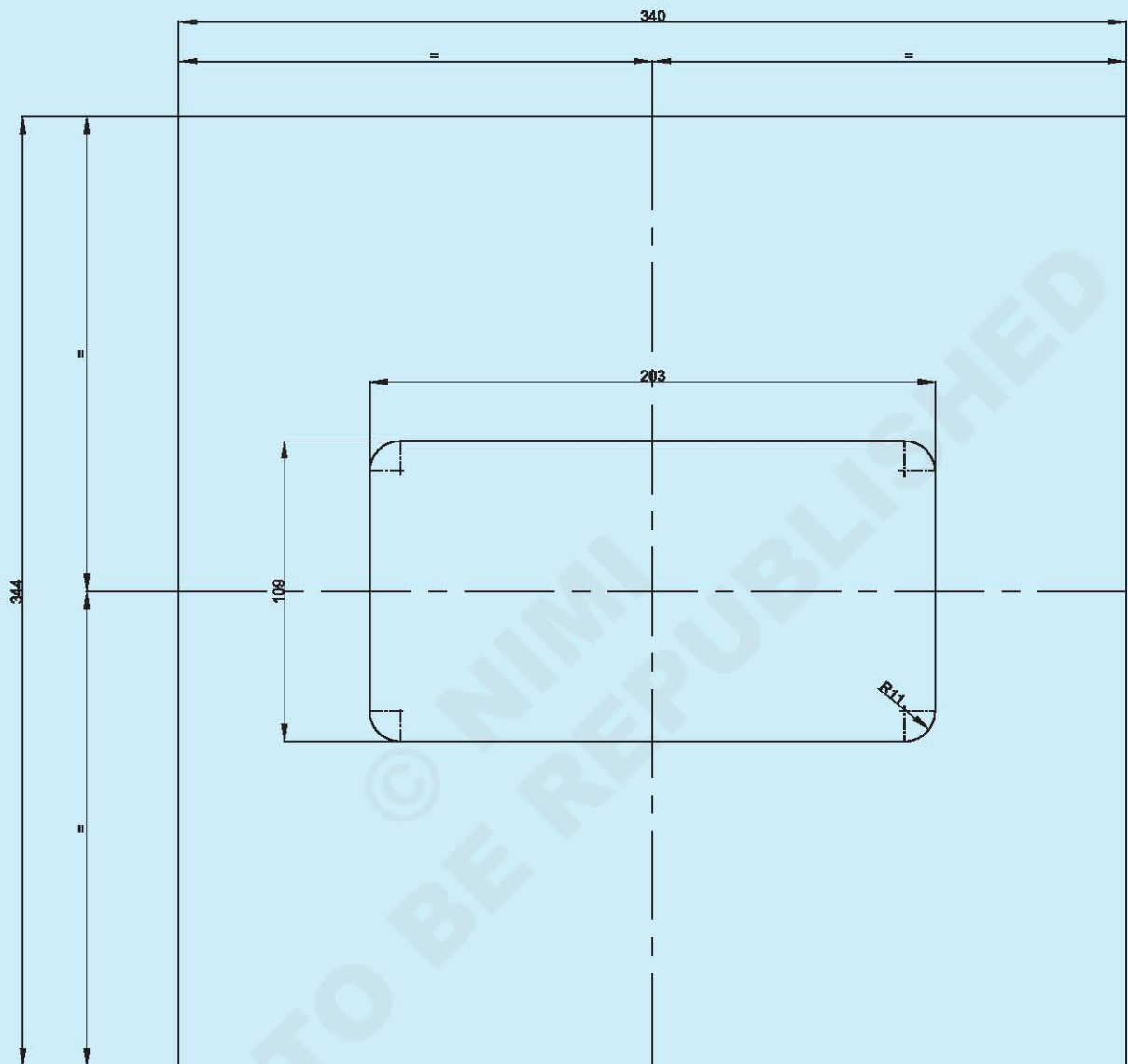

THICKNESS: 2MM

1	345X345X - 2MM	-	AW-2017	-	-	2.1.40
NO.OFF	STOCK SIZE	SEMI-PRODUCT	MATERIAL	PROJECT NO.	PART NO.	EX. NO.
SCALE: NTS	OPEN BOX - MANUFACTURING PARTS ITEM 02 - UPPER PANEL				DEVIATIONS	TIME: 3HRS
					CODE NO : AFN2140E2	

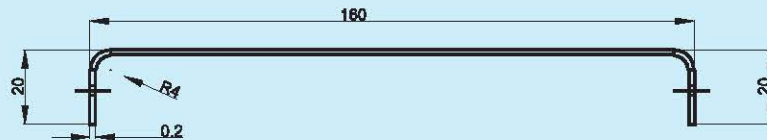
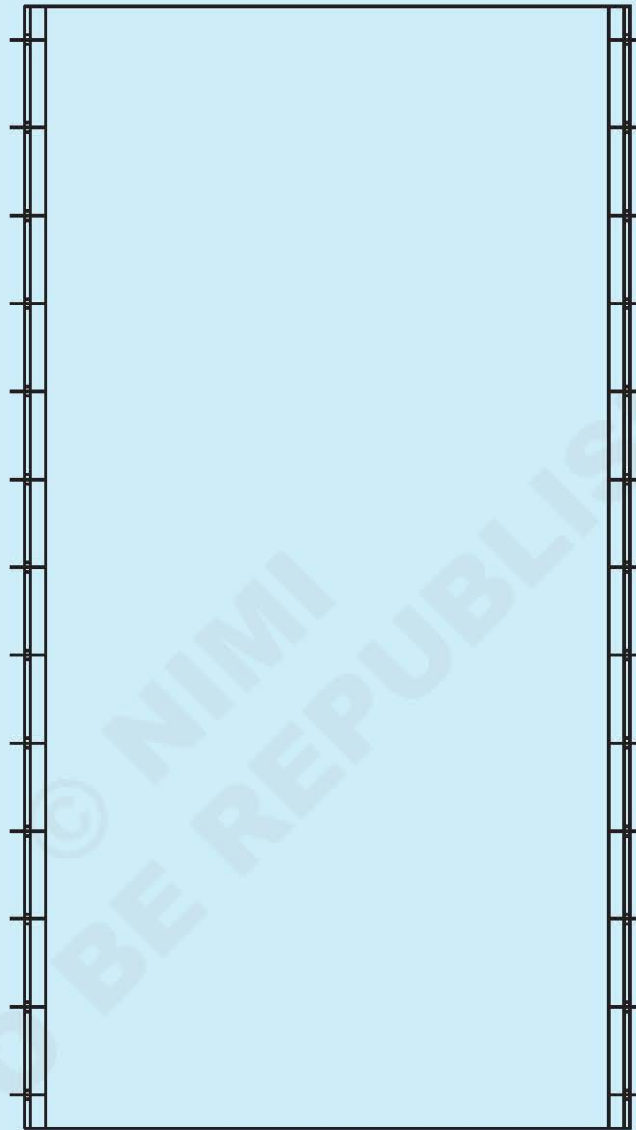
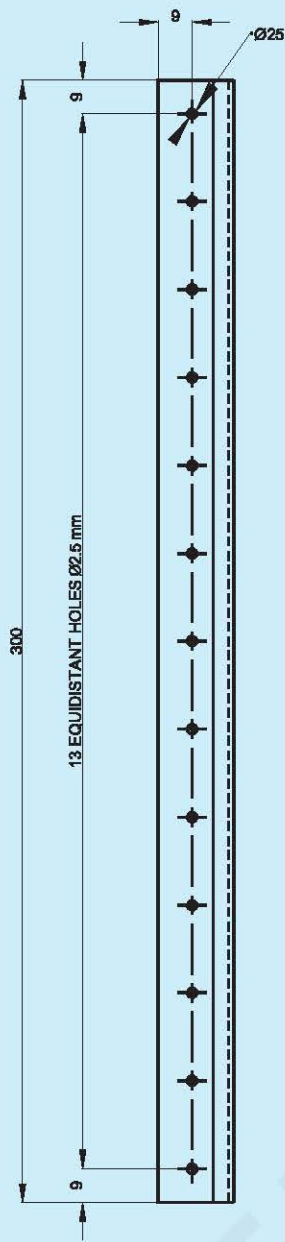

NOTE
SAME HOLES IN THE OTHER SIDE

1	345X345X - 2MM	-	AW-2017	-	-	2.1.40
NO.OFF	STOCK SIZE	SEMI-PRODUCT	MATERIAL	PROJECT NO.	PART NO.	EX. NO.
SCALE: NTS	OPEN BOX - MANUFACTURING PARTS ITEM 03 - LATERAL FLANGE				DEVIATIONS	TIME: 4HRS
					CODE NO : AFN2140E3	

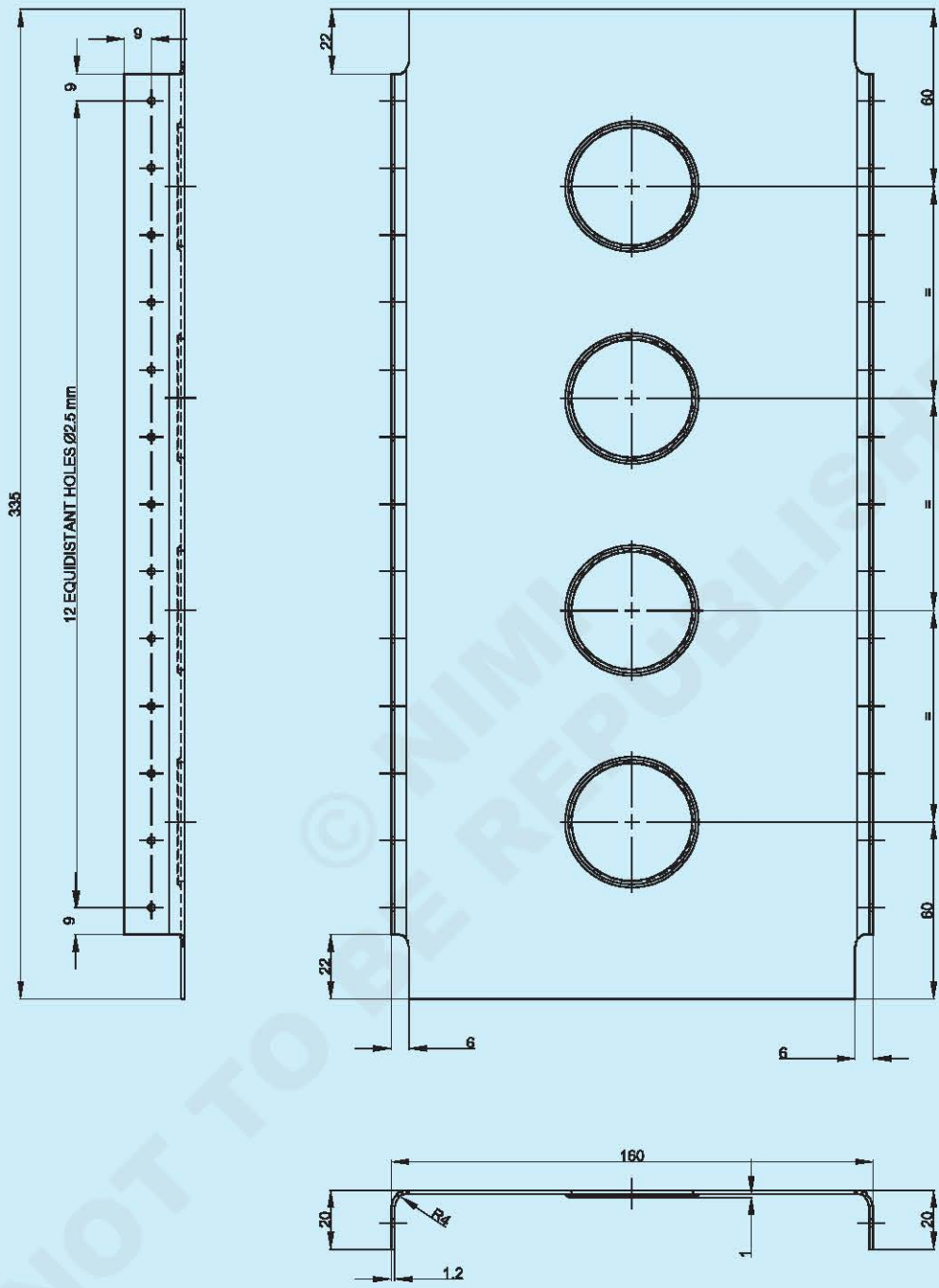

NOTE:
 SAME HOLES IN THE OTHER SIDE
 FLANGED HOLE DIAMETER: 40MM

2	335X205X - 2MM	--	AW-2017	-	-	2.1.40
NO.OFF	STOCK SIZE	SEMI-PRODUCT	MATERIAL	PROJECT NO.	PART NO.	EX. NO.
SCALE: NTS	OPEN BOX - MANUFACTURING PARTS ITEM 04 - INTERNAL PANEL				DEVIATIONS	TIME: 8HRS
					CODE NO : AFN2140E4	

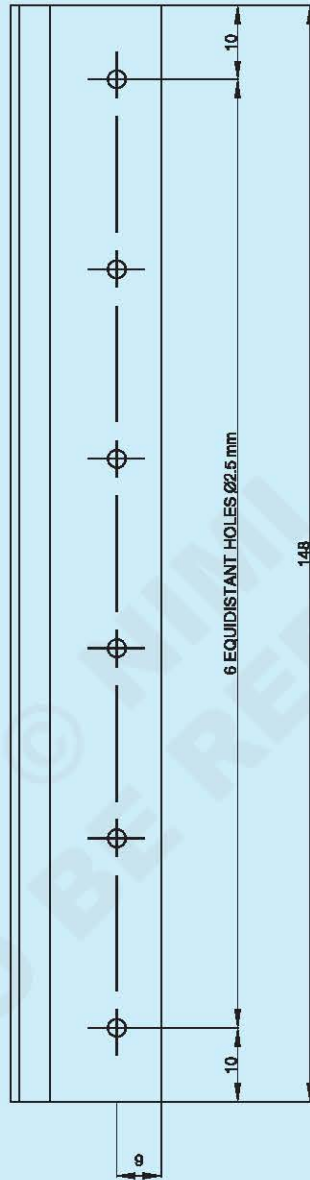
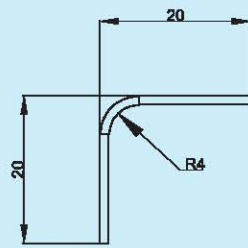

NOTE
Same holes in the other side

4	150X45 - 1.2MM	-	AW-2017	-	-	2.1.40
NO.OFF	STOCK SIZE	SEMI-PRODUCT	MATERIAL	PROJECT NO.	PART NO.	EX. NO.
SCALE: NTS		OPEN BOX - MANUFACTURING PARTS ITEM 05 - ANGLE			DEVIATIONS	TIME: 4HRS
					CODE NO : AFN2140E5	

PROCEDURE

Manufacturing item 01

- Check dimensions and thickness.
- Mark and file external dimensions.
- Finish edges by draw filing.
- Deburr edges.

Manufacturing item 02

- Check dimensions and thickness.
- Mark and file external dimensions.
- Finish edges by draw filing.
- Deburr edges.
- Trace the cut-out.
- Drill the angles.
- Cut with a hacksaw and file.
- Finish edges by draw filing and deburr.

Manufacturing item 03

- Check dimensions and thickness.
- Calculate the developed length.
- Mark and file external dimensions calculated above.
- Finish edges by draw filing.
- Deburr edges.
- Bend the angles using brake.
- Check the angle and the dimensions. File if necessary.
- Mark the holes positions.
- Punch the centre of the holes.

Drilling diameter 2.5

- Hold the workpiece and drill holes with hand drill.
- Deburr both sides.
- Check diameter and perpendicularity of each hole.

Manufacturing item 04

- Check dimensions and thickness.
- Calculate the developed length.
- Mark and file external dimensions calculated above.

- Finish edges by draw filing.
- Deburr edges.
- Bend the angles using brake.
- Check the angle and the dimensions. File if necessary.
- Mark the holes positions.
- Punch the centre of the holes.

Drilling diameter 2.5

- Hold the workpiece and drill holes with hand drill.
- Deburr both sides.
- Check diameter and perpendicularity of each hole.
- Mark the angle cut-out positions.
- Drill diameter 4 the angles.
- Cut with a hacksaw and file.
- Finish edges by draw filing and deburr.
- Mark the flanged holes positions.
- Punch the centre of the holes.
- Drill the centre and make flanged holes with press.
- Deburr

Manufacturing item 05

- Check dimensions and thickness.
- Calculate the developed length.
- Mark and file external dimensions calculated above.
- Finish edges by draw filing.
- Deburr edges.
- Bend the angles using brake.
- Check the angle and the dimensions. File if necessary.
- Mark the holes positions.
- Punch the centre of the holes.

Drilling diameter 2.5

- Hold the workpiece and drill holes with hand drill.
- Deburr both sides.
- Check diameter and perpendicularity of each hole.

REPORT SHEET – ITEM 01 – LOWER PANEL

Dimensions	Theoretical		Measured
	External dimensions	340	
344		±0.5	

Deburring quality CONFORM NOT CONFORM
 Absence of marks, impacts or scratches CONFORM NOT CONFORM

Observations:

REPORT SHEET – ITEM 02 – UPPER PANEL

Dimensions	Theoretical		Measured
	External dimensions	340	
344		±0.5	
Cut-out dimensions	109	±0.5	
	203	±0.5	
	R11	±0.5	

Deburring quality CONFORM NOT CONFORM
 Absence of marks, impacts or scratches CONFORM NOT CONFORM

Observations:

REPORT SHEET – ITEM 03 – LATERAL FLANGE

PART NUMBER 1

Dimensions	Theoretical		Measured
	Flange	20	
Angle	90°	±0.5°	
Length	300	±0.5	
Height	160	±0.5	

Drilling	Theoretical		Measured
	Edge distance	9	
Number of holes	13 + 13		
Drilling quality	-		<input type="checkbox"/> OK <input type="checkbox"/> NOK
Deburring quality	-		<input type="checkbox"/> OK <input type="checkbox"/> NOK

Deburring quality CONFORM NOT CONFORM
 Absence of marks, impacts or scratches CONFORM NOT CONFORM

Observations:

REPORT SHEET – ITEM 03 – LATERAL FLANGE

PART NUMBER 2

Dimensions	Theoretical		Measured
Flange	20	±0.5	
Flange	20	±0.5	
Angle	90°	±0.5°	
Length	300	±0.5	
Height	160	±0.5	

Drilling	Theoretical		Measured
Edge distance	9	+1 / -0	
Number of holes	13 + 13		
Drilling quality	-		<input type="checkbox"/> OK <input type="checkbox"/> NOK
Deburring quality	-		<input type="checkbox"/> OK <input type="checkbox"/> NOK

Deburring quality

CONFORM

NOT CONFORM

Absence of marks, impacts or scratches

CONFORM

NOT CONFORM

REPORT SHEET – ITEM 04 – INTERNAL FLANGE

PART NUMBER 1

Dimensions	Theoretical		Measured
Flange	20	±0.5	
Flange	20	±0.5	
Angle	90°	±0.5°	
Length	335	±0.5	
Height	160	±0.5	
Cut-out 1	22 x 6	±0.5	
Cut-out 2	22 x 6	±0.5	
Cut-out 3	22 x 6	±0.5	
Cut-out 4	22 x 6	±0.5	

Flanged hole	Theoretical		Measured
Centered	80	±0.5	
Position first hole	60	±0.5	
Position last hole	60	±0.5	
Number of holes	4		
Pressing quality	-		<input type="checkbox"/> OK <input type="checkbox"/> NOK
Height of flanges	See standard		<input type="checkbox"/> OK <input type="checkbox"/> NOK

Drilling	Theoretical		Measured
Edge distance	9	+1 / -0	
Number of holes	12 + 12		
Drilling quality	-		<input type="checkbox"/> OK <input type="checkbox"/> NOK
Deburring quality	-		<input type="checkbox"/> OK <input type="checkbox"/> NOK

Deburring quality

CONFORM

NOT CONFORM

Absence of marks, impacts or scratches

CONFORM

NOT CONFORM

REPORT SHEET – ITEM 04 – INTERNAL FLANGE

PART NUMBER 2

Dimensions	Theoretical		Measured
Flange	20	±0.5	
Flange	20	±0.5	
Angle	90°	±0.5°	
Length	335	±0.5	
Height	160	±0.5	
Cut-out 1	22 x 6	±0.5	
Cut-out 2	22 x 6	±0.5	
Cut-out 3	22 x 6	±0.5	
Cut-out 4	22 x 6	±0.5	

Flanged hole	Theoretical		Measured
Centred	80	±0.5	
Position first hole	60	±0.5	
Position last hole	60	±0.5	
Number of holes	4		
Pressing quality	-		<input type="checkbox"/> OK <input type="checkbox"/> NOK
Height of flanges	See standard		<input type="checkbox"/> OK <input type="checkbox"/> NOK

Drilling	Theoretical		Measured
Edge distance	9	+1 / -0	
Number of holes	12 + 12		
Drilling quality	-		<input type="checkbox"/> OK <input type="checkbox"/> NOK
Deburring quality	-		<input type="checkbox"/> OK <input type="checkbox"/> NOK

Deburring quality

CONFORM

NOT CONFORM

Absence of marks, impacts or scratches

CONFORM

NOT CONFORM

REPORT SHEET – ITEM 05 – ANGLE

PART NUMBER 3

Dimensions	Theoretical		Measured
Flange	20	±0.5	
Flange	20	±0.5	
Angle	90°	±0.5°	
Length	148	±0.5	

Drilling	Theoretical		Measured
Edge distance	9	+1 / -0	
Edge distance	10	+1 / -0	
Number of holes	6 + 6		
Drilling quality	-		<input type="checkbox"/> OK <input type="checkbox"/> NOK
Deburring quality	-		<input type="checkbox"/> OK <input type="checkbox"/> NOK

Deburring quality

CONFORM

NOT CONFORM

Absence of marks, impacts or scratches

CONFORM

NOT CONFORM

Observations:

REPORT SHEET – ITEM 05 – ANGLE

PART NUMBER 4

Dimensions	Theoretical		Measured
Flange	20	±0.5	
Flange	20	±0.5	
Angle	90°	±0.5°	
Length	148	±0.5	

Drilling	Theoretical		Measured
Edge distance	9	+1 / -0	
Edge distance	10	+1 / -0	
Number of holes	6 + 6		
Drilling quality	-		<input type="checkbox"/> OK <input type="checkbox"/> NOK
Deburring quality	-		<input type="checkbox"/> OK <input type="checkbox"/> NOK

Deburring quality

CONFORM

NOT CONFORM

Absence of marks, impacts or scratches

CONFORM

NOT CONFORM

Observations:

Manufacturing parts #02 - open box - closing elements

Objectives: At the end of this exercise you shall be able to
 • manufacture complex parts.

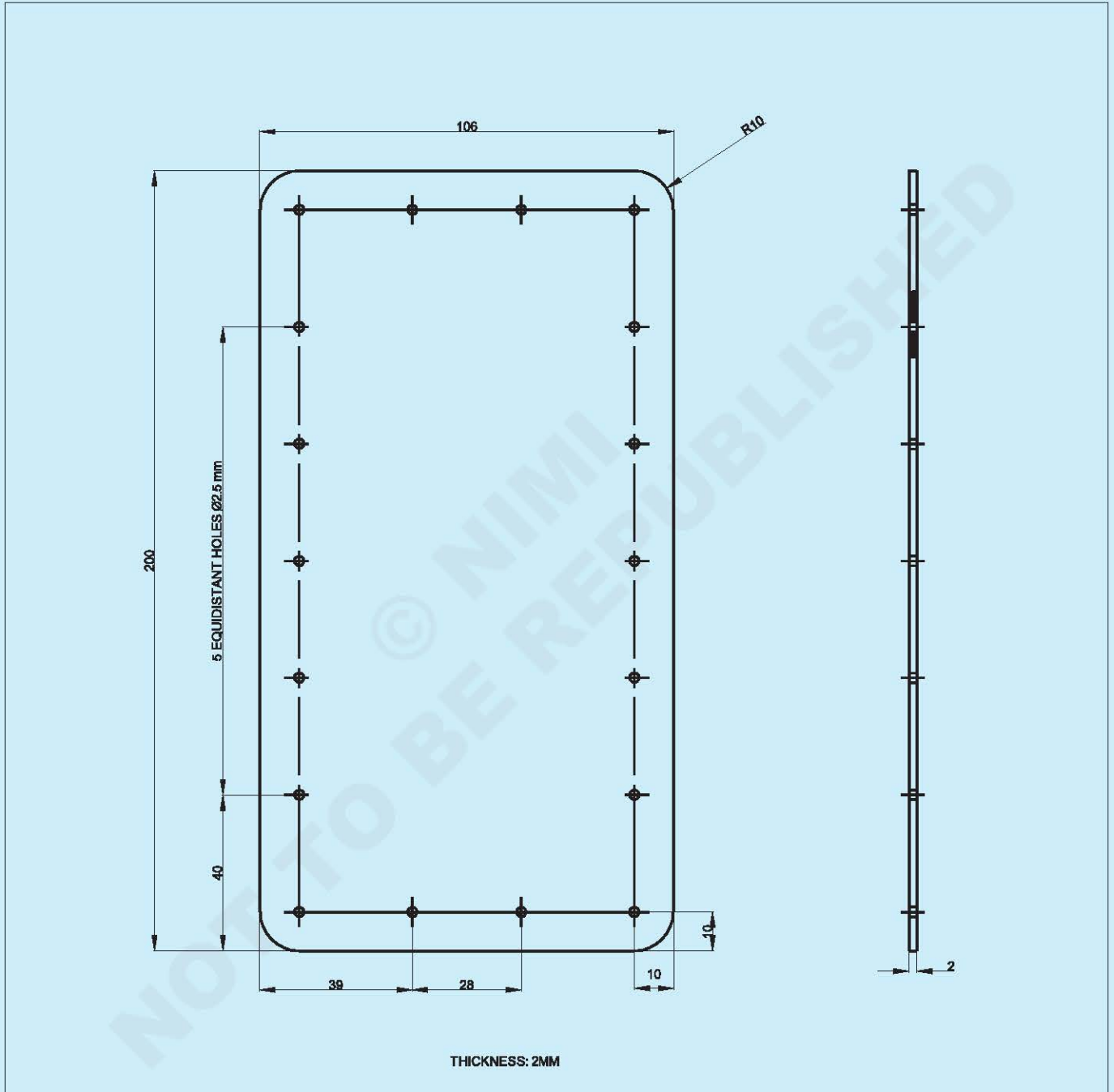

2	200X110 - 2MM	-	AW-2017	--	-	2.1.41
NO.OFF	STOCK SIZE	SEMI-PRODUCT	MATERIAL	PROJECT NO.	PART NO.	EX. NO.
SCALE: NTS	OPEN BOX - MANUFACTURING PARTS ITEM 06 - DOOR				DEVIATIONS	TIME: 4HRS
					CODE NO : AFN2141E1	

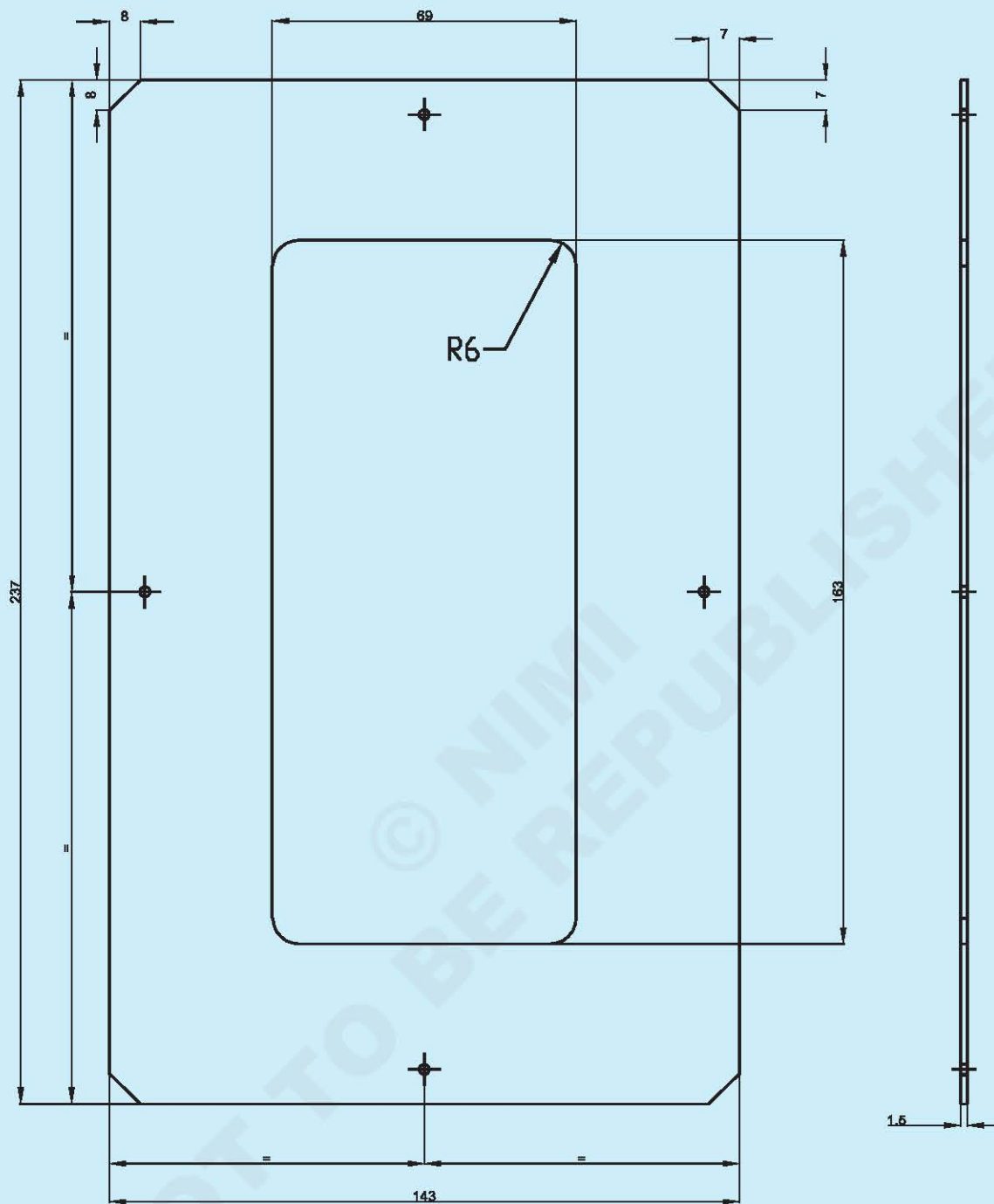

THICKNESS : 1.5MM

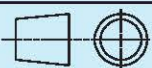
2	200X145 - 1.5MM	--	AW-2017	--	--	2.1.41
NO.OFF	STOCK SIZE	SEMI-PRODUCT	MATERIAL	PROJECT NO.	PART NO.	EX. NO.
SCALE: NTS	OPEN BOX - MANUFACTURING PARTS ITEM 07 - DOUBLER				DEVIATIONS	TIME: 4HRS
					CODE NO : AFN2141E2	

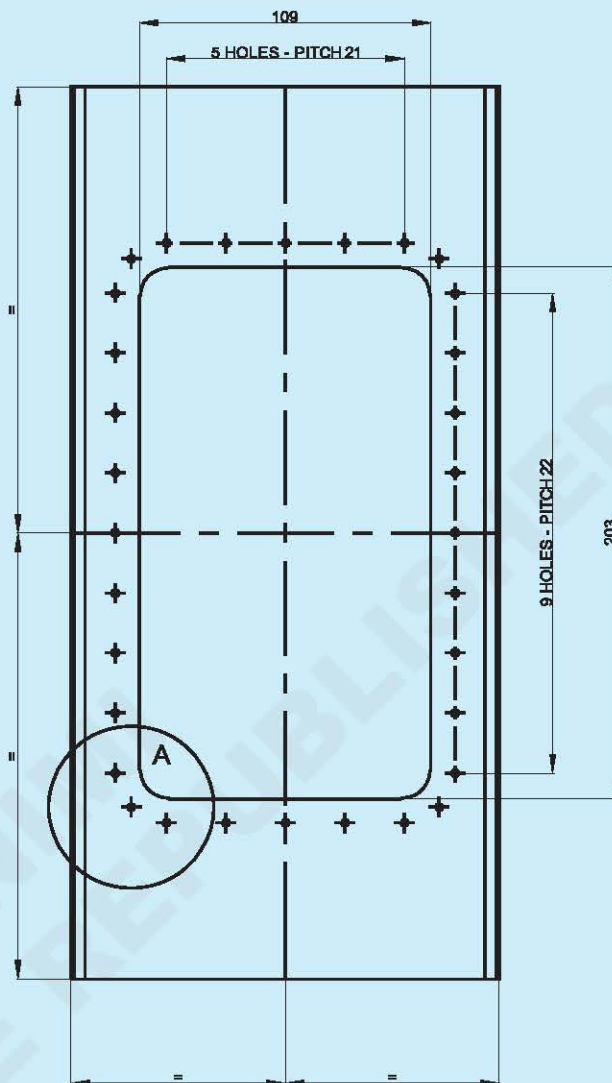
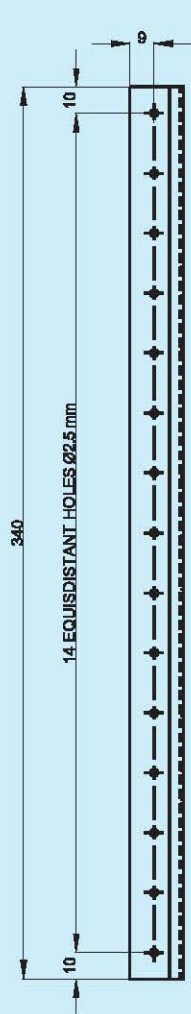

A
ROTATED

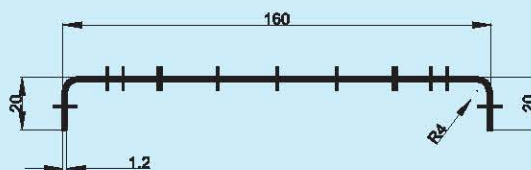
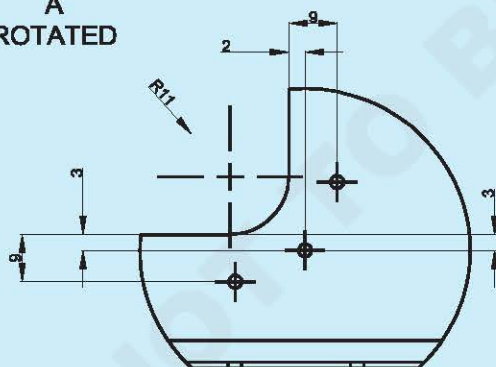

NOTE: Same holes in the other side

2	340X205 - 12MM	--	AW-2017	-	-	2.1.41
NO.OFF	STOCK SIZE	SEMI-PRODUCT	MATERIAL	PROJECT NO.	PART NO.	EX. NO.
SCALE: NTS	OPEN BOX - MANUFACTURING PARTS ITEM 07 - CLOSING FLANGE				DEVIATIONS	TIME: 12HRS
					CODE NO : AFN2141E3	

PROCEDURE

Manufacturing item 06

- Check dimensions and thickness.
- Mark and file external dimensions.
- Mark and file radii.
- Finish edges by draw filing.
- Deburr edges.
- Mark the holes positions.
- Punch the centre of the holes.

Drilling diameter 2.5

- Hold the workpiece and drill holes with hand drill.
- Deburr both sides.
- Check diameter and perpendicularity of each hole.

Manufacturing item 07

- Check dimensions and thickness.
- Mark and file external dimensions.
- Mark and file chamfers.
- Finish edges by draw filing.
- Deburr edges.
- Trace the cut-out.
- Drill the angles.
- Cut with a hacksaw and file.
- Finish edges by draw filing and deburr.
- Mark the holes positions.

- Punch the centre of the holes.

Drilling diameter 2.5

- Hold the workpiece and drill holes with hand drill.
- Deburr both sides.
- Check diameter and perpendicularity of each hole.

Manufacturing item 08

- Check dimensions and thickness.
- Calculate the developed length.
- Mark and file external dimensions calculated above.
- Finish edges by draw filing.
- Deburr edges.
- Bend the angles using brake.
- Check the angle and the dimensions. File if necessary.
- Trace the cut-out.
- Drill the angles.
- Cut with a hacksaw and file.
- Finish edges by draw filing and deburr.
- Mark the holes positions.
- Punch the centre of the holes.

Drilling diameter 2.5

- Hold the workpiece and drill holes with hand drill.
- Deburr both sides.
- Check diameter and perpendicularity of each hole.

REPORT SHEET - ITEM 06 - DOOR

Dimensions	Theoretical		Measured
External dimensions	106	±0.5	
	200	±0.5	
Radius	R10	±0.5	
	R10	±0.5	
	R10	±0.5	
	R10	±0.5	

Drilling	Theoretical		Measured
Edge distance	10	+1 / -0	
Number of holes	18		
Position	-		<input type="checkbox"/> OK <input type="checkbox"/> NOK
Drilling quality	-		<input type="checkbox"/> OK <input type="checkbox"/> NOK
Deburring quality	-		<input type="checkbox"/> OK <input type="checkbox"/> NOK

Deburring quality

CONFORM

NOT CONFORM

Absence of marks, impacts or scratches

CONFORM

NOT CONFORM

Observations:

REPORT SHEET – ITEM 07 – DOUBLER

Dimensions	Theoretical		Measured
External dimensions	143	±0.5	
	237	±0.5	
Chamfer	7x7	±0.5	
	7x7	±0.5	
	7x7	±0.5	
	7x7	±0.5	
Cut-out dimensions	69	±0.5	
	163	±0.5	
	R6	±0.5	

Drilling	Theoretical		Measured
Edge distance	8	+1 / -0	
Number of holes	4		
Position	-		<input type="checkbox"/> OK <input type="checkbox"/> NOK
Drilling quality	-		<input type="checkbox"/> OK <input type="checkbox"/> NOK
Deburring quality	-		<input type="checkbox"/> OK <input type="checkbox"/> NOK

Deburring quality

CONFORM

NOT CONFORM

Absence of marks, impacts or scratches

CONFORM

NOT CONFORM

Observations:

REPORT SHEET – ITEM 08 – CLOSING FLANGE

PART NUMBER 1

Dimensions	Theoretical		Measured
Flange	20	±0.5	
Flange	20	±0.5	
Angle	90°	±0.5°	
Length	340	±0.5	
Height	160	±0.5	
Cut-out dimensions	109	±0.5	
	203	±0.5	
	R11	±0.5	

Drilling	Theoretical		Measured
Edge distance	9	+1 / -0	
Number of holes	14 + 14		
Number of holes	32		
Position	-		<input type="checkbox"/> OK <input type="checkbox"/> NOK
Drilling quality	-		<input type="checkbox"/> OK <input type="checkbox"/> NOK
Deburring quality	-		<input type="checkbox"/> OK <input type="checkbox"/> NOK

Deburring quality

CONFORM

NOT CONFORM

Absence of marks, impacts or scratches

CONFORM

NOT CONFORM

Observations:

REPORT SHEET – ITEM 08 – CLOSING FLANGE

PART NUMBER 2

Dimensions	Theoretical		Measured
Flange	20	±0.5	
Flange	20	±0.5	
Angle	90°	±0.5°	
Length	340	±0.5	
Height	160	±0.5	
Cut-out dimensions	109	±0.5	
	203	±0.5	
	R11	±0.5	

Drilling	Theoretical		Measured
Edge distance	9	+1 / -0	
Number of holes	14 + 14		
Number of holes	32		
Position	-		<input type="checkbox"/> OK <input type="checkbox"/> NOK
Drilling quality	-		<input type="checkbox"/> OK <input type="checkbox"/> NOK
Deburring quality	-		<input type="checkbox"/> OK <input type="checkbox"/> NOK

Deburring quality

CONFORM

NOT CONFORM

Absence of marks, impacts or scratches

CONFORM

NOT CONFORM

Observations:

Open box assembly

Objectives: At the end of this exercise you shall be able to

- assemble and rivet open box.

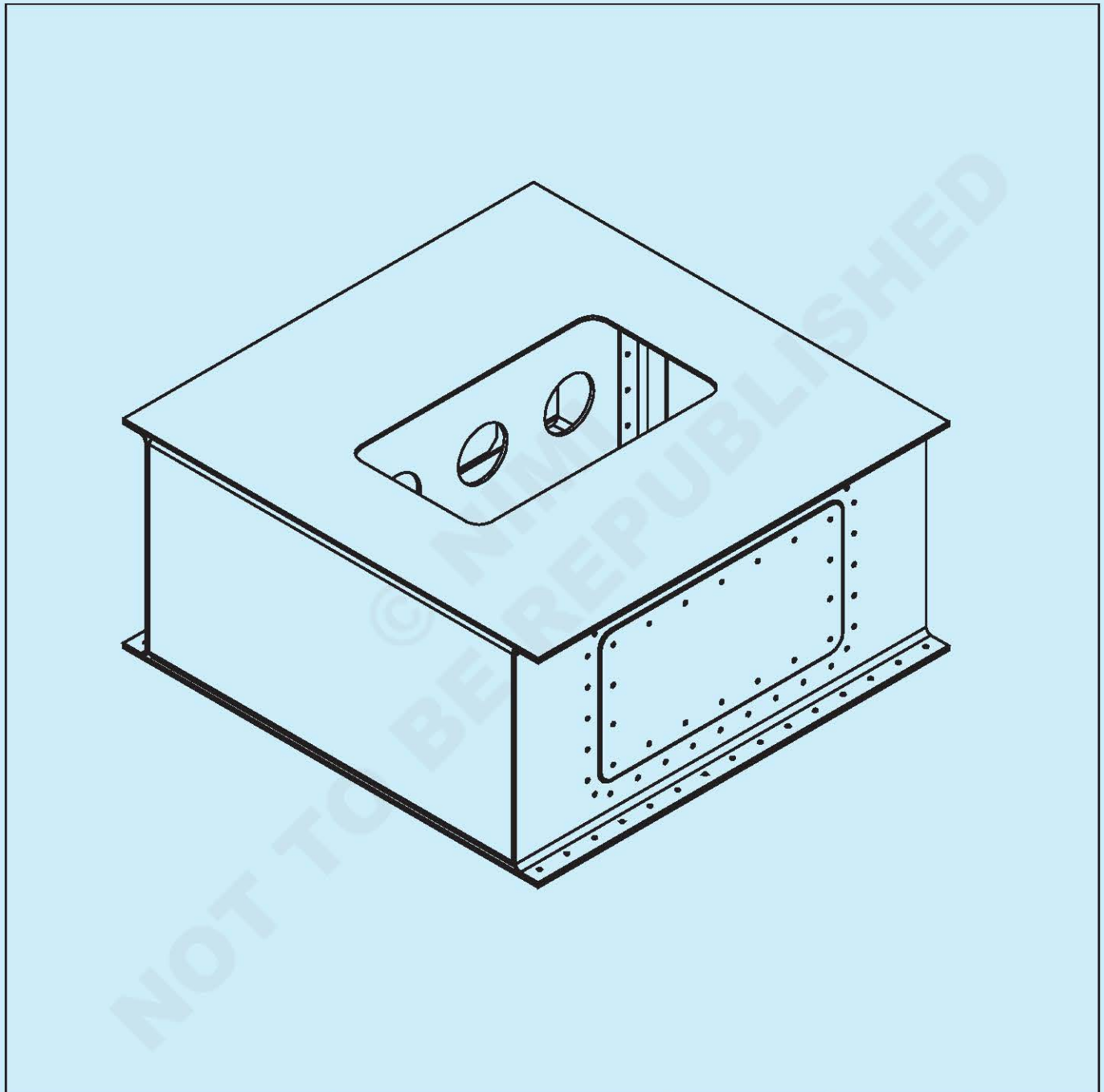

--	-	-	-	--	--	2.1.42
NO.OFF	STOCK SIZE	SEMI-PRODUCT	MATERIAL	PROJECT NO.	PART NO.	EX. NO.
SCALE: NTS	BOX ASSEMBLY OVERVIEW OF THE COMPLETE ASSEMBLY				DEVIATIONS	TIME: 10-HRS
					CODE NO : AFN2142E1	

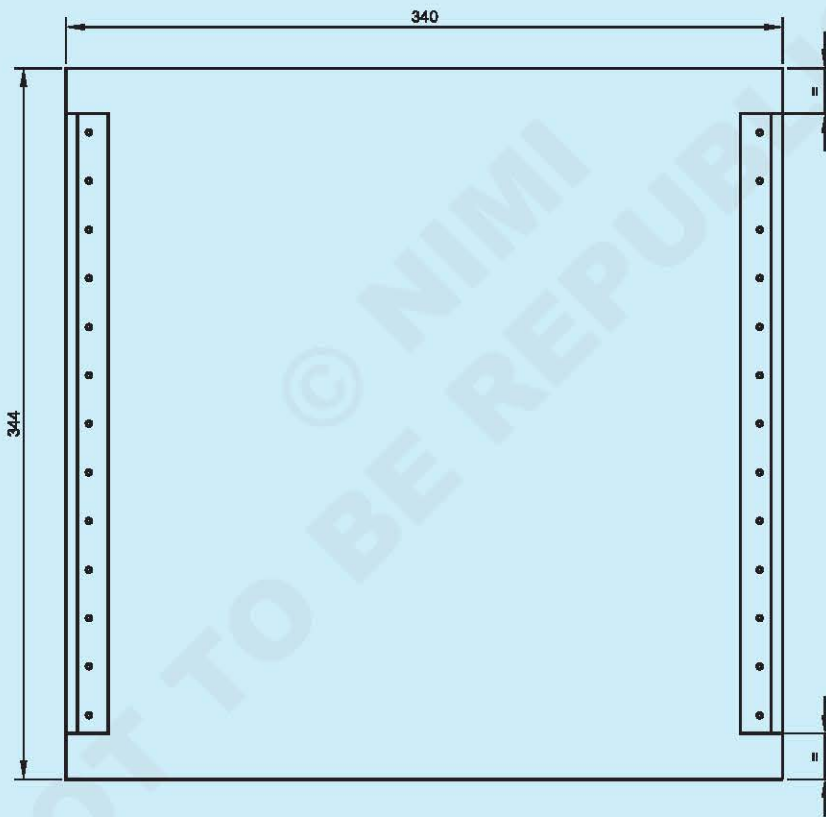
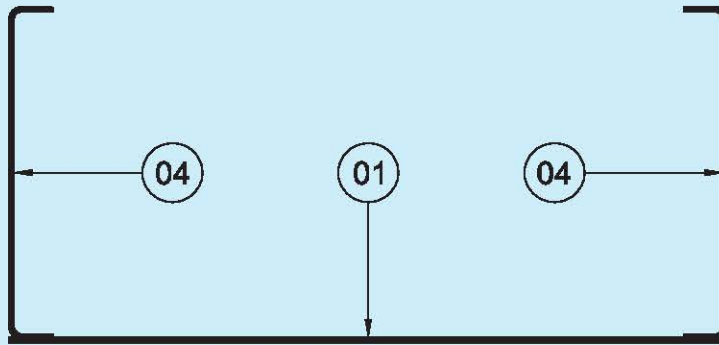

--	--	--	--	--	--	2.1.42
NO.OFF	STOCK SIZE	SEMI-PRODUCT	MATERIAL	PROJECT NO.	PART NO.	EX. NO.
SCALE: NTS	OPEN BOX ASSEMBLY PHASE 01				DEVIATIONS	TIME: 6HRS
					CODE NO : AFN2142E2	

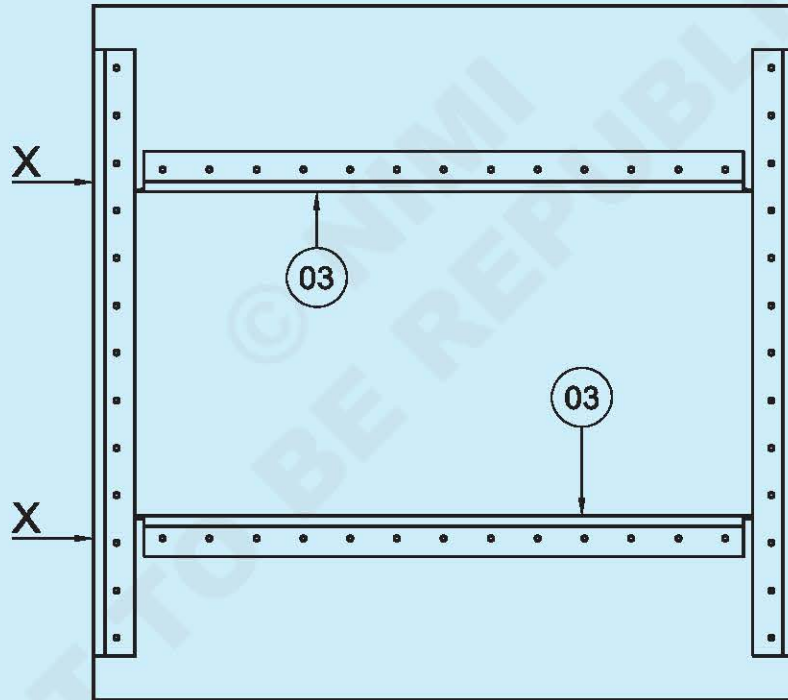
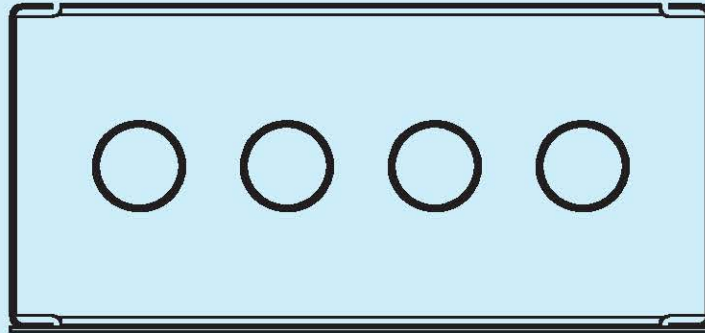

-	--	-	-	--	--	2.1.42
NO.OFF	STOCK SIZE	SEMI-PRODUCT	MATERIAL	PROJECT NO.	PART NO.	EX. NO.
SCALE: NTS	OPEN BOX ASSEMBLY PHASE 02				DEVIATIONS	TIME: 5HRS
					CODE NO : AFN2142E3	

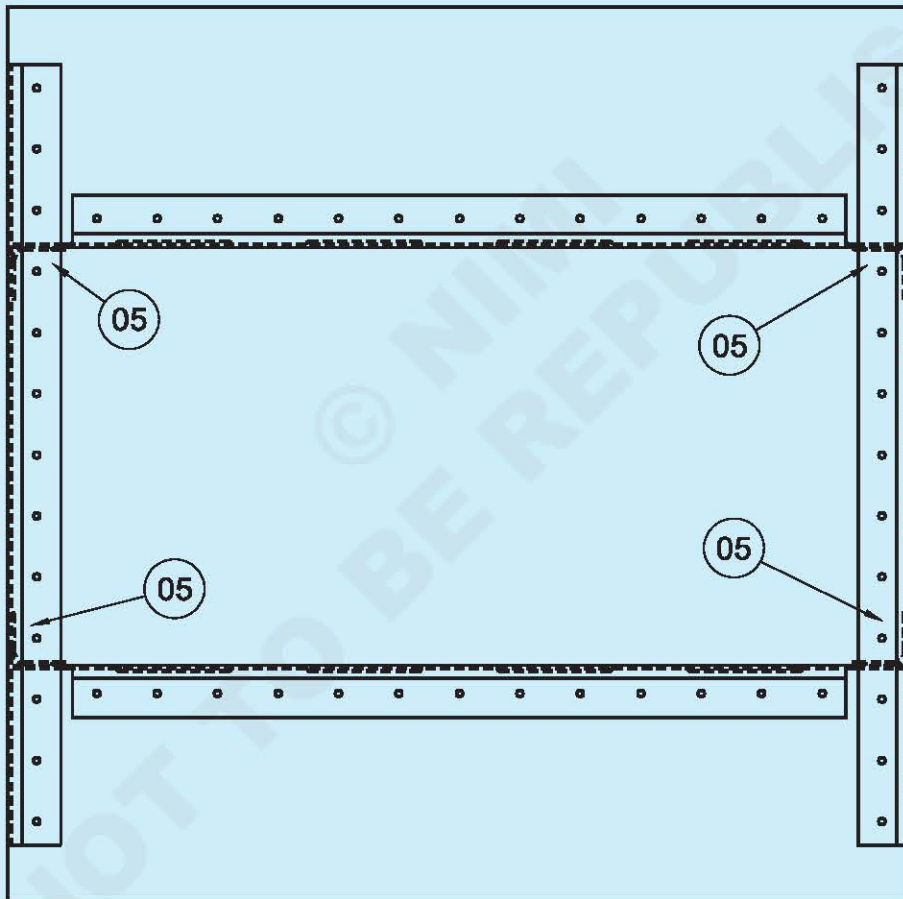
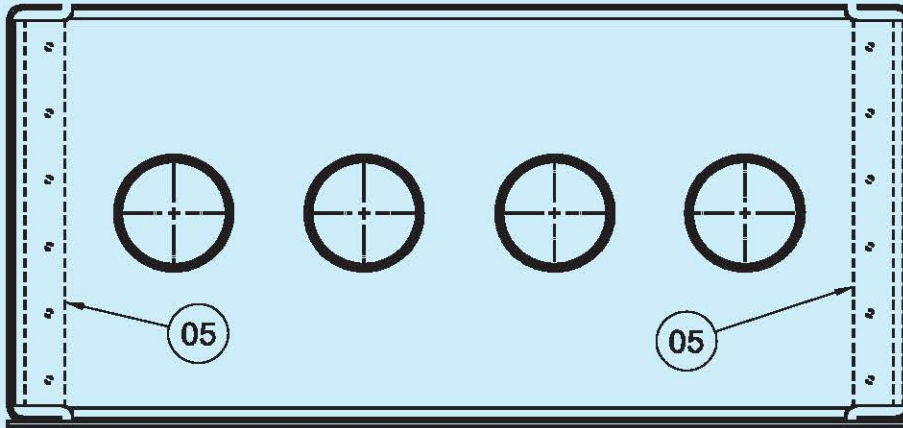

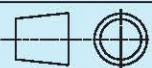
-	-	-	-	-	-	2.1.42
NO.OFF	STOCK SIZE	SEMI-PRODUCT	MATERIAL	PROJECT NO.	PART NO.	EX. NO.
SCALE: NTS	OPEN BOX ASSEMBLY PHASE 03				DEVIATIONS	TIME: 6HRS
					CODE NO : AFN2142E4	

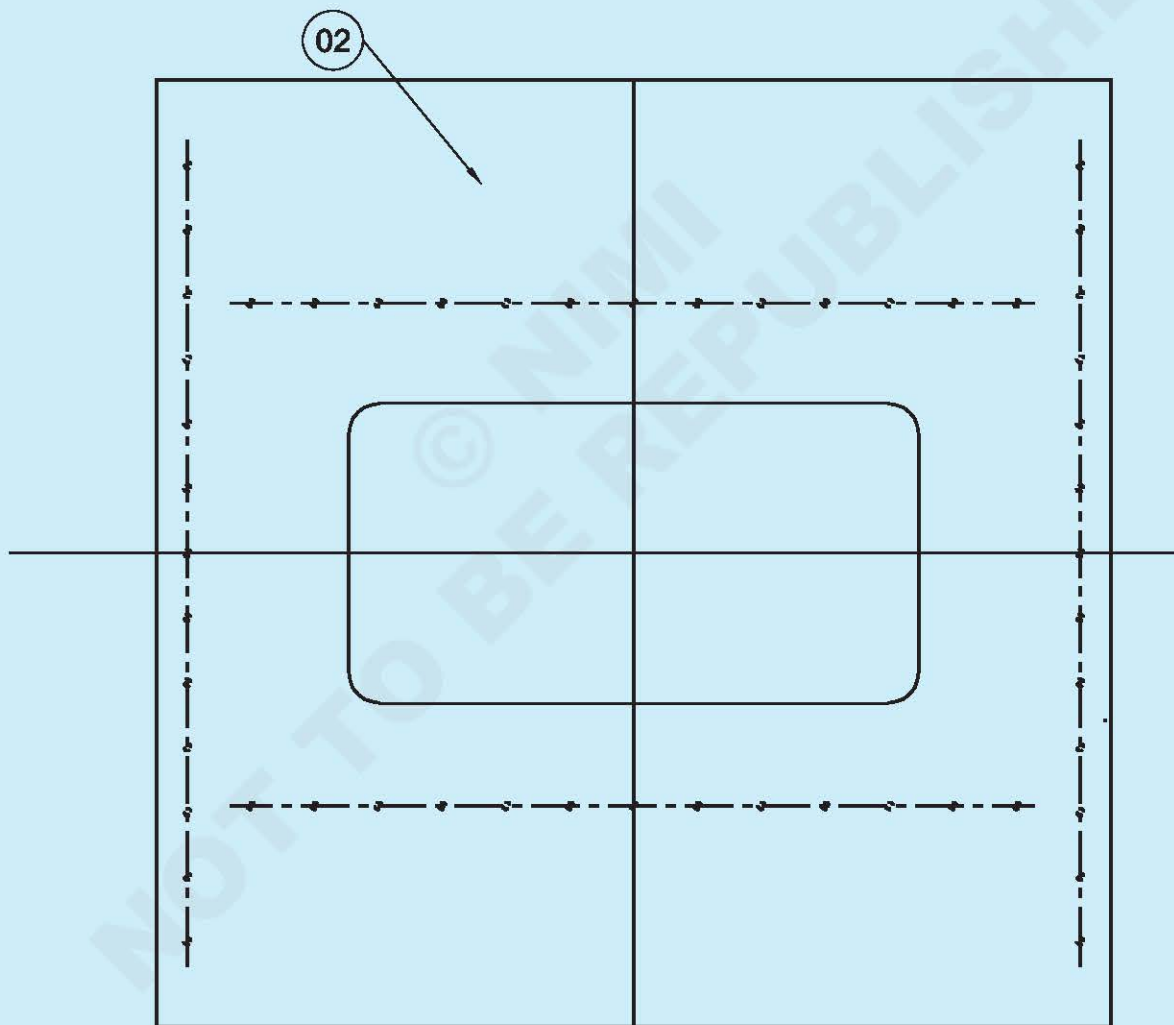
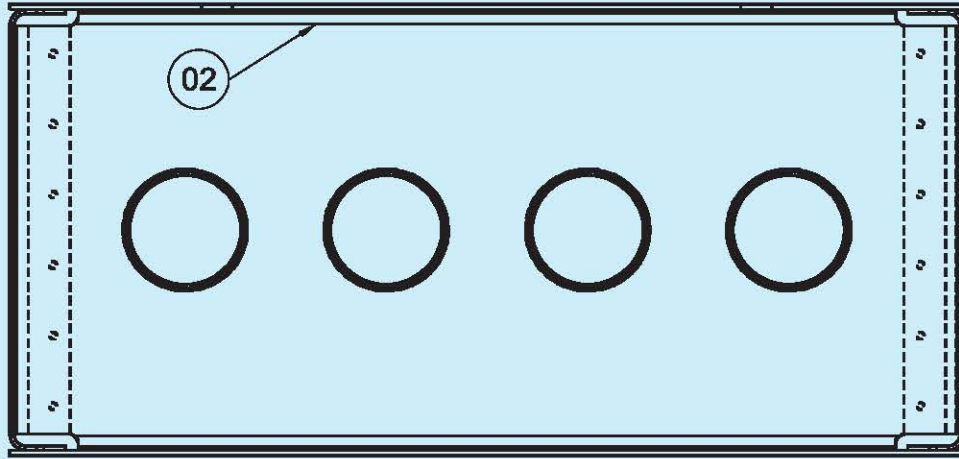

-	-	-	-	-	-	2.1.42
NO.OFF	STOCK SIZE	SEMI-PRODUCT	MATERIAL	PROJECT NO.	PART NO.	EX. NO.
SCALE: NTS	OPEN BOX ASSEMBLY PHASE 04				DEVIATIONS	TIME: 5HR6
					CODE NO : AFN2142E5	

PROCEDURE

PHASE 01

Assembly of the lower panel with the lateral flanges.

- Place the 2 items 04 (lateral flange) on item 01 (lower panel) according to the position.
- For easier positioning:
- Use a square to ensure perpendicularity.
- Use a V block to ensure flush.
- Use a depth calliper to ensure position.
- Lock with clamps.
- Counter-drill holes, clamping as you go (Diameter 2.5 mm).
- Check for accurate positioning.
- Counter-drill holes, clamping as you go (Diameter 3.3 mm).
- Disassemble and deburr.
- Countersink the lower panel.
- Reassemble by clamping. (Pin rate: 50%).

Rivets used

- Countersunk head rivet.
- Material 2117
- Diameter 3.2 mm (1/8")
- Rivet the unclamped holes with countersunk head rivet.
- Unclamp and finish the riveting.

PHASE 02

Assembly of the phase 01 sub-assembly with the internal flanges.

- Place the 2 items 03 (internal flange) on item 01 (lower panel) and between item 04 (lateral flange) according to the position.

Align the holes row with the hole marked by X on the drawing.

Ensure the gap between parts.

- For easier positioning:
- Use a square to ensure perpendicularity.
- Lock with clamps.
- Counter-drill holes, clamping as you go (Diameter 2.5 mm).
- Check for accurate positioning.
- Counter-drill holes, clamping as you go (Diameter 3.3 mm).
- Disassemble and deburr.
- Countersink the lower panel.
- Reassemble by clamping. (Pin rate: 50%).

Rivets used

- Countersunk head rivet.
- Material 2117
- Diameter 3.2 mm (1/8")
- Rivet the unclamped holes with countersunk head rivet.
- Unclamp and finish the riveting.

PHASE 03

Assembly of the phase 02 sub-assembly with the angles.

- Place the 4 items 05 (angle) on item 03 (internal flange) and item 04 (lateral flange) according to the position.

Ensure the gap between parts.

Ensure the perfect contact with parts.

The angle is centered.

- For easier positioning:
- Use a square to ensure perpendicularity.
- Lock with clamps.
- Counter-drill holes, clamping as you go (Diameter 2.5 mm) using angle drill.
- Check for accurate positioning.
- Counter-drill holes, clamping as you go (Diameter 3.3 mm).
- Disassemble and deburr.
- Reassemble by clamping. (Pin rate: 50%).

Rivets used:

- Universal head rivet.
- Material 2117
- Diameter 3.2 mm (1/8")
- Rivet the unclamped holes with universal head rivet.

The shop heads are inside the box.

- Unclamp and finish the riveting.

PHASE 04

Assembly of the phase 03 sub-assembly with the upper panel.

- Place the item 02 (upper panel) according to the position.
- Lock with clamps.
- Counter-drill holes, clamping as you go (Diameter 2.5 mm).
- Check for accurate positioning.
- Counter-drill holes, clamping as you go (Diameter 3.3 mm).

- Disassemble and deburr.
- Reassemble by clamping. (Pin rate: 50%).

- Diameter 3.2 mm (1/8")
- Rivet the unclamped holes with countersunk head rivet.

Rivets used:

- Countersunk head rivet.
- Material 2117

The shop heads are inside the box.

- Unclamp and finish the riveting.

Open box assembly – Lateral closing

Objectives: At the end of this exercise you shall be able to

- assemble and rivet to close box
- install nut plate.

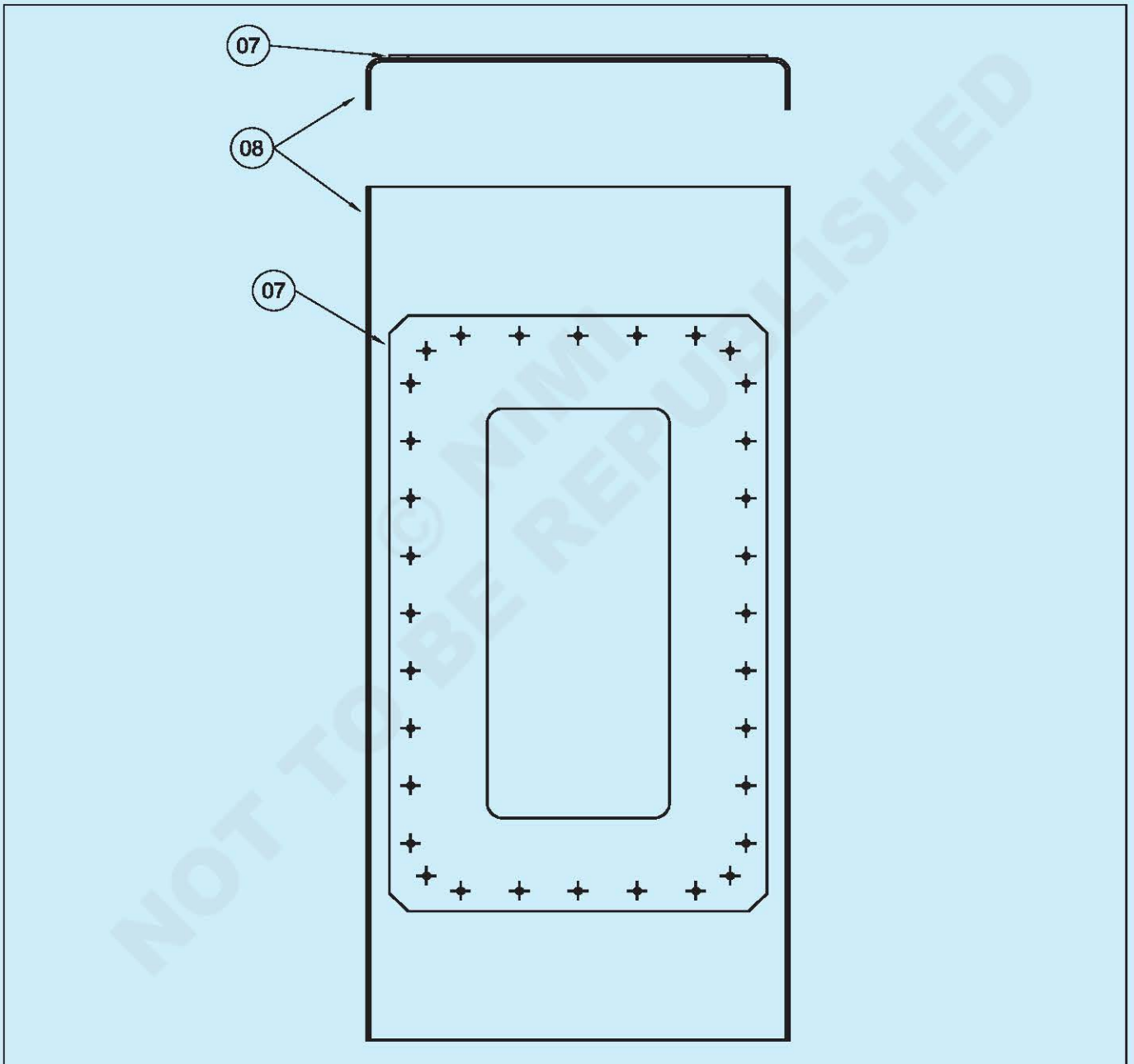

-	--	-	-	-	-	2.1.42
NO.OFF	STOCK SIZE	SEMI-PRODUCT	MATERIAL	PROJECT NO.	PART NO.	EX. NO.
SCALE: NTS	CLOSING BOX ASSEMBLY PHASE 05				DEVIATIONS	TIME: 5HRS
					CODE NO : AFN2142E6	

08

06

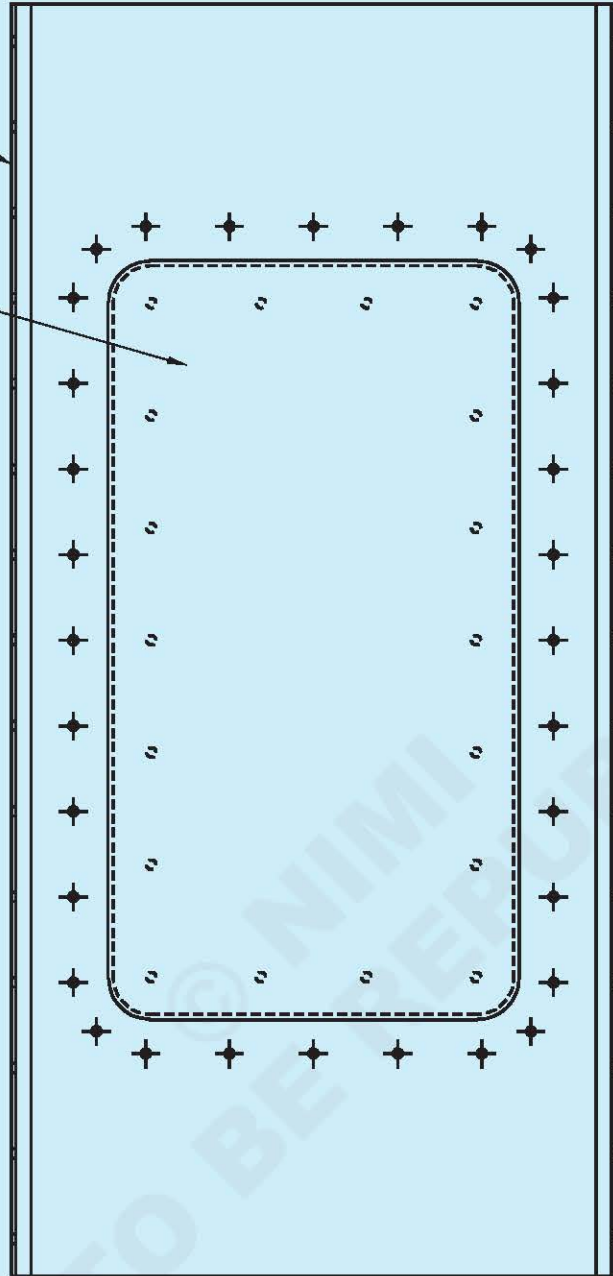

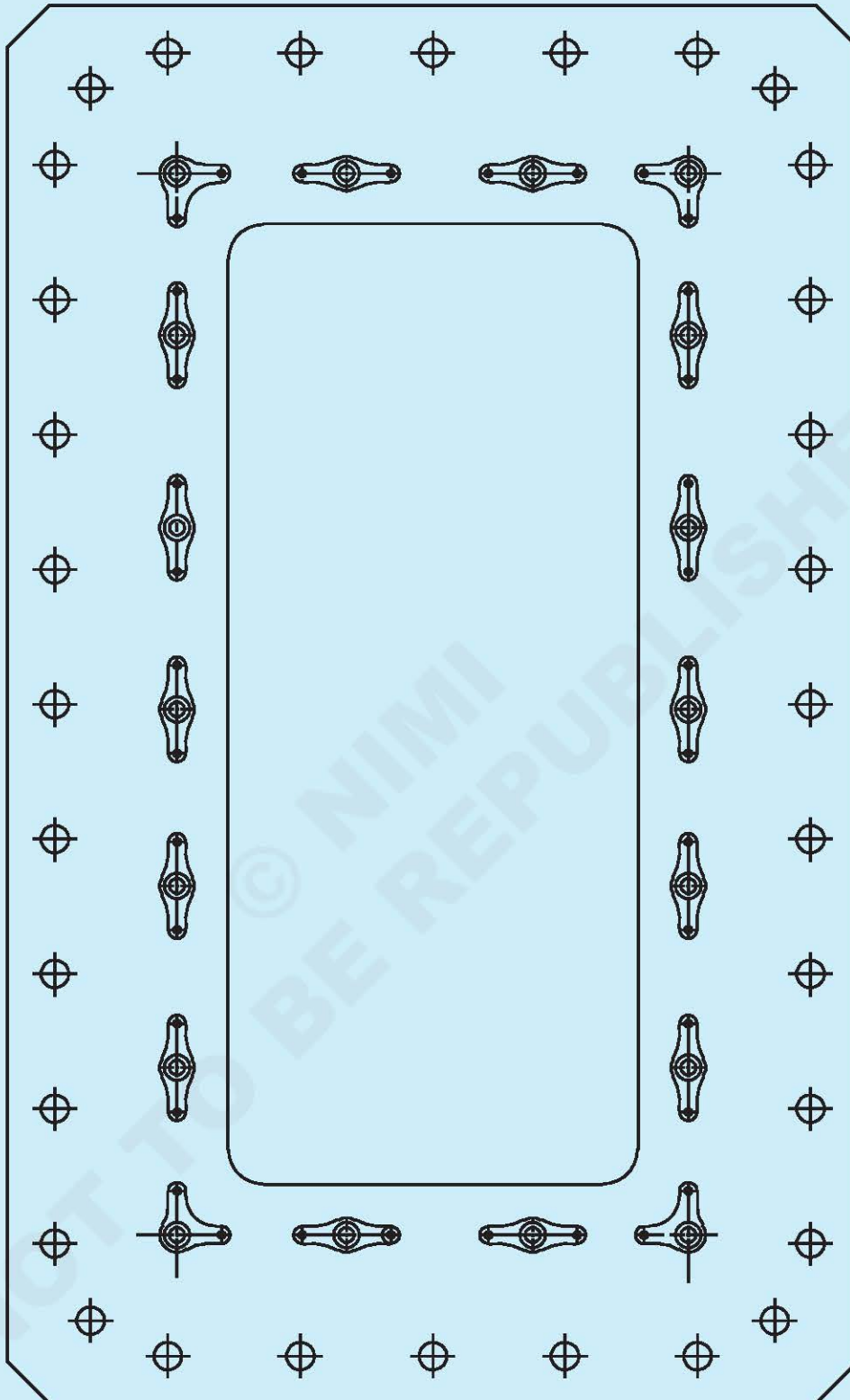

--	-	-	-	-	--	2.1.42
NO.OFF	STOCK SIZE	SEMI-PRODUCT	MATERIAL	PROJECT NO.	PART NO.	EX. NO.
SCALE: NTS		OPEN BOX ASSEMBLY PHASE 06			DEVIATIONS	TIME: 5HRS
					CODE NO : AFN2142E7	

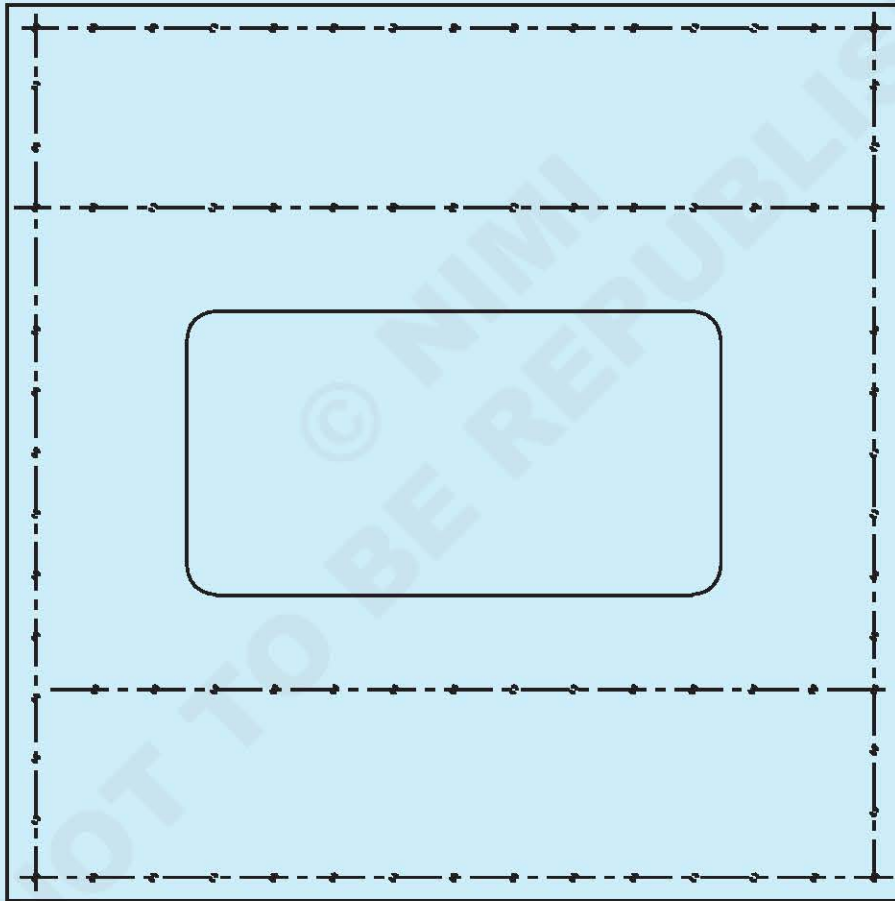
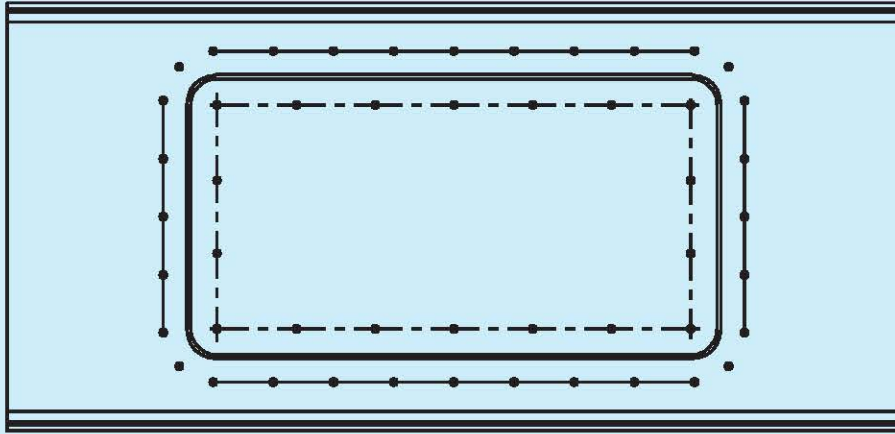

ANCHOR NUT RIVETING

-	-	-	-	-	-	2.1.42
NO.OFF	STOCK SIZE	SEMI-PRODUCT	MATERIAL	PROJECT NO.	PART NO.	EX. NO.
SCALE: NTS	CLOSING BOX ASSEMBLY PHASE 07				DEVIATIONS	TIME: 5HRS
					CODE NO : AFN2142E8	



-	-	-	-	-	-	2.1.42
NO.OFF	STOCK SIZE	SEMI-PRODUCT	MATERIAL	PROJECT NO.	PART NO.	EX. NO.
SCALE: NTS	OPEN BOX ASSEMBLY PHASE 08				DEVIATIONS	TIME: 6HRS
					CODE NO : AFN2142E8	

Job Sequence

PHASE 05

Assembly of the doubler 07 with the closing flange 08

Two sub-assemblies

- Place the item 07 (doubler) in the centre of the external side of the item 08 (closing flange).
- Lock with clamps.
- Counter-drill holes, clamping as you go (Diameter 2.5 mm).
- Check for accurate positioning.
- Counter-drill holes, clamping as you go (Diameter 3.3 mm).
- Disassemble and deburr.
- Reassemble by clamping. (Pin rate: 50%).

PHASE 06

Position of the door 06 with the sub-assembly phase 05

Two sub-assemblies

- Place the item 06 (door) in the cut-out of the item 08 (closing flange).
- Adjust a regular gap between edges.

To facilitate the operation, use shim.

- Lock with clamps.

- Counter-drill holes, clamping as you go (Diameter 2.5 mm).
- Check for accurate positioning.
- Counter-drill holes, clamping as you go (Diameter 3.3 mm).
- Counter-drill holes, clamping as you go (Diameter 4.1 mm).
- Identify the door orientation with pencil marks.
- Disassemble and deburr.
- Stock the door for further assembly.

PHASE 07

Nut plate equipment of the doubler 07

Two sub-assemblies

- Disassemble the doubler after marking position with a pencil.
- Drill 2.5 mm holes using nut plate jig on each hole (see drawing phase 07).
- Deburr holes.
- Countersink 2.5 mm hole.

The shop heads are in the external side.

- Counter-drill the centre hole following the table 1.

Table 1 – Recommended centre hole diameter

FIXED NUT		SCREW	
MIN	MAX	DIAMETER CODE	NOMINAL DIAMETER
3.0	3.1	04	2.85 mm
3.7	3.8	06	3.50 mm
4.3	4.4	08	4.17 mm
5.0	5.1	3	4.83 mm
6.5	6.6	4	6.35 mm
8.1	8.2	5	7.94 mm
9.7	9.8	6	9.52 mm
12.9	13.0	8	12.7 mm

Rivets used

- Countersunk head rivet.
- Material 2117
- Diameter 2.4 mm (3/32)
- Rivet the nut plates with countersunk head rivet.
- Reassemble the doubler in the closing flange by clamping. (Pin rate: 50%).

Rivets used

- Universal head rivet.
- Material 2117
- Diameter 3.2 mm (1/8")
- Rivet the unclamped holes with countersunk head rivet.

The shop heads are in the doubler side.

- Unclamp and finish the riveting.

PHASE 08

Assembly of the closing flange sub-assembly with the open box

Two sub-assemblies

- Place the closing flange in position.
- Check the flushness.
- Lock with clamps.

- Counter-drill holes using angle drill, clamping as you go (Diameter 2.5 mm).
- Check for accurate positioning.
- Counter-drill holes, clamping as you go (Diameter 3.3 mm).
- Countersink the lower panel for countersunk head rivet.
- Disassemble and deburr.

Rivets used – Lower part

- Countersunk head rivet.
- Material 2117
- Diameter 3.2 mm (1/8")

Rivets used – Upper part

- Universal head rivet.
- Material 2117
- Diameter 3.2 mm (1/8")
- Rivet the unclamped holes with countersunk head rivet.

The shop heads are in the closing flange side.

- Unclamp and finish the riveting.
- Position the doors and screw with hexagonal head screws.
- Check the gap.