

ELECTRICIAN

NSQF LEVEL - 5

1st Year (Volume II of II)

TRADE PRACTICAL

SECTOR : Power



Directorate General of Training

DIRECTORATE GENERAL OF TRAINING
MINISTRY OF SKILL DEVELOPMENT & ENTREPRENEURSHIP
GOVERNMENT OF INDIA



**NATIONAL INSTRUCTIONAL
MEDIA INSTITUTE, CHENNAI**

Post Box No. 3142, CTI Campus, Guindy, Chennai - 600 032

Sector : Power
Duration : 1 Year
Trade : Electrician - 1st Year (Volume II of II) Trade Practical NSQF (Level - 5)

Developed & Published by



National Instructional Media Institute

Post Box No.3142
Guindy, Chennai - 600032
INDIA
Email: chennai-nimi@nic.in
Website: www.nimi.gov.in

Printed by

National Instructional Media Institute

Chennai - 600 032

First Edition : October 2018 Copies : 1,000
First Reprint : March 2020 Copies : 2,000

Rs.180/-

FOREWORD

The Government of India has set an ambitious target of imparting skills to 30 crores people, one out of every four Indians, by 2020 to help them secure jobs as part of the National Skills Development Policy. Industrial Training Institutes (ITIs) play a vital role in this process especially in terms of providing skilled manpower. Keeping this in mind, and for providing the current industry relevant skill training to Trainees, ITI syllabus has been recently updated with the help of Mentor Councils comprising various stakeholder's viz. Industries, Entrepreneurs, Academicians and representatives from ITIs.

The National Instructional Media Institute (NIMI), Chennai, an autonomous body under Ministry of Skill Development & Entrepreneurship is entrusted with developing producing and disseminating Instructional Media Packages (IMPs) required for ITIs and other related institutions.

The institute has now come up with instructional material to suit the revised curriculum for **Electrician - 1st Year (Volume - II of II) Trade Practical NSQF Level - 5 in Power sector** under annual pattern. The NSQF Level - 5 Trade Theory will help the trainees to get an international equivalency standard where their skill proficiency and competency will be duly recognized across the globe and this will also increase the scope of recognition of prior learning. NSQF Level - 5 trainees will also get the opportunities to promote life long learning and skill development. I have no doubt that with NSQF Level - 5 the trainers and trainees of ITIs, and all stakeholders will derive maximum benefits from these IMPs and that NIMI's effort will go a long way in improving the quality of Vocational training in the country.

The Executive Director & Staff of NIMI and members of Media Development Committee deserve appreciation for their contribution in bringing out this publication.

Jai Hind

Director General
Directorate General of Training
Ministry of Skill Development & Entrepreneurship,
Government of India.

New Delhi - 110 001

PREFACE

The National Instructional Media Institute (NIMI) was established in 1986 at Chennai by then Directorate General of Employment and Training (D.G.E & T), Ministry of Labour and Employment, (now under Ministry of Skill Development and Entrepreneurship), MSME Government of India, with technical assistance from the Govt. of the Federal Republic of Germany. The prime objective of this institute is to develop and provide instructional materials for various trades as per the prescribed syllabi (NSQF) under the Craftsman and Apprenticeship Training Schemes.

The instructional materials are created keeping in mind, the main objective of Vocational Training under NCVT/NAC in India, which is to help an individual to master skills to do a job. The instructional materials are generated in the form of Instructional Media Packages (IMPs). An IMP consists of Theory book, Practical book, Test and Assignment book, Instructor Guide, Audio Visual Aid (Wall charts and Transparencies) and other support materials.

The trade practical book consists of series of exercises to be completed by the trainees in the workshop. These exercises are designed to ensure that all the skills in the prescribed syllabus are covered. The trade theory book provides related theoretical knowledge required to enable the trainee to do a job. The test and assignments will enable the instructor to give assignments for the evaluation of the performance of a trainee. The wall charts and transparencies are unique, as they not only help the instructor to effectively present a topic but also help him to assess the trainee's understanding. The instructor guide enables the instructor to plan his schedule of instruction, plan the raw material requirements, day to day lessons and demonstrations.

In order to perform the skills in a productive manner instructional videos are embedded in QR code of the exercise in this instructional material so as to integrate the skill learning with the procedural practical steps given in the exercise. The instructional videos will improve the quality of standard on practical training and will motivate the trainees to focus and perform the skill seamlessly.

IMPs also deals with the complex skills required to be developed for effective team work. Necessary care has also been taken to include important skill areas of allied trades as prescribed in the syllabus.

The availability of a complete Instructional Media Package in an institute helps both the trainer and management to impart effective training.

The IMPs are the outcome of collective efforts of the staff members of NIMI and the members of the Media Development Committees specially drawn from Public and Private sector industries, various training institutes under the Directorate General of Training (DGT), Government and Private ITIs.

NIMI would like to take this opportunity to convey sincere thanks to the Directors of Employment & Training of various State Governments, Training Departments of Industries both in the Public and Private sectors, Officers of DGT and DGT field institutes, proof readers, individual media developers and coordinators, but for whose active support NIMI would not have been able to bring out this materials.

Chennai - 600 032

**R. P. DHINGRA
EXECUTIVE DIRECTOR**

ACKNOWLEDGEMENT

National Instructional Media Institute (NIMI) sincerely acknowledges with thanks for the co-operation and contribution extended by the following Media Developers and their sponsoring organisations to bring out this Instructional Material (**Trade Practical**) for the trade of **Electrician NSQF LEVEL - 5** under **Power** Sector for ITIs.

MEDIA DEVELOPMENT COMMITTEE MEMBERS

Shri D.S. Varadarajulu	–	DD/Principal (Retd.), Govt. ITI, Ambattur, Chennai - 98
Shri G. Ethirajulu	–	Principal (Retd.), Govt. ITI, Guindy Chennai - 32
Shri P. Natarajan	–	Assistant Training Officer Govt. ITI, Anaikatti, Coimbatore (Dist)
Shri K. Mohandass	–	Assistant Training Officer Govt. ITI, North Chennai Chennai - 21.

NIMI CO-ORDINATORS

Shri K. Srinivasa Rao	-	Joint Director NIMI, Chennai - 32.
Shri Subhankar Bhowmik	-	Assistant Manager NIMI, Chennai - 32.

NIMI records its appreciation for the Data Entry, CAD, DTP operators for their excellent and devoted services in the process of development of this Instructional Material.

NIMI also acknowledges with thanks the invaluable efforts rendered by all other NIMI staff who have contributed towards the development of this Instructional Material.

NIMI is also grateful to everyone who has directly or indirectly helped in developing this Instructional Material.

INTRODUCTION

This manual for trade practical is intended for use in the ITI workshop. It consists of a series of practical exercises that are to be completed by the trainees during the course of **Electrician trade under Power Sector. It is National Skills Qualifications Framework (NSQF) - Level 5**, supplemented and supported by instructions/information to assist the trainees in performing the exercise. The exercises are designed to ensure that all the skills prescribed in the syllabus are covered including the allied trades. The Practical is divided into seven modules. The allocation of time for the various modules is given below:

Module 1 - Cells and Batteries	5 Exercises	50 Hrs
Module 2 - Basic Wiring Practice	7 Exercises	100 Hrs
Module 3 - Wiring Installation and Earthing	9 Exercises	100 Hrs
Module 4 - Illumination	6 Exercises	50 Hrs
Module 5 - Measuring Instrument	8 Exercises	75 Hrs
Module 6 - Domestic Appliances	6 Exercises	75 Hrs
Module 7 - Transformer	9 Exercises	75 Hrs
Total	50 Exercises	525 Hrs

The syllabus and the content in the modules are interlinked. As the number of workstations available in the electrical section is limited by the machinery and equipment, it is necessary to interpolate the exercises in the modules to form a proper teaching and learning sequence. The sequence of instruction is given in the schedule of instruction which is incorporated in the Instructor's Guide. With 25 practical hours a week of 5 working days 100 hours of practical per month is available.

Contents of Trade Practical

The procedure for working through the 50 exercises with the specific objectives as the learning outcomes at the end of each exercise is given in this book.

The skill objectives and tools/instruments, equipment/machines and materials required to perform the exercise are given in the beginning of each exercise. Skill training in the shop floor is planned through a series of practical exercises/experiments to support the related theory to make the trainees get hands on training in the Electrician trade along with the relevant cognitive skills appropriate for the level. A minimum number of projects have been included to make the training more effective and develop attitude to work in a team. Pictorial, schematic, wiring and circuit diagrams have been included in the exercises, wherever necessary, to assist the trainees broaden their views. The symbols used in the diagrams comply with the Bureau of Indian Standards (BIS) specifications.

Illustrations in this manual, help trainees visual perspective of the ideas and concepts. The procedures to be followed for completing the exercises is also given. Different forms of intermediate test questions have been included in the exercises, to enhance the trainee to trainee and trainee to instructor interactions.

Skill Information

Skill areas which are repetitive in nature are given as separate skill information sheets. Skills which are to be developed in specific areas are included in the exercises itself. Some subexercises are developed to fulfill the sequence of exercises in keeping with the syllabus.

This manual on trade practical forms part of the Written Instructional Material (WIM). Which includes manual on trade theory and assignment/test.

CONTENTS

Exercise No.	Title of the Exercise	Learning Outcome	Page No.
Module 1 : Cells and Batteries			
2.1.65	Use of various types of cell	1	1
2.1.66	Practice on grouping of cells for specified voltage and current under different conditions and care		3
2.1.67	Prepare and practice on battery charging and details of charging circuit		6
2.1.68	Practice on routine, care / maintenance and testing of batteries		9
2.1.69	Determine the number of solar cells in series / Parallel for given power requirement		11
Module 2 : Basic Wiring Practice			
2.2.70	Identify various conduits and different electrical accessories	2	13
2.2.71	Practice cutting, threading of different sizes of conduits and laying installations		21
2.2.72	Prepare test boards/extension boards and mount accessories like lamp holders, various switches, sockets, fuses, relays, MCB, ELCB, MCCB Etc.		27
2.2.73	Draw layouts and practice in PVC casing - capping, conduit wiring with minimum to more number of points of minimum 15 metre length		29
2.2.74	Wire up PVC Conduit wiring to control one lamp from two different places		31
2.2.75	Wire up PVC conduit wiring to control one lamp from 3 different places		33
2.2.76	Wire up PVC Conduit wiring and practice control of sockets and lamps in different combinations using switching concepts		36
Module 3 : Wiring Installation and Earthing			
2.3.77	Wire up the consumer's main board with I.C.D.P. switch and distribution fuse box	3	39
2.3.78	Prepare and mount the energy meter board		41
2.3.79	Estimate the cost/bill of material for wiring of hostel/residential building and workshop		45
2.3.80	Practice wiring of hostel and residential building as per IE rules		51
2.3.81	Practice wiring of Institute and workshop as per IE rules		53
2.3.82	Practice testing /fault detection of domestic and industrial wiring installation and repair		55
2.3.83	Prepare pipe earthing and measure earth resistance by earth tester/megger		57
2.3.84	Prepare plate earthing and measure earth resistance by earth tester/megger		60
2.3.85	Test earth leakage by ELCB and relay	63	
Module 4 : Illumination			
2.4.86	Install light fitting with reflectors for direct & indirect lightings	4	65
2.4.87	Group different wattage lamps in series for specified voltage		66
2.4.88	Practice installation of various lamps eg. fluorescent tube, HP mercury vapour, LP mercury vapour, HP Sodium vapour, LP Sodium vapour, Metal halide etc.		69
2.4.89	Prepare decorative lamp circuits using drum switches		74
2.4.90	Prepare a decorative lamp circuit to produce rotating light effect/ running light effect		75
2.4.91	Install light fitting for show case lighting		77

Exercise No.	Title of the Exercise	Learning Outcome	Page No.
Module 5 : Measuring Instrument			
2.5.92	Practice on various analog and digital measuring instruments		78
2.5.93	Practice on measuring instrument in single and three phase circuit eg. multimeter, wattmeter, energy meter, phase sequence and frequency meter etc.		82
2.5.94	Measure the power in 3-phase circuit using two wattmeter methods		85
2.5.95	Measure power factor in three phase circuit by using power factor meter and verify the same with Voltmeter, Ammeter, Wattmeter readings.		87
2.5.96	Measure electrical parameters using tong tester in three phase circuit	5,6	90
2.5.97	Practice for range extension and calibration of various measuring instruments		93
2.5.98	Determine errors in resistance measurement by voltage drop method		99
2.5.99	Test single phase energy meter for its errors		101
Module 6 : Domestic Appliances			
2.6.100	Dismantle and assemble electrical parts of various electrical appliance e.g cooking range, geyser, washing machine and pump set		104
2.6.101	Service and repair of Bell / Buzzer		107
2.6.102	Service and repair of electric iron, electric kettle, cooking range and geyser	7	109
2.6.103	Service and repair of Induction heater and oven		115
2.6.104	Service and repair of mixer and grinder		118
2.6.105	Service and repair of Washing machine		125
Module 7 : Transformer			
2.7.106	Verify terminals identify components and calculate transformation ratio of single phase transformer		129
2.7.107	Perform open circuit and short circuit test to determine the efficiency of single phase transformer		131
2.7.108	Determine Voltage regulation of single phase transformer at different loads and power factors	8	134
2.7.109	Perform series and parallel operation of two single phase transformers		136
2.7.110	Verify the terminals and accessories of three phase transformer HT and LT side		138
2.7.111	Perform 3 phase operation (i) delta - delta (ii) delta - star (iii) star-star (iv) star - delta by use of three single phase transformers.		141
2.7.112	Test and replace transformer oil		144
2.7.113	Practice on winding of small transformer		146
2.7.114	Practice of general maintenance of transformer		153

LEARNING / OUTCOME

On completion of this book you shall be able to

Sl.No.	Learning/Outcome	Refer Ex:No
1	Install, test and maintain Batteries and Solar Cell	2.1.65 to 69
2	Estimate, Assemble, Install and Test Wiring System	2.2.70 to 76
3	Plan and prepare Earthing Installation	2.3.77 to 85
4	Plan and execute Electrical Illumination System and Test	2.4.86 to 91
5	Select and perform measurements using analog / digital instrument and its calibration	2.5.92 to 99
6	Perform testing, verify errors and calibrate instruments	2.5.92 to 99
7	Plan and carryout installation, fault defection and repairing of Domestic Appliances	2.6.100 to 105
8	Execute testing, evaluate performance and maintenance of Transformer.	2.7.106to 114

SYLLABUS

Duration: Six Months

Week No.	Ref. Learning Outcome	Professional Skills(Trade Practical) with Indicative hours	Professional Knowledge (Trade Theory)
27 - 37	<ul style="list-style-type: none"> • Install, test and maintenance of batteries and solar cell • Apply safe working practices 	<p>65. Use of various types of cells. (08 Hrs)</p> <p>66. Practice on grouping of cells for specified voltage and current under different conditions and care. (12 Hrs)</p> <p>67. Prepare and practice on battery charging and details of charging circuit. (12 Hrs)</p> <p>68. Practice on routine, care/ maintenance and testing of batteries. (08 Hrs)</p> <p>69. Determine the number of solar cells in series / parallel for given power</p>	<p>Chemical effect of electric current and Laws of electrolysis. Explanation of Anodes and cathodes.</p> <p>Types of cells, advantages / disadvantages and their applications.</p> <p>Lead acid cell; Principle of operation and components.</p> <p>Types of battery charging, Safety precautions, test equipment and maintenance.</p> <p>Basic principles of Electroplating and cathodic protection</p> <p>Grouping of cells for specified voltage and current.</p> <p>Principle and operation of solar cell</p>
29 - 30	<ul style="list-style-type: none"> • Estimate, Assemble, install and test wiring system 	<p>70. Identify various conduits and different electrical accessories. (8 Hrs)</p> <p>71. Practice cutting, threading of different sizes & laying Installations. (17 Hrs)</p> <p>72. Prepare test boards / extension boards and mount accessories like lamp holders, various switches, sockets, fuses, relays, MCB, ELCB, MCCB etc. (25 Hrs)</p>	<p>I.E. rules on electrical wiring. Types of domestic and industrial wirings.</p> <p>Study of wiring accessories e.g. switches, fuses, relays, MCB, ELCB, MCCB etc.</p> <p>Grading of cables and current ratings.</p> <p>Principle of laying out of domestic wiring.</p> <p>Voltage drop concept</p>
31 - 32	<ul style="list-style-type: none"> • Estimate, Assemble, install and test wiring system 	<p>73. Draw layouts and practice in PVC Casing-capping, Conduit wiring with minimum to more number of points of minimum 15 mtr length. (15 Hrs)</p> <p>74. Wire up PVC conduit wiring to control one lamp from two different places. (10 Hrs)</p> <p>75. Wire up PVC conduit wiring to control one lamp from three different places. (10 Hrs)</p>	<p>PVC conduit and Casing-capping wiring system.</p> <p>Different types of wiring - Power, control, Communication and entertainment wiring.</p> <p>Wiring circuits planning, permissible load in sub-circuit and main circuit</p>

		76. Wire up PVC conduit wiring and practice control of sockets and lamps in different combinations using switching concepts. (15 Hrs)	
33 - 35	<ul style="list-style-type: none"> Estimate, Assemble, install and test wiring system 	77. Wire up the consumers main board with ICDP switch and distribution fuse box. (10 Hrs) 78. Prepare and mount the energy meter board. (10 Hrs) 79. Estimate the cost/bill of material for wiring of hostel/ residential building and workshop. (10 Hrs) 80. Practice wiring of hostel and residential building as per IE rules. (15 Hrs) 81. Practice wiring of institute and workshop as per IE rules. (15 Hrs) 82. Practice testing / fault detection of domestic and industrial wiring installation and repair. (15 Hrs)	Estimation of load, cable size, bill of material and cost. Inspection and testing of wiring installations. Special wiring circuit e.g. godown, tunnel and workshop etc
36	<ul style="list-style-type: none"> Plan and prepare Earthing installation 	83. Prepare pipe earthing and measure earth resistance by earth tester / megger. (10 Hrs) 84. Prepare plate earthing and measure earth resistance by earth tester / megger. (10 Hrs) 85. Test earth leakage by ELCB and relay. (5 Hrs)	Importance of Earthing. Plate earthing and pipe earthing methods and IEE regulations. Earth resistance and earth leakage circuit breaker
37 - 38	<ul style="list-style-type: none"> Plan and execute electrical illumination system and test 	86. Install light fitting with reflectors for direct and indirect lighting. (10 Hrs) 87. Group different wattage of lamps in series for specified voltage. (5 Hrs) 88. Practice installation of various lamps e.g. fluorescent tube, HP mercury vapour, LP mercury vapour, HP sodium vapour, LP sodium vapour, metal halide etc. (18 Hrs)	Laws of Illuminations. Types of illumination system. Illumination factors, intensity of light. Type of lamps, advantages/ disadvantages and their applications. Calculations of lumens and efficiency

		<p>89. Prepare decorative lamp circuit using drum switches. (5 Hrs)</p> <p>90. Prepare decorative lamp circuit to produce rotating light effect/running light effect. (6 Hrs)</p> <p>91. Install light fitting for show case lighting. (6 Hrs)</p>	
39 - 40	<ul style="list-style-type: none"> Select and perform measurements using analog / digital instruments 	<p>92. Practice on various analog and digital measuring Instruments. (5 Hrs)</p> <p>93. Practice on measuring instruments in single and three phase circuits e.g. multi-meter, Wattmeter, Energy meter, Phase sequence meter and Frequency meter etc. (15 Hrs)</p> <p>94. Measure power in three phase circuit using two wattmeter methods. (8 Hrs)</p> <p>95. Measure power factor in three phase circuit by using power factor meter and verify the same with voltmeter, ammeter and wattmeter readings. (12 Hrs)</p> <p>96. Measure electrical parameters using tong tester in three phase circuits. (10 Hrs)</p>	<p>Classification of electrical instruments and essential forces required in indicating instruments. PMMC and Moving iron instruments. Measurement of various electrical parameters using different analog and digital instruments. Measurement of energy in three phase circuit</p>
41	<ul style="list-style-type: none"> Perform testing, verify errors and calibrate instruments 	<p>97. Practice for range extension and calibration of various measuring instruments. (10 Hrs)</p> <p>98. Determine errors in resistance measurement by voltage drop method. (8 Hrs)</p> <p>99. Test single phase energy meter for its errors. (7 Hrs)</p>	<p>Errors and corrections in measurement. Loading effect of voltmeter and voltage drop effect of ammeter in circuits. Extension of range and calibration of measuring instruments</p>
42 - 44	<ul style="list-style-type: none"> Plan and carry out installation, fault detection and repairing of domestic appliances 	<p>100. Dismantle and assemble electrical parts of various electrical appliances e.g. cooking range, geyser, washing machine and pump set. (25 Hrs)</p> <p>101. Service and repair of bell/ buzzer. (5 Hrs)</p> <p>102. Service and repair of electric iron, electric kettle,</p>	<p>Working principles and circuits of common domestic equipment and appliances. Concept of Neutral and Earth</p>

		<p>cooking range and geyser. (12 Hrs)</p> <p>103. Service and repair of induction heater and oven. (10 Hrs)</p> <p>104. Service and repair of mixer and grinder. (10 Hrs)</p> <p>105. Service and repair of washing machine. (13Hrs)</p>	
45 - 46	<ul style="list-style-type: none"> Execute testing, evaluate performance and maintenance of transformer 	<p>106. Verify terminals, identify components and calculate transformation ratio of single phase transformers. (8 Hrs)</p> <p>107. Perform OC and SC test to determine and efficiency of single phase transformer. (12 Hrs)</p> <p>108. Determine voltage regulation of single phase transformer at different loads and power factors. (12 Hrs)</p> <p>109. Perform series and parallel operation of two single phase transformers. (12 Hrs)</p> <p>110. Verify the terminals and accessories of three phase transformer HT and LT side. (6 Hrs)</p>	<p>Working principle, construction and classification of transformer.</p> <p>Single phase and three phase transformers.</p> <p>Turn ratio and e.m.f. equation.</p> <p>Series and parallel operation of transformer.</p> <p>Voltage Regulation and efficiency.</p> <p>Auto Transformer and instrument transformers (CT & PT).</p>
47	<ul style="list-style-type: none"> Execute testing, evaluate performance and maintenance of transformer 	<p>111. Perform 3 phase operation (i) delta-delta (ii) delta-star (iii) star-star (iv) star-delta, by use of three single phase transformers. (6 Hrs)</p> <p>112. Perform testing of transformer oil. (6 Hrs)</p> <p>113. Practice on winding of small transformer. (8 Hrs)</p> <p>114. Practice of general maintenance of transformer. (5 Hrs)</p>	<p>Method of connecting three single phase transformers for three phase operation.</p> <p>Types of Cooling, protective devices, bushings and termination etc.</p> <p>Testing of transformer oil.</p> <p>Materials used for winding and winding wires in small transformer</p>
48 - 49		<p>Project work / Industrial visit</p> <p>Broad Areas:</p> <ol style="list-style-type: none"> Overload protection of electrical equipment Automatic control of street light/night lamp Fuse and power failure indicator using relays Door alarm/indicator Decorative light with electrical flasher 	

Use of various types of cell

Objectives: At the end of this exercise you shall be able to

- read and interpret the different type of cells from the chart or physically available cells
- name the cells, parts and uses.

Requirements	
Equipments	Materials
<ul style="list-style-type: none"> • Different types of cells - 1 each 	<ul style="list-style-type: none"> • Chart showing different types of cells - 1 No.

PROCEDURE

Instructor may arrange the available different types of cells on the table. Explain the types of cells and their uses

- 1 Identify the type of cell and write their names to corresponding cell placed on the table or by referring from chart as in Table1 (Fig 1 to Fig 6)
- 2 Write the name of the parts against the number and uses in the blank space provided against each cell in table 1.

Table 1

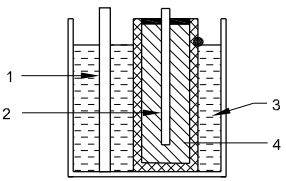
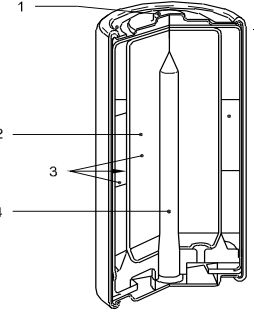
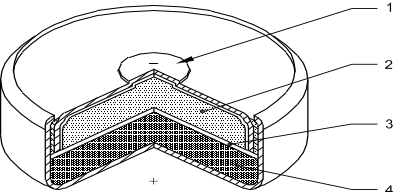
Sketches	Name of Cell	Parts of cell	Uses
<p>Fig 1</p>  <p>ELN2165H1</p>		<p>1</p> <p>2</p> <p>3</p> <p>4</p>	
<p>Fig 2</p>  <p>ELN2165H2</p>		<p>1</p> <p>2</p> <p>3</p> <p>4</p>	
<p>Fig 3</p>  <p>ELN2165H3</p>		<p>1</p> <p>2</p> <p>3</p> <p>4</p>	

Sketches	Name of Cell	Parts of cell	Uses
<p>Fig 4</p> <p style="text-align: right; font-size: small;">ELN2165F14</p>		<p>1</p> <p>2</p> <p>3</p> <p>4</p> <p>5</p>	
<p>Fig 5</p> <p style="text-align: right; font-size: small;">ELN2165F15</p>		<p>1</p> <p>2</p> <p>3</p> <p>4</p> <p>5</p>	
<p>Fig 6</p> <p style="text-align: right; font-size: small;">ELN2165F16</p>		<p>1</p> <p>2</p> <p>3</p> <p>4</p> <p>5</p>	

3 Get it checked by your instructor.

Practice on grouping of cells for specified voltage and current under different conditions and care

Objectives: At the end of this exercise you shall be able to

- make grouping of cells in series connection
- make grouping of cells in parallel connection
- make grouping of cells in series and parallel connection.

Requirements			
Tools/Instruments		Materials	
• MC Ammeter 0-1A	- 1 No.	• Cells 1.5V	- 8 Nos.
• MC Voltmeter 0-15V	- 1 No.	• SP Switch 6A, 250V	- 4 Nos
• MC Ammeter 500 mA	- 1 No.	• Connecting leads	- as reqd.
• Multimeter	- 1 No.	• Resistor 5 Ω , 10W	- 1 No.
• Rheostat 20 ohms 3.7A	- 1 No.	• 4 Cell battery pack	- 2 Nos.
		• miniature lamp 6V / 9V, 300 mA	- 1 No.
		• Resistor 10 Ω , 10W	- 1 No.

PROCEDURE

TASK 1 : Grouping of cells in series connection

- 1 Check the individual cells for their condition.
 - Select 500 mA DC current range in mulimeter or 500 mA DC ammeter.
 - Connect the cell across the meter in series with a 3 ohm resistor.
 - Watch the deflection.

Full deflection shows good condition of cell. Low deflection shows discharged condition of the cell.

Cells having a higher internal resistance should not be used for series connection. Care should be taken for the cells polarity.

- 2 Connect the cells as shown in Fig 1.
- 3 Measure the voltage of one cell V_1 , two cells V_2 , three cells V_3 and four cells V_4 connected in series.
- 4 Record your observations in the first and second columns of Table 1.

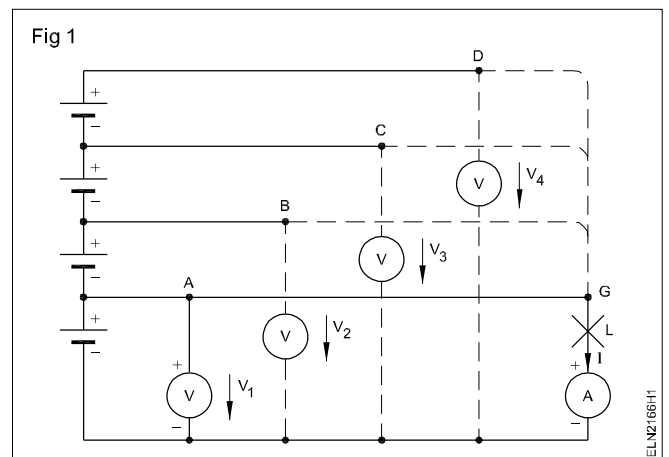

- 5 Connect the terminal 'G' to the terminal A and observe the ammeter reading and the glow condition of the lamp.
- 6 Change the contact of terminal ' G' terminals B,C and D in succession.
- 7 Record your observations under the columns 3 & 4 in Table 1

Table 1

SI No.	No. of cells in series	Voltmeter reading	Ammeter reading	Glow
1				
2				
3				
4				

TASK 2: Grouping of cells in parallel connection

- 1 Check the voltage of each cell.
- 2 Form the circuit as shown in Fig 2.

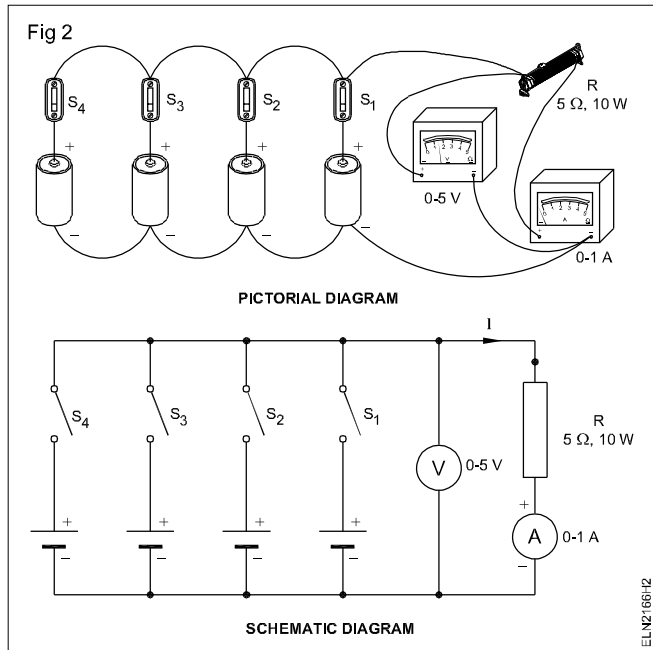

- 3 Close the switch S_1 and measure voltage and current. Record the values in Table 2, under columns 2, 3 and 4.

Table 2

Sl. No.	No. of Cells in Parallel	V	I

- 4 Check and record the readings of V and I after closing switch S_2 , then S_3 , and S_4 in succession.

Unequal voltage cells cannot be connected in parallel.

Conclusion

When cells of equal voltage are connected in parallel the terminal voltage is equal to _____

As the load current is shared by the cells in parallel, the terminal voltage across the load is _____ when compared to a single cell supplying current to the same load.

The effect of a number of cells in parallel to a given load.

TASK 3 : Grouping of cells in series and parallel combination connection

Series parallel combination is for higher voltage and higher current

- 1 Set the movable arm of 20 ohms 3.7A rheostat to get 12 ohms with the help of an ohmmeter.
- 2 Connect four 1.5 V cells in series to form one group. Form one more similar group of 4 cells. (Fig 3)
- 3 Connect two series groups of 4 cells and form the circuit as shown in Fig 3.
- 4 Close switch S_1 , observe the voltmeter and ammeter. Record the values in row 1 of Table 3
- 5 Keep the switch positions S_1 , S_2 and S_3 as indicated in row 2 of Table 3. Record V and I in the respective columns.
- 6 Repeat step 5 for different combinations of switch positions as indicated in rows 3 to 6 of Table 3.

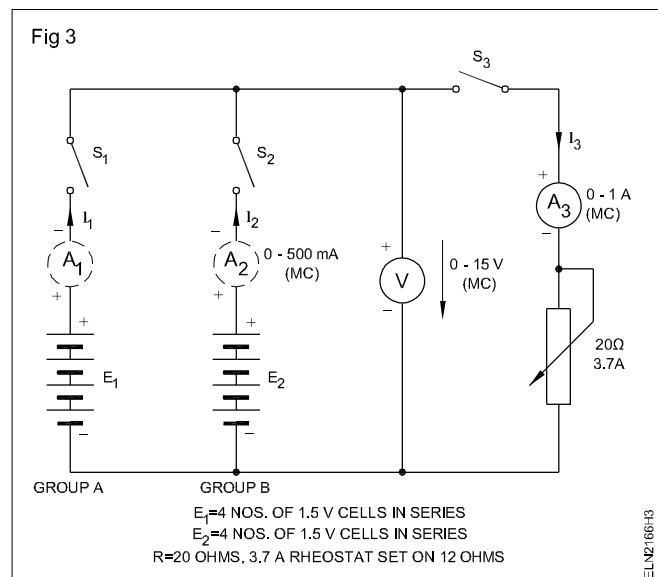

Both the open circuit voltages of group (a) and group (b) should be the same, or more correctly their Terminal Potential Difference should be the same when supplying the same load current.

This indicates that the internal resistance of group 'A' is _____ the internal resistance of group 'B'

The no-load voltage in series-parallel combination _____

The total current drawn by the load is equal to the sum of the _____

Conclusion

When group 'A' alone supplies the load current, the fall in voltage (EMF - TPD) is _____

When group 'B' alone supplies the load current the fall in voltage (EMF - TPD) is _____

Table 3

Row	Position of the switches			I ₁	I ₂	V
	S ₁	S ₂	S ₃			
1	Close	Open	Open			
2	Close	Open	Close			
3	Open	Close	Open			
4	Open	Close	Close			
5	Close	Close	Open			
6	Close	Close	Close			

Prepare and practice on battery charging and details of charging circuit

Objectives: At the end of this exercise you shall be able to

- connect and charge the battery by using a battery charger
- connect and charge the battery by the constant current method
- connect and charge the battery by the constant potential method
- prepare of electrolyte.

Requirements	
<p>Tools/Instruments</p> <ul style="list-style-type: none"> • Cutting plier 150 mm - 1 No. • Screw driver 150 mm - 1 No. • MC Voltmeter 0-15V - 1 No. • MC Ammeter 0-10A - 1 No. • Hydrometer - 1 No. • High rate discharge tester - 1 No. <p>Equipment/Machines</p> <ul style="list-style-type: none"> • Battery charger for 12V - 1 No. • Low voltage DC power supply 0-30 volts 10A. - 1 No. • Variable resistor 10 ohms, 5A capacity - 1 No. • Battery 12V lead acid type - 1 No. 	<p>Materials</p> <ul style="list-style-type: none"> • Distilled water - 1 bottle (450ml) • Petroleum jelly - as reqd. • Sandpaper - as reqd. • Test leads with crocodile clips - 1 pair • Clips - 1 pair • concentrated sulphuric acid - 100 ml • Clean jar for mixing 1 litre capacity - 2 Nos. • Cotton Waste - as reqd. • Soda bi-carbonate - as reqd.

PROCEDURE

TASK 1 : Charging a battery using a battery charger

- 1 Clean the battery terminals, if corroded, with sandpaper : if sulphated, clean with wet cotton waste or with soda bicarbonate.

Do not damage the battery terminal by scraping with any metal strip.

- 2 Unscrew all the vent plugs and check the level of the electrolyte.

Do not clean the battery top surface keeping the vent plugs open. The accumulated dirt may fall inside the cells and form sediments.

- 3 Top up the electrolyte to the marked level in all the cells with distilled water.

No electrolyte to be used to top up battery.

- 4 Check the initial specific gravity of the electrolyte of each cell using a hydrometer (Fig 1) and record in Table 1.

- 5 Measure the cell voltage and the battery voltage with a voltmeter and record in the Table 1.

Do not use a high rate discharge tester for measuring voltage.

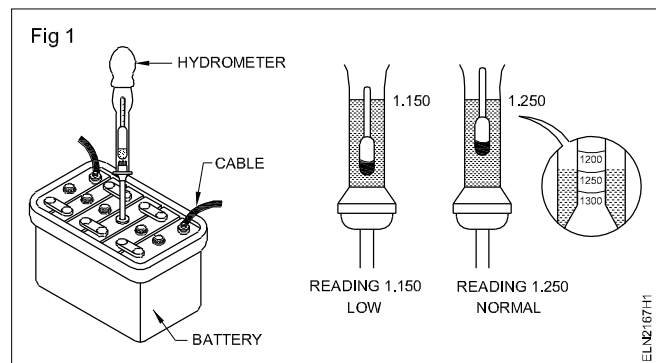

- 6 Connect the battery charger's +ve lead to the +ve terminal of the battery and the -ve lead of the charger to the -ve terminal of the battery. (Fig 2)
- 7 Adjust the battery charger output voltage equal to or a little higher than the voltage of the battery to be charged.
- 8 Set the charger voltage to produce the determined value of initial charging current.

Follow the manufacturer's recommendation for current setting for charging as well as discharging.

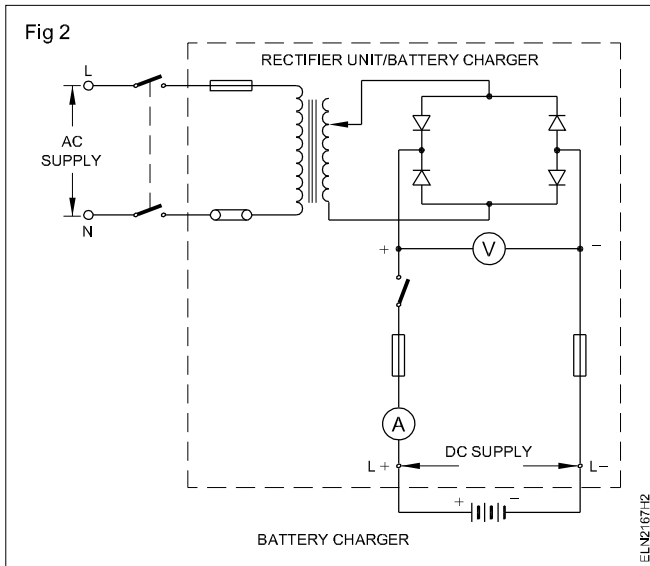

9 Check the voltage of each cell of the battery and specific gravity of the electrolyte at regular intervals (say ONE hour).

Remove the vent plug to enable the gas to escape.

10 Disconnect the battery when fully charged. Fit the vent plugs, clean the outer surface with wet cloth. Apply petroleum jelly to the terminals.

11 Check the battery for its working voltage under load using a high rate discharge tester for a short period. (Fig 3)

Do not keep a high rate discharge tester for along period, say more than five seconds.

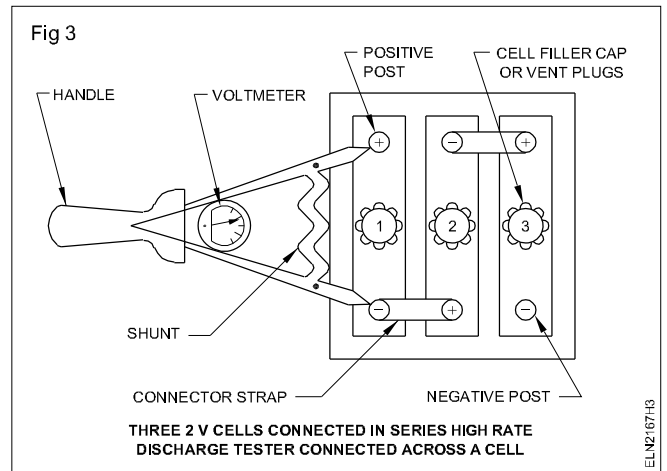

Table 1

Cell No.	Initial condition		Charged condition after									
	Specific gravity	Voltage	1 Hr		2 Hrs		3 Hrs		4 Hrs		5 Hrs	
			SP	V	SP	V	SP	V	SP	V	SP	V
1												
2												
3												
4												
5												
6												

TASK 2 : Charge a battery by constant current method

- 1 Form the circuit as shown in Fig 4.
- 2 Clean the battery terminals and unscrew all the vent plugs.
- 3 Check the level of the electrolyte and top up.
- 4 Check the specific gravity and voltage of each cell and record and prepare a blank table (as shown in Table 1).
- 5 Connect the given batteries in series with the lamp bank as per Fig 4.
- 6 Adjust the current rating through the lamp bank.

7 Set the lamp bank to produce the determined value of the initial charging current.

Don't touch the battery terminals since the circuit is connected to 220V DC.
Proper protective devices should be provided in the circuit.

- 8 Read the voltage and specific gravity of each cell at regular intervals and record in Table 1.
- 9 Repeat the steps 10 and 11 of Task 1.

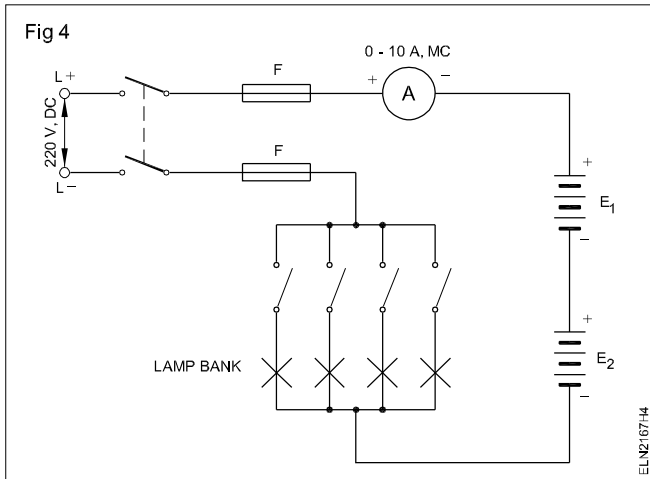

TASK 3 : Charge a battery by constant potential method

- 1 Form the circuit as shown in Fig 5.
- 2 Repeat the steps 2 to 4 of Task 2.
- 3 Adjust the voltage by adjusting the rheostat to the required value.
- 4 Read and record the voltage, current and specific gravity at regular intervals in Table 3. (Prepare a blank table as shown in Table 1)
- 5 Repeat the steps 10 and 11 of Task 1.

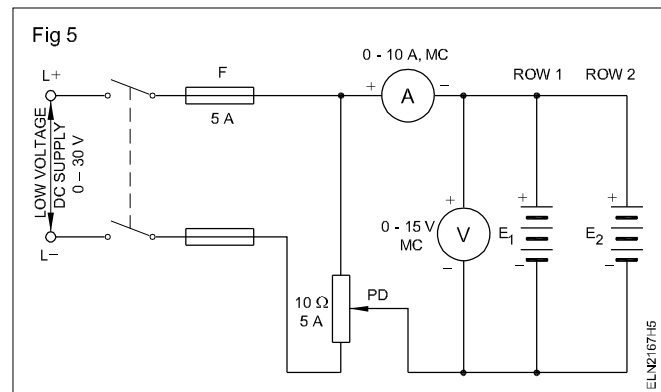

TASK 4 : Preparation of electrolyte

- 1 Prepare the necessary materials for electrolyte preparation.
- 2 Fill distilled water of the required quantity in the glass jar.
- 3 Add concentrated sulphuric acid little by little to the water and stir with a glass rod simultaneously.
- 4 Allow the mixture to cool sufficiently to the ambient temperature.
- 5 Read the specific gravity (Fig 1). If the specific gravity is below 1250, add a little more acid to bring to the correct specific gravity.

Don't pour excess acid at a time to the water to avoid excess generation of heat.

Take care not to sprinkle the electrolyte.

Practice on routine, care / maintenance and testing of batteries

Objectives: At the end of this exercise you shall be able to

- **prepare and follow the routine care/maintenance schedule chart for batteries**
- **carry out the general procedure and maintenance for batteries.**

Requirements			
Tools/Instruments		Equipment/Machines	
<ul style="list-style-type: none"> • Ring spanner (6 mm - 25 mm) • Combination pliers 150mm • Insulated screw driver 200mm • Hydrometer • High rate discharger tester 	<ul style="list-style-type: none"> - 1 Set - 1 No. - 1 No. - 1 No. - 1 No. 	<ul style="list-style-type: none"> • Lead acid battery 12V / 60 AH 	<ul style="list-style-type: none"> - 1 No.
		Materials	
		<ul style="list-style-type: none"> • Banian cloth • Distilled water • Sodium bicarbonate solution 	<ul style="list-style-type: none"> - as reqd. - as reqd. - as reqd.

PROCEDURE

TASK 1: Prepare and follow the routine care/maintenance schedule chart for batteries

- 1 Collect the care/maintenance activities required for lead acid batteries.
- 2 Make a care/maintenance chart for daily, weekly, monthly, six monthly maintenance schedule as in chart - 1.
- 3 Perform the routine care/maintenance activities of battery by referring the following chart 1.

Routine Care/ Maintenance Schedule Chart-1

Sl.No.	Routine	Activities to be done	Remarks
1	Daily	<ul style="list-style-type: none"> • Inspect the batteries visually. • If it is found abnormal, report and do necessary action. 	
2	Weekly	<ul style="list-style-type: none"> • Inspect all batteries visually • Clean surface, check tightness of connectors and vent plugs • Check supporting clamps 	
3	Monthly	<ul style="list-style-type: none"> • Check level of electrolyte • Do charging of battery, if not been automatically charged • Clean terminals, reconnect, apply protection jelly. • Clean top surface by sodium bi carbonate solution in water. • Wipe surface for dryness. • Check that other materials surface should not have contact with batteries and top surface of battery 	
4	Six Monthly	<ul style="list-style-type: none"> • Check level and specific gravity, charging rate, charging hours, voltage cell 	

(Life of well maintained lead acid battery can be about five to six years)



TASK 2 : Carry out the general preventive maintenance of lead acid battery

1 Perform the following steps for the preventive maintenance of battery.

Steps to be followed for preventive maintenance of battery

- Maintain the level of the electrolyte 10 to 15 mm above the plates (or) as per manufacturer's manual.
- Add the distilled water to the acid; and do not add acid to water.
- Connect the positive terminal of the battery to the positive terminal of the supply, and connect the negative terminal of the battery to the negative terminal of the supply while charging the battery.
- Keep the vent plug open for the liberation of gases during charging.
- Clean the vent plugs holes for proper discharging of gas.
- Keep the battery terminals always cleaned.

- Apply a thin layer of Vaseline (or) petroleum jelly over them to prevent corrosion.
- Do not charge or discharge the battery in higher rate continuously.
- Remove the lead sulphate which is formed due to over charge after four months.
- Maintain well-ventilated room for battery charging.
- Use high rate discharge tester only for charged battery not for discharged battery.
- Check the specific gravity of the electrolyte before charging and discharging.

Determine the number of solar cells in series / Parallel for given power requirement

Objectives: At the end of this exercise you shall be able to

- determine the number of solar cells required for a series group for a given voltage requirement
- determine the number of group of solar cells in parallel for a given ampere hour capacity
- calculate the total number of solar cells required for a given power requirement
- connect the given cells in series and parallel groups to charge the battery.

Requirements	
<p>Tools/Instruments</p> <ul style="list-style-type: none"> • Cutting pliers 200 mm - 1 No. • Screw driver 250 mm - 1 No. • Connector screw driver 100 mm - 1 No. • Voltmeter MC type 0 - 15V - 1 No. • Ammeter 0-500 mA - MC - 1 No. • Soldering Iron 35W 240V 50 Hz - 1 No. 	<p>Materials/Components</p> <ul style="list-style-type: none"> • Solar cells 125 mW/cm², 0.45 V, 57 mA - 87 cells • Connecting wires 3/0.91 mm PVC insulated cable - 20 m • Insulation tape 30 cm long - 1 No. • Miniature bulb B.C Type 3W 12 V - 1 No. • 'On' and 'Off' flush mounting switch 6A 240 Volts - 2 Nos. • Resin core solder 60:40 - as reqd.

PROCEDURE

TASK 1 : Determine the number of cells required for a series group

A village panchayat office requires a light of 12V 3Watts for display purpose for four hours which has to be energized through a battery. The battery is to be charged through an array of solar cells having 125 mw/cm² capacity. The light from sun expected to be available for 8 hours a day. Calculate the number of solar cells in series group and the number of groups in parallel to charge the battery and wire up the solar cells accordingly.

1 Determine the number of solar cells in series group.

$$\text{No. of cells in series group} = \frac{\text{Total required voltage}}{\text{Volt per cell}}$$

Assuming charging voltage is equal to battery voltage + 1 volt = 12 + 1 = 13 V

$$\text{No. of cells in series group} = \frac{13}{0.45} = 29 \text{ cells}$$

Calculate the ampere hour requirement

$$\text{The current required} = \frac{\text{Power}}{\text{Voltage}} = \frac{3 \text{ watts}}{12 \text{ volts}} = \frac{1}{4} \text{ amps}$$

say 250 mA

The charge taken from the batteries at the rate of 250 mA for 4 hours

$$\text{Hence ampere hour requirement} = \frac{250}{1000} \times 4 = 1 \text{ AH}$$

$$\begin{aligned} \text{Charging current rating} &= \frac{\text{ampere hour lost in actual usage}}{\text{No. of possible charging hours}} \\ &= \frac{1 \text{ AH}}{8} = 0.125 \text{ amperes} \end{aligned}$$

$$\begin{aligned} \text{Total No. of cells in parallel group} &= \frac{\text{Output current}}{\text{Cell current}} \\ &= \frac{0.125 \text{ amp}}{57 \text{ mA}} \\ &= \frac{125}{57} = 2.2 \\ &= \text{say 3 cells/group} \end{aligned}$$

$$\begin{aligned} \text{Hence total number of cells required} &= 29 \times 3 \\ &= 87 \text{ cells} \end{aligned}$$

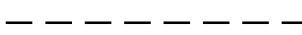

TASK 2 : Connect the given 87 cells in series parallel groups to charge the 12 v battery

- 1 Connect 29 cells in a series group and solder the points.
- 2 Make 3 groups of 29 cell series groups.
- 3 Connect the three series groups in parallel and solder the connections ends.
- 4 Connect the series parallel group of cells with a voltmeter, an ammeter, battery and a 6A Switch as shown in the Fig 1.
- 5 Measure the voltage across the groups with the help of 0-15 V M.C. voltmeter and enter the values in Table 1.
- 6 Close the switch and measure the charging current and enter the values in Table 1.

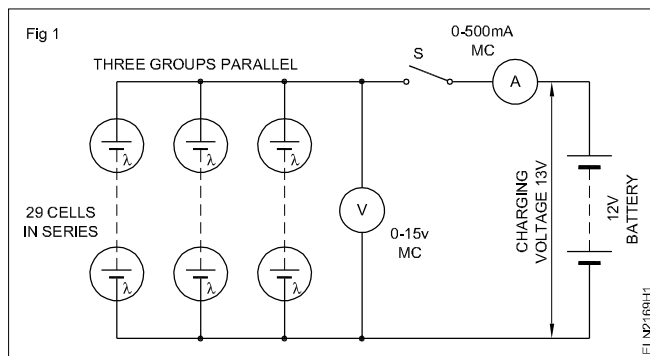

Table 1

Open circuit voltage of coils	Load voltage	Charging current

Identify various conduits and different Power accessories

Objectives: At the end of this exercise you shall be able to

- identify and name the conduits and conduit accessories and write their specification and uses.
- identify and name the Power accessories
- write the specification and uses of the Power accessories
- draw the Power accessories IE symbols.

Requirements	
Tools/Instruments	
<ul style="list-style-type: none"> • Insulated screw driver 4mm x150mm - 1 No. • Insulated connector screw driver 4 mm x100 mm - 1 No. • Tray 60x30x4 cm - 1 No. • I.S. books on graphic symbols (B.I.S 2032 all parts) - 1 No. 	<ul style="list-style-type: none"> • Tube light starter holder 6A - 1 No. • Combined tube and starter holder 6A - 1 No. • Tube light holder - 6A - 1 No. • Brass batten-holder 6A 250V - 1 No. • Bakelite batten-holder 6A 250V - 1 No. • Brass pendent-holder 6A 250V - 1 No. • Bakelite pendent-holder 6A 250V - 1 No. • 3-pin 6A wall socket, mounting type - 1 No. • 3-pin 16A wall socket, mounting type - 1 No. • 3-pin 6A wall socket, flush type - 1 No. • 3-pin 16A wall socket, flush type - 1 No. • 2-pin 6A wall socket, flush type - 1 No. • 2-pin 6A mounting type - 1 No. • Ceiling rose 6A 250V 2 plate - 1 No. • Ceiling rose 6A 250V 3 plate - 1 No. • Fan regulator - 1 No. • Kit-kat fuse 16A 250V - 1 No. • Intermediate switch 6A 250V - 1 No. • 3-pin 6A 250 V plug - 1 No. • 3-pin 16A 250 V plug - 1 No. • Terminal plate 16A 250 V 3- way - 1 No. • I.C.D.P. switch 16A 250V - 1 No. • I.C.T.P. switch 16A 400V - 1 No. • Neutral link 16 amps - 1 No. • I.C. cutouts 16A 250V - 1 No. • Distribution box 4-way - 1 No. • Bell-Push/switch 6A, 250V flush type - 1 No. • Bell-Push/switch 6A, 250V mounting type - 1 No. • HRC Fuse - 16A - 1 No. • Iron connector - 5A - 1 No. • Toggle switch 6A - 1 No. • MCB 1,2 & 3 Pole - 1 No. each
Materials	
<ul style="list-style-type: none"> • PVC conduit pipe - 19 mm and 25 mm - 3M long - 1 No. each • GI conduit pipe - 19 mm and 25mm - 3 m long - 1 No. each • PVC Channel - 20mm and 25mm - 1M long - 1 No. each • PVC pipe coupling - 19mm & 25mm - 1 No. each • PVC junction box - 1,2,3 and 4 way -19mm & 25mm - 1 No. each • PVC bend - 19 mm & 25mm - 1 No. each • PVC Elbow - 19 mm & 25 mm - 1 No. each • PVC Tee - 19mm & 25mm - 1 No. each • GI conduit coupler & Inspection Coupler - 19mm & 25mm - 1 No. each • GI Elbow & Inspection Elbow - 19mm & 25mm - 1 No. each • Tees & Inspection Tee - 19mm & 25mm - 1 No. each • GI junction box -1,2,3 & 4 way square type 19mm & 25mm - 1 No. each • S.P. switch 6A 250V flush type, single way - 1 No. • S.P. switch 6A 250V flush type two way - 1 No. • S.P. switch 6A 250V mounting type single way - 1 No. • S.P. switch 6A 250V mounting type two-way - 1 No. 	

PROCEDURE

TASK 1 : Identify various conduit and conduit accessories

- 1 Identify each items and write the name in the table. (Fig 1 to Fig 11)
- 2 Write the specification and use of each conduit & conduit accessory in the column given.

Conduit Pipe & Conduit accessories

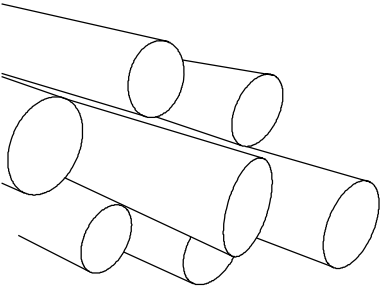
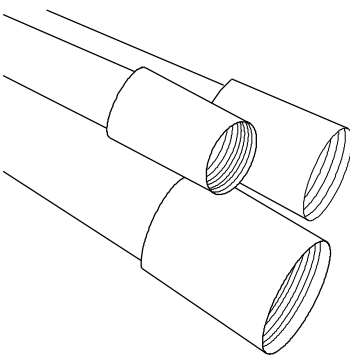
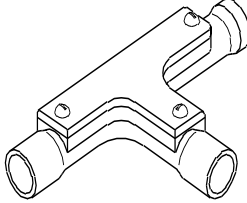
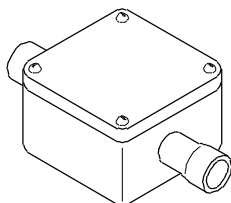
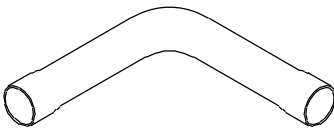
Sketch	Name	Specification	Use
<p>Fig 1</p>  <p style="text-align: right; font-size: small;">ELN2270-H1</p>			
<p>Fig 2</p>  <p style="text-align: right; font-size: small;">ELN2270-H2</p>			
<p>Fig 3</p>  <p style="text-align: right; font-size: small;">ELN2270-H3</p>			
<p>Fig 4</p>  <p style="text-align: right; font-size: small;">ELN2270-H4</p>			
<p>Fig 5</p>  <p style="text-align: right; font-size: small;">ELN2270-H5</p>			

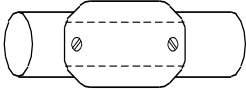
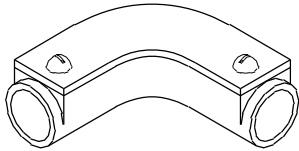
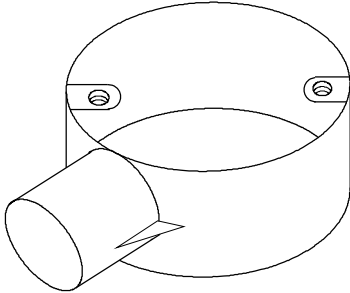
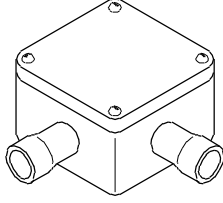
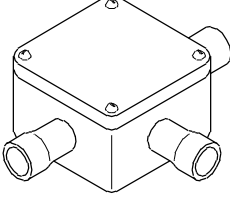
Sketch	Name	Specification	Use
<p data-bbox="183 219 236 250">Fig 6</p>  <p data-bbox="802 318 820 407" style="writing-mode: vertical-rl; transform: rotate(180deg);">ELN2270-H6</p>			
<p data-bbox="183 468 236 499">Fig 7</p>  <p data-bbox="802 593 820 683" style="writing-mode: vertical-rl; transform: rotate(180deg);">ELN2270-H7</p>			
<p data-bbox="183 741 236 772">Fig 8</p>  <p data-bbox="802 1064 820 1153" style="writing-mode: vertical-rl; transform: rotate(180deg);">ELN2270-H8</p>			
<p data-bbox="183 1202 236 1234">Fig 9</p>  <p data-bbox="802 1377 820 1467" style="writing-mode: vertical-rl; transform: rotate(180deg);">ELN2270-H9</p>			
<p data-bbox="183 1509 236 1541">Fig 10</p>  <p data-bbox="802 1668 820 1758" style="writing-mode: vertical-rl; transform: rotate(180deg);">ELN2270-HA</p>			

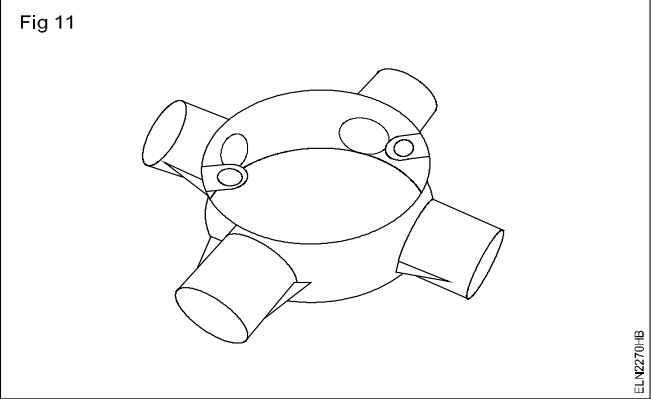
Sketch	Name	Specification	Use
<p>Fig 11</p> 			

TASK 2 : Identify Power accessories and write their names

1 Identify each accessory and write the name in the table 2 (Fig 12 to 30)

2 Write the specification of each accessory in the column given by the side of each (accessory) figure.

Different manufacturers design the outline of accessories differently to suit various conditions. However, the Power contact positions of the accessories remain the same. As such there should not be much difficulty in identifying the accessories.

On the other hand, single way and two-way switches as well as two and three plate ceiling roses look alike. A careful look at the rear of the accessory will make the identifying process much easier.

Most of the specifications can be collected from the markings on the accessory itself. Otherwise try to get them from an approved catalogue or approach the instructor for guidance.

3 Identify the I.E symbols used for the accessory from the related theory or B.I.S.books and sketch the symbols in the columns/spaces provided.

4 Show the completed sheets of specifications, identification and symbols to the instructor and get his approval.

Table 2 - Power accessories

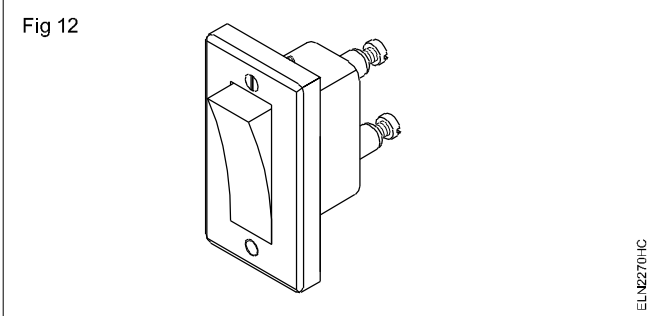
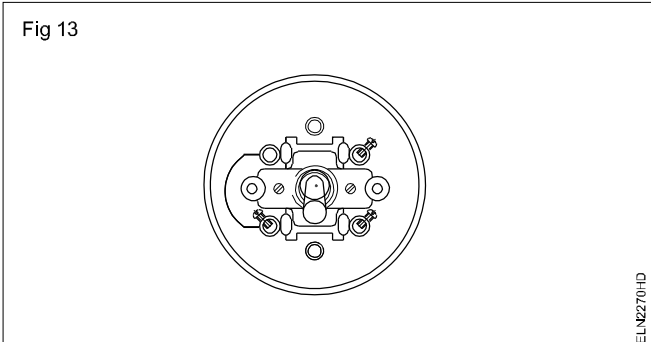
Sketch	Name	Specification	Use	IE Symbol
<p>Fig 12</p> 				
<p>Fig 13</p> 				

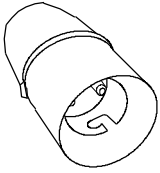
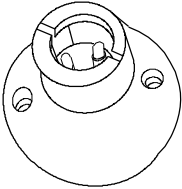
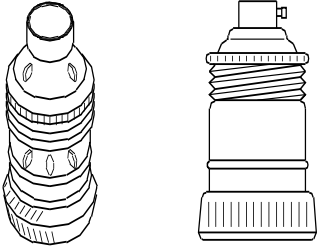
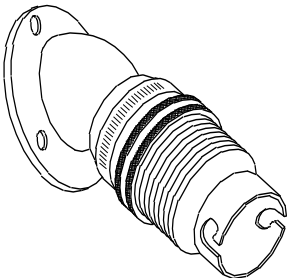
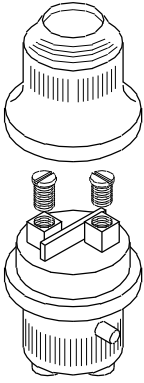
Sketch	Name	Specification	Use	IE Symbol
<p data-bbox="188 206 255 232">Fig 14</p>  <p data-bbox="817 407 829 448">ELN2270E</p>				
<p data-bbox="188 497 255 524">Fig 15</p>  <p data-bbox="817 694 829 734">ELN2270F</p>				
<p data-bbox="188 801 255 828">Fig 16</p>  <p data-bbox="807 1025 820 1133">ELN2270HG</p>				
<p data-bbox="188 1227 255 1254">Fig 17</p>  <p data-bbox="807 1460 820 1545">ELN2270HH</p>				
<p data-bbox="188 1639 255 1666">Fig 18</p>  <p data-bbox="807 1966 820 2029">ELN2270H</p>				

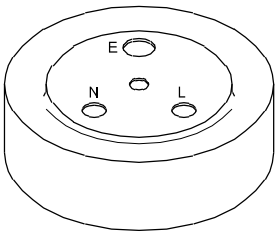
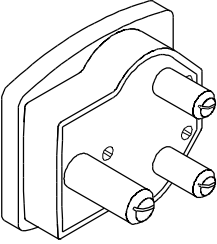
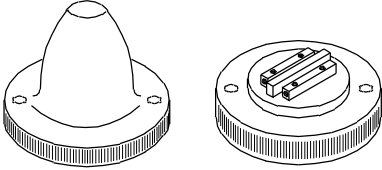
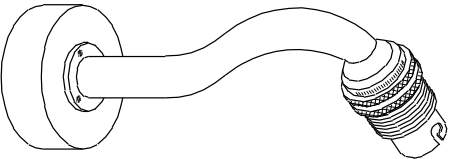
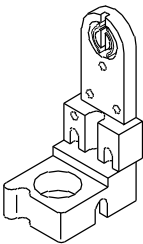
Sketch	Name	Specification	Use	IE Symbol
<p data-bbox="116 219 177 248">Fig 19</p>  <p data-bbox="730 421 746 488">ELN2270HU</p>				
<p data-bbox="116 600 177 629">Fig 20</p>  <p data-bbox="730 835 746 902">ELN2270HK</p>				
<p data-bbox="116 1014 177 1043">Fig 21</p>  <p data-bbox="730 1155 746 1223">ELN2270HL</p>				
<p data-bbox="116 1328 177 1357">Fig 22</p>  <p data-bbox="722 1473 738 1541">ELN2270HM</p>				
<p data-bbox="116 1648 177 1677">Fig 23</p>  <p data-bbox="730 1861 746 1928">ELN2270HN</p>				

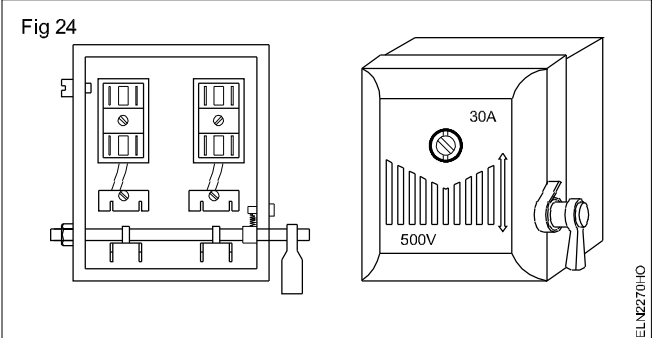
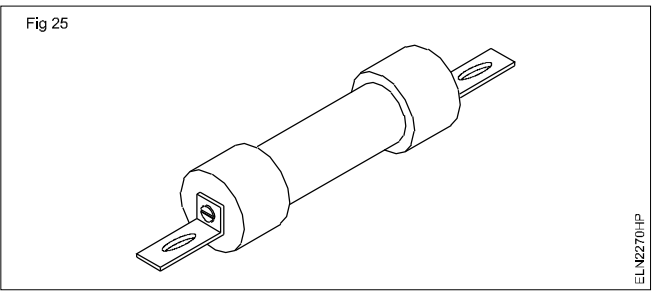
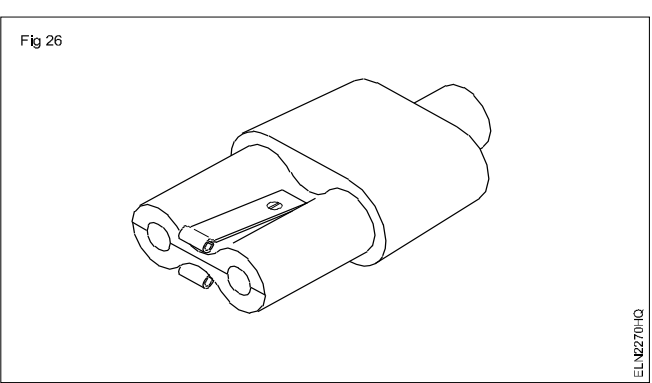
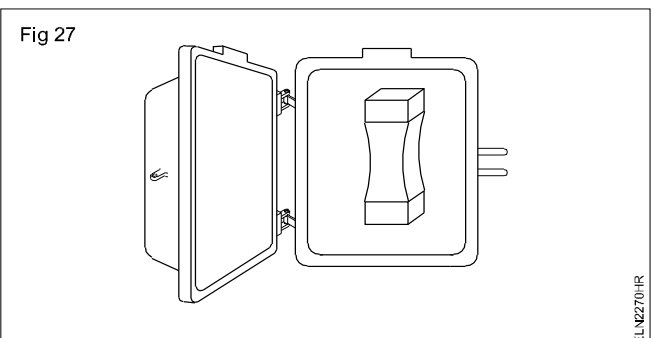
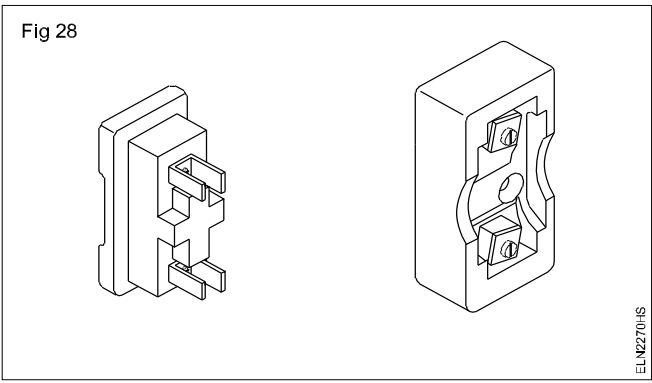
Sketch	Name	Specification	Use	IE Symbol
<p>Fig 24</p>  <p>ELN2270HO</p>				
<p>Fig 25</p>  <p>ELN2270HP</p>				
<p>Fig 26</p>  <p>ELN2270HQ</p>				
<p>Fig 27</p>  <p>ELN2270HR</p>				
<p>Fig 28</p>  <p>ELN2270HS</p>				

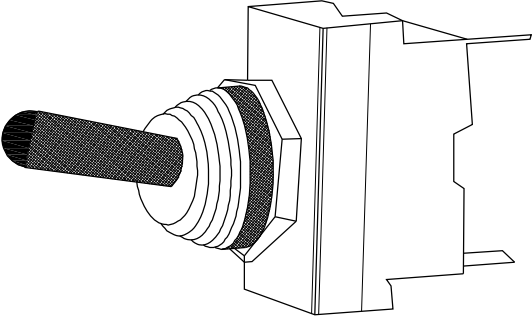
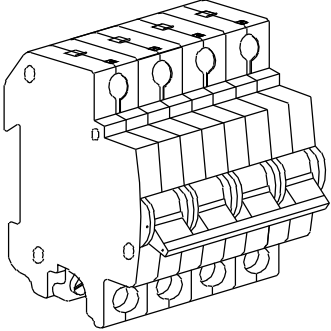
Sketch	Name	Specification	Use	IE Symbol
<p data-bbox="113 226 172 248">Fig 29</p>  <p data-bbox="730 651 746 723" style="writing-mode: vertical-rl; transform: rotate(180deg);">ELN4270-HT</p>				
<p data-bbox="121 808 169 831">Fig 30</p>  <p data-bbox="730 1182 746 1254" style="writing-mode: vertical-rl; transform: rotate(180deg);">ELN4270-HU</p>				

Practice cutting, threading of different sizes of conduits and laying installations

Objectives: At the end of this exercise you shall be able to

- cut metal conduit pipes of heavy gauge to the required dimensions
- fasten the conduit pipe in the pipe vice and prepare the conduit ends for threading
- cut the threads on heavy gauge metal conduit, according to requirements using a conduit die set
- fix the conduit accessories to the pipes according to the pipe size using the threaded method
- fix the conduit with the necessary clamps and spacers on surface installation in accordance with the B.I.S. recommendations
- draw cables in the metallic conduit pipes
- bond the conduit pipes at joints and junctions
- earth the conduit as per B.I.S. recommendations
- prepare metal boxes and fix Power accessories
- terminate the cable ends at the accessories according to the wiring diagram
- test the wiring.

Requirements	
Tools/Instruments	
<ul style="list-style-type: none"> • Screwdriver 200mm with 5mm blade - 1 No. • Connector screwdriver 100mm with 3mm blade - 1 No. • Pipe vice 50 mm - 1 No. • Steel rule 300 mm - 1 No. • Hacksaw with a blade of 24 teeth per 25 mm (25 TPI) - 1 No. • Flat file bastard 250 mm - 1 No. • Half round file 2nd cut 200 mm - 1 No. • Reamer 16 mm - 1 No. • Oil can 250ml - 1 No. • Conduit stock and dies for 19 mm & 25 mm conduit - 1 Set • Wire brush 50 mm - 1 No. • Plumb bob with thread - 1 No. • Electrician's knife DB 100 mm - 1 No. • Poker 200 mm - 1 No. • Ball peen hammer 500 grams - 1 No. • Hand drilling machine 6 mm capacity with 4 mm drill bit - 1 Set • Scriber 200 mm - 1 No. • Combination pliers 200 mm - 1 No. 	<ul style="list-style-type: none"> • Metal Box 90 mm Square of hexagonal type with top cover - 4 Nos. • Conduit pipe inspection Tee 19 mm - 3 Nos. • Conduit elbow 19 mm - 4 Nos. • Conduit bend 19 mm - 1 No. • Conduit junction box 3-way 19 mm - 4 Nos. • T.W. spacers 60mm long 19 mm width and 12mm thick - 25 Nos. • Tinned copper wire 14 SWG - 12 mts. • Earth clamps, tinned copper suitable for 19 mm pipe with bolt, nut and washers - 3 doz. • G.I. saddles 19 mm - 25 Nos. • Wood screws and machine screws assorted - as reqd. • P.V.C. aluminium cable 1.5 sqmm 250 V grade - 18 mts. • S.P.T. switch 6A 250V - 1 No. • Two-way Flush type switch 6A 250V - 3 Nos. • Ceiling rose 2-way 6A 250V - 4 Nos. • Pendent-holder, bakelite 6A 250V - 4 Nos. • B.C. bulbs 40W, 230V - 4 Nos. • Colour chalk - 1 piece • Terminal plate 16 amps 3-way - 1 No. • G.I. wire as fish wire 14 SWG - 6 mts. • P.V.C. bushes suitable for 19 mm pipe - 40 Nos. • Conduit check-nut 19 mm - 8 Nos. • Lubricant coconut oil - 100 gm • Cotton Waste - as reqd.
Materials	
<ul style="list-style-type: none"> • Conduit pipe, heavy gauge 19 mm dia. - 6 m • Conduit pipe, heavy gauge 25 mm dia - 3 m 	

PROCEDURE

TASK 1: Preparation of conduit pipe for cutting

Assume the job needs a 300 mm long conduit drop but a standard length pipe of 3000 mm is only available. Normally both the ends of a standard length pipe will have threads. To

make the required conduit drop, the standard length 3000 mm pipe is to be cut for a length of 300 mm and threaded again at one end.

Cutting could be done either by pipe cutters or with hacksaws. In practice, cutting with a hacksaw is popular, and the method is explained below.

- 1 Measure 300mm from the threaded end of the 19 mm pipe and mark it with chalk as shown in Fig 1.

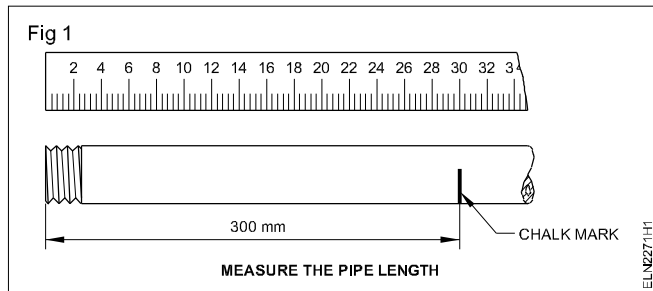

- 2 Open the jaw of the vice and insert the pipe so that it is horizontal and parallel to the jaw serrations.
- 3 Keep the chalk mark of the pipe within 100 mm of the vice as shown in Fig 2.

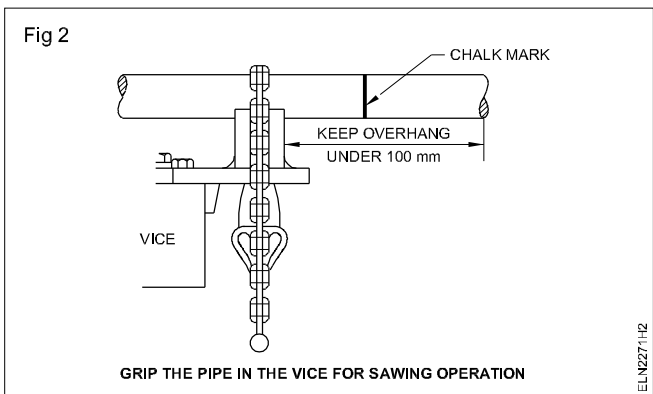

- 4 Close and tighten the vice jaw.
- 5 Select a hacksaw with a blade having 24 teeth per 25mm (25 TPI), as shown in Fig 3.

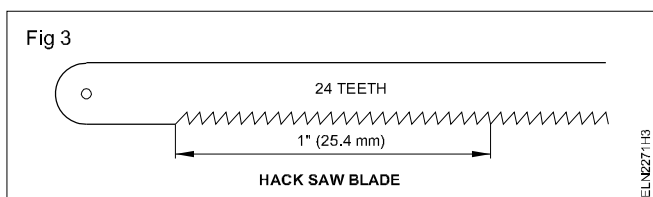

Ensure that the hacksaw blade is firmly tightened in the frame and that the teeth point in the forward direction.

- 6 Take up the hacksaw and position yourself, as shown in Fig 4, with your left shoulder pointing in the direction of the cut. Note the position of the feet, which allows for free and controlled movement of the body when cutting.
- 7 Grip the hacksaw handle with the right hand and position the hacksaw blade on top of the cutting line.
- 8 Prepare to cut by guiding the blade with the thumb of your left hand exactly on the cutting line against the saw blade as shown in Fig 5.

Fig 4

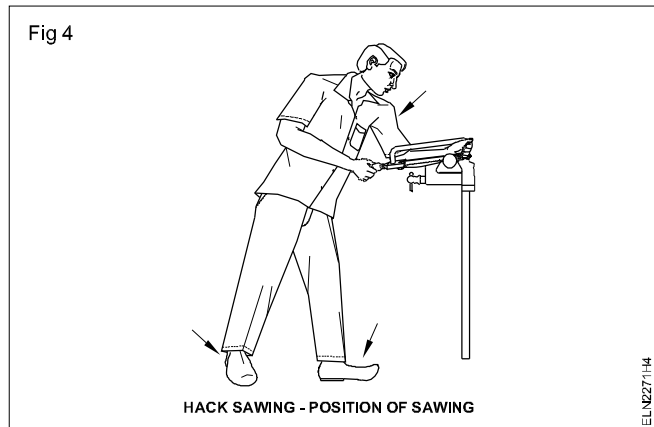
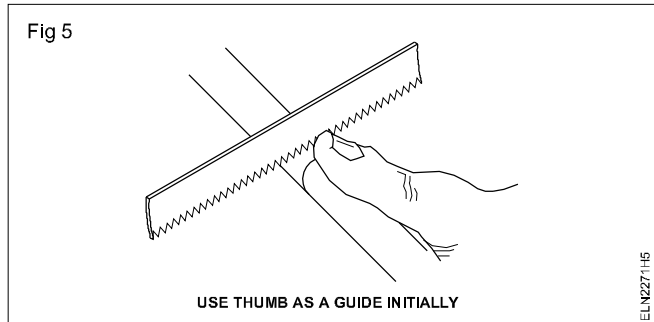
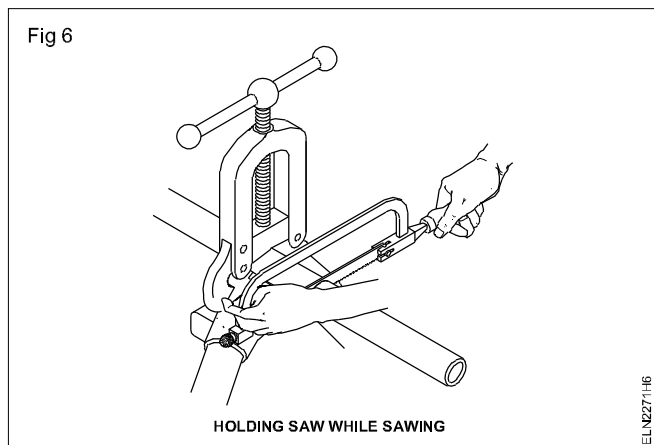

Fig 5



- 9 When the initial cut has been made, move the left hand to the front end of the hacksaw frame and use both hands for the cutting operation as shown in Fig 6.
- 10 When sawing, use the full length of the blade, increasing gradually the pressure on the forward stroke, and releasing the pressure as the blade is drawn back. (Fig 6)

Fig 6



- 11 Saw with steady, even strokes, keeping the blade upright and square to the cut as shown in Fig 7.

Fig 7

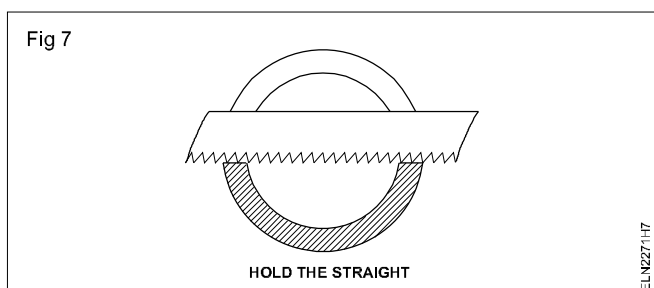

12 When getting near to the end of the cut, the conduit must be supported with your left hand as shown in Fig 8. Finish the cut.

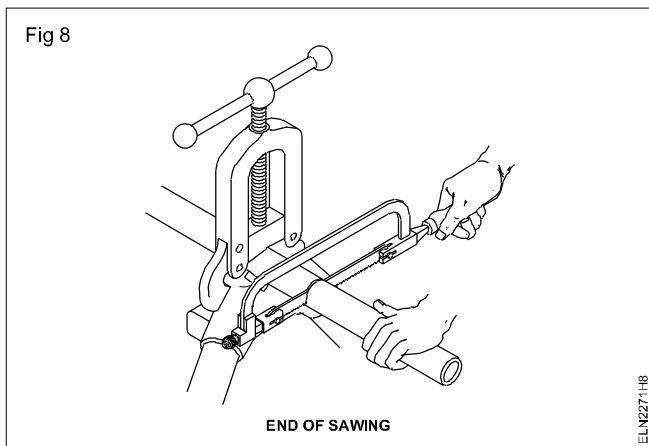

Support the free end of the conduit to prevent the blade of the hacksaw from being damaged.

- 13 Use a reamer or half round file to remove the inside burrs as shown in Fig 9.
- 14 Use the flat portion of the half round file to smoothen the sharp edges. (Fig 10)
- 15 Again follow the steps 2 to 14 for cut the 300 mm long from the threaded end of 25 mm dia. 3 m long pipe.

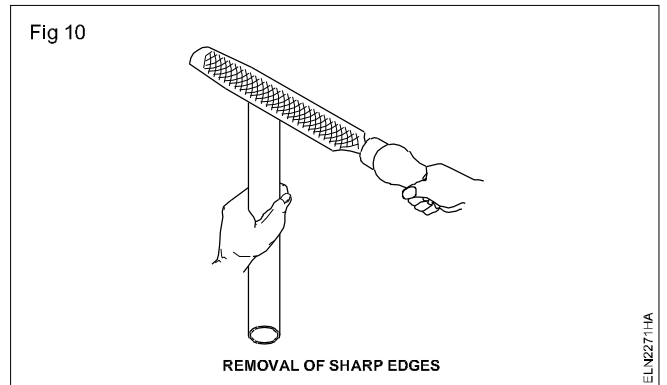
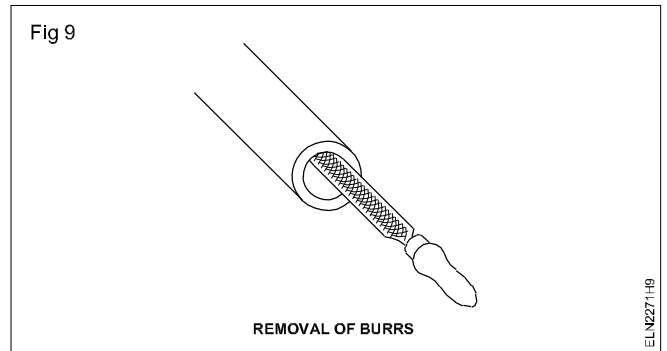

16 Clean the hacksaw and vice after the end of the work and keep them in their respective places.

TASK 2 : Preparation of conduit pipe for threading

- 1 Open the jaw of the vice and insert the 19 mm dia pipe so that it is horizontal and parallel to the jaw serrations.
- 2 Keep the end of the tube within 150 mm of the vice.
- 3 Close and tighten the vice as shown in Fig 11.

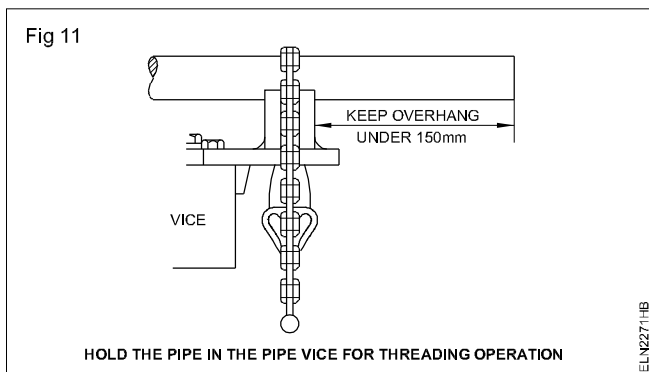

4 File the end of the tube flat and chamfer the outer edge to an angle of about 20° as shown in Fig 12.

Make the depth of the chamfer equal to the pitch of the thread (1.5 mm for conduit).

5 Choose the correct dies and stock suitable for the pipe to be threaded. (Fig 13 shows the conduit stock and dies set)

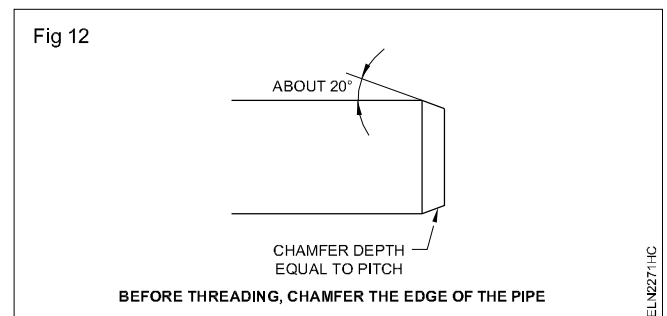

Assembly drawing for the quick cut stock and dies is given in Fig 13. The die size is engraved on the die itself. Check the size with that of the pipe. The handle of the stock is not shown in the picture for clarity.

- 6 Insert each half of the die in the cap(stock) with the chamfered threads (leading faces) being adjacent to the guide.
- 7 Screw the guide into position.
- 8 Adjust each adjusting screw equally to make the die halves centralized to the pipe axis.
- 9 Slide the stock guide over the end of pipe, adjust the adjusting screws such that the dies just grip the pipe evenly on both sides.

Fig 13

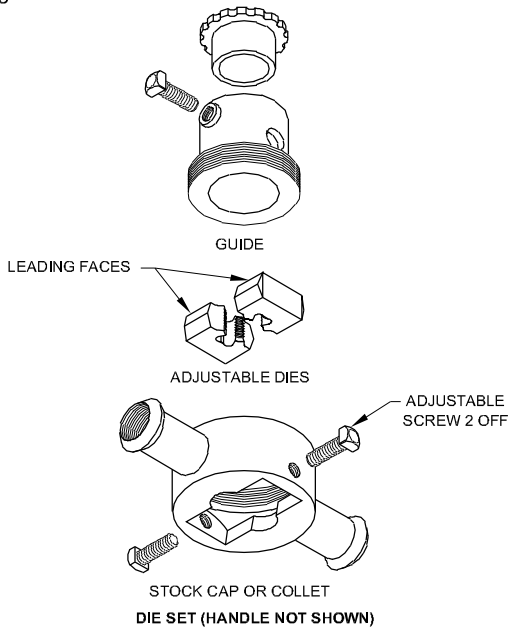

ELN2271HD

10 Apply pressure to the stock and keep the handles at right angles to the pipe as shown in Fig 14.

Fig 14

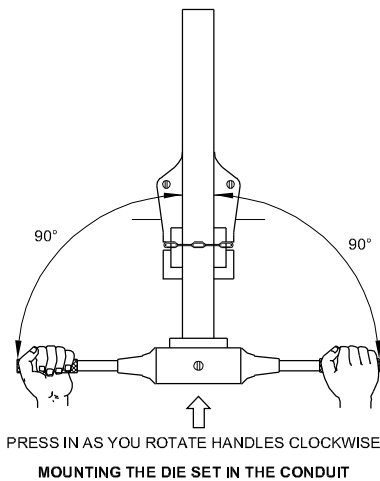

ELN2271HE

11 Rotate the handles clockwise in a plane at right angles to the pipe axis as shown in Fig 15.

Fig 15

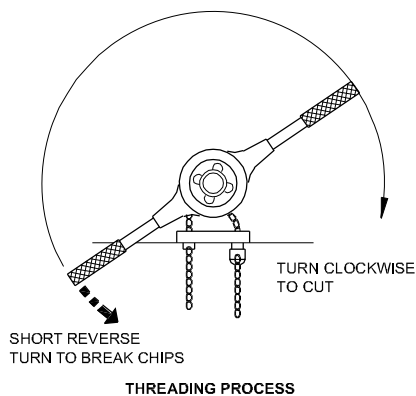

ELN2271HF

12 Apply the lubricant to the part to be threaded after the thread has been started.

The lubricant allows the die to cool off the heat developed and thereby helps the edges to stay sharp and to produce a better thread finish.

13 Make one or two complete turns in a clockwise direction.

Check whether the stock is at right angle to the pipe axis.

14 As indicated by the increased resistance of rotation, ease the handle as frequently as necessary, back in an anticlockwise direction for half a turn.

Reverse turning is necessary to break off long cuttings and to clear the cutting edges of the die.

15 Apply the lubricant at frequent intervals.

Use a brush to remove the metal burrs from the die.

16 Remove the stock. Check the length and fit of the thread by screwing on the female fittings (coupling etc.).

The length of the thread should be sufficient to fit half way into the couplings and fully into the other fittings.

17 If the thread is not smooth (i.e. tight in the fittings) mount the stock and tighten the adjusting screws by half turn evenly and repeat working steps 10 to 16.

18 Remove any burrs or sharp edges from inside the end of the pipe with a reamer or half round file as shown in Fig 16, and file off the sharp edges, if any.

19 Again follow the steps from 2 to 18 in the task-2 for thread the 25 mm dia conduit pipe.

20 Clean the die stock and vice. Keep them in their respective places.

Fig 16

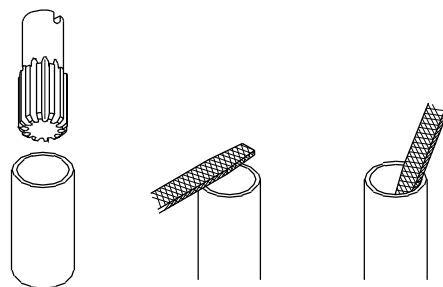

ELN2271HG

TASK 3 : Install and wire up in metal conduit in the lighting circuit for godown

- 1 Form the circuit with the required wiring accessories as per circuit diagram (Fig 17) on the workbench.

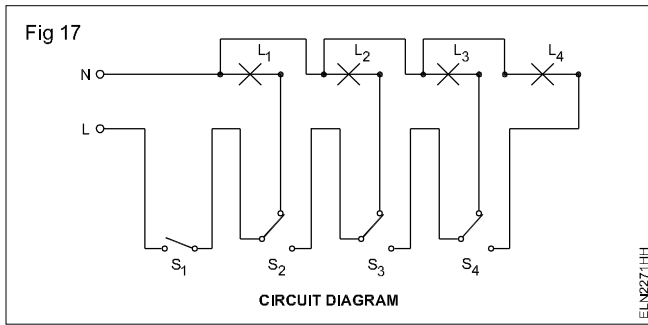

- 2 Get the circuit approved by the instructor.

If it is incorrect, trace the circuit and correct it.

- 3 Mark the layout on I.P.C. (Installation Practice Cubicle) as per the layout given in Fig 18

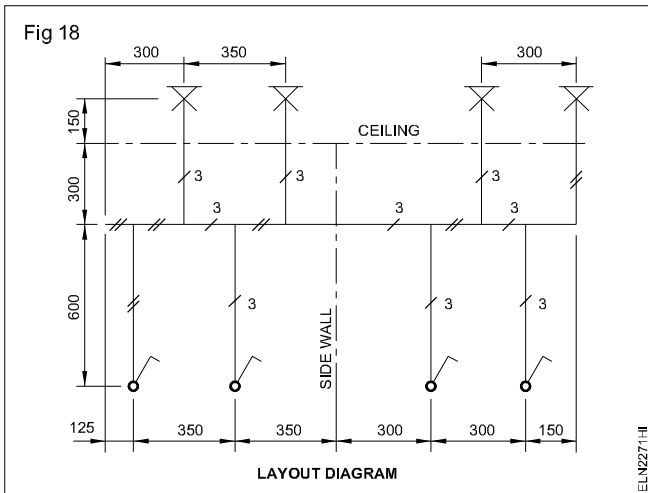

- 4 Select the required conduit fittings as per the layout.
- 5 Measure the length of the conduit pipes required for each run as per the layout.

Take into consideration the length of accessories to be used in various places along with the conduit threads while taking conduit measurements.

- 6 Cut the length of the conduit as per markings and remove the burrs.

While marking on the conduit pipe for cutting, consider the economical way to utilize the pipes without much wastage in the lengths.

- 7 Cut threads in the pipes and remove the burrs.
- 8 Prepare the T.W. spacers with through holes for fixing on the I.P.C. and pilot holes to fix the saddles.
- 9 Fix the T.W. spacers as per the layout.
- 10 Fix the conduit pipe and conduit accessories as per the layout by means of saddles.

Knock out the holes in the square/hexagonal metal boxes for conduit pipe terminations as shown in Fig 19.

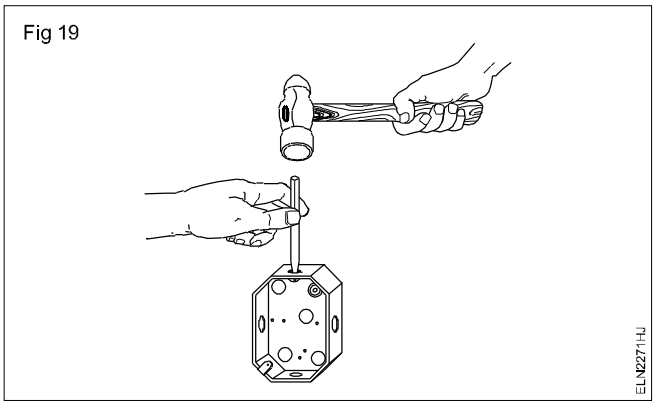

- 11 Measure and cut the cables as per the cable route given in the wiring diagram. (Fig 20)

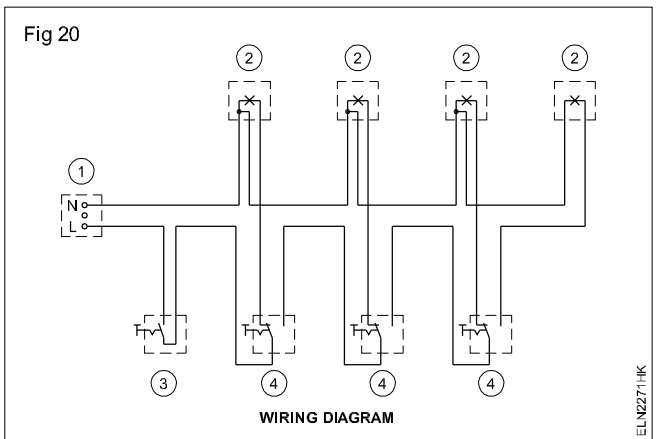

Make an allowance in cable lengths for terminations.

- 12 Provide bushes in the conduit ends.
- 13 Insert the given fish wire in the pipe run for drawing cables.

Drawing of cables should be done stage by stage, taking each run one by one, and consolidating the number of cables in each run.

- 14 Skin the cables and mark each cable legibly at both ends.
- 15 Group the cables as per cable route and cable runs and fasten them to the fish wire as shown in Fig 21.

Check the continuity of cables before fastening the cables to the fish wire.

- 16 Pull the cables by means of the fish wire, and, at the same time push the cables from the other end as shown in Fig 22.

Fig 21

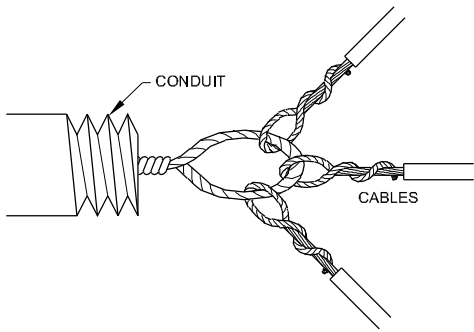

ELN2271:HL

Fig 22

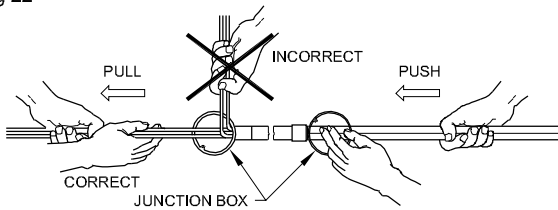

ELN2271:HM

You may require a helper while drawing cables. There should not be any kink or twist in the cables while drawing the cables through the conduit pipe. For long conduit runs, it is better, the drawing of the cables is done in stages, firstly from one end to the inspection type accessory, and then from the inspection type accessory to the end of the conduit, and so on.

17 Prepare top covers of the square metal boxes for fixing the accessories by drilling through holes for cable entry and accessory fixing.

18 Fix the ceiling roses on the one-way junction boxes.

Ceiling roses can be fitted directly on the one-way junction boxes, using the machine screws provided for fixing the cover.

19 Prepare the cable ends and terminate them in the accessories as per Fig 17 and 20, and cable markings done as per step 14.

20 Fix the accessories with machine screws.

21 Close the top covers of the metal boxes.

22 Close the inspection windows of the inspection type accessories.

23 Run the given earth wire along the conduit pipe by means of earth clamps and terminate at the junction boxes and metal boxes. (Fig 24)

It is necessary to follow the looping system to avoid joints in the earth wire runs.

As an alternate to the looping method, the bonding system could be used. Wherever accessories are used, bonding by earth clamps and earth wire as shown in Fig 23 is recommended.

Remove the paint on the surface of the conduit, the copper wire and the clamps before fixing.

Fig 23

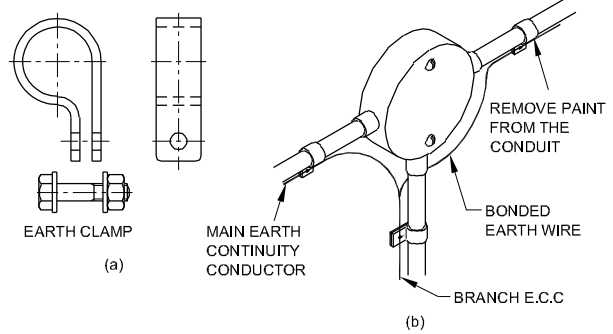

(a)

(b)

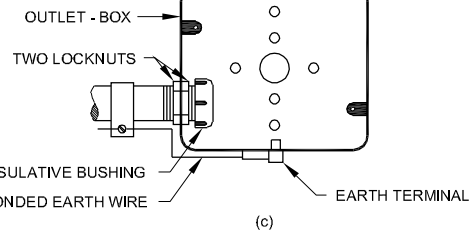

(c)

ELN2271:HM

24 Prepare the pendent-holders and connect the cables to the ceiling roses.

25 Fix the bulbs.

A completed installation looks as shown in Fig 24.

26 Get the wiring checked by the instructor.

27 Connect the supply and test the wiring.

Fig 24

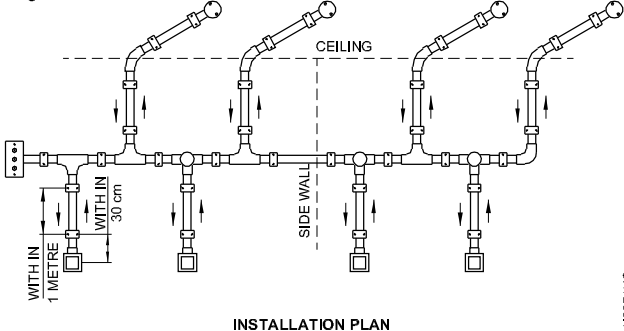

INSTALLATION PLAN

ELN2271:HO

Prepare test boards/extension boards and mount accessories like lamp holders, various switches, sockets, fuses, relays, MCB, ELCB, MCCB Etc.

Objectives: At the end of this exercise you shall be able to

- identify and use Power accessories like double-pole switch and indicating neon lamp
- select the correct size of board to mount specified accessories
- position the accessories and mount them on the T.W. board
- wire up and test the test board. / Extension Board.

Requirements

Tools/Instruments

- Combination pliers 200 mm - 1 No.
- Screwdriver 200 mm with 5 mm blade - 1 No.
- Screwdriver 150 mm with 3 mm blade - 1 No.
- Poker 200 mm - 1 No.
- Firmer chisel 12 mm - 1 No.
- Try square 150 mm - 1 No.
- Tenon-saw 300 mm - 1 No.
- Gimlet 5 mm dia. 200 mm - 1 No.
- Ball peen hammer 250 gms - 1 No.
- 4 mm drill bit - 1 No.
- Connector screwdriver 100 mm - 1 No.
- Hand drilling machine 6 mm capacity - 1 No.
- Mallet 75mm dia. head with handle - 1 No.
- Steel Rule 30 cm - 1 No.
- Key hole saw 200 mm - 1 No.

Materials

- T.W. hinged box 375x250x80 mm - 1 No.
- B.C. batten lamp-holder 6A 250V - 2 Nos.

- Flush mounting 250V 6A 3-pin socket - 3 Nos.
- Flush mounting 250V 6A S.P.T. switch 250V, 6A - 2 Nos.
- PVC copper cable 3/20 - 2 m
- 14 SWG G.I. wire - 1 m
- 12 mm No.5 wood screws - as reqd.
- 20 mm No.6 wood screws - as reqd.
- 25 mm No.6 wood screws - as reqd.
- Neon lamp flush-mounting 250V with holder 6A - 1 No.
- BC bulb 60W, 250V - 1 No.
- Kit-kat fuse-carrier with base flush-type 16A 250V - 1 No.
- Insulated terminals non-detachable 4 mm plug entry - 3 Nos.
- Flush mounting type D.P. switch 250V 20A with neon indicator - 1 No.
- Twin twisted flexible wire 23 / 0.2mm - 5 metre

PROCEDURE

TASK 1 : Prepare the test board / Extension board

- 1 Identify the D.P. switch, its incoming/outgoing terminals and its operation. Identify a neon lamp and its connection.
- 2 Form the circuit as per the schematic diagram Fig 1, using a flexible wire for the testing circuit.

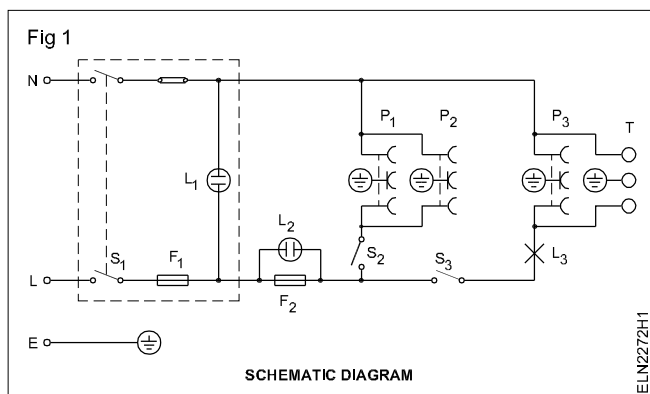

- 3 Get the formed circuit checked by the instructor.

If incorrect, make necessary changes.

- 4 Effect supply and test the circuit.
- 5 Place the accessories on a cardboard to suit the technical and aesthetic aspects and draw a layout. Select the size of the T.W. board accordingly.
- 6 Compare the layout drawn by you with the layout given in Fig 2 and discuss with your co-trainees about their merits and de-merits.
- 7 Mark the position of the double-pole switch and other accessories on the T.W. board as per the given layout (Fig 2) and the supplied drawing of the front panel. (Fig 3)
- 8 Cut profiles for fixing the accessories to the T.W. board and drill holes for cable entries, insulated terminals and fixing screws, and make pilot holes wherever necessary.

Fig 2

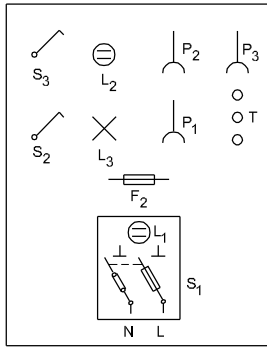

TEST BOARD-LAYOUT DIAGRAM

ELN2272H2

Use the B.I.S. recommended colour code for cable connections within the test board.

- 12 Route the connecting cables between accessories neatly, harness (strap - bunch) the cables.
- 13 Connect the accessories and the insulated terminals after identifying phase and neutral.
- 14 Connect the earth wire with earthing terminals of socket outlets, one of insulated terminals and the double pole switch. A completed test board will look as shown in Fig 4.

Fig 3

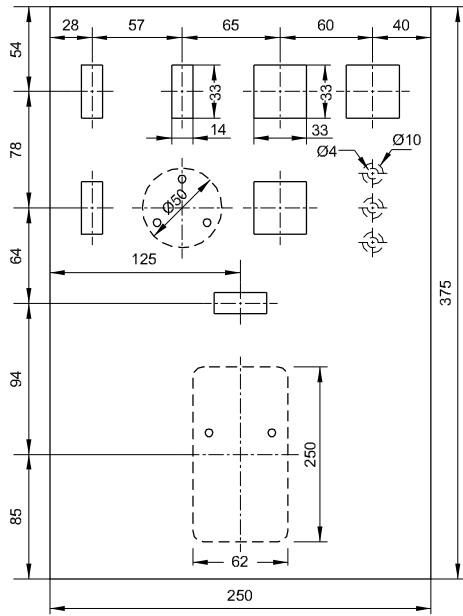

TEST BOARD FRONT PANEL DRAWING SHOWING THE PROFILE

ELN2272H3

Fig 4

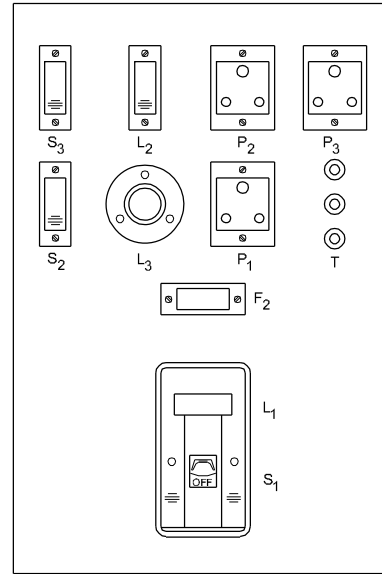

FRONT PANEL VIEW OF THE TEST BOARD

ELN2272H4

- 15 Provide bulbs in the lamp-holders.
- 16 Get the approval from your instructor and test the test board.

- 9 Fix the Power accessories on the T.W. board.
- 10 Fix three numbers of insulated terminals.
- 11 Measure and cut cables for harnessing, according to the circuit diagram. (Fig 1)

Draw layouts and practice in PVC casing - capping, conduit wiring with minimum to more number of points of minimum 15 metre length

Objectives: At the end of this exercise you shall be able to

- mark the layout on the work station/location
- prepare PVC channel as per the marked layout
- fix the PVC channel and other PVC accessories
- run the cable as per the circuit diagram
- fix the top cover on the casing
- prepare & fix the PVC boxes
- mount the switches, fan regulator, socket on the switch board
- connect the end terminals to load as per the circuit diagram & test it.

Requirements

Tools and Instruments

- Electrician tool kit - 1 No.
- Hacksaw frame with blade - 1 No.
- Rawl jumper No.14 - 1 No.
- Screw driver 100mm - 1 No.
- Steel tape 5 m - 1 No.
- Steel Rule 300mm - 1 No.
- Electric/Hand drilling machine (capacity 6mm) - 1 No.
- Twist drill bit 5mm - 1 No.

Material required

- PVC casing and capping 25mm x 10 mm - 20mtrs
- PVC round block - 90 mm x 40 mm - 3 Nos.
- T.W. box 250 mm x 100 mm with Sunmica cover - 1 No.
- Terminal plate 16 Amps - 3 way - 1 No.

- Single pole one way switch-6A,230V Flush type - 4 Nos.
- Electronic fan regulator - socket type - 1 No.
- 3 Pin socket - 6A 250V Flush type - 1 No.
- Batten lamp holder - 6A, 250V - 2 Nos.
- Ceilling rose 6A, 250V - 1 No.
- PVC insulated aluminium cable 1.5 sq. mm - 100 mtr.
- Wood Screw No. 6 X12 mm - 20 Nos.
- Wood Screw No.6 X 20 mm - 7 Nos.
- PVC Casing and capping Elbow -25 mm - 1 No.
- PVC casing and capping Tee (3 way) - 2 Nos.
- PVC Casing and capping internal coupler - 3 Nos.
- Colour chalk / pencil - 1 No.
- PVC insulation tape roll 20mm - 1 Roll

PROCEDURE

- 1 Analyze the layout diagram Fig 1 showing the location of fittings, accessories and their distances.
- 2 Draw the wiring diagram for the given circuit as per layout plan. Check the correctness of the wiring diagram with the help of Fig 1 (supplied by the instructor).
- 3 List out the materials required for this wiring along with complete specifications and quantity required for this wiring.
- 4 Check your material list with that of supplied list.

Hand over the list to the instructor for checking and get the approval.

- 5 Collect the materials as per the list.
- 6 Mark the layout as per the work station/location. Cut and prepare the casing as per the installation plan diagram.

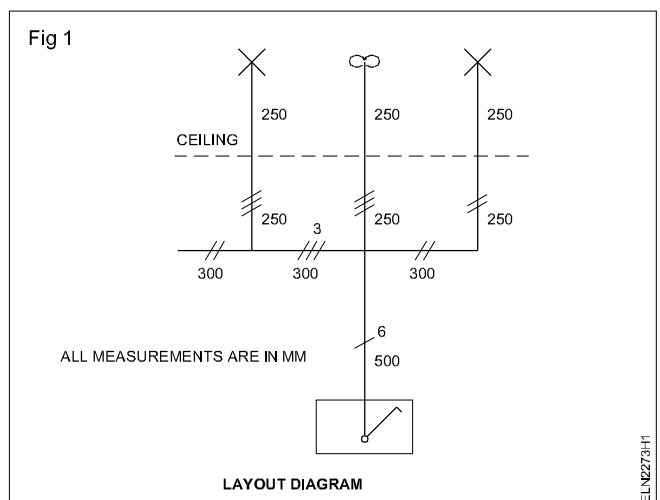

- 7 Drill holes in the PVC channel for fixing with a gap of 60cm using drilling machine.

- 8 Place the PVC channel in the route mark coinciding with the jumper holes for fixing.
- 9 Prepare the joints on PVC channel (refer layout).
- 10 Fix the PVC channel on the work station as per the layout.
- 11 Run the cable into the PVC channel as per wiring diagrams (Fig 2)
- 12 Fix the cover on the channel.
- 13 Mark and cut the PVC boxes for the channel entries.
- 14 Drill holes for cable entry and take out cables as per installation plan.
- 15 Terminate the cable in accessories and mount the switches, regulator & socket over the switch box.
- 16 Test the circuit for insulation resistance, continuity test & polarity.

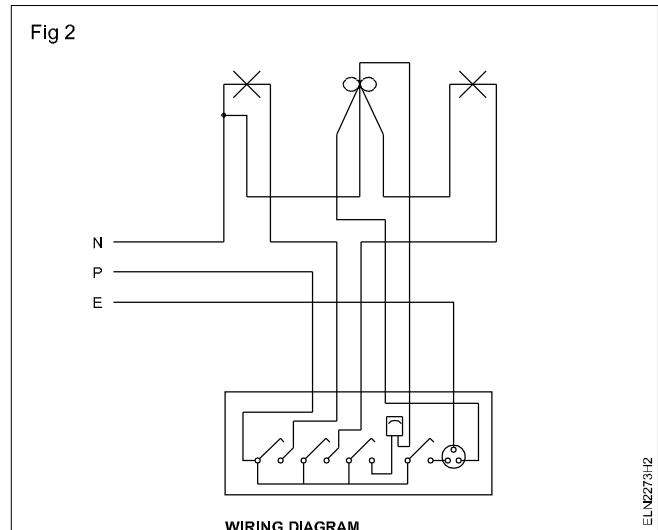

Only after obtaining satisfactory results of the above test, circuit to be energised.

- 17 Connect the circuit with supply and test it.

Wire up PVC Conduit wiring to control one lamp from two different places

Objectives: At the end of this exercise you shall be able to

- form the circuit using two-way switches to control one lamp from two different places
- cut the profiles in a wooden board according to marking for flush-type accessories
- wire up a circuit in PVC conduit pipe to control one lamp from two different places.

Requirements	
Tools/Instruments	
<ul style="list-style-type: none"> • Cross Peen hammer 250 gms - 1 No. • Insulated screwdriver 200 mm width 5 mm blade - 1 No. • Insulated screwdriver 150 mm width 5 mm blade - 1 No. • Electrician's knife (100 mm) - 1 No. • Connector screwdriver 100 mm - 1 No. • Mallet 5 cm dia. -500 gram - 1 No. • Gimlet 5 mm dia. 200 mm long - 1 No. • Hand drilling machine 6 mm capacity - 1 No. • Drill bit 3 mm to 5 mm - 1 each • Try square 150 mm - 1 No. • Bradawl 150 mm - 1 No. • Insulated combination pliers 200 mm - 1 No. • Hacksaw frame with blade (24 TPI) - 1 No. • Steel rule (300 mm) - 1 No. 	<ul style="list-style-type: none"> • PVC terminal box - 1 No. • Wood screws No.6x12 mm - 3 Nos. • Wood screws No.6x20 mm - 4 Nos. • PVC--Insulated aluminium cable 1.5 sq mm. 250V grade - 6 m • Flush mounting two-way switch 6A, 250V - 2 Nos. • Batten lamp-holder, 6A, 250V - 1 No. • Terminal plate 3-way - 1 No. • Bulb 40W, 250V, BC type - 1 No. • PVC round block (90mm x 40 mm) - 1 No. • PVC box 100 mm x 100 mm - 2 No. • PVC 'Tee' 19 mm - 2 Nos. • Marking Pen/Pencil/Chalk - as reqd. • Marking thread - as reqd. • PVC Insulation tape - 1 Roll • Self tapping screw (20 mm) - as reqd. • PVC bend 19mm - 2 mtrs
Materials	
<ul style="list-style-type: none"> • PVC conduit pipe -19 mm dia. - 2 mtrs 	

PROCEDURE

- 1 Estimate the tools and materials required for the job according to the layout (Fig 1) and the wiring diagram. (Fig 3) Compare the list with the given list. Discuss with your co-trainees/instructor about the variations between the two lists.

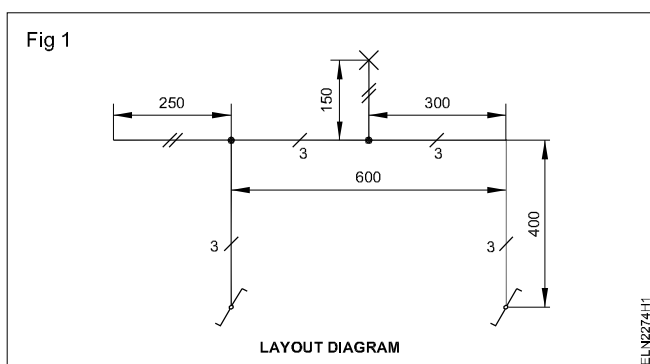

- 2 Collect materials as per the list.
- 3 Identify and confirm the switches received are two-way switches only.
- 4 Identify the terminal points, cable entry holes and fixing holes of the switches and batten lamp-holders.

- 5 Form the circuit as per the schematic diagram shown in Fig 2.

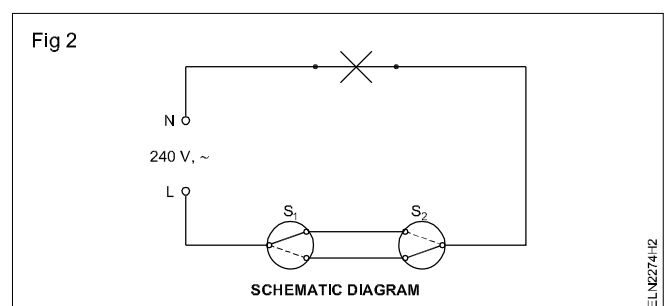

Get the approval of the instructor. If necessary, make alterations in the connections.

- 6 Connect the supply, check the function of the circuit and note the results in Table 1.

TABLE 1

S ₁ , S ₂ position up	_____
S ₁ , S ₂ position down	_____
S ₁ up and S ₂ down	_____
S ₁ down and S ₂ up	_____

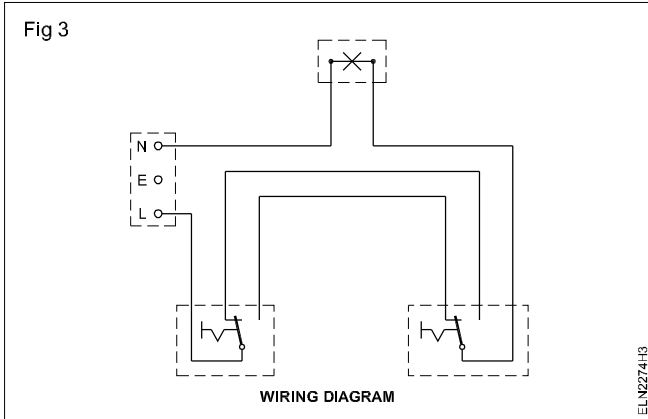

7 Mark the layout points on the building as per the installation plan (Fig 4)

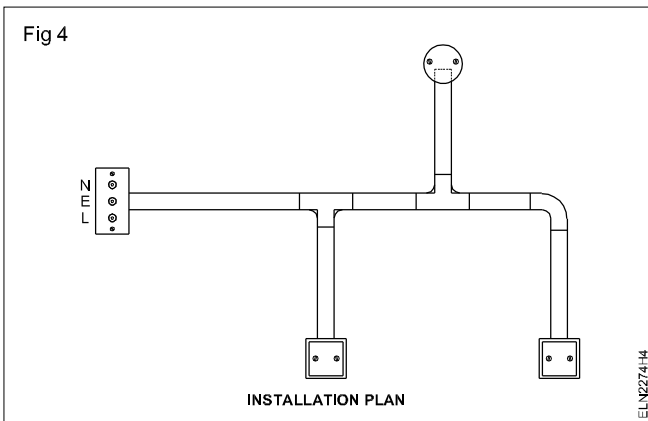

8 Cut the required length of PVC pipes as per the layout marking.

Take into consideration the length of bends, tees and corners in appropriate places to reduce the measured length of the P V C conduits.

9 Mark the position of the saddles on the building and fix them loosely on one side only.

Observe the N.E. Code for the distance between saddles. In the case of brick/concrete walls, the wooden plugs (gutties) are to be fixed flush with the walls, cemented and cured.

10 Fix the PVC pipe and accessories in the saddle and tighten the saddle screws. Cut the cables according to the wiring diagram (Fig 2)

Keep an extra 200 to 300 mm for termination

11 Insert the cables in the pipes and fittings and push / draw the cables to the other end of the pipes according to the wiring diagram (Fig 3)

For longer lengths of PVC conduit runs, use fish wire/curtain spring to pull the cables through the conduits.

12 Mark the entry profile of the conduit in the round block and boxes. Based on the conduit entry position, position the accessories on the round block, mark the through holes for cable entry, and the pilot holes for fixing the accessories.

13 Prepare the conduit entry profile, drill/make through and pilot holes in the round block and boxes.

14 Insert the cables through the cable entry holes of the round blocks and boxes and fix the round block and boxes on the building.

15 Connect the cable ends to the accessories according to the wiring diagram and fix the accessories on round blocks and boxes.

The completed installation should look as per the installation plan shown in Fig 4

16 Test the circuit after getting the approval of the instructor.

Wire up PVC conduit wiring to control one lamp from 3 different places

Objectives: At the end of this exercise you shall be able to

- verify and draw the I.M. switch connections in alternate positions of the knob
- draw a schematic diagram to show one lamp being controlled from 3 different places based on the I.M. switch connections
- form the given circuit with the I.M. switch.
- cut and lay the PVC pipes as per dimensions with the required number of bends, elbows and different types of junction boxes in the ceiling and the wall
- draw the cables through pipe according to the wiring diagram
- fix the accessories on boards and terminate the cables in accessories .
- test the circuit.

Requirements

Tools/Instruments

- Hacksaw frame 300mm with 24 TPI blade - 1 No.
- Steel tape roll 5 Meter - 1 No.
- Insulated Screwdriver 250mm with 4mm blade width - 1 No.
- Insulated Screwdriver 150mm with 3mm blade width - 1 No.
- Insulated Connector screw driver 100mm with 3mm blade width - 1 No.
- Plumb bob with thread - 1 No.
- Try square 250mm - 1 No.
- Ball peen hammer 250 grams - 1 No.
- Poker 4mm dia. 200mm - 1 No.
- Gimlet 4 mm dia. 200mm - 1 No.
- Electrician's D.B knife 100 mm - 1 No.
- Cutting pliers, insulated 200mm - 1 No.
- Hand drilling machine, 6mm capacity - 1 No.
- S.S. drill bit 3mm and 4mm - 1 each
- Side cutting pliers 150mm - 1 No.
- Firmer chisel 12 mm - 1 No.

Materials

- PVC pipe 20mm dia. - 4 mtrs
- PVC bend 20mm dia. - 2 Nos.
- PVC elbow 20mm dia. - 1 No.
- PVC Tee 20mm dia. - 3 Nos.
- Saddles 20mm dia. heavy gauge - 10 Nos.
- Wood screws No.6 12mm - 40 Nos.
- Wood screws No.6 18mm - 8 Nos.
- PVC cable 1.5 sq.mm 250V grade - 15 m
- T.W. round blocks with box 90 x 40mm - 4 Nos.
- Terminal plate 3-way - 1 No.
- S.P.switch 2-way Flush type 6A 250V - 2 Nos.
- Intermediate switch 6A 250V - 1 No.
- Bakelite batten-holder of B.C. type 6A 250V - 1 No.
- B.C. lamp 40W 250V - 1 No.

PROCEDURE

TASK 1 : Ascertain the connections of an intermediate switch

- 1 Collect the accessories and materials for the exercise.
- 2 Identify the mode of connections to the terminals with respect to the position of the knob and draw the connection diagram in your record book.
- 3 Keeping the above connections as the base, draw a schematic diagram to control one lamp from three different places, in your record book.
- 4 Compare the schematic drawn by you with the schematic diagram given in Fig 1.
- 5 Show the connections to your instructor and get his approval.

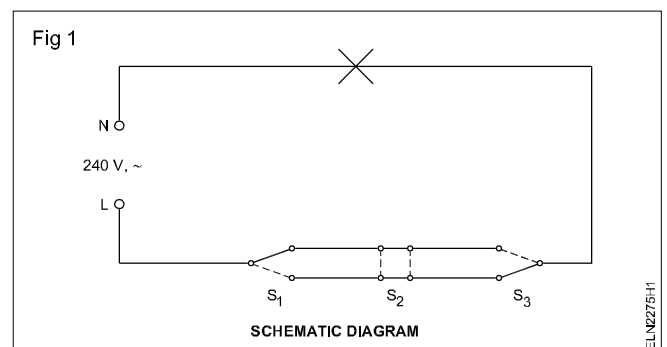

TASK 2 : Form the circuit on the workbench/trainer board

- 1 Form the circuit according to the approved diagram on the workbench/trainer board.
- 2 Show the circuit to the instructor and get his approval.
- 3 Operate the switches as given in Table 1 and note down the results in Table 1.

Table 1

Position of S ₁ knob	Position of S ₂ knob	Position of S ₃ knob	Condition of lamp
↑	↑	↑	ON/OFF
↓	↑	↑	
↓	↓	↑	
↓	↓	↓	
↑	↓	↓	
↑	↑	↓	
↓	↑	↑	
↓	↑	↓	

TASK 3 : Execute PVC conduit wiring

- 1 Mark the layout on the installation practice cubicle as per the layout given in Fig 2.

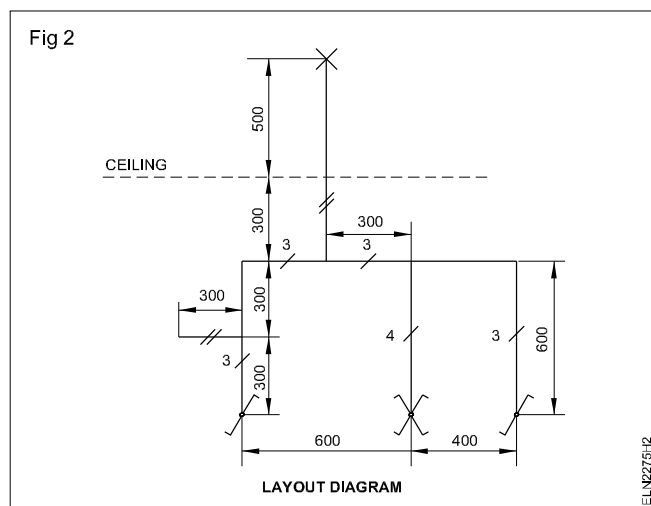

- 2 Cut the required length of P V C pipes as per the layout marking.

Take into consideration the length of bends, tees and corners in appropriate places to reduce the measured length of the P V C conduits.

- 3 Mark the position of the saddles in the I.P.C. and fix them loosely on one side only.

Observe the N.E. Code for the distance between saddles. In the case of brick/concrete walls, the wooden plugs (gutties) are to be fixed flush with the walls, cemented and cured.

- 4 Fix the PVC pipe and accessories in the saddle and tighten the saddle screws.
- 5 Cut the cables according to the wiring diagram. (Fig 3)

Keep an extra 200 to 300mm for termination.

- 6 Insert the cables in the pipes and fittings and push/draw the cables to the other end of the pipes according to the wiring diagram. (Fig 3)

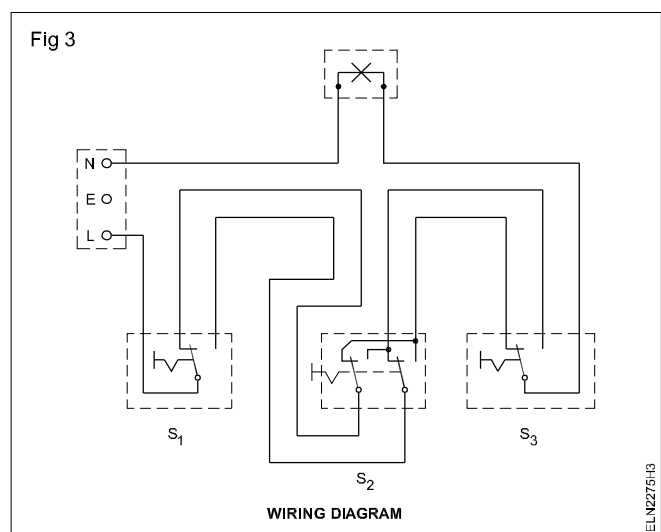

For longer lengths of P V C conduit runs, use fish wire/curtain spring to pull the cables through the conduits.

- 7 Mark the entry profile of the conduit in the round block.
- 8 Based on the conduit entry position, position the accessories on the round block, mark the through holes for cable entry, and the pilot holes for fixing the accessories.
- 9 Prepare the conduit entry profile, drill/make through and pilot holes in the round block.
- 10 Insert the cables through the cable entry holes of the round blocks and fix the round block on boards.
- 11 Connect the cable ends to the accessories according to the wiring diagram and fix the accessories on the T.W. round blocks.

The completed installation should look as per the installation plan shown in Fig 4.

- 12 Test the circuit after getting the approval of the instructor.

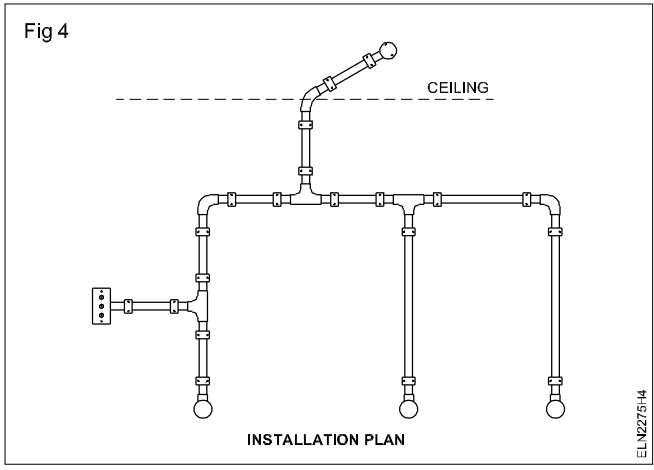

Wire up PVC Conduit wiring and practice control of sockets and lamps indifferent combinations using switching concepts

Objectives: At the end of this exercise you shall be able to

- determine the size of the cable for power wiring
- cut non-metallic conduit pipes
- fix the accessories to the pipes according to the pipe size with the tight grip method
- fix conduit with the necessary clamps and spacers on surface installation in accordance with I.S. recommendations
- draw wires with non-metallic conduit pipes
- wire up the power circuits in P.V.C. conduit
- test the circuit.

Requirements	
<p>Tools/Instruments</p> <ul style="list-style-type: none"> • Insulated combination pliers 200mm - 1 No. • Insulated screwdriver 200mm width 4mm blade - 1 No. • Insulated side cutting pliers 150mm - 1 No. • Electrician's knife 100 mm - 1 No. • Bradawl 150mm - 1 No. • Ball peen hammer 250 grams - 1 No. • Hacksaw with 24 TPI blade - 1 No. • Firmer chisel 6mm x 200mm - 1 No. • File rasp half round 200 mm basted with handle. - 1 No. • Flat file rasp 200mm - 1 No. • Neon tester 500V - 1 No. • Drill bits 6mm, 3mm each - 1 No. • Hand drilling machine 6mm capacity - 1 No. 	<p>Materials</p> <ul style="list-style-type: none"> • PVC pipe 20 mm dia. - 11 mts • 3-way junction box 25 mm - 3 Nos. • 20mm sadles - 19 Nos. • TW Box 200 x 150 x 40mm - 4 Nos. • PVC sheathed aluminium cable 4 sq mm. 250 V - 52 mts • Copper wire 14 SWG - 13 mts • SPT switch 16A 250V - 2 Nos. • 3-pin socket 16A 250V - 2 Nos. • 3-pin socket with switch 16A 250V - 2 Nos. • T.W. wooden spacers - 20 Nos. • Terminal plate 16 A 6-way - 1 No. • Wood screws No. 6 x 25 mm - 20 Nos. • Wood screws No. 6 x 12 mm - 40 Nos. • PVC elbow 20 mm - 1 No. • Surface-mounting type Kit-kat fuse 16A, 250V - 2 Nos.

PROCEDURE

TASK 1: Determine the size of cable for power wiring

- 1 Ascertain the load particulars of each socket, assuming each socket is feeding one room air-conditioner of 1.5 ton capacity.

Refer to I.E. regulations, NE code and I.S. recommendations regarding socket connections, loading and maximum number of sockets per circuit.

- 2 Determine the number of circuits, the size of cables for the circuit and branch circuits.

Refer to the table of current-carrying capacity of cables.

- 3 Fill in Table 1 and get the approval of the instructor for the results.

Table 1

Name-plate details of the air-conditioner	Capacity : 1.5 ton Voltage : 230 V 50 Hz Current : 13 A
Load on each socket amps
Number of permitted sockets in one circuit sockets
Number of circuits required for the given task circuits
Current in the main circuit cable when four air-conditioners are working amps
Current in the branch circuit Cable when both the air-conditioners are working amps
Cable selected for the main circuit	Area of cross-section: sq. mm Size : mm Volts grade : volts
Cable selected for the branch circuit	Area of cross-section: sq. mm Size : mm Volts grade : volts



TASK 2 : Form the circuit and test it

- 1 Form the circuit on the workbench/trainer board with the required accessories as per schematic diagram. (Fig 1)
- 2 Get the approval from your instructor.
- 3 Effect supply and test the circuit.

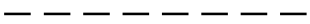
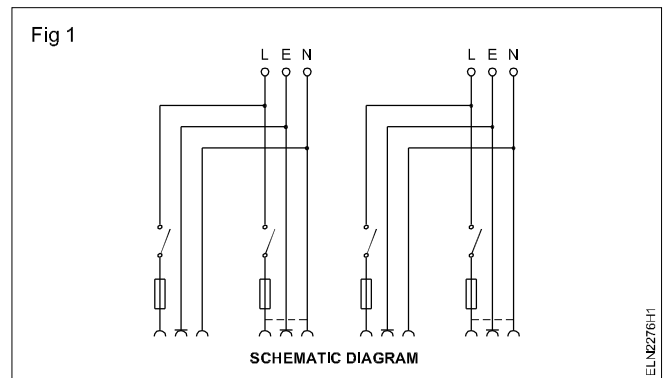

TASK 3 : Wire the power circuit with P V C conduit

- 1 Mark the layout on I.P.C. as per the layout diagram. (Fig 2)
- 2 Cut the PVC conduit according to the layout by taking the length of the fittings into consideration.
- 3 Fix the wooden spacer on the layout marking as per installation plan shown in Fig 3, with the help of 25mm wood screws.
- 4 Fix the saddles on one side only on the wooden spacers.
- 5 Cut the cable length according to the route length taking into consideration the layout diagram, Fig 2 and the wiring diagram, Fig 4.

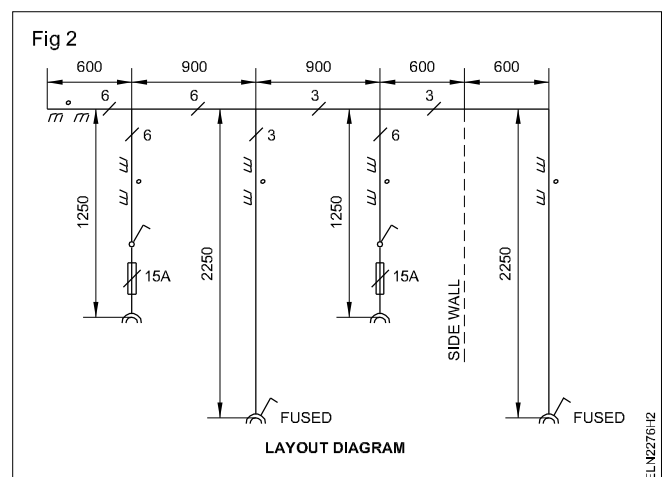

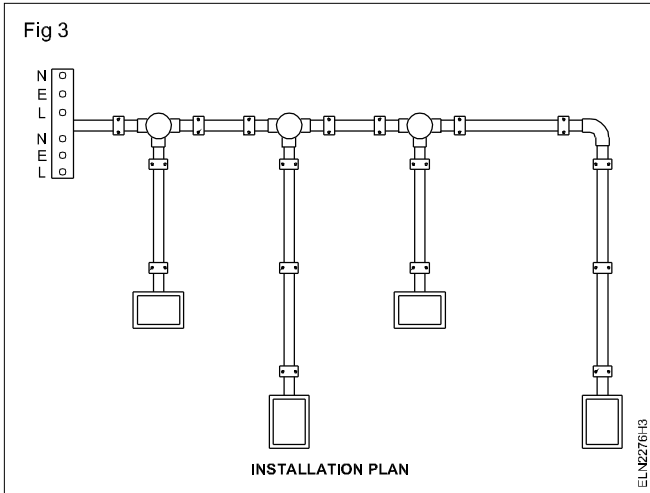

Keep an extra length of 200 to 300 mm in each cable run.

- 6 Fix the PVC conduits and accessories in the saddles and tighten the saddles by means of wood screws.
- 7 Insert the cables and the earth wire in the pipe and fittings, and push the wires to the other end of the pipe.
- 8 Prepare wooden boxes for conduit terminations, for fixing accessories and for taking cable terminations.
- 9 Fix the base of the boxes on the I.P.C. and fix the cover on the boxes after inserting the cables in the respective holes.

Expansion of the acronym I.P.C. is Installation Practice Cubicle/Wiring cabin/Wiring booth.

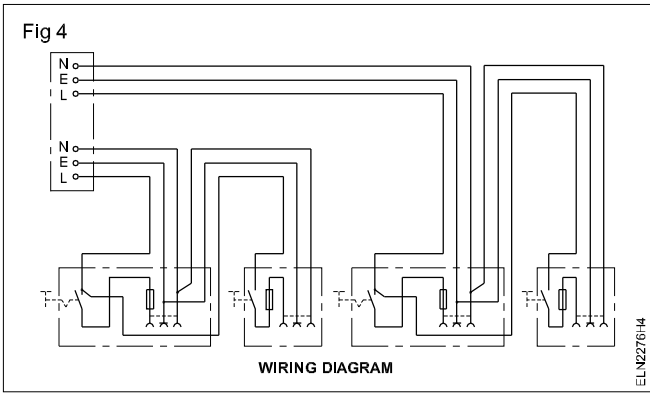

- 10 Connect the cable ends to the accessories and fix the accessories to the boxes with screws.
- 11 Connect the earth wire. (The completed installation should look as shown in Fig 3.)

The minimum size of earth wire, 14 SWG, tinned copper must be used.

- 12 Get the approval of the instructor.

Wire up the consumer's main board with I.C.D.P. switch and distribution fuse box

Objectives: At the end of this exercise you shall be able to

- place the I.C.D.P switch and distribution fuse box on the board as per the given layout observing the standard code of practice
- mark on the board to drill holes for the purpose of drawing wires and for fixing the accessories
- drill suitable holes to fix accessories and for cable entry
- fix the accessories
- identify and earth the metal parts
- identify the cable to be connected for phase and neutral according to the colour of insulation
- select and confirm the size of the cables according to the capacity of the main switch and D.B.

Requirements	
Tools/Instruments	
• Steel rule 300mm	- 1 No.
• Insulated Side cutter 150mm	- 1 No.
• Combination pliers 200mm	- 1 No.
• Hand drilling machine 6mm capacity with 3mm,6mm bits	- 1 Set
• Poker 200mm	- 1 No.
• Insulated Screwdriver 200mm with 4mm blade	- 1 No.
• Insulated Screwdriver 150mm with 3mm blade	- 1 No.
• Connector screwdriver 100mm	- 1 No.
• Neon tester 500V	- 1 No.
• Wooden mallet 7.5cm dia.500 g	- 1 No.
• Electrician's knife DB 100 mm	- 1 No.
• Tenon-saw 300mm	- 1 No.
• Gimlet 200mm with 4mm dia. stem	- 1 No.
• Firmer chisel 12mm	- 1 No.
• Wood rasp file 200mm flat	- 1 No.
Material	
• Iron-clad double pole switch 16A 250V	- 1 No.
• Distribution fuse box 4-way 16A 250V	- 1 No.
• Wood screws No. 25 x 6 mm	- 4 Nos.
• Wood screws No. 20 x 6 mm	- 4 Nos.
• Wood screws No. 15 x 6 mm	- 2 Nos.
• PVC aluminium cable 2.5 sq mm in red and black colour	- 1.5 m each.
• Tinned copper wire 14 SWG	- 3 m
• T.W. hinged box 300 x 250 x 80 mm	- 1 No.
• 3mm dia. 25 mm long full-threaded G.I bolt, nut and washer	- 10 Nos.
• PVC Cable clips 10 mm wide 2 mm thick	- 300 mm

PROCEDURE

- 1 Mark the position of the given ICDP and DB on the top surface of the T.W. board as shown in Figs 1 and 2.

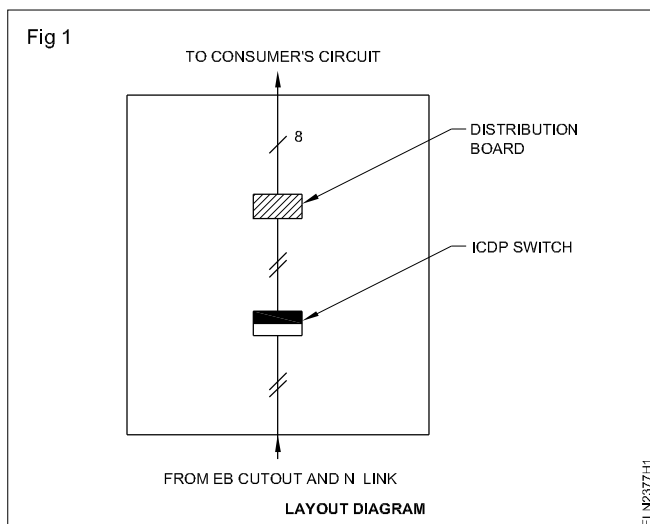

- 2 Mark the position of through holes for cable runs and earth conductor.

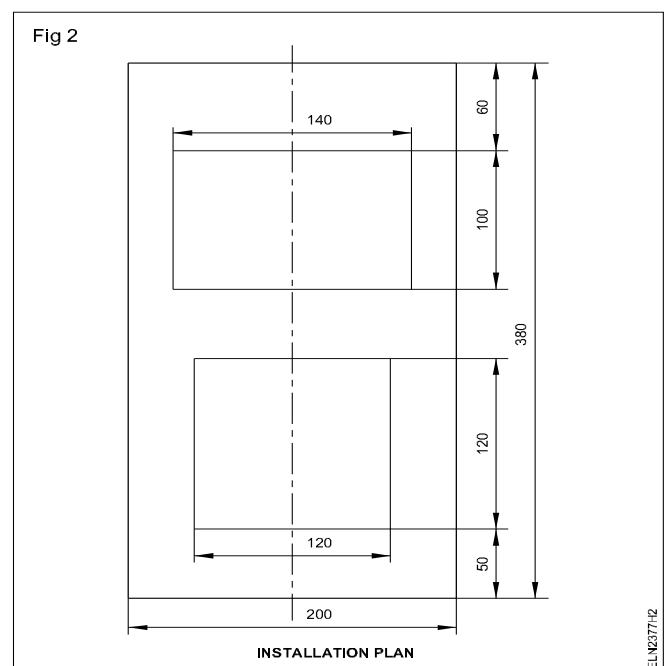

- 3 Drill suitable holes (either pilot or through) in the T.W. board to fix ICDP and DB.
- 4 Drill holes for cable entry.
- 5 Provide holes in the top and bottom of the base T.W. board for the supply and outgoing cables.
- 6 Fix ICDP and DB using wood screws/other fasteners.
- 7 Select and confirm the size of the cables according to the ratings of the main switch and DB.
- 8 Connect the supply leads to the ICDP through the T.W. board. Mark the end of the phase cable.

While connecting the incoming and outgoing cables to the I.C.D.P. and D.B. they should pass through the holes in the top board and then through the holes provided in the top and bottom sides of the base board.

In both cases sufficient allowance of length should be given in the cables such that the hinged top board could be opened at an angle of 120° from the base board. Harnessing of the cables inside the board should be done with the P.V.C. cable clips, and the cables should pass in or out from the I.C.D.P. and D.B. through the P.V.C. bushed holes.

- 9 Interconnect the ICDP and DB as shown in Fig 4. Provide 4 pairs of outgoing cables from the D.B. for four branch circuits. Compare the wiring diagram (Fig 4) with the Circuit diagram (Fig 3).

While using connecting cables observe the colour code. Phase:red, Neutral:black.

- 10 Locate the earth connecting points on the ICDP and DB and drill suitable holes for the earthing leads in the T.W. board.
- 11 Connect the earth wire to the DB and ICDP, and then connect the E.C.C. to the meter board earth plate.
- 12 Fix the fuses in the DB and main switch according to the circuit/main loads.

Individual circuit loads have to be indicated in amperes by fixing labels on the D.B

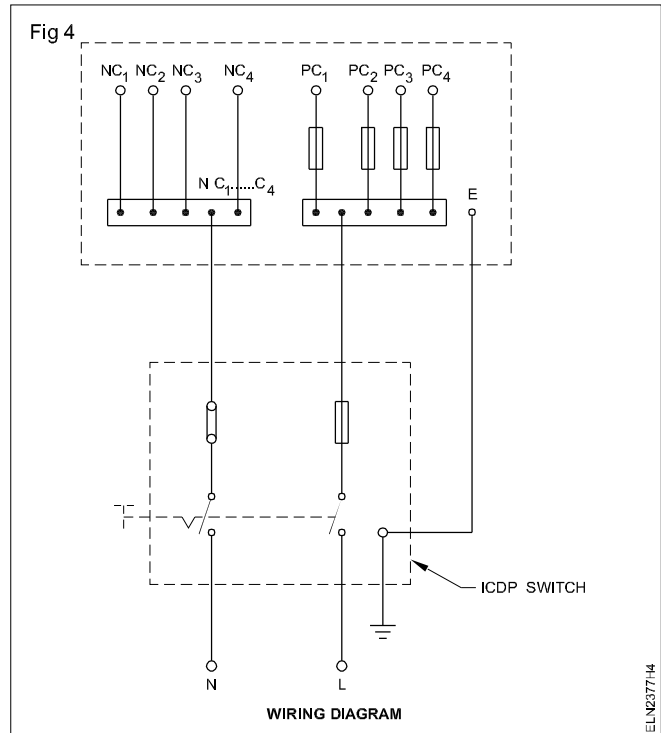
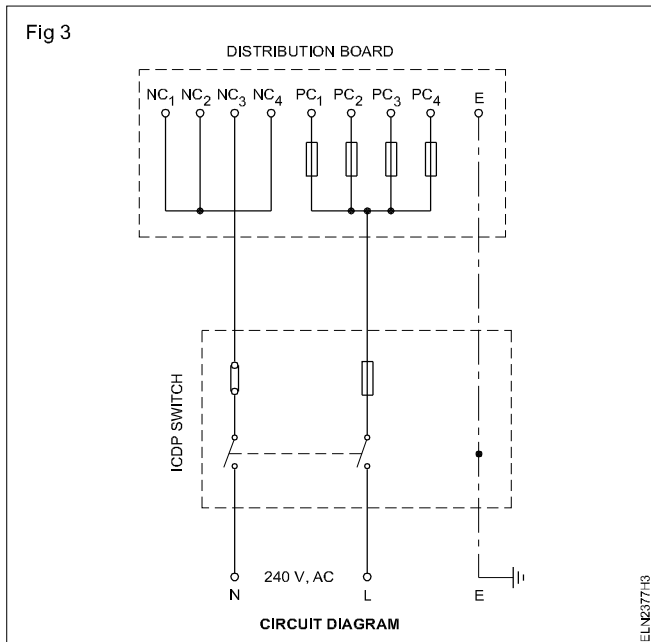

Prepare and mount the energy meter board

Objectives: At the end of this exercise you shall be able to

- make holes on the wall according to requirement with a rawl jumper and hammer
- fill the holes with filling material
- make recess holes for fixing wooden gutties
- fix wooden gutties (wooden plugs) in the wall
- use a pipe jumper for making holes through the masonry wall
- mount the given energy meter, iron-clad cut out and the neutral links on the meter board
- connect the meter, iron-clad cut out and the neutral link as per regulations
- mount the meter board on the wall.

Requirements

Tools/Instruments

- Insulated Steel rule 300mm - 1 No.
- Insulated Side cutter 150mm - 1 No.
- Combination pliers 200mm - 1 No.
- Hand drilling machine with 3mm and 6mm drills - 1 No.
- Insulated Screwdriver 200mm with 4mm blade - 1 No.
- Insulated Connector screwdriver 100mm - 1 No.
- Poker 200mm long with 4mm dia. stem - 1 No.
- Electrician's knife DB 100 mm - 1 No.
- Firmer chisel 12mm wooden handle - 1 No.
- Rawl jumper No.8 with holder and bit - 1 No.
- Cold chisel 200mm long with 12mm edge - 1 No.
- Ball peen hammer 500 gm. - 1 No.
- Tenon-saw 250mm - 1 No.
- Mallet with 7.5cm dia. head 500 gm - 1 No.
- Neon tester 500 V - 1 No.
- Scriber 200mm with 3mm dia. stem - 1 No.
- Mason's trowel - 1 No.
- Tray for cement mortar - 1 No.

Equipment Machines

- Single phase energy meter 10/15A 250V

Materials

- PVC insulated copper cable 2.5 square mm - 3 m
- Tinned copper wire 14 SWG - 1 m
- Iron-clad cut out 16A - 1 No.
- Neutral link 16A - 1 No.
- T.W. board 250x250x40mm - 1 No.
- Porcelain spacers - 4 Nos.
- Teak wood gutties (wooden plugs) 40mm square x 60mm long x 30mm square - 4 Nos.
- Wood screws No.4 x 25 mm - 3 Nos.
- Cement - 1/2 kg.
- River sand - 2 kgs
- Rawl plug No.8 - 4 Nos
- Rawl plug Compound - 25 gms.
- Chalk piece (colour) - 1 No.
- G.I. pipe 20mm - 400 mm.
- Wood screws No. 50 x 8 mm - 4 Nos.

TASK 1 : Preparation of wall for mounting meter board

Method 1 (Rawl plug)

If the masonry wall is of a rigid type, follow this method.

- 1 Drill four numbers of through holes of 3mm dia. in the T.W. board as shown in Fig 1.
- 2 After ascertaining the height of the meter board position with respect to the ground, keep the T.W. board on the wall and mark the position of the holes of the board on the wall with a scribe.

Take care to keep the board in a correct horizontal/vertical position on the wall.

- 3 Select a No.8 rawl bit with the jumper handle.
- 4 Keep the rawl bit of the jumper on the mark and hammer it lightly to mark the position of the holes.

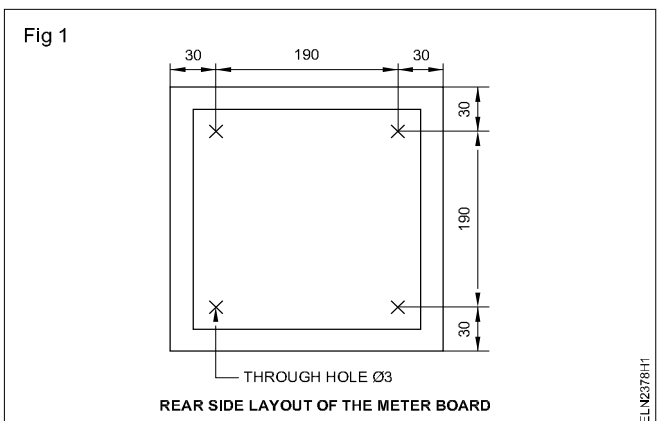

First make a slight impression with a rawl jumper on all the four markings and verify their correctness with the holes in the board.

- Keeping the rawl jumper on one of the markings, hammer and rotate the jumper handle by 90° for each stroke of hammer.

This will enable the broken pieces of mortar to come out without gripping the rawl bit. Otherwise the bit will not come out easily at the end of the operation or the bit may even break.

- Make a hole to a depth of 40mm.
- Repeat this method in the other three markings.
- Dip the rawl plugs in water, plug them in the holes and slightly hammer on them to make them flush with the wall.

Now the wall is ready for mounting the T.W. board.

- Fix the board on the wall with 45mm long wood screws.

You may use rawl powder compound (asbestos based) in the place of rawl plugs. In this case the powder needs to be mixed with water to make a semi-solid paste before filling it into the holes tightly.

Method 2 Wooden gutties (Plug)

If the wall is not too rigid, follow this method.

- Repeat working steps 1 and 2 of Method 1.
- Mark 50mm square around the marking as shown in Fig 2.

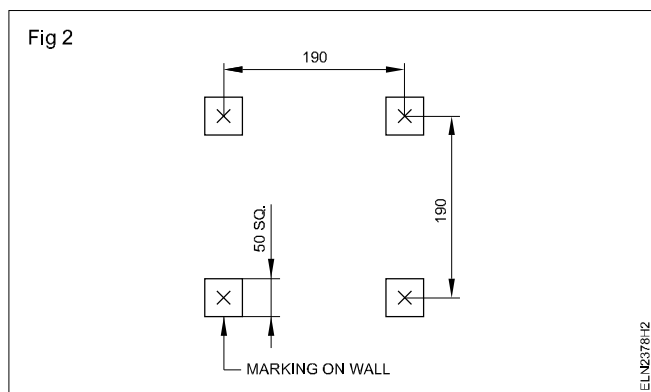

- Remove the plaster and the brick at the marked surfaces to a depth of 70 mm from the wall surface with the help of a cold chisel and hammer.
- Prepare cement and sand mortar in the ratio of 1:4.

Let the mortar be in a semi-solid condition.

- Sprinkle water in all the pits.
- Insert a small quantity of cement mortar inside the pit with the help of a mason's trowel.
- Insert the wooden gutties inside the hole pit such that the broad portion is inside and the narrow portion is outside and is just flush with the surface of the wall. (Fig3)

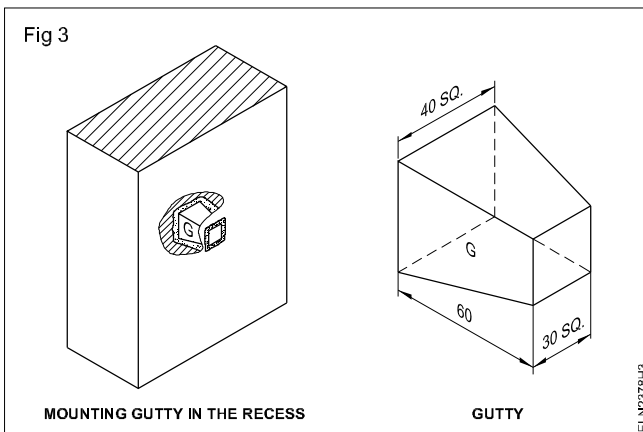

- Apply the cement on all sides of the gutty such that the gutty remains in the centre of the square hole.
- Smoothen the surface of the wall with a mason's trowel.

Allow the cement to dry for 4 hours and sprinkle water on the cement every one hour so that the cement settles. The gutties become rigid after approximately 24 hours. Then only the boards could be fixed on to the gutties.

Now the wall is ready for fixing the T.W. board.

- Fix the T.W. board with the help of 45mm long wood screws.

Trainees are required to identify the relationship between the stem thickness of 45mm long wood screws and the respective designation numbers.

TASK 2: Preparation of wall for drawing the service connection

Sometimes the service connection wires need to be taken through the wall using a G.I. pipe. There is then the necessity of making a hole through the wall with the help of a pipe jumper. The method to do it is as explained below. The diameter of the pipe jumper depends on the diameter of the service connection pipe and the length of the pipe jumper depends upon the wall thickness.

- Take a 20mm dia. G.I. pipe of 400mm length.
- Make serrations by cutting at one end of the pipe as shown in Fig 4 using a hacksaw.

This type of pipe jumper is also called crown jumper, due to its very look.

- Inspect the wall and mark a place on the wall considering the nearest point to the electric service pole.

Fig 4

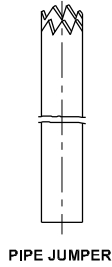

PIPE JUMPER

ELN237814

The marking should be close to the meter terminals. It should not be on the R.C. beam or granite stone embedded in the wall.

In the case of an old building check whether any concealed wiring is running through the wall at the place of marking. In such cases the marking should be done at a different place. However, in buildings, where wiring exists, switch 'off' the mains, remove the fuse-carrier and keep it under your custody.

- Keep the pipe jumper on the mark and hammer it lightly.
- Rotate the pipe jumper for every stroke of hammer.

This process removes the broken masonry and allows free movement of the pipe jumper. Take care to keep the pipe jumper perpendicular to the wall surface.

- Slow down the hammer strokes when the pipe jumper reaches near to the other end of the wall.

Hitting hard on the hammer at the end of a hole will make a larger sized plaster to fall out at the other end of wall.

- Clear the hole.
- Insert the G.I. pipe for the service cable in the hole and plaster around the pipe with cement.

Wiring up a meter board

- Confirm the capacity of the energy meter.
- Select and confirm the size of the cable as per the meter rating.

Follow the standard colour code for phase and neutral.

- Position the meter, I.C. cut-out and earth-plate as per layout (Fig 5) and mark their position as per layout on the T.W. board.
- Mark the cable entry positions and mounting screw positions.
- Select the drill bit according to the cable size.
- Drill through holes in the T.W. board for cable entry and pilot holes for fixing the meter, I.C. cut out and the earth plate.

Fig 5

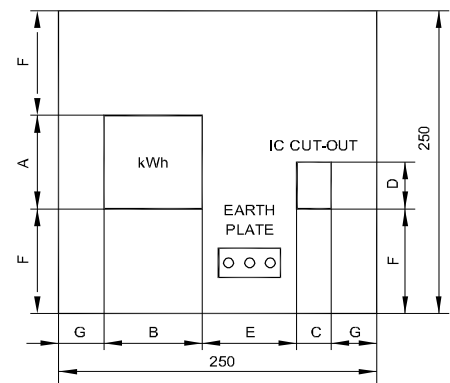

A-B OUTSIDE MEASUREMENTS OF ENERGY METER

$$F = \frac{250 - A}{2}$$

C-D OUTSIDE MEASUREMENTS OF METAL CLAD (IRON CLAD) CUT - OUT
E = 50mm

$$G = \frac{250 - B - C - E}{2}$$

INSTALLATION PLAN

ELN237815

- Fix the meter, I.C. cut out and the earth plate.
- Determine the length of the cables according to the layout and cut them with reference to Figs 5 and 6.

Fig 6

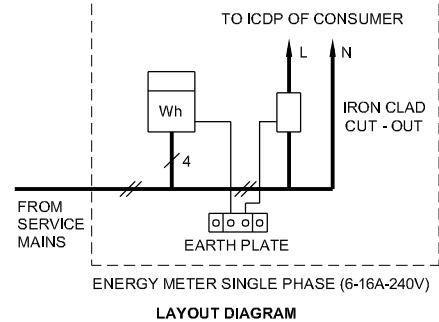

ENERGY METER SINGLE PHASE (6-16A-240V)

LAYOUT DIAGRAM

ELN237816

- Connect the supply leads and the outgoing phase wire to the I.C. cut-out. Pass the neutral directly as per the wiring diagram. (Figs 7 and 8)

Fig 7

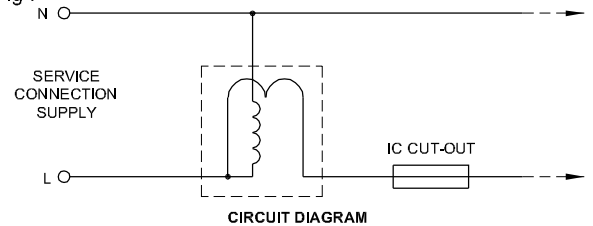

CIRCUIT DIAGRAM

ELN237817

Fig 8

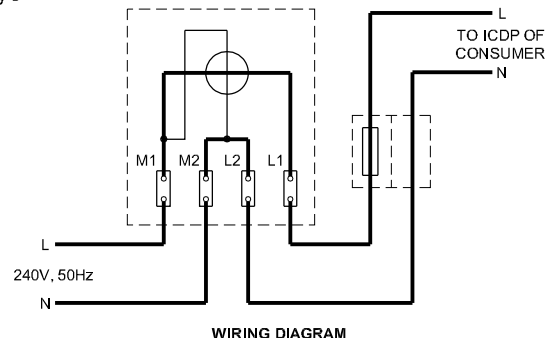

WIRING DIAGRAM

ELN237818

- 10 Earth the casing of the meter and the I.C. cut out body to the earth plate.
 - 11 Keeping the meter board in a vertical position, test the circuit after getting the approval of the instructor.
 - 12 Mount the meter board on the previously prepared wall with the help of 45mm wood screws.
- The completed work should look as shown in Fig 9.

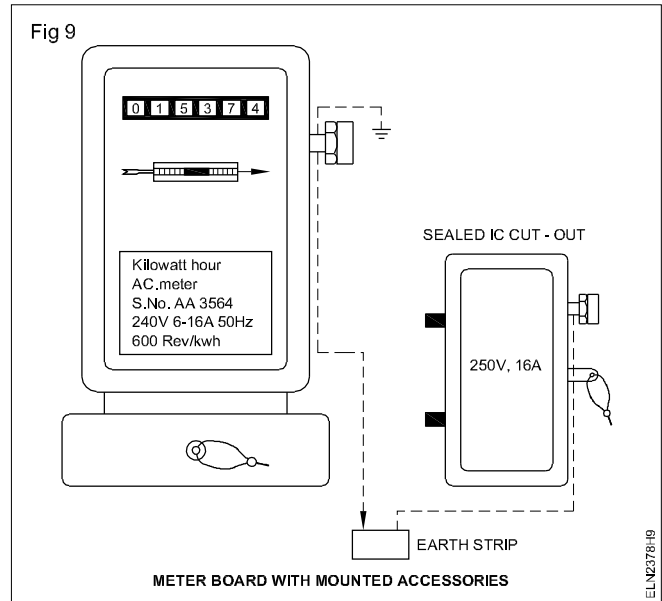

Estimate the cost/bill of material for wiring of hostel/residential building and workshop

Objectives: At the end of this exercise you shall be able to

- calculate the total load in sub-circuit
- select the size of cable in the sub circuits
- estimate the quantity of materials
- estimate the cost of wiring.

Requirements			
Tools/Instruments		Materials	
• Measuring tape 0-25 m	- 1 No.	• A-4 Paper	- as reqd.
• SWG	- 1 No.	• Pencil/HP	- 1 No.
• Steel rule 300 mm	- 1 No.	• Eraser	- 1 No.
• Micrometer 0-25 mm	- 1 No.		

PROCEDURE

TASK 1 : Estimate the cost/bill of material for wiring of hostel / residential building

1 Obtain the building plan as shown in Fig.1

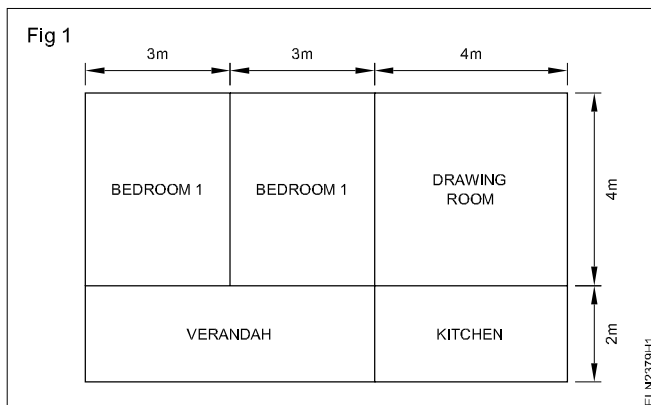

The type and quantity of loads depend upon the customer's requirement. Hence, complete data are to be collected before starting estimation. A sample requirements is given for the trainee's reference.

- The wall thickness - 40 cm
- The height of roof from ground - 3.5 m
- Height of conduit run - 3 m
- Height of main board - 2.5 m
- Height of switch - 1.5 m
- Height of light brackets - 3 m
- Height of main board - 3 m

- 2 Collect the requirements of lights, fans, lighting and power sockets etc.
- 3 Mark the location of switch board, Power loads and DB in the plan.

The details of standard requirement of Power loads are given in Table - 1

Table-1

Location	Light (60 W)	Fan (80 W)	6A Plug Point (80 W)	16A Power Plug (1000 W)
Verandah	1	1	1	1
Kitchen	1	1	Nil	1
Bedroom	2 + 2	1 + 1	1 + 1	Nil
Drawing Room	2	1	1	Nil

- 4 Calculate the number of sub circuits required for the above load as per IE rules.

Indian electricity rule states that there should be separate sub circuits for light/fan loads and power loads. Therefore 6A plug points (Sockets) are considered as light / fan load points as they are meant for connecting table fan /table lamp etc. 16A power plug are considered as power points as they are used for connecting heavy loads like heaters, kettles etc.

Total wattage of light points	= 8 x 60 = 480 W
Total wattage of fan points	= 5 x 80 = 400 W
Total wattage of (6A) sockets	= 4 x 80 = 320 W
Total 17 Nos	= 1200 W

As there are 17 points, we need two sub - circuits. The division of outlets on each sub circuit is made more or less uniform, ie., 8 & 9. Refer Fig 2

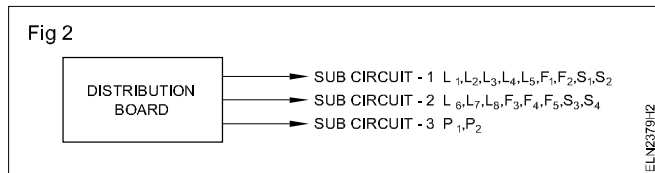

- 5 Draw the layout of conduit, switch board, loads and DB as shown in Fig 3.

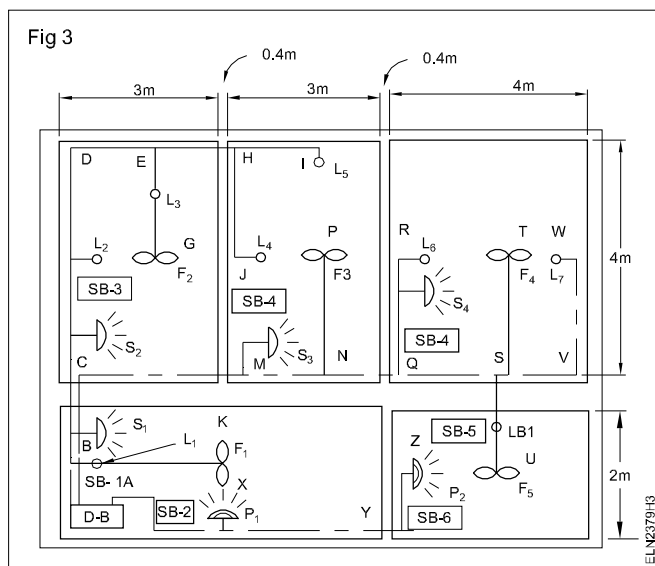

- 6 Calculate the size of each cable as shown below.

- i current through subcircuit-1

$$= \frac{(5 \times 60) + (2 \times 80) + (2 \times 80)}{230} = 2.696 \text{ A}$$

- ii Current through subcircuit -2

$$= \frac{(3 \times 60) + (3 \times 80) + (2 \times 80)}{230} = 2.522 \text{ A}$$

- iii Current through sub circuit 3 = $\frac{2000}{230} = 8.696 \text{ A}$

$$\text{Total current} = 2.696 + 2.522 + 8.696 = 13.9 \text{ A}$$

16A, 250V flush type DP main switch is sufficient

- 7 Calculate the length of PVC conduit and cable as shown below.

19mm conduit can be used up to ABC length and for remaining length, 12mm conduit is sufficient.

Horizontal runs

19mm conduit for length ABC = 2.4 m

19mm conduit for length at C (wall thickness) = 0.4 m

Total = 2.8 m

12 mm Conduit

Length CDEHI (4 + 3 + 1.5) = 8.5 m

Length EG = 2.0 m

Length HJ = 2.0 m

Length CMNQS VW (3+3+4+2) = 12.0 m

Length MS3 = 1.5 m

Length NP = 2.0 m

Length QR = 2.0 m

Length ST = 2.0 m

Length SV = 1.0m

Length BK = 3.0 m

Length XYZ (6+1) = 7.0 m

Length (wall thickness) at C, H, M, Q, S & Y (6x0.4) = 2.4 m

Total = 45.4 m

Vertical down drops (horizontal run to SB's) :

19 mm conduit

Length B to roof = 0.5 m

Length E to roof = 0.5 m

Length N to roof = 0.5 m

Length S to roof = 0.5 m

Total = 2.0 M

Total 19 mm conduit required = 2.8+1.5+0.5 = 4.8 m

Wastage 10% = 0.48 m

Total = 5.28 m

(Take 6m)

Total 12mm conduit required 45.4+10.50 = 55.9 M

Wastage 10% = 5.59 m

Total = 61.49 m

(Take 62m)

Cable for (power) sub circuit -3 (1/1.8m Al)

$$= 3 \times (6+1+1.5+1.5) = 30 \text{ m}$$

Cable for subcircuit 1 & 2 (1.0 mm² copper)

$$= 3 \times (6+62-10) = 174 \text{ m}$$

Trainee shall select the cable size by referring the table given in related theory

8 Calculate the labour cost.	
Meter board	= 2 Points
Distribution board	= 2 Points
Light / fan	= 17 Points
Power	= 2 Points
Total points	= 23 Points

Labour cost /point should be taken by referring the local rate list.

For example, take the labour cost is Rs.100/point

Then, total labour cost is 23 x 100 = Rs. 2300/-

9 Prepare a list of "material of schedule and cost" as shown in Table-2.

Table2

Material of schedule and cost

Sl.No.	Material Specification	Rate Cost				Remarks
		Qty.	Rs. Ps.	Per	Rs. Ps.	
1	D.P Main switch 10A, 240V flush type	1 No	each	For M.B For power load
2	I.C cut out 16A, 240V	1 No	each	
3	Flush type fuse unit 16A	1 No	each	
4	Flush type fuse unit 6A	2 Nos	each	1 length = 3 m
5	PVC conduit 19 mm (heavy guage)	6 m	length	
6	PVC conduit 12 mm (heavy guage)	62 m	length	1 length = 3 m
7	1.0mm ² multistrand copper, VIR cable	174 m	100m	From M.B to D.B
8	1/1.8 mm aluminium VIR cable	30 m	100m	
9	1/1.8m copper VIR cable	2 m	100 m	
10	Switches 6A, 240V one way flush type	17 Nos	each	For M.B & D.B For S.D's
11	2-pin sockets 6A, 240V	4 Nos	each	
12	3 -pin sockets 16A, 240V with switch and neon	2 Nos	each	
13	Ceiling rose 2 - plate 6A 240V	5 Nos	each	
14	Lamp holders brass batten type	8 Nos	each	
15	PVC junction boxes 25 mm 4 - way 12 mm 3-way 12 mm 2-way	1 No	each	
		7 Nos	each	
		5 Nos	each	
16	PVC bends 12 mm	4 Nos	each	
17	PVC reducers (25 mm to 12 mm)	1 No	each	
18	Saddles 25 mm 12 mm	24Nos	Doz	
		144No	144 Nos	
19	Wooden boards (a) 30 x 30 Cm (b) 18x10 Cm	2 Nos	each	
		7 Nos	each	
20	Round blocks	5 Nos	each	
21	Wooden gutties/plugs 9cm ² x 4 cm ² x50 mm	3 doz	doz	
22	Nails 25 mm	1 kg	kg	
23	Wooden screw 60 mm	25 Nos	100	
	Wooden screw 12 mm	25 Nos	100	
24	Copper wire (16SWG) for earth	1 Kg	kg	
	(GI WIRE 14 SWG)	1 Kg	kg	
25	Earth set (Pipe, salt, coal)	1 set	
26	Cement	2 kg	kg	
27	Labour cost	2 kg	
	Total				
	Contingency 10%				
	Grand Total				

The rate of each material shall be obtained from the price list of the branded items

TASK 2 : Estimate the cost / bill of materials for wiring of workshop.

- 1 Obtain the floor plan of the workshop.
- 2 Mark the positions of motors on the floor plan with the consultation of the customer.

A sample requirement is given below for trainee's reference

- 1 One 5HP, 415V 3 phase motor
- 2 One 3HP, 415V 3 phase motor
- 3 One ½ HP, 240V 1 phase motor
- 4 One 1HP, 415V 3 phase motor

The motors are to be arranged as shown in Fig.4

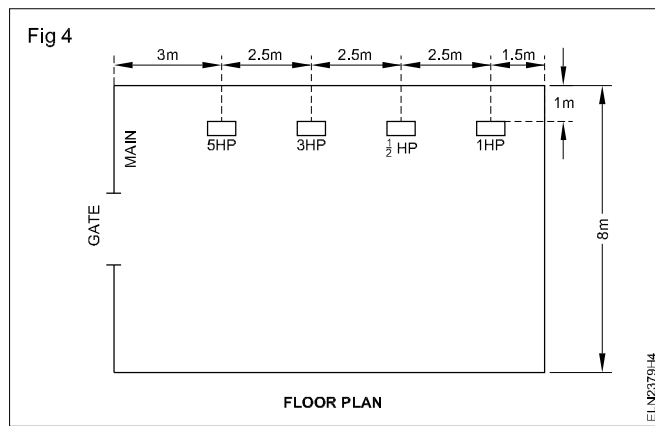

The main switch, motor switch and starters are assumed to be mounted at a height of 1.5m from the ground level.

Height of horizontal run from ground level will be 2.5 m

The cost of motors and starters are not to be included in the estimate.

- 3 Calculate the size of cable

Assuming the motor efficiency to be 85% power factor to be 0.8 and supply voltage is 400 V for all the motors.

$$\text{FL current of 5HP motor} = \frac{5 \times 735.5}{\sqrt{3} \times 400 \times 0.85 \times 0.8} = 7.806 \text{ A}$$

$$\text{FL current of 3HP motor} = \frac{3 \times 735.5}{\sqrt{3} \times 400 \times 0.85 \times 0.8} = 4.68 \text{ A}$$

$$\text{FL current of } \frac{1}{2} \text{ HP motor} = \frac{0.5 \times 735.5}{240 \times 0.85 \times 0.8} = 2.25 \text{ A}$$

$$\text{FL current of 1HP motor} = \frac{1 \times 735.5}{\sqrt{3} \times 400 \times 0.85 \times 0.8} = 1.56 \text{ A}$$

The main switch and the cable from meter to main switch should be capable of handling starting current of one motor of high rating plus full load current of the all other motors.

$$\text{i.e, } 15.6 + 4.68 + 2.25 + 1.56 = 24.9 \text{ A}$$

- 4 Prepare a table showing cable size of each motors to be installed as shown in Table 3.

Table 3

Sl. No.	Motor	FL current I_L (A)	Starting current $I_s = 2I_L$ (A)	Recommended cable size
1	5HP motor	7.5	15.0	2.0mm ² copper conductor cable (17A) or 2.5mm ² aluminium conductor cable (16A)
2	3HP motor	4.68	9.36	2.0mm ² copper conductor cable (17A)
3	1/2 HP motor	2.25	4.5	1.0mm ² copper conductor cable (11A) minimum recommended cable
4	1HP motor	1.56	3.12	1.0mm ² copper conductor cable (11A) minimum recommended cable

The type and gauge of cable shall be selected by referring the table given in related theory

5 Select the suitable switches and distribution board

- 32A, 415V ICTPN switch with fuses can be used as main switch.
- 16A, 415V, ICTPN switches with fuses can be used for 5HP, 3HP, & 1HP motors.

- 16A, 240V, ICDP switch with fuses can be used for ½ HP motor.
- 415V, 4 way, 16A per way IC distribution board with neutral link can be used for power distribution.

6 Draw the single line diagram of power wirings as shown in Fig 5.

7 Calculate the size and length of conduit.

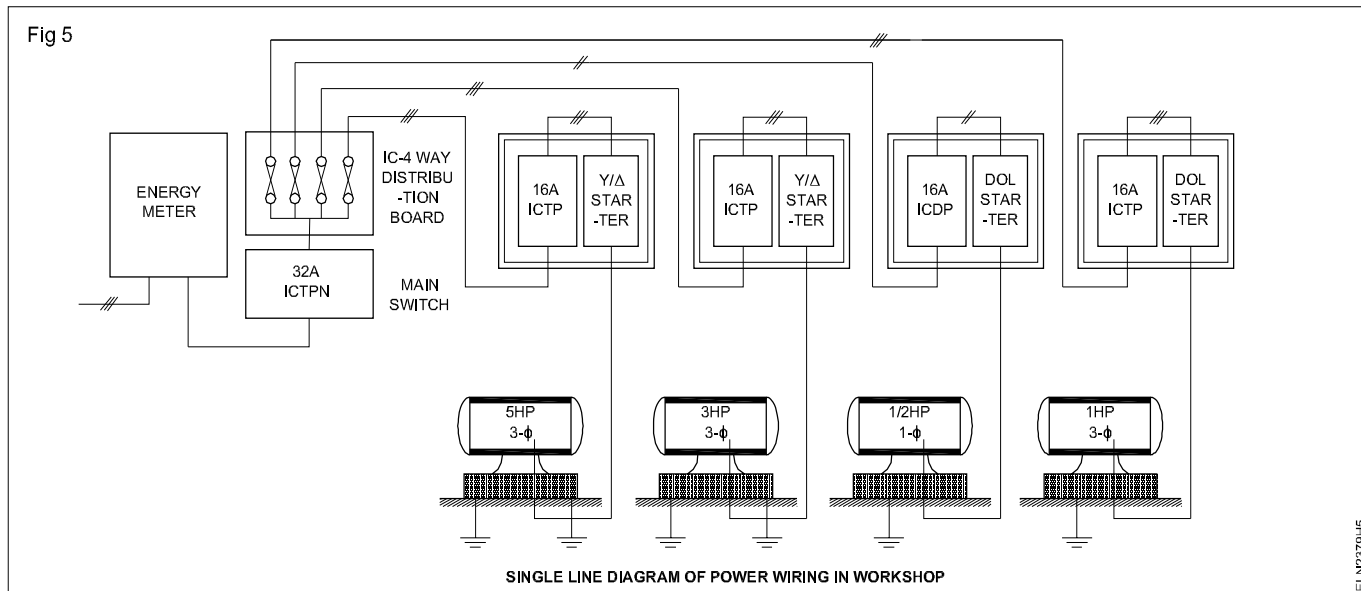

19mm heavy gauge conduit should be used for 3 cable runs and 25 mm heavy gauge conduits should be used for 6 cable runs.

- 19 mm heavy gauge conduit

Length from main board of 5HP motor starter

$$= 1+1+3+1 = 6.0\text{m}$$

Length from main board to 3HP motor starter

$$= 1+1+5.5+1 = 8.5\text{m}$$

Length from main board to ½ HP motor base

$$= 1+1+8+1+1.5+1.5 = 14.0\text{m}$$

Length from main board to 1HP motor base

$$= 1+1+10.5+1+1.5+1.5 = 16.5\text{m}$$

Total = 45.0 m

10% wastages = 4.5m

Total length = 49.5m, say 50.0m

- 25.4 mm heavy gauge conduit.

Length from meter to main switch = 0.75 m

Length from 5HP motor starter to 5HP motor base

$$(1.5 + 1.5) 3.0\text{m}$$

Length from 3HP motor starter to motor base = 3.0 m

Total = 6.75 m

10% wastage = 0.67 m

Total = 7.42m, Say 8.0m

- 25 mm flexible conduit for 5HP & 3HP motor (0.75+0.75) = 1.5, Say 2.0m

8 Calculate the length of cables.

2.0mm² copper conductor from main board to 5HP motor terminals = 3(1+1+3+1) + 6(1.5+1.5+0.75) = 40.5m

15% wastages & end connections = 7.2 m

Total = 55.2m, Say = 56.0m

1.0mm² copper conductor from main board to 1/2 HP motor terminals = 2(1+1+8+1+1.5+1.5+0.75) = 29.5 m

15% wastages & end connections = 7.76m

Total = 59.51m, Say 60.0m

9 Calculate the labour cost as per the local rate and rules for calculating number of points.

10 Prepare "Schedule of material and cost as shown in Table 4.

Table 4

Material of schedule and cost

Sl.No.	Specification of material	Qty.	Rate	Cost	Rs. Ps	Remarks	
			Rs. Ps.	Per			
1	32A, 415V- Iron -clad triple - pole (ICTPN) switch with fuses	1 No.	each		
2	16A, 415V, Iron- clad triple -pole switch with fuses	3 Nos.	each		
3	16A, 240V, Iron -clad double - pole switch with fuses	1 No.	each		
4	4-Way distribution box, 415V, 16A	1 No.	each		
5	Conduit heavy gauge	19 mm	50 m	m	
		25mm	8 m	m	
6	Flexible conduits	19 mm	2 m	m	
		25 m	2 m	m	
7	2.0 mm ² copper conductor single core (17A)	47 m	100 m		
8	1.0mm ² copper conductor single core (11A)	56 m	100 m		
9	1.0mm ² copper conductor single core (11A)	34 m	100 m		
10	1.0mm ² copper conductor single core (11A)	60 m	100 m		
11	Angle iron frame 50 x 30 m	5 Nos.	each	For M.B & D.B	
12	Conduit bends	19mm	10 Nos.	each	
		25 mm	2 No.	each	
13	Saddles	19 mm	150 Nos.	100	
		25 mm	25 No.	100	
14	Conduit couples	19mm	6 No.	each	
		25 mm	1 No.	each	
15	Wooden gutties	120 No.	doz		
16	Earth wire, GI, 8 SWG	40 m	kg.		1kg. \simeq 10 m
17	Lugs for connecting leads to motors	17 No.	each		(6+6+2+3)
18	Earthing pipe perforated 25.4mm dia	2.5 m	m		Two earths
19	Coal	40 kg.	kg.		
20	Salt	40 kg.	kg.		
21	Funnel with wire mesh	1 No.	each		
22	Labour charges for earthing (Civil work)	2 Nos.	pit		
23	Caution plate	1 No.	each		
24	Nails 25.4 mm	2	kg.		
25	Shock treatment chart	1	each		
26	Labour cost	-	point		
	Total		
	Contingency 10%		
	Grand total		
	Say		

Practice wiring of hostel and residential building as per IE rules

Objectives: At the end of this exercise you shall be able to

- read and interpret the circuit diagram of a bank/ hostel/ jail
- mark the layout of the wiring scheme
- prepare and install a conduit frame as per layout
- draw the cables through the conduit
- connect the accessories as per circuit
- test the circuits.

Requirements	
<p>Tools/Instruments</p> <ul style="list-style-type: none"> • Combination pliers 200 mm - 1 No. • Screw driver 200 mm with 4 mm blade - 1 No. • Side cutting pliers 150 mm - 1 No. • Electrician's knife 100 mm - 1 No. • Bradawl 150 mm - 1 No. • Ball peen hammer 250g - 1 No. • Hacksaw with 24 TPI blade - 1 No. • Firmer Chisel 6 mm - 1 No. • Flat rasp file 200 mm - 1 No. • Neon tester 500V - 1 No. • Electric drilling machine 6 mm capacity with 5mm drill bit. - 1 No. 	<p>Materials</p> <ul style="list-style-type: none"> • 2 way switch 6A 250V - 4 Nos. • Batten holder 6A 250V - 4 Nos. • PVC switch box 100 X 100 X 40 mm - 4 Nos. • PVC Cable 1.5 sq mm, 660 V - as reqd. • Saddle 19 mm - 20 Nos. • Wooden gutties - 20 Nos. • Conduit bend 19mm - 20 Nos. • Fish wire - as reqd. • PVC Conduit 19 mm - 50 m • Flexible conduit 19 mm - 2 m • Conduit coupler 19 mm - 6 Nos. • Earth wire G1, 8 SWG - 20 m • Wood Screw 25 x 6 mm - 1 box • Wood Screw 12 x 6 mm - 1 box

PROCEDURE

- 1 Read and interpret the schematic diagram (Fig 1) and the layout diagram (Fig 2).

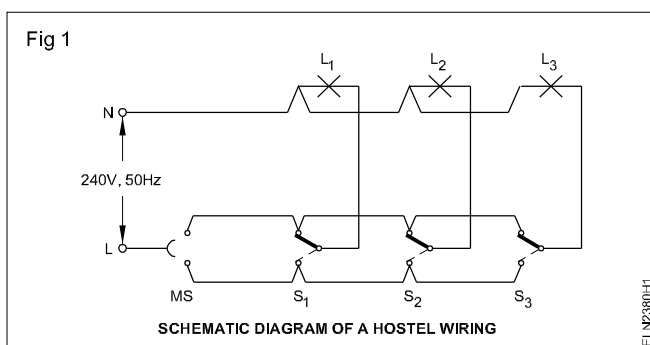

- 2 Draw the wiring diagram based on Figs 1 and 2 and compare with the given wiring diagram. (Fig 3).
- 3 Draw your own wiring diagram according to the layout.
- 4 Estimate the material required for wiring installation referring to the layout as well as the wiring diagrams.
- 5 Mark the layout on the Installation Practice Cubicle (IPC).
- 6 Prepare the PVC conduit frame as per the layout plan.
- 7 Mark the saddles position and fix them loosely as per the layout plan.

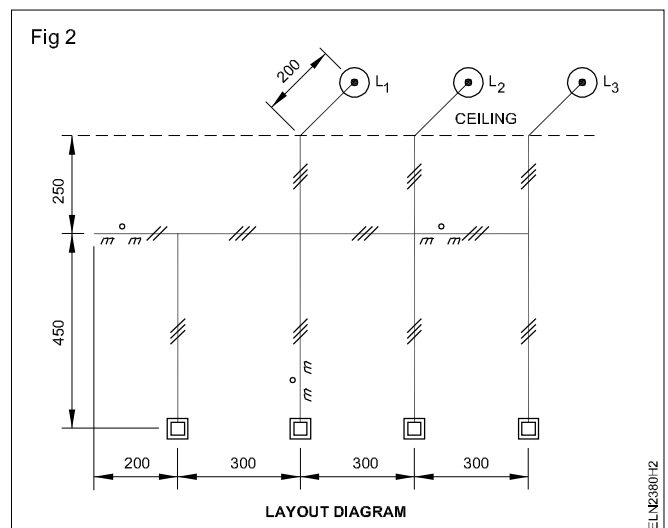

- 8 Fix the conduit pipe on the IPC with the help of saddles.
- 9 Insert the fish wire into the conduit pipe.
- 10 Draw the cable as per the wiring diagram. (Fig 3)

Leave an excess length of 200 to 300mm in each cable for termination

- 11 Fix the batten holders as per the Fig 2 and terminate the cable ends.

Fig 3

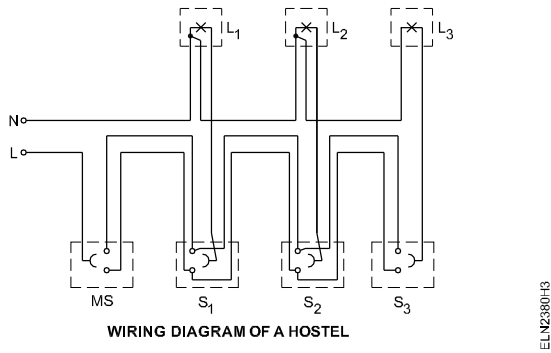

12 Fix the switches on the PVC switch boxes.

13 Prepare the end termination of cables and connect the accessories as per the circuit.

14 Test the circuit after getting the approval of the instructor.

Practice wiring of Institute and workshop as per IE rules

Objectives: At the end of this exercise you shall be able to

- read and interpret the floor plan of a workshop.
- mark the single line diagram of power wiring in workshop.
- prepare and install a conduit frame as per line diagram
- draw the cables through the conduit
- connect the accessories as per circuit
- test the circuits.

Requirements	
<p>Tools/Instruments</p> <ul style="list-style-type: none"> • Power drilling machine 6mm with 5 mm drill bit - 1 No. • Combination pliers 200 mm - 1 No. • Side cutting pliers 150 mm - 1 No. • Electrician's knife - 1 No. • Bradawl 150mm - 1 No. • Ball peen Hammer 250 gm - 1 No. • Hacksaw with 24 TPI blade - 1 No. • Firmer Chisel 6 mm - 1 No. • Neon Tester 500V - 1 No. • 3ϕ Energy meter 30A, 440V - 1 No. <p>Equipment / Machines</p> <ul style="list-style-type: none"> • 5 HP 3ϕ 440V AC motor - 1 No. • 3 HP 3ϕ 440V AC motor - 1 No. • 1/2 HP 1ϕ 240V AC motor - 1 No. • 1 HP 1ϕ 240V AC motor - 1 No. • Star Delta starter 4, 5V 50 Hz - 2 Nos • DOL starter 1ϕ, 10A, 250 V - 2 Nos. 	<p>Material</p> <ul style="list-style-type: none"> • PVC pipe 20 mm - 10 m • PVC ways junction box - 20 Nos. • TW box 200 X 150 X 40 mm - 3 Nos • TW box 300 x 200 x 40 mm - 4 Nos. • TPIC 16A - 415V - 2 Nos. • DPIC 16A, 250V - 2 Nos. • Saddles 19 mm - 50 Nos. • Wooden gutties - 50 Nos. • Conduit bend 19 mm - 10 Nos. • Angle Iron frame 50 x 30mm - 5 Nos. • Fish wire - as reqd. • PVC sheathed aluminium cable 4 Sq mm 250 V - 60 m • Copperwire 14 SWG - 15 meter • PVC Elbow 20 mm - 25 Nos. • Distribution box 4 ways 200x150x40mm - 1 No. • TW wooden spacer - 30 Nos. • Wood screws 25 x 6 mm - 1 Box • Wood screws 12 x 6 mm - 1 Box • Surface mounted kit kat fuse 16A 250V - 4 No.

PROCEDURE

1 Obtain the floor plan of the work shop (Fig 1).

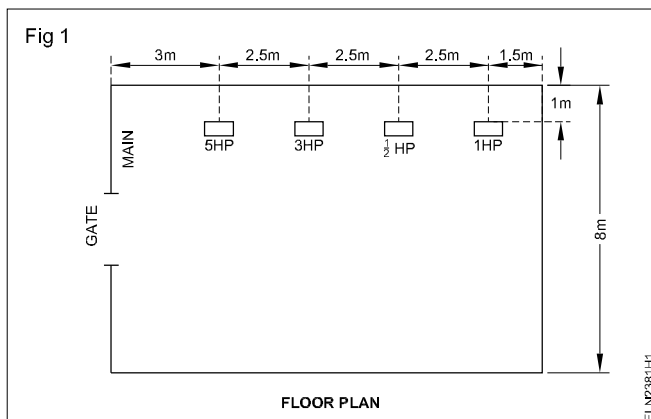

- 1 One 5 HP, 415V 3 phase motor.
- 2 One 3 HP, 415V 3 phase motor.
- 3 One 1/2 HP; 240V, 1 Phase moor
- 4 One 1 HP, 240V, 1 Phase motor

The motors are to be arranged as shown in Fig 1.

The mainswitch, motor switch and starter are assumed to be mounted at a height of 1.5 m from the ground level.

Height of horizotal run from ground level will be 2.5 m

2 Mark the position of motors on the floor plan with the consultation of the customer.

A Sample requirement is given below for trainees reference.

- 3 Draw the wiring diagram based on Fig 1.
- 4 Mark the layout based on Fig 2.
- 5 Prepare the PVC coduit frame as per layout.

Fig 2

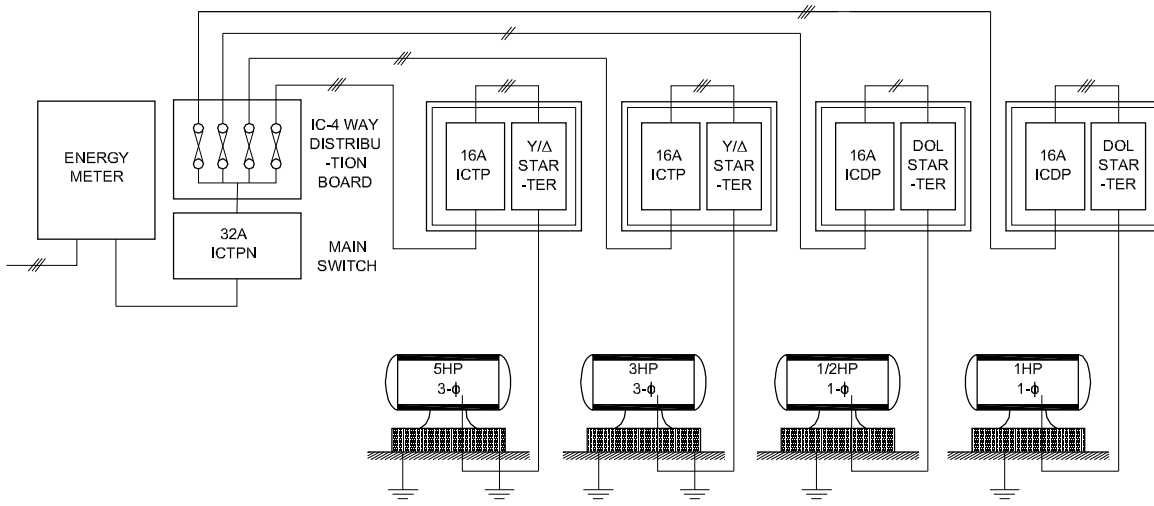

SINGLE LINE DIAGRAM OF POWER WIRING IN WORKSHOP

ELN238112

Practice testing /fault detection of domestic and industrial wiring installation and repair

Objectives: At the end of this exercise you shall be able to

- detect and repair open circuit fault in domestic and industrial wiring
- detect and repair shortcircuit fault in wiring
- detect and repair earth fault in wiring
- prepare the flow chart for location rectification of fault in domestic wiring installation.

Requirements	
Tools/Instruments	Materials
<ul style="list-style-type: none"> • Connecting screw driver 100 mm - 1 No. • Cutting plier 150 mm - 1 No. • Screw driver 200 mm - 1 No. • Neon tester 500 V - 1 No. • D.E. Electrician knife 100 mm - 1 No. • Multimeter - 1 No. • Megger 500V - 1 No. 	<ul style="list-style-type: none"> • Test lamp 100W, 240 V - 1 No. • Crocodile clip 15A - 2 sets • PVC flexible cable 1.5sq.mm, 660 V - 10m

PROCEDURE

Open Circuit Fault

- 1 Consider the circuit as shown in Fig 1 in a domestic installation.

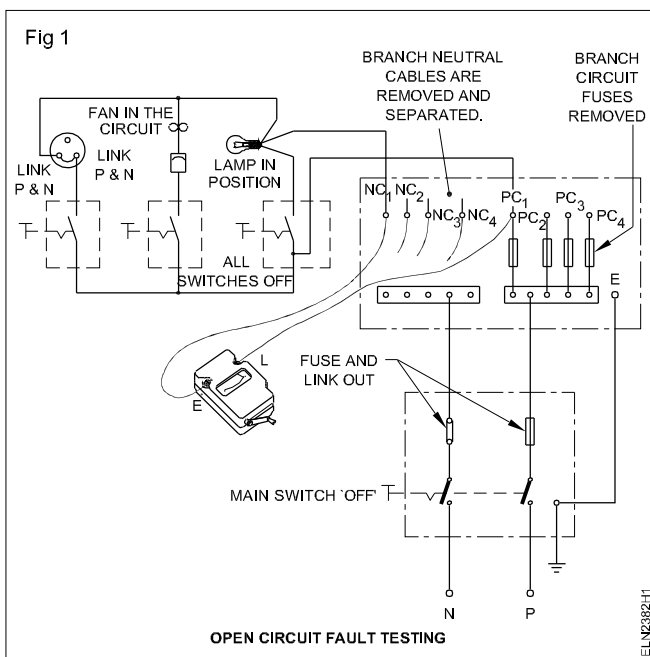

For open circuit fault removal of fuses, etc are to be done before doing the test by using megger.

- 2 Check whether the cables used in an installation have proper continuity or not using megger.
- 3 Check circuit fuses whether in order or not, if not, rewire the fuses.

- 4 Check one circuit at a time and then proceed step by step.
- 5 Check the circuits having 2 way switches, the concerned switches may be operated alternately to ensure the correct test result.
- 6 Check the defective fan, regulators or lamps by shorting the suspected appliance if necessary and then retest it.

Short circuit fault

- 1 Make the circuit as shown in Fig 2 and connect the megger, if it shows continuity in both ON and OFF positions of the switch, this indicates short in circuit.

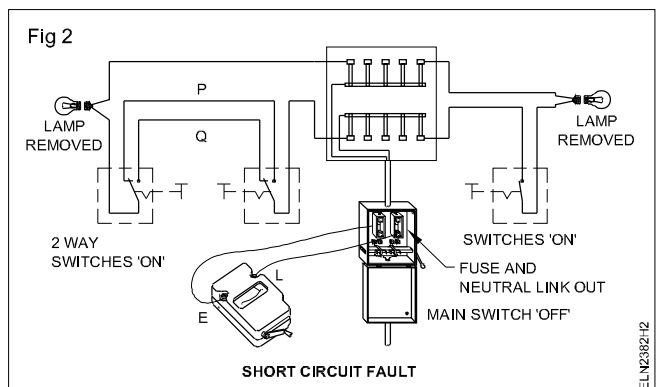

- 2 Check insulation resistance between the cables of the installation and earth.
- 3 Connect the megger terminal 'E' to the live wire and L to the corresponding neutral wire, the megger will read zero or very low value of insulation resistance and confirms the short circuit.

- Repeat the test procedures in each and every circuit and locate the shorting point of the live and neutral wire by inspection and remove it by insulating the bare conductors.

Isolate the live conductor from neutral, remove all other lamps and other equipments connected with wiring.

Earth fault

- As per the circuit as shown in Fig 3 keep all the fuses, switches bulbs etc in closed position as indicated in the figure.

- Switch 'ON' all the switches.
- Using Insulation resistance Tester, terminal 'E' of the megger connect to the earth point of the system provided at the Meter Board and Terminal 'L' of the megger with each conductor in turn at the main board cut-out terminal and rotate the handle of the megger to send current through closed circuit formed between conductor and earth.
- Note down the reading of the meter which gives directly the insulation resistance between the conductor and earth.
- Repeat the step 3 and 4 for other circuits, subcircuits, live conductors and main switch board etc.

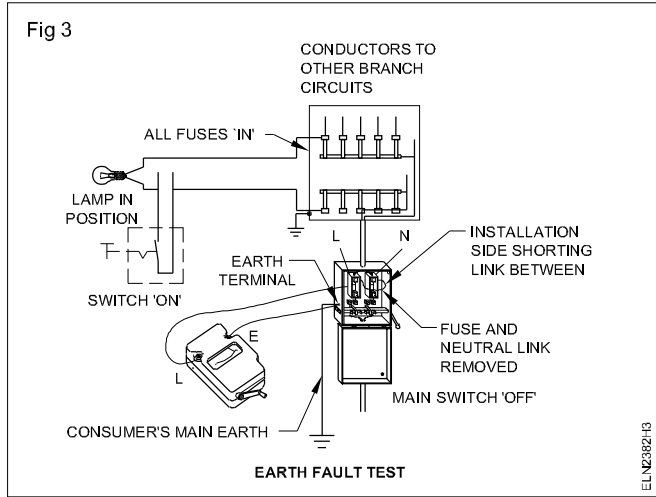

Flow chart for rectification of fault

Prepare the flowchart for finding fault and rectification

The Figure 4 shows the flow diagram for rectification of the fault in a domestic wiring installation.

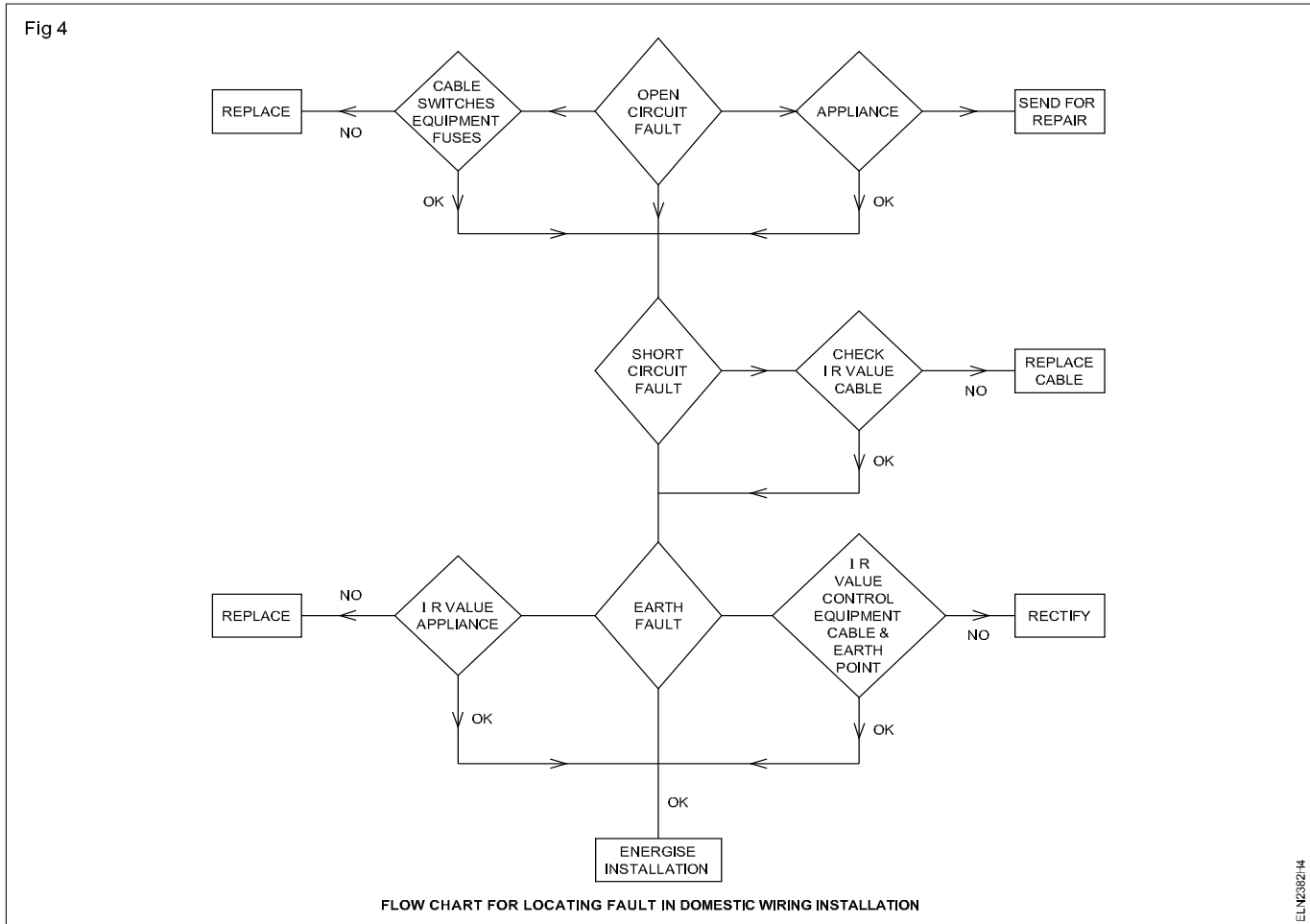

Prepare pipe earthing and measure earth resistance by earth tester/megger

Objectives: At the end of this exercise you shall be able to

- **prepare the pipe for earthing**
- **dig the pit in the ground**
- **install the earth pipe and test it.**

Requirements	
<p>Tools/Instruments</p> <ul style="list-style-type: none"> • G.I. die stock with 12.7 mm, 19mm and 38mm dies - 1 Set • D.E. spanners 5mm to 20mm of six. - 1 Set • Blowlamp, 1 litre with kerosene - 1 No. • Crowbar, hexagonal 1800mm long - 1 No. • Powrah (spade) - 1 No. • Pick axe - 1 No. • Cement mortar tray - 2 Nos. • Tongs 300mm - 1 No. • Measuring tape 5m - 1 No. • Ladle - 2 Nos. • Combination pliers 200mm - 1 No. • Pipe wrench 50mm - 1 No. • Hacksaw with 32 T.P.I. blade - 1 No. • Wooden box 150(l) x 150(b) x 300(h) mm - 1 No. • Soldering pot (melting) - 1 No. • Sledge Hammer 2 Kg. - 1 No. <p>Equipment/Machines</p> <ul style="list-style-type: none"> • Earth tester with connecting leads and spikes - 4 Nos. - 1 No. 	<p>Materials</p> <ul style="list-style-type: none"> • G.I. pipe 12.7mm dia. - 5 m • G.I. bend 12.7mm dia. - 2 Nos. • C.I. cover hinged to C.I. frame 300 mm square - 1 No. • G.I. pipe 19mm dia. - 1 m • G.I. pipe 38mm dia. having 12mm dia. holes - 2.5 m • Reducer 38 x 19 mm - 1 No. • Funnel with 19mm dia. sleeve & wire mesh - 1 No. • G.I. nut for 19mm dia. sleeve & wire mesh - 1 No. • G.I. check-nuts for 19mm dia. G.I. pipe - 4 Nos. • G.I. washer 40mm with 19mm hole - 1 No. • G.I. wire No.8 SWG - 10 m • Copper lug 200 amps with 19 mm dia. hole - 1 No. • Solder 60/40 - 100 gms. • Matchbox - 1 No. • Soldering paste - 10 gms. • Cement - 10 kgs. • Blue metal chips 6mm size - 40 kgs. • Riversand - 80 kgs • Salt (common) - 3 bags • Coke or charcoal - 3 bags

PROCEDURE

- 1 Collect G.I. pipes and the accessories.
- 2 Make a slant cut of 30° in the 38mm dia. G.I. pipe to have sharp edge as shown in Fig 1.
- 3 Make threads in the other end of 38mm dia. G.I. pipe to a length of 25mm.
- 4 Make threads in both ends of 19mm dia. G.I. pipe to a length of 25mm on one side and 75mm on the other side.
- 5 Fabricate the 38mm and 19mm dia. G.I. pipes as shown in Fig 1.
- 6 Select an earth pit site atleast 1.5 metres away from the building foundation.

An earth electrode should not be installed in proximity to a metal fence to avoid the possibility of the fence becoming live. If the metal fence is unavoidable, it should be earthed.

- 7 Dig an earth pit of dimensions 1 m width x 1 m breadth x 3.75 m depth.

The depth given here is the minimum recommended. However, the depth may be increased till moist soil is reached.

- 8 Place the fabricated pipe in an upright position as shown in Fig 1 and position the pipe with the help of bamboo sticks.

- 9 Place the wooden box around the pipe and fill it to a height of about 15cm with charcoal, and fill the surrounding outer space of the box with soil.

It is difficult to dig a pit 150mm square. A pit of dimension 1 metre square is therefore suggested to be dug. The area sufficient to be filled with salt and charcoal is about 150mm square. Hence fill the surrounding extra area with the soil which was taken out earlier.

- 10 Lift and place the wooden box above the coke layer. Fill up with salt to a height of about 15cm and to an area of 150 x 150mm area around the pipe.

Fill up the surrounding area with soil.

- 11 Repeat the above steps 10 and 11 up to 2.5 metres as shown in Fig 1.
12 Place the G.I. pipe 12.7 mm dia. meter with G.I. bends in proper position for E.C.C. connection.

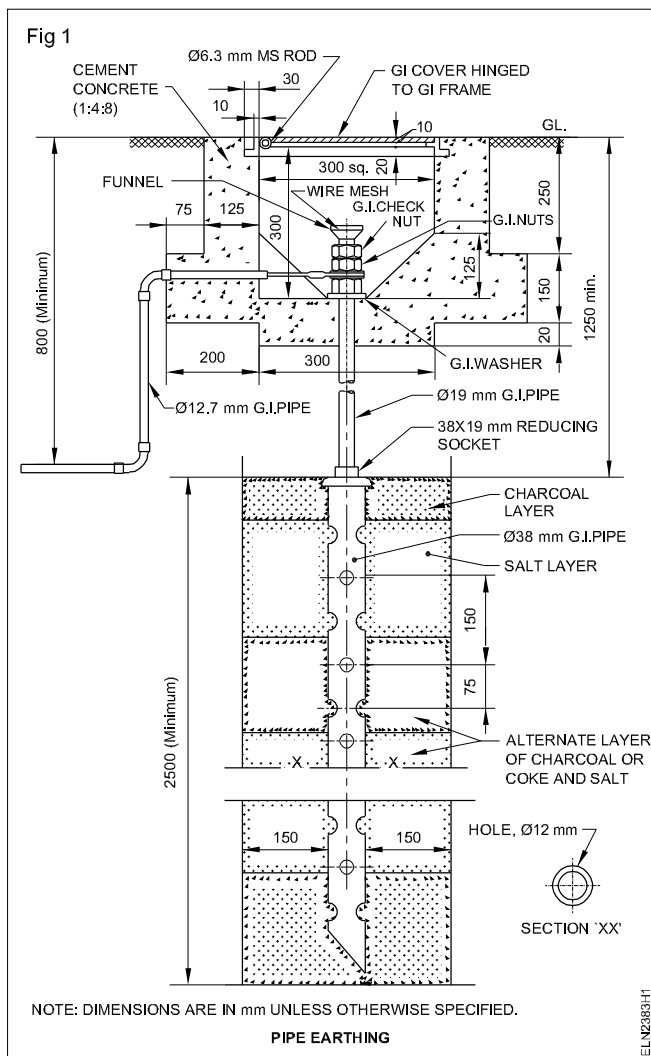

- 13 Prepare the concrete mixture and build the structure as shown in Fig 1.

- 14 Fix the G.I. cover also.

Atleast allow one day for curing the concrete structure. Pour water every 2 hours. (A wetted gunny sack will hold the moisture for several hours.)

- 15 Insert the G.I. wire No.8 SWG through the 12.7mm dia. G.I. pipe.

The size of the earth wire depends upon the incoming supply cable size.

- 16 Use the ladle and the blowlamp and melt the solder.

- 17 Solder the lug in the G.I. wire.

- 18 Insert the lug in the 19mm dia. G.I. pipe and tighten it with the G.I. nut and check-nut.

- 19 Pour three or four buckets of water through the funnel.

Allow an hour for the water to be absorbed in the earth.

- 20 Test the earth electrode resistance with an earth Megger.

The earth continuity conductor (E.C.C.) should not be connected to the earth electrode while measuring the earth electrode resistance.)

- 21 Enter the value of the earth electrode resistance in Column 5 of Table 1. Fill up the other particulars also. The acceptable value of the earth electrode resistance has been given earlier. Check the value if it.

- 22 Check the value of the earth resistance is found higher than the acceptable value, make one more pipe earth electrode at a distance of 8 metres from the earlier one and connect both of them in parallel.

- 23 Measure the earth electrode value and enter it in Column 6 of Table 1.

The second reading with two electrodes will be approximately half the first reading which was taken with one electrode. The measured value should be within the recommended value.

- 24 Get it checked with your instructor.

Table 1

Sl.No.	Date	Climate	Earth electrode Location	Earth resistance in ohms		Remarks
				Single	Double	
1	2	3	4	5	6	7

Prepare plate earthing and measure earth resistance by earth tester / megger

Objectives: At the end of this exercise you shall be able to

- prepare the plate for earthing according to ISI standard
- prepare the earthing pit in ground according to required standard
- install the plate in earthing pit
- test the earthing and measure the earth resistance using earth tester / Megger.

Requirements	
<p>Tools/Instruments</p> <ul style="list-style-type: none"> • G.I. die stock with 12.7 mm, 19mm and 38mm die - 1 Set • D.E. spanner set 6mm to 25mm - 1 Set • Blowlamp, 1 Pint - 1 No. • Crowbar 38mm x 1800mm long - 1 No. • Spade 300mm x 150mm - 1 No. • Cement mortar tray - 1 No. • Tongs 300mm - 1 No. • Hacksaw frame with 24 TPI blade - 1 No. • Pipe wrench 50mm - 1 No. • Soldering pot with ladle - 1 No. • Combination pliers 200mm - 1 No. • Measuring tape 5m - 1 No. • Sledge Hammer 2 Kg. - 1 No. <p>Equipment/Machines</p> <ul style="list-style-type: none"> • Earth tester with spikes and connecting lead - 1 Set 	<p>Materials</p> <ul style="list-style-type: none"> • G.I. plate 600mm x 600mm x 6.3mm - 1 No. • G.I. pipe 12.7mm dia. - 5 m. • G.I. pipe 19mm dia. - 1 m. • C.I. cover hinged to C.I. frame 300mm square - 1 No. • Funnel with 19mm dia. sleeve & wire mesh - 1 No. • G.I. nut for 19mm dia. sleeve & wire mesh - 2 Nos. • G.I. check-nuts for 19mm dia. G.I. pipe - 2 Nos. • G.I. washer 40mm with 19mm hole - 2 No. • G.I. wire No.8 SWG - 10 m • Copper lug 200 amps with 19mm dia. hole - 1 m • Solder 60x40 - 100gms. • Soldering paste - 10 gms. • Matchbox - 1 No. • Cement - 10 kgs. • Blue metal chips 6mm size - 40 kgs. • River sand - 80 kgs. • Charcoal or coke - 5 kgs. • Common Salt - 5 Kgs.

PROCEDURE

TASK 1: Prepare the plate for earthing according to ISI standard

- 1 Collect G.I plate and accessories for earthing
- 2 Mark thread on one side of 19mm dia GI pipes to a length of 25mm
- 3 Fabricate GI plate as shown in Fig 1 600mm x 600mm square plate with a thickness of 6.3mm
- 4 Fabricate 19mm dia G.I pipe as shown in Fig 2

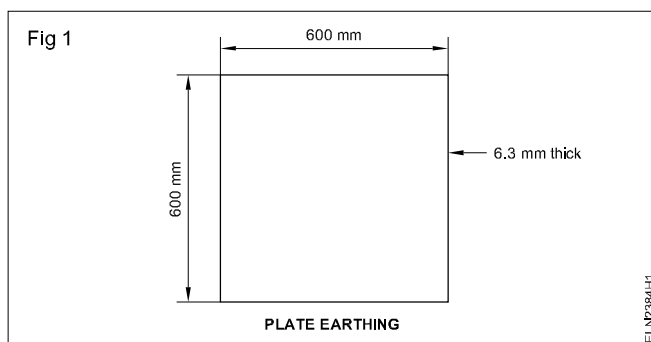

TASK 2 : Prepare the earthing pit in ground as per standard

- 1 Select an earth pit site atleast 1.5meters away from the building foundation

An earth electrode should not be installed is proximity to a metal fence to avoid the possibility of the fence becoming live. If the metal fence is un avoidable it should be earthed

- 2 Dig an earth pit of dimensions 1m width x 1m breadth x 2.5m depth

The depth given here is the minimum recommended. However the depth may be increased till moist soil is reached

- 3 Fabricate G.I pipe 12.7mm diameter with GI bonds in proper position and insert the G.I wire missing through GI pipe by soldering lug at external and fix GI plate with bolt and nut as shown in (Fig 2)

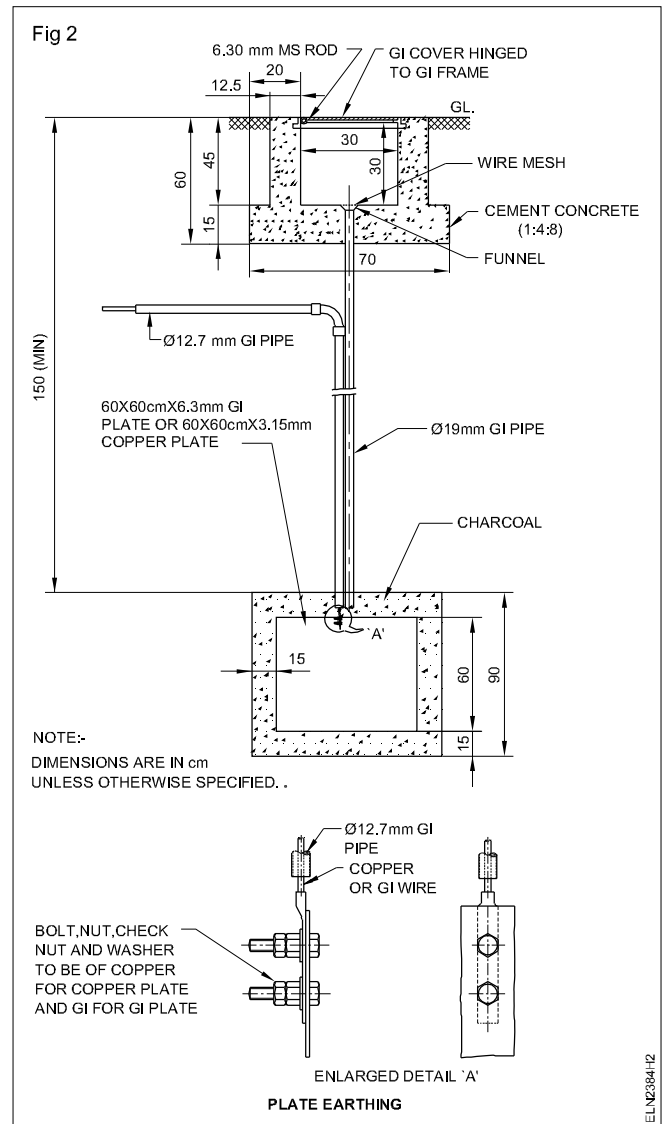

TASK 3 : Install the plate in earthing pit already prepared

- 1 Place the fabricated 19mm GI plate in an upright position as shown in fig 2 and position the pipe with the helps bamboo sticks
- 2 Place the wooden box around the plate and fill it to a height of about 15cm with charcoal and fill the surrounding outer space of the box with soil.

It is difficult to dig a pit 150mm square .A pit of dimension 1 meter square is therefore suggested to be dig. The area sufficient to be filled with salt and charcoal is about 150mm square. Hence fill the surrounding area with the soil which was taken out earlier

- 3 Lift and place the wooden box above the coke layer and fill up with salt to a height of about 15cm and to an area of 150x 150mm area around the pipe.

Fill up the surrounding area with soil.

- 4 Prepare the concrete mixture and build the structure as shown in figure 2.
- 5 Fix the GI core with the plates

At least allow one day for curing the concrete structure. Pour water every 2 hours (A wetted gunny is a act will hold the moisture for several times.

- 6 Pour three or four buckets of water through the funnel to the earth pit

Allow an hour for the water to be absorbed in the earth.

TASK 4 : Test the earthing and measure the earth resistance using earth tester

- 1 Test the earth electrode resistance with an earth tester.
- 2 Record the earth electrode resistance.

If the earth resistance is found higher than the acceptable value, make one more plate earth electrode at a distance of 8 meters from the earth in one and connect both of them in parallel

The second reading with two electrodes will be approximately half the first reading which was taken with one electrode. The measured value should be within the recommended value. If not have another earth electrode may be distance of 8 meters from the other electrodes.

- 3 Measure the resistance of earth electrode value and record

Test earth leakage by ELCB and relay

Objectives: At the end of this exercise you shall be able to

- identify the terminals of ELCB
- connect the ELCB in an Power circuit and test its functioning
- measure the leakage current at which ELCB trips off.

Requirements	
<p>Tools/Instruments</p> <ul style="list-style-type: none"> • Cutting plier 150mm - 1 No. • Screw driver 150mm - 1 No. • Electrician's knife 100 mm - 1 No. • Wire stripper 150 mm - 1 No. • Ammeter MI (0 - 10A) - 1 No. • Ammeter MI (0 - 100mA) - 1 No. • Philips star screw driver 100 mm - 1 No. <p>Equipments</p> <ul style="list-style-type: none"> • ELCB 240V, 25A, 2 pole with Tripping leakage current 30mA - 1 No. • MCB 240V, 10A, 2 pole - 1 No. 	<p>Materials</p> <ul style="list-style-type: none"> • 10KW 1W wire wound variable resistor - 1 No. • 5KW 1W fixed resistor - 1 No. • Pushbutton switch 250V, 6A - 1 No. • Water rheostat - 1 No.

PROCEDURE

TASK 1 : Identify the terminals of ELCB

- 1 Collect the ELCB from your instructor and read the specification given on it.

Identify the supply terminals and load terminals referring the marking on the unit as given in Figure 1.

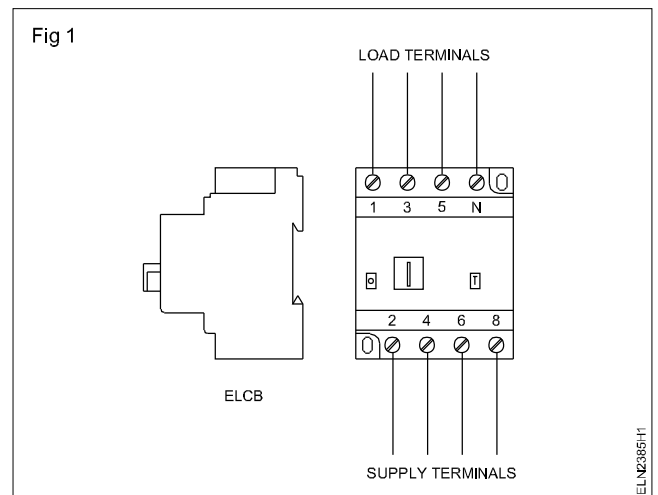

TASK 2 : Connect and test the operation of ELCB

- 1 Wire up the circuit as shown in the circuit diagram. (Fig2)
- 2 Switch on the main supply keeping the MCB and ELCB in ON position.
- 3 Close switch S₁ and operate the water rheostat till the ammeter 'A' reads about 5 A current.

Keep variable resistance in full cut in position.

- 4 Press the test switch and vary the variable resistance and note the leakage current and record

- 5 Record the leakage current at which the ELCB trips off

- 6 Open the external test switch and reset the ELCB.

- 7 Test ELCB for 'Trip function' by operating the 'Test button'. In this case the ELCB must trip off when the button is pressed.

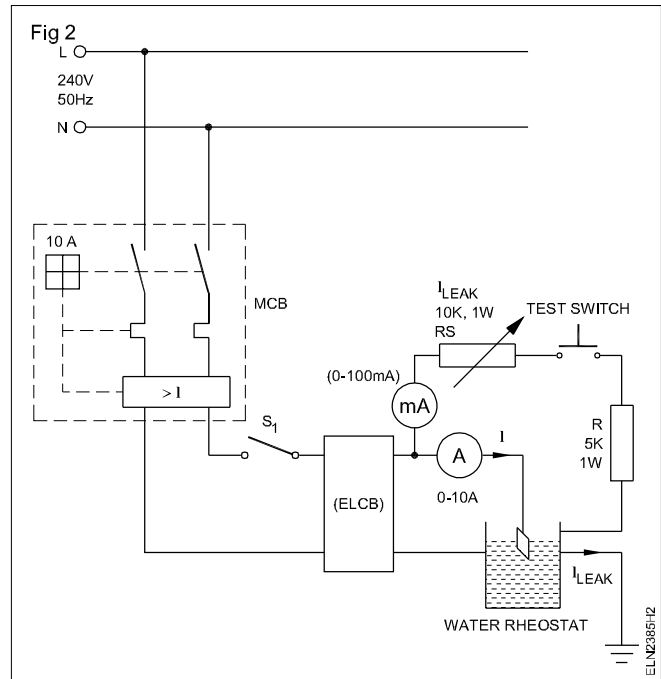

Install light fitting with reflectors for direct and indirect lightings

Objectives: At the end of this exercise you shall be able to

- design the light reflectors to a given room according to working situation
- install and check the effect of light reflection.

Requirements		
Tools/Instruments		Materials
<ul style="list-style-type: none"> • Cutting plier 200mm • Screw driver 150mm • Drilling machine electric 6 mm capacity with drill bit - 5 mm 	<ul style="list-style-type: none"> - 1 No. - 1 No. - 1 No. 	<ul style="list-style-type: none"> • Incandescent lamp 100W 240V with lamp shades of similar design • Reflector lamp 100W 240V • Silvered bowl lamp 100W 240 • Wiring materials
		<ul style="list-style-type: none"> - 2 No. - 2 No. - 2 No. - as reqd.

PROCEDURE

- 1 Identify the location and working situation, for light reflectors.
- 2 Carry out the marking for fixing the two ceiling roses at close proximity.
- 3 Carry out the wiring as per the circuit.
- 4 Check the wiring with a series test board.
- 5 Hang one lamp shade to face down, and one lamp shade up side down as shown in Fig 1 with suitable strings.
- 6 Fix similar type (incandescent) bulbs in both the shades.
- 7 Keep some display articles just beneath the lamp shades on a table.
- 8 Give the supply and check the lighting emitted by direct and indirect lights one by one.
- 9 Check the illumination of the lighting emitted by direct and indirect lights one by one.
- 10 Change the bulbs of similar variety (say reflector type) of same wattage in the shades and repeat the steps 8 and 9.
- 11 Write the conclusion based on the illumination level and suitability of direct and indirect lighting of displaying mercantize.

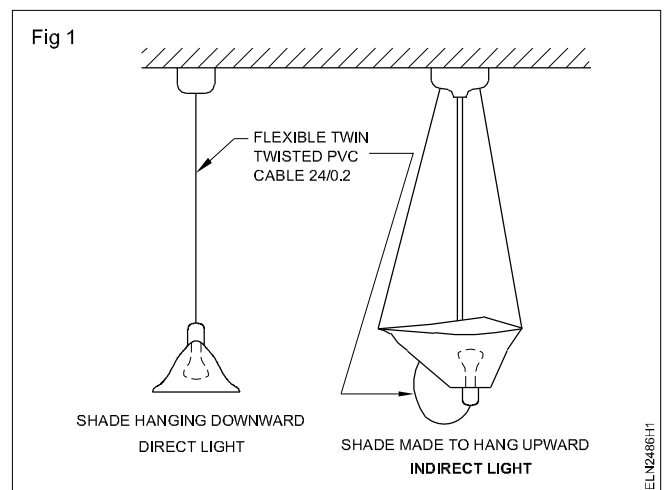

Conclusion :

Group different wattage lamps in series for specified voltage

Objectives: At the end of this exercise you shall be able to

- read and interpret the data stamped on a given lamp
- measure the voltage drop across the lamp when unequal wattage lamps are connected in series to the supply
- state the reasons for the behaviour/condition of glow of unequal wattage lamps in series.

Requirements	
Tools/Instruments	Materials
<ul style="list-style-type: none"> • Multimeter - 1 No. • Voltmeter MC 0-15V - 3 Nos. • Ammeter MC 0-500 mA - 1 No. 	<ul style="list-style-type: none"> • Bulbs screw cap - 6V 100 mA - 10 Nos. • Bulbs screw cap - 6V 150 mA - 6 Nos. • Bulbs screw cap - 6V 300 mA - 4 Nos. • Bulb-holders - 20 Nos. • Connecting leads - as reqd. • Knife switch DPST 16A - 1 No.
Equipment/Machines	
<ul style="list-style-type: none"> • DC variable source 0-24 volts, 5 amps with output current & voltage indicator - 1 No. 	

PROCEDURE

TASK 1 : Connect 3 lamps of 6 volts in series across 18 volts supply (unequal wattage) and test it

1 Connect the three lamps with ammeter A in series to the variable voltage DC supply source Fig 1a.

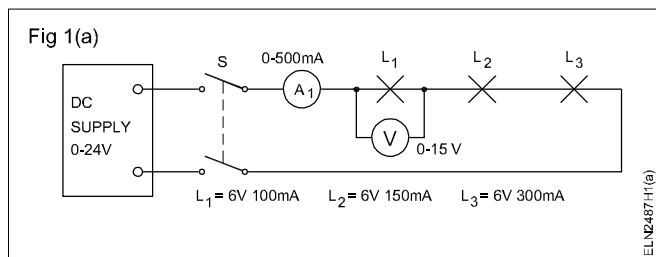

Keep the output of DC source at minimum, say 0 volts.

2 Connect a MC voltmeter (0-15 V) across L_1 (i.e low current rating/low wattage bulb). Close the switch S.

3 Gradually increase the supply voltage from 0 volts, observing ammeter, voltmeter and lamp L_1 .

4 Increase the voltage upto 18 volts. Record your observations.

5 Does the lamp L_1 fuse? If yes, give your reasons, stating the observation made just before fusing.

6 Open the switch S and reset the supply voltage to 0V. Replace the bulb L_1 .

7 Form the circuit Fig 1(b) with 3 voltmeters 0-15 volts connected across each lamp.

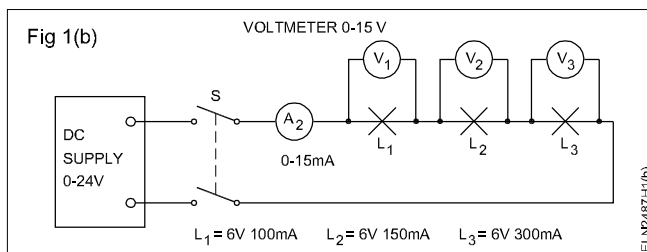

8 Close the switch S and increase the supply voltage until the current reaches 100 mA., (i.e. rated current of low wattage bulb in the series circuit).

9 Read the voltages V_1 , V_2 & V_3 and record in Table 1.

Table 1

Supply Voltage	V_1	V_2	V_3

10 Give your reasons for the unequal distribution of supply voltage.

11 Connect each lamp L_1 , L_2 & L_3 independently in the circuit Fig 2 and record the value of current and voltage when the supply voltage is 6 V in Table 2.

Table 2

Lamp in circuit	Supply voltage	V	I	V/I
L ₁ 6 V 100 mA	6 V			
L ₂ 6 V 150 mA	6 V			
L ₃ 6 V 300 mA	6 V			

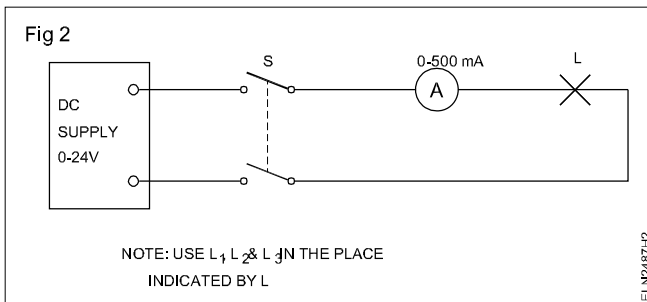

Conclusion

The voltage across each of the lamps connected in series varied because of

The stamped value of voltage and current on the lamp means that the specified _____ when applied will cause a _____ to flow.

Resistance of lamp varies because of different _____ of lamp.

TASK 2 : Connect two low wattage L₁ lamps in parallel as in Task 1 and test it

1 Form the circuit as per the diagram, Fig 3.

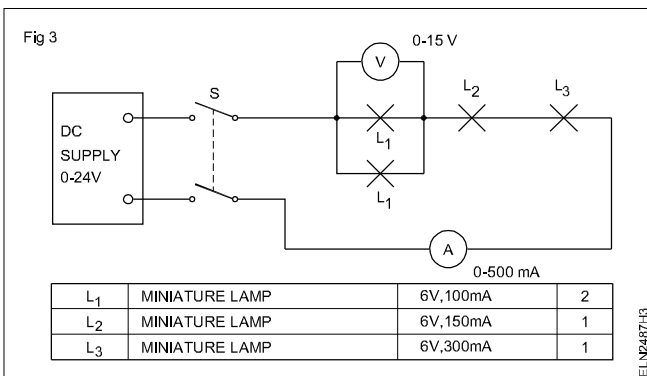

2 Observe the effect of increasing the supply voltage from 0 to a value that causes 6 volts across low wattage lamps L₁.

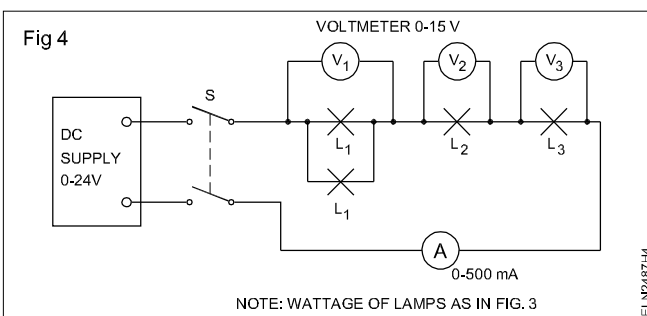

3 Does the lamp L₂ fuse? If yes, give your reasons stating observations made just at the time of L₂ fusing.

4 Open the switch S, connect the 3 voltmeters as shown in Fig 4.

5 Replace the lamp L₂ and reset the DC source at 0V. Close the switch S. Increase the supply voltage until a current of 150 mA flows in the circuit.

6 Read and record the voltages V₁, V₂ & V₃ in Table 3.

Table 3

Supply Voltage	V ₁	V ₂	V ₃

Conclusion

The voltage is V₂ is greater than V₁. Also V₂ > V₃, because

TASK 3 : Connect two (L₂ lamps) in parallel as in task 1 and test it

1 Form the circuit as shown in Fig 5.

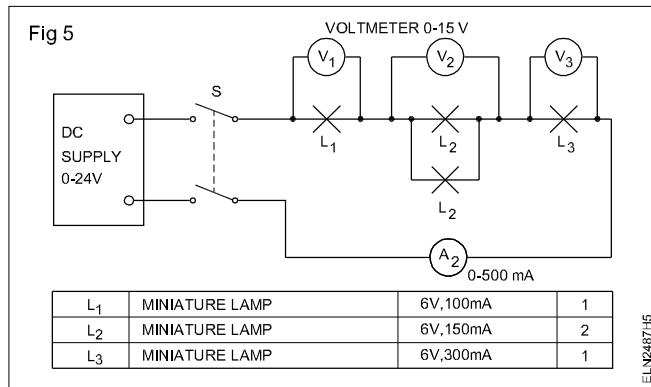

2 Gradually increase the supply voltage up to 18V after closing the switch S. Observe the voltage V₁, current and glow of lamp L₁.

3 Does the lamp L₁ fuse again? What are the conditions at the time of fusing?

_____ V₁
 _____ DC supply voltage
 _____ current

4 Is there any difference in the values as compared with the one in Task 1? Give your response.

5 Open the switch S. Replace the fused lamp L₁. Reset the supply voltage to 0V. Close the switch S and increase the current through the circuit to 100 mA. Record the voltages V₁, V₂ & V₃ in Table 4.

Table 4

Supply Voltage	V ₁	V ₂	V ₃

Conclusion

TASK 4 : Connect three L₁ lamps connected in parallel and the whole in series with one lamp L₃ two L₂ lamps in parallel as in task 1

1 Form the circuit as shown in Fig 6.

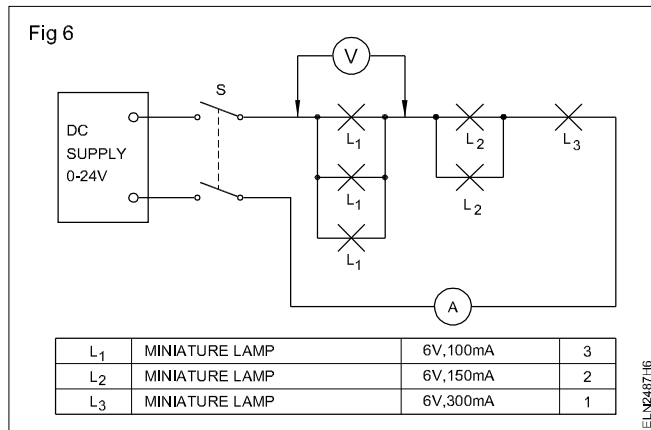

2 Close the switch S. Increase the supply voltage gradually to 18 V. Observe the lamps, ammeter and

measure the voltage across the lamp group L₁, lamp group L₂ and L₃.

3 Now all the lamps glow with their normal brightness. No lamp fused. Why?

Conclusion

In a serial set of lamps, while replacing a fused lamp the lamps voltage and also _____ or _____ should also _____ wattage lamp, replacement should be

Practice installation of various lamps eg. fluorescent tube, HP mercury vapour, LP mercury vapour, HP Sodium vapour, LP Sodium vapour, Metal halide etc.

Objectives: At the end of this exercise you shall be able to

- Connect a fluorescent tube with accessories, install and test it
- Assemble the instant start fluorescent lamp with an instant start ballast
- Assemble the rapid start fluorescent lamp fitting with accessories
- Connect a H.P. M.V lamp with accessories, install and test it
- Connect a H.P.S.V lamp with accessories install and test it
- Connect a L.P.S.V lamp with accessories install and test it
- Connect a metal halide lamp with accessories install and test it.

Requirements	
Tools/Instruments	
<ul style="list-style-type: none"> • Insulated combination plier - 150 mm - 1 No. • Insulated screwdriver - 200 mm x 4mm - 1 No. • Insulated connector screw driver - 100 mm - 1 No. • Long round nose plier - 150 mm - 1 No. • D.B. Electrician's knife 100 mm - 1 No. • Test lamp 100 W, 250 V - 1 No. 	<ul style="list-style-type: none"> • Choke 40w, 250V - 1 No. • Tube light starter - 40W,250V - 1 No. • Tube light holder plain - 2 Nos. • Starter holder - 2 Nos. • MV lamp holder suitable for 240W, 250 V lamp (Goliath screw type) - 2 Nos. • single patti - 1 No. • MV lamp choke - 240 Watts, 250 V - 1 No. • Capacitor 4 MFD / 380 U - 1 No. • L.P.M.V lamp 40 W, 250 V - 1 No. • MV lamp 240W, 250V - 1 No.
Materials	
<ul style="list-style-type: none"> • Tube light fitting 1200 mm - single patti - 1 No. 	

PROCEDURE

TASK 1: Assembling of a fluorescent lamp (LPMV lamp) with its accessories

- 1 Check the choke for its short and open with a test lamp as shown in Fig 1, and record the results.

Indicate the result by marking a tick (✓) here.

State of lamp glow	Condition of choke
a Normal glow	Internal short circuit
b Dim	Good working condition
c No glow even after checking the leads and connection	Open circuit in the choke

POSSIBLE RESULT
TESTING OF CHOKE

- 2 Check the starter with a series test lamp as shown in Fig2. Observe the flickering of the lamp which indicates good condition of the starter.
- 3 Assemble the following fluorescent tube accessories in the fitting base. Refer to the sketch. (Fig 3)

- 1) Holders for tube
- 2) Starter-holder
- 3) Choke.

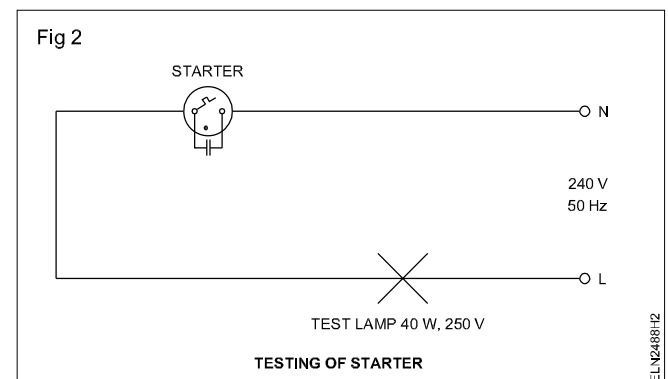
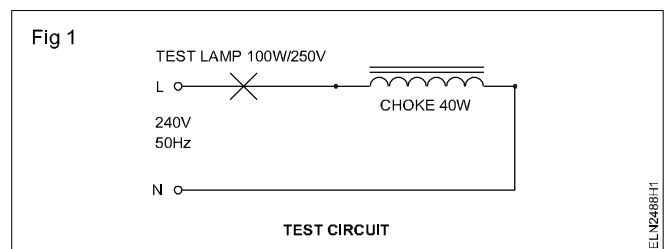

ELN2488H1

ELN2488H2

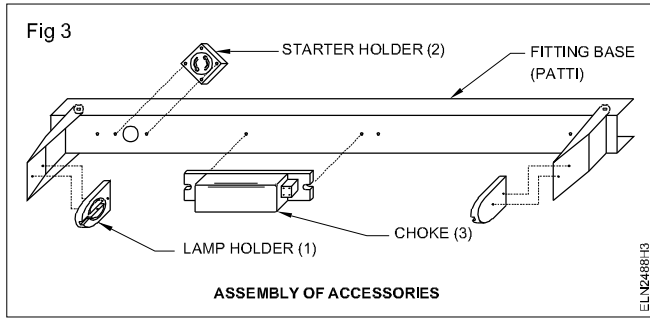

4 Connect the accessories as shown in Fig 4 (for a single tube light). Also install the tested starter.

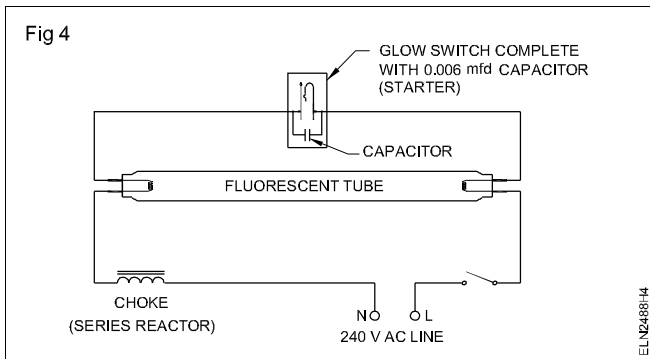

5 Test the filament on both sides of the fluorescent tube for its continuity as shown in Fig 5. Discard the fluorescent tube with open or fused filament in either side.

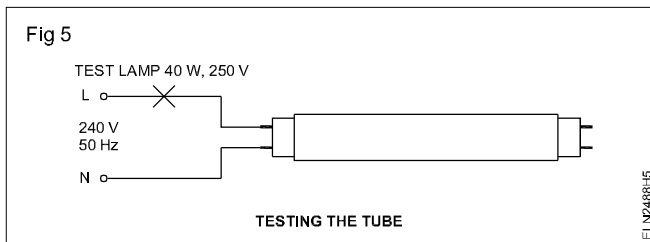

6 Fix the bulb in the holder.

Firstly, you have to make sure that the slot in the inner parts of the holder is turned to the proper position.

7 Then insert both the ends (pins) into the holder of the fittings on either side of the tube.

One end is shown in Fig 6. Push the socket pins all the way into the fittings until you feel that you can turn the tube in the sockets.

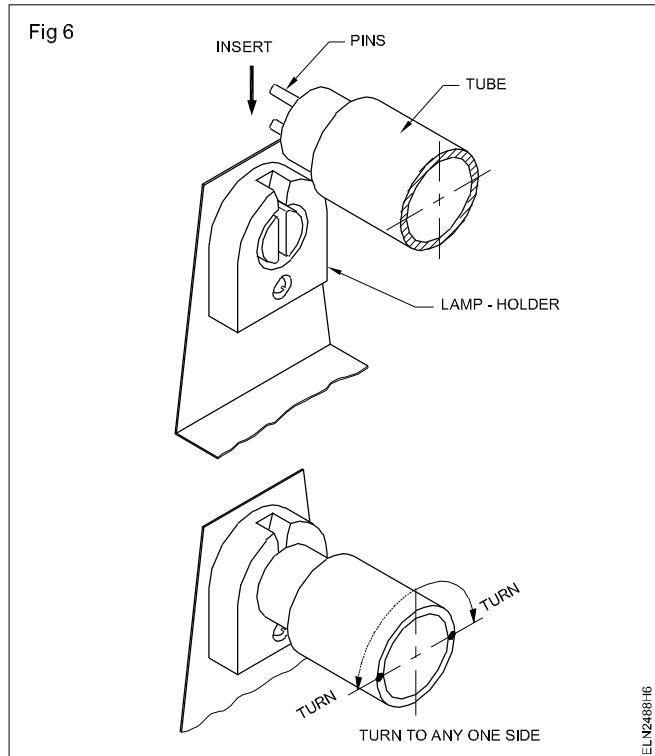

8 Turn the tube at both ends in any one direction by a quarter turn. Stop when you feel that the pins have 'snapped' into position.

Be careful not to bend the pins at either end of the tube.

9 Test the tube light assembly for its working.

TASK 2 : Installation of tube light fitting

1 Follow the recommended method and procedure depending on the type of wiring.

The fixing of the tube to the wall, ceiling or tubular post should be strong enough to support the weight of the fitting.

The installed fitting must be below the level of the ceiling fan to avoid the flickering effect of the shadow.

2 Connect the tube light fitting to the ceiling rose.

Check the supply at the ceiling rose. Switch off the supply before making any connection.

3 Fix the fluorescent tube in the fitting.

Use a stable ladder and a helper to hold the ladder while you are working on the ladder.

4 Switch 'ON' the supply and observe the glow of the tube. If the tube is not glowing, check for proper housing of starter and tube.

TASK 3 : Connect and test Instant start fluorescent lamp

- 1 Identify the accessories for an instant start fluorescent tube.
- 2 Assemble the accessories and connect as per circuit in Fig 7.

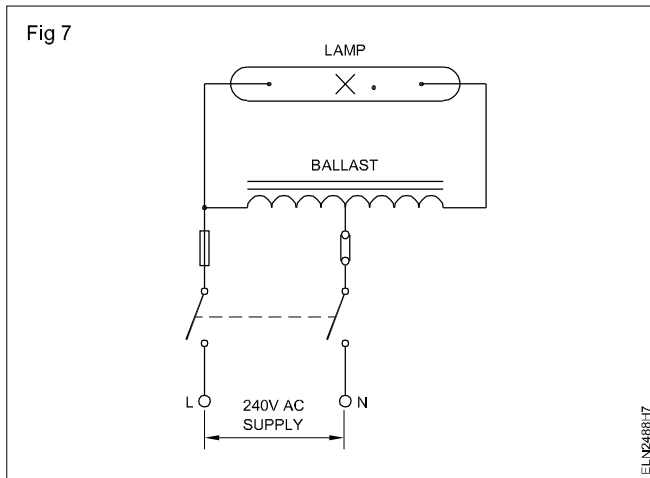

Test the ballast for insulation and confirmation of terminals.

- 3 Switch 'ON' the main supply and observe the tube.
- 4 Connect a single tube light with the starter in parallel with the instant start tube light circuit. (Fig 8)

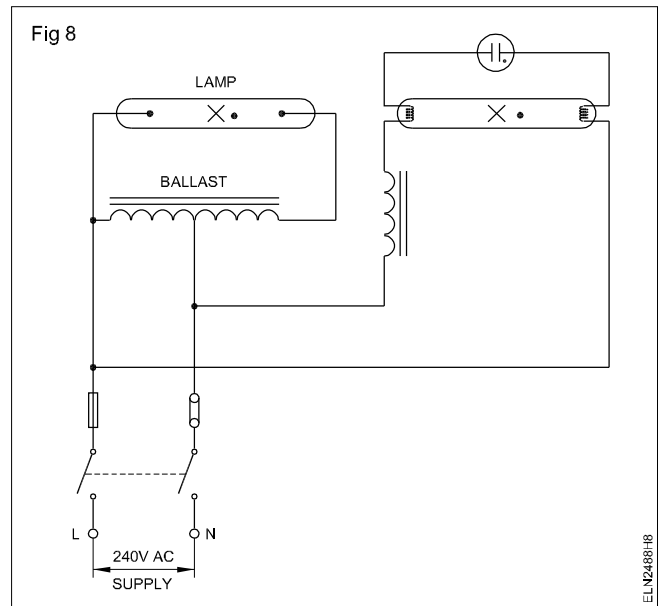

- 5 Switch 'ON' the supply and observe the starting of both the tubes. Repeat it for sufficient number of times.
- 6 Record your observation on the performance of either of the tube lights.

TASK 4 : Connect and test rapid start fluorescent lamp

- 1 Repeat the steps 1 to 3 of Task 3 for the rapid start fluorescent lamp. (Fig 9)

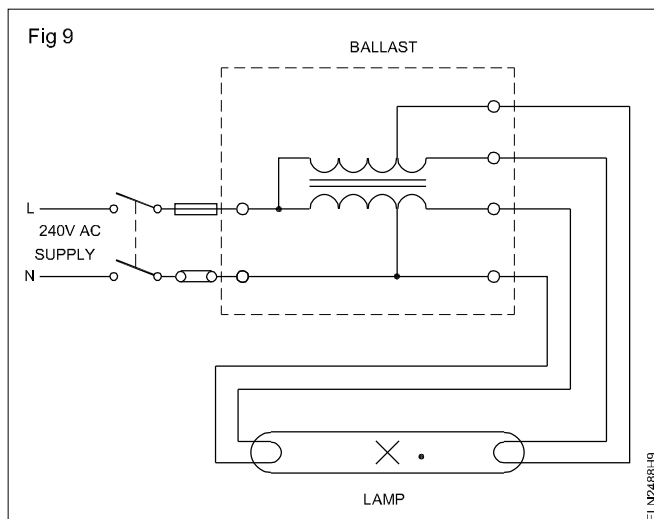

- 2 Connect the instant start tube light circuit in parallel with rapid start tube circuit. (Fig 10)

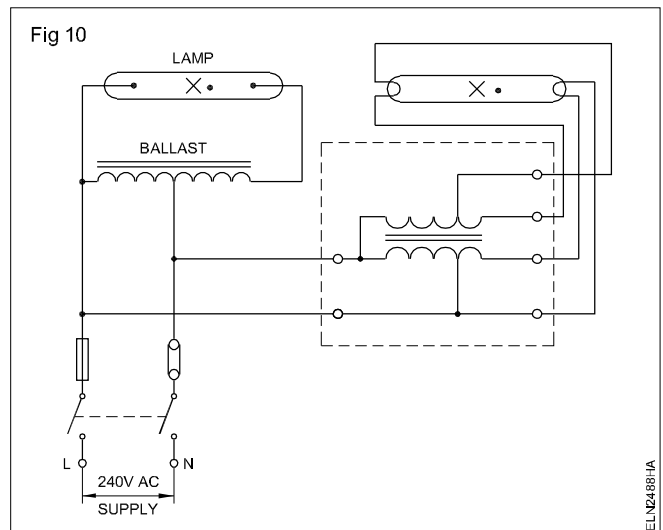

- 3 Switch on the supply and observe the starting of both the tubes.
- 4 Record your observation on the performance of either of the tubes.

TASK 5 : Install and test the H.P.M.V (High Pressure Mercury Vapour) lamp with accessories

- 1 Read the specification of the mercury vapour lamp and the choke from the markings. (Fig 11)

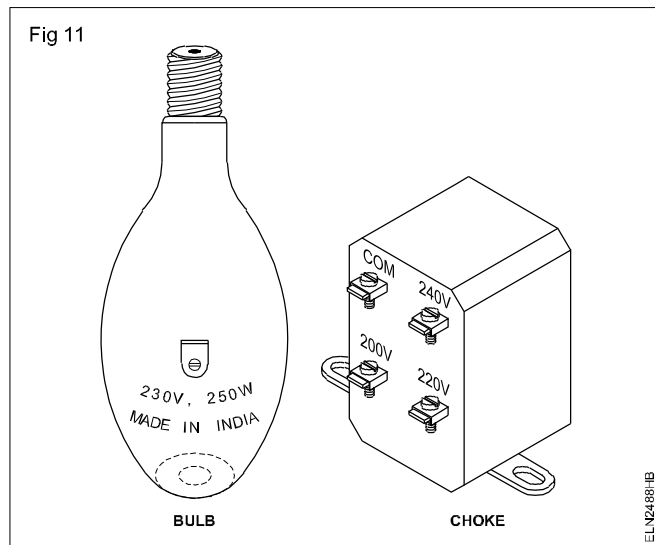

- 2 Connect the H.P.M.V. lamp in series with the 60W 240V bulb and test in 240V AC supply. Check whether the series test lamp glows.
- 3 Test the choke for its working condition.
- 4 Assemble the accessories (choke, holder and capacitor) in the fitting, following the manufacturer's instructions.
- 5 Connect the accessories as per circuit diagram, Fig 12 (Pictorial diagram Fig 13) using the recommended type of termination.

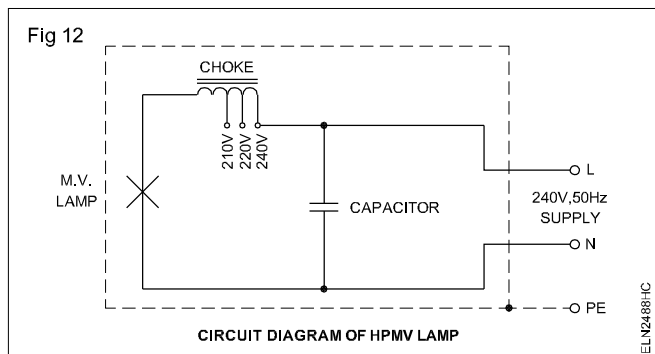

Choose the tapping of the choke suitable to the rated supply system voltage.

- 6 Fix the bulb in the holder and test the working of the lamp with the supply voltage.

Ensure the fitting is properly earthed at the earthing terminal provided, before testing.

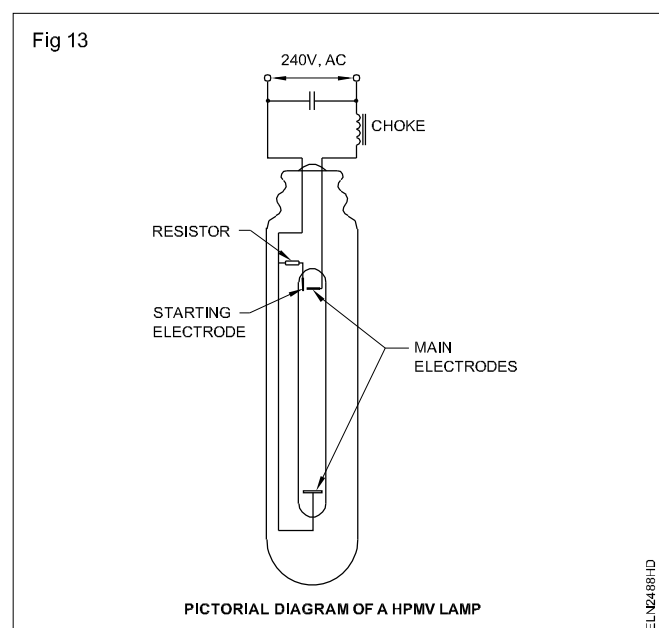

- 7 A modern M.V. lamp with a built-in resistor needs no external accessories to be connected as discussed above. It can be connected as we do an incandescent lamp.

Installation of the M V lamp fitting

- 8 Assemble, connect and test the M.V. lamp fitting on a table, for its working. Then remove the cover and bulb.

Mount at the location

- 9 Observe the recommended method and procedure specified by the manufacturer in the installation leaflet.

Do not alter the specifications recommended by the manufacturer because it should be strong enough to support the weight of the fitting.

- 10 Connect the M.V. lamp fitting to the supply. The method depends on the system of wiring, location of fitting etc.

Ensure that the supply line is dead (not live), before making the connections.

- 11 Fix the bulb in the holder securely and refit the cover.
- 12 Switch on the supply and wait until the high pressure mercury vapour lamp glows with its full brightness. then switch off the supply.

TASK 6 : Install and test H.P.S.V. (High Pressure Sodium Vapour) and LPS lamp with accessories

- 1 Read the specification from the markings on the leak transformer, choke and bulb.
- 2 Check the transformer and choke with a test lamp for shorts and open.

- Assemble the accessories (choke, leak transformer and lamp-holder) in the fitting.

Follow strictly the manufacturer's instructions.

- Give connections as per diagram shown in Fig 14

Use the recommended type of termination only.

- Choose the appropriate voltage tapping suitable to the supply voltage. (Fig 14)

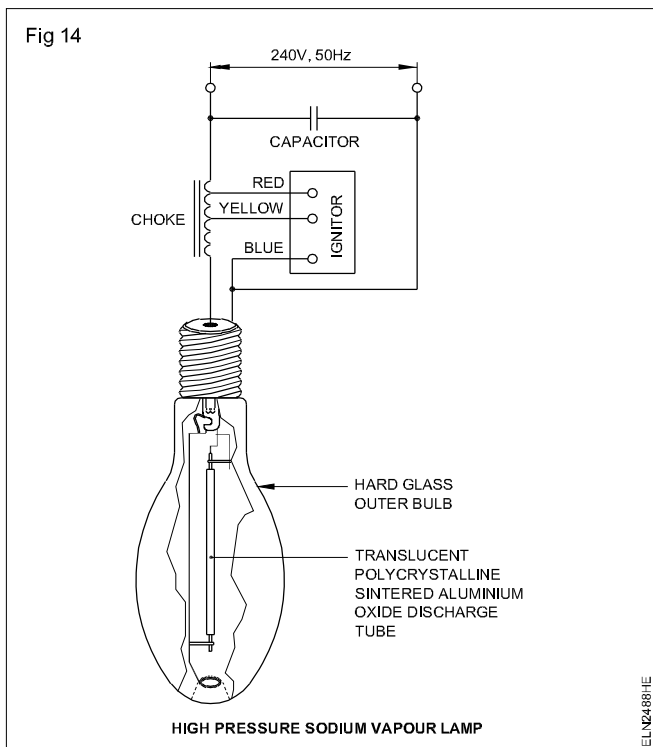

- Fix the bulb in the holder.

Ensure the fitting is properly earthed.

- Test the working of the assembled fitting by connecting it to the mains.
- Note the time taken for the bulb to give full illumination.
- Repeat the above steps for a high pressure sodium vapour lamp. Connect as per the diagram shown in Fig 15.

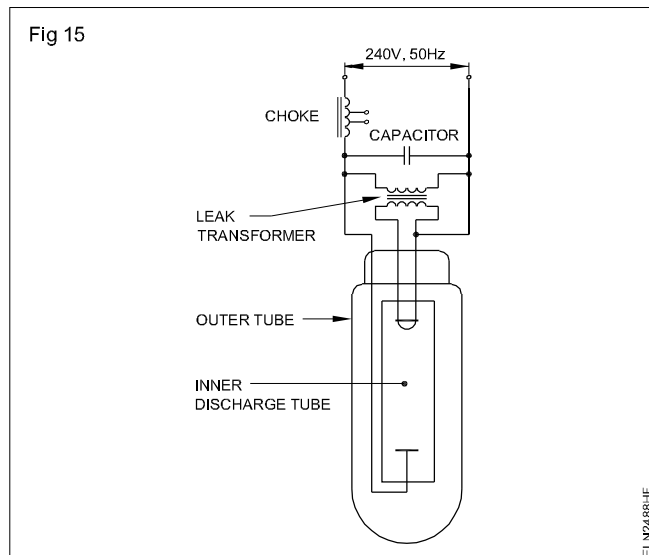

TASK 7 : Testing of High prssure metal Halide

- Read the specifications of the given Halide lamp as Fig. 16 collect the required accessories.

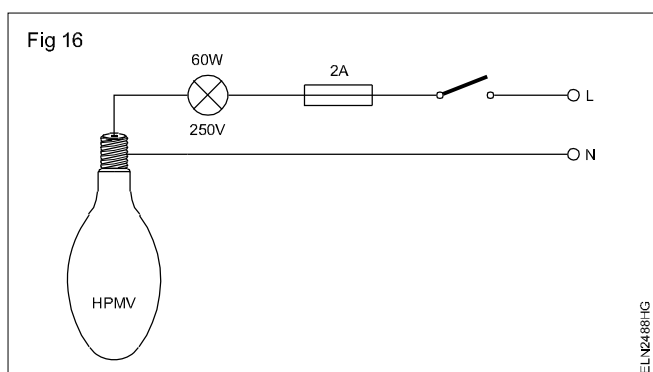

- Connect the HPMH lamp in sries with a 60W, 250V incandescent amp as shown in fig. 16 and test with

240V AC supply. Check whether the series test lamp glows. If the test lamp flows it means that HPMV lamp in good codition.

- Connect as the circuit diagram and test with 240V supply.
- Measure the current and test with 240V supply.

Measure the current and voltage. Calculate the power and verify with the rated values.

Voltage : _____ Volt

Current : _____ Amp

Power : _____ Watt

Prepare decorative lamp circuits using drum switches

Objectives: At the end of this exercise you shall be able to
 • use drum switches for decorative illumination.

Requirements		
Tools/Instruments		Materials
<ul style="list-style-type: none"> Electrician knife 100 mm - 1 No. 150 mm cutting pliers - 1 No. Heavy duty screwdriver 200mm - 1 No. Connector screwdriver 100 mm - 1 No. Hammer ball peen 1/2 kg - 1 No. 		<ul style="list-style-type: none"> T.W. Board 600 x 1200 x 25 - 1 No. Batten holders 250V/6A - 25 Nos. B.C. lamps 40W /25V - 25 Nos. Tube light holder plain - 2 Nos. PVCA 1/18 P.V.C. Copper wire - 25 Mtr. PVCA 3/20 P.V.C. Copper wire - 25 Mtr. I.C.D.P 250V / 16A - 1 No.
Equipment / Machines		
<ul style="list-style-type: none"> Fractional HP motor coupled with drum switch - 1 Set 		

1 Mark the layout of bulbs for the letters ITI as per Fig 1 on the board 60 cm x 120 cm.

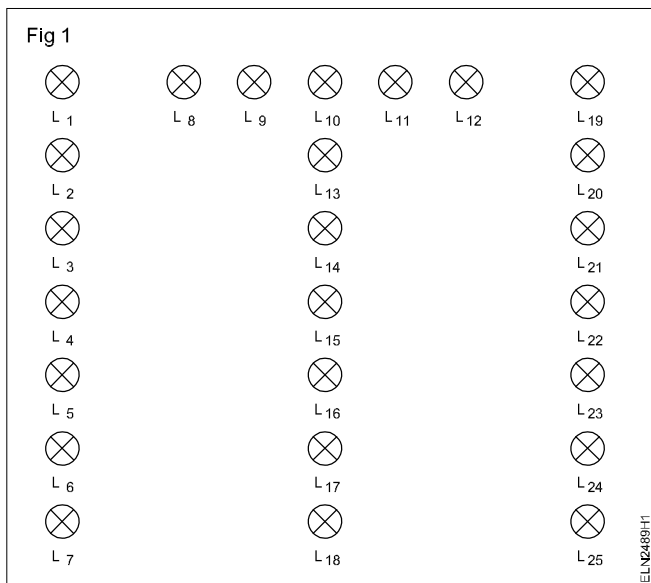

- Fix the lamp-holders (batten) on the board after making through holes for cable entry.
- Loop one terminal of each lamp-holder with cable for connection to the neutral and draw a cable up to the isolating switch.

- Connect individual cables to the other left out terminal of the lamp-holder of suitable (estimated) length for connection to the drum switch.
- Make the connections of the phase wire from each lamp to the finger strips as per the sequence indicated in Fig 2.
- Mount the drive-motor pulley on the shaft with proper tension over the drive belt. Connect the motor through a suitable starting gear. Run the motor, check for the smooth functioning of the drum switch. (Fig 2)

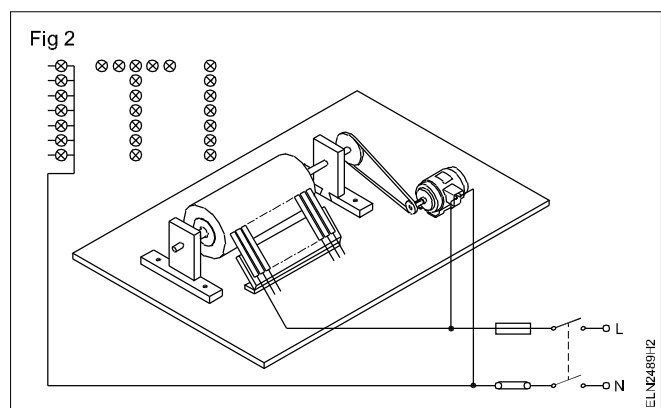

Prepare a decorative lamp circuit to produce rotating light effect/ running light effect

Objectives: At the end of this exercise you shall be able to

- select lamps/sequential control for light decoration
- design lighting layout for running light
- design layout for rotating light
- connect the motor for 3-point running light (sequential control motor)
- connect lamp circuits in the electronic sequential controller.

Requirements			
Tools/Instruments		Materials	
• Multimeter	- 1 No.	• Cams	- 3 Nos.
Equipment/Machines		• Brushes	- 3 Nos.
• Single phase motor FHP with reduction gear	- 1 No.	• Connection leads flexible	- as reqd.
• 240V operation output load 5 to 10 A with speed and intensity control	- 2 Nos.	• Cam drive arrangement with shaft	- 1 No.
		• Lamps 240V, 15W, BC	- 54 Nos.
		• Batten Lamp holder 6A, 250 V	- 54 Nos.
		• DPST knife switch 16A 250V	- 2 Nos.
		• Electronic sequential controller	- 1 No.

PROCEDURE

TASK 1 : Prepare a rotating

- 1 Connect the lamps, switches and the flasher motor. (Fig 1).
- 2 Keep the D.P.S.T switches S_1 & S_2 Open.
- 3 Close the D.P.S.T switch S_1 and start the flasher motor (sequential light controller).
- 4 Close the D.P.S.T Switch S_2 and observe the make and break contacts 1,2,3 and "ON" "OFF" operations of the 3 lamp banks.

Do not touch live wires

- 6 Open the D.P.S.T. switch S_1 and S_2

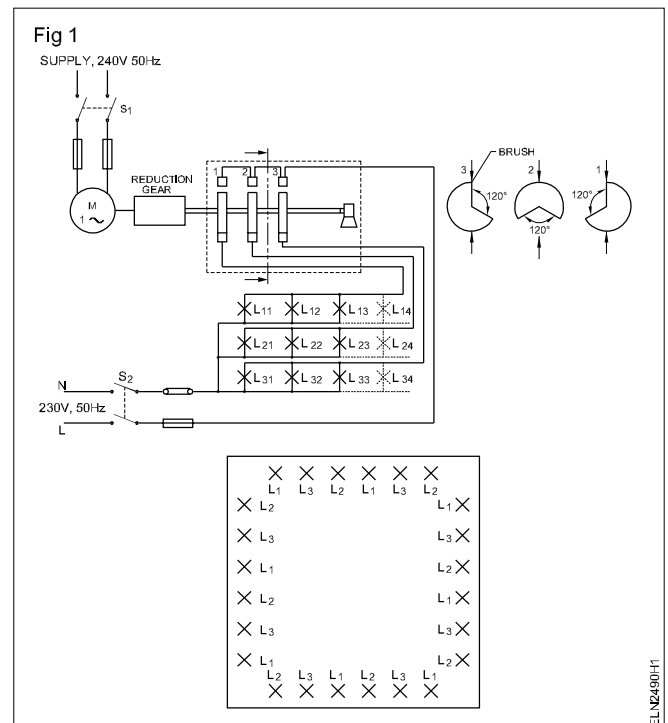

TASK 2 : Prepare a running light effect

- 1 Prepare the lighting design as shown in Fig 2.
- 2 Close the D.P.S.T. switch S_1 and observe the lighting.
- 3 Increase the speed of operation by operating the speed control.
- 4 Adjust the intensity of light-adjusting the knob on the electric sequential controller.
- 5 Reduce the speed and intensity of the lighting system.
- 6 Open the D.P.S.T. switch S_1 .

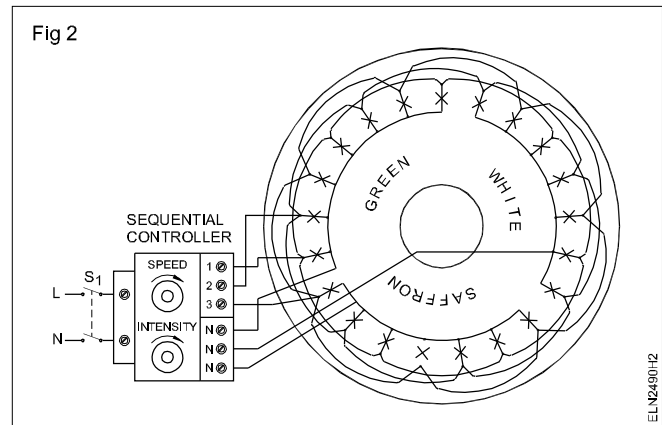

Install light fitting for show case lighting

- Objectives:** At the end of this exercise you shall be able to
- install and wire up the show case window lighting for tie rack
 - wire up a show case window lighting to display clothes.

Requirements	
<p>Tools and Instruments</p> <ul style="list-style-type: none"> • Insulated cutting pliers 150 mm - 1 No. • Screw driver set of five - 1 Set • Line tester 500V - 1 No. • Electric hand drilling machine 6 mm capacity - 1 No. 	<p>Materials</p> <ul style="list-style-type: none"> • Complete set of circline tube light 30 cm 32 watts 250V 50 Hz with suitable shade and stand - 1 No. • Complete set of 1200 mm fluorescent lamp fitting 40 watts 250V 50 Hz - 4 Nos. • Wiring materials - as reqd.

PROCEDURE

TASK 1 : Install and wire up the show case window lighting for tie rack

- 1 Place a suitable sized plywood board in the base of the window with spacers.
- 2 Locate the circline tube fitting with its stand in proper position in the show case so that complete stand is visible from the window. Refer Fig.1.
- 3 Wire up in such a way that a 3 pin 5 amps socket is fitted in the inner side of the window.
- 4 Mark the position of stand base and drill a hole in the marked centre to allow the circline tube cable to pass.
- 5 Draw the cable through the hole and connect a 3 pin plug at the cable ends.
- 6 Check the connections and connect the plug to the socket.
- 7 Give supply and check the lighting for the tie rack.

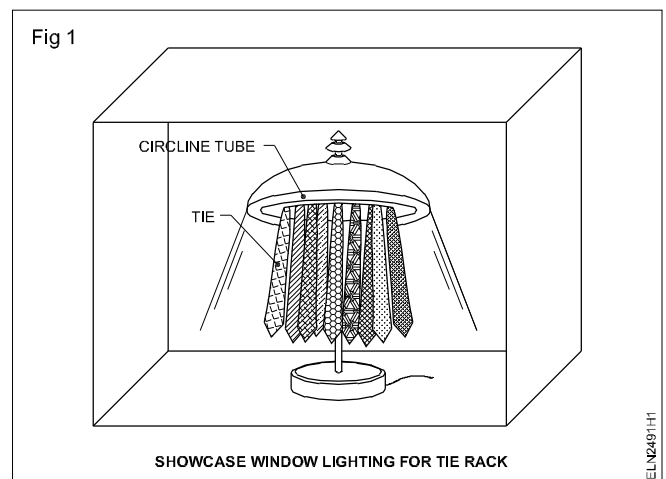

TASK 2 : Wire up the show case window lighting for a mannequin (dummy figure used for to display clothes)

The show case needs four (400mm) tube light fittings to be wired in parallel and the tubes are hidden behind the frame. Refer Fig 2. Draw the connection diagram and wire up the fluorescent tubes in concealed wiring.

- 1 Prepare suitable frame for 4 tube light fittings which are to be hidden behind the frame (Fig 2)
- 2 Draw the connection diagram and wireup the 4 tube lights in parallel.
- 3 Place the dummy figure at the centre used to display the clothes
- 4 Get the supply and check for its functioning.

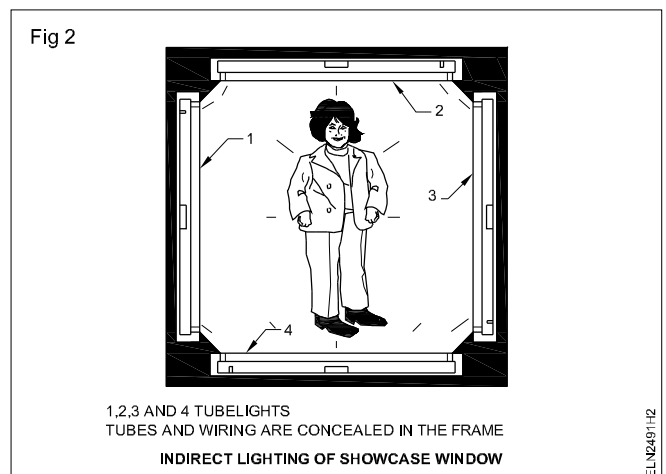

Practice on various analog and digital measuring instruments

Objectives: At the end of this exercise you shall be able to

- connect various analog measuring instruments and measure Power parameters
- connect various digital measuring instruments and measure Power parameters.

Requirement			
Tools / Instruments		Equipment / Machines	
• MI voltmeter 0 - 500V (analog)	- 1 No.	• Squirrel cage Induction motor	
• Digital voltmeter 0 - 500V	- 1 No.	3 phase, 440V, 5 HP	- 1 No.
• MI ammeter 0 - 30A (analog)	- 1 No.	Materials	
• Digital ammeter 0 - 30A	- 1 No.	• Connecting leads	- as reqd.
• Power factor meter 0.5 lag - 1 - 0.5 lead (Analog)	- 1 No.	• TPIC switch 16A, 500V	- 1 No.
• Digital power factor meter	- 1 No.		
• Analog wattmeter 0-1500W	- 1 No.		
• Digital wattmeter 0-1500W	- 1 No.		
• Analog frequency meter 45-55HZ	- 1 No.		
• Digital frequency meter 45-55HZ	- 1 No.		

PROCEDURE

TASK 1: Measure the value of current, voltage, power factor, power and frequency by connecting respective analog meters in the circuit

- 1 Identify the analog type of voltmeter, ammeter , wattmeter power factor meter and frequency meter from the given Figure Nos. 3 to 13.
- 2 Verify the range of analog voltmeter, ammeter wattmeter, powerfactor meter and frequency meter.
- 3 Connect the power supply with switch, fuse, analog meters and load as shown in Fig 1
- 4 Close the switch
- 5 Measure the corresponding values from the instruments and record the values in Table 1.
- 6 Switch off the Power Supply and disconnect the connection.

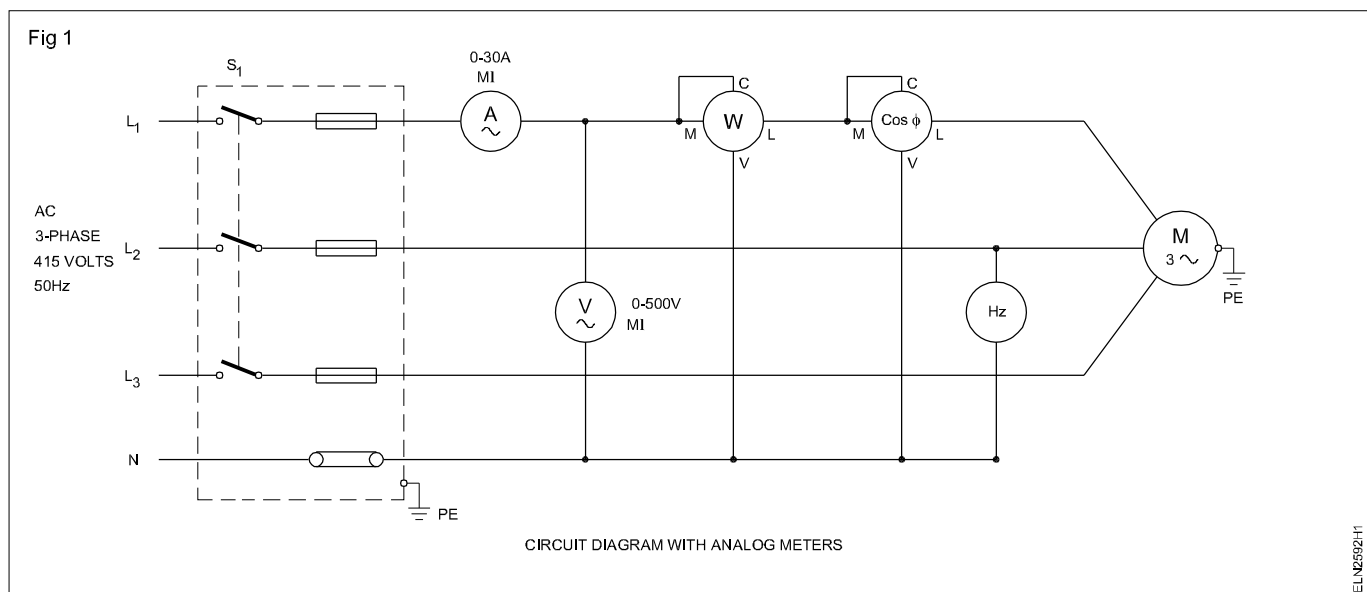

Table 1

SI. No.	Meter	Reading
1	Voltmeter	
2	Ammeter	
3	Watt meter	
4	Power factor meter	
5	Frequency meter	

TASK 2 : Measure the value of current, voltage, power factor, power and frequency by connecting respective digital meters in the circuit

- 1 Identify the digital type of voltmeter, ammeter, wattmeter, power factor meter and frequency meter from the given figure nos. 3 to 13.
- 2 Verify the range of digital voltmeter, ammeter, wattmeter, power factor meter and frequency meter.
- 3 Connect the power supply with switch, fuse, digital meters and load as shown in Fig 2
- 4 Close the switch.
- 5 Measure the corresponding values from the instruments and record the values in Table - 2
- 6 Switch off the power supply and disconnect the connection.

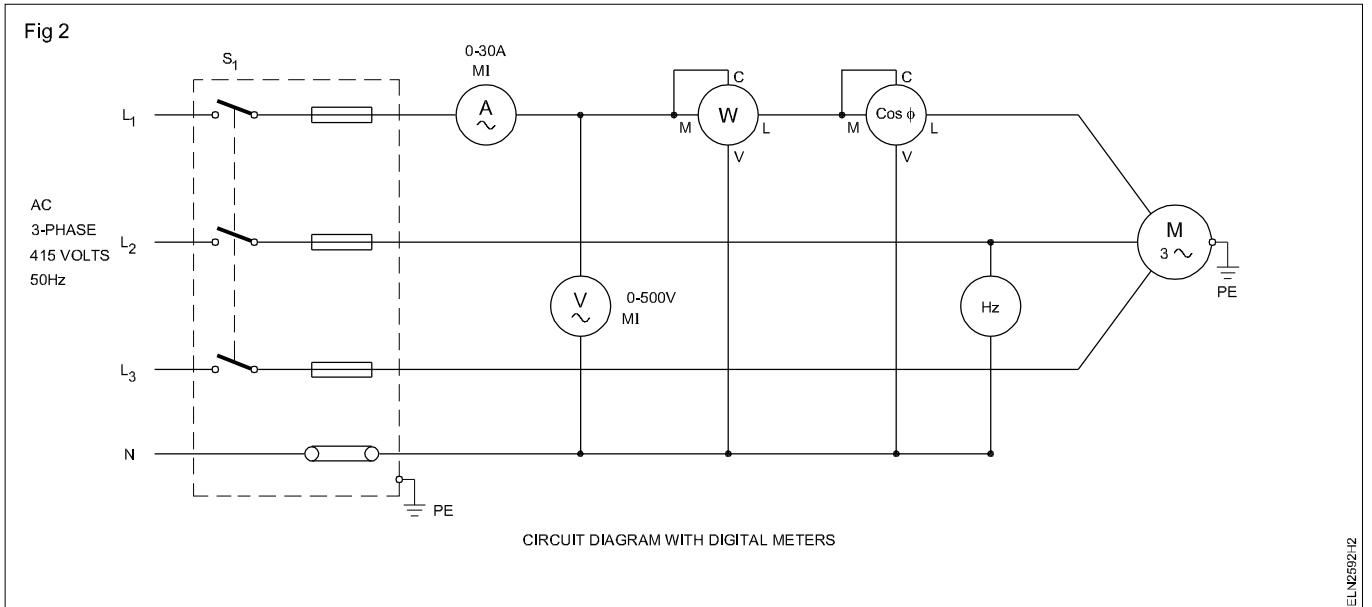

Table 2

SI. No.	Meter	Reading
1	Voltmeter	
2	Ammeter	
3	Watt meter	
4	Power factor meter	
5	Frequency meter	

Fig 3

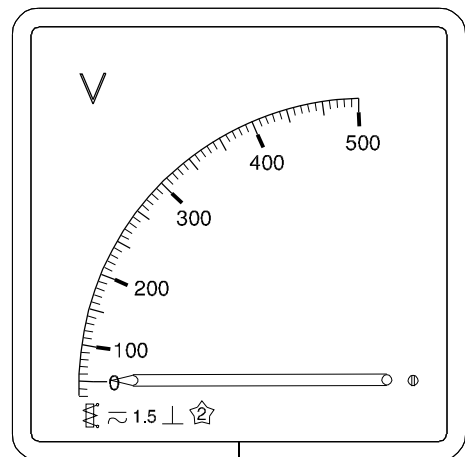
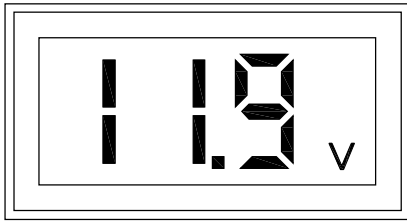

Fig 4



DIGITAL VOLT METER

ELN2592H4

Fig 7

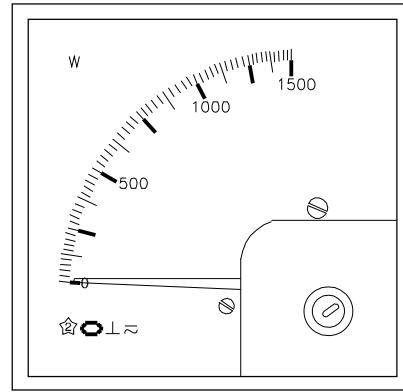

ANALOG WATT METER

ELN2592H7

Fig 5

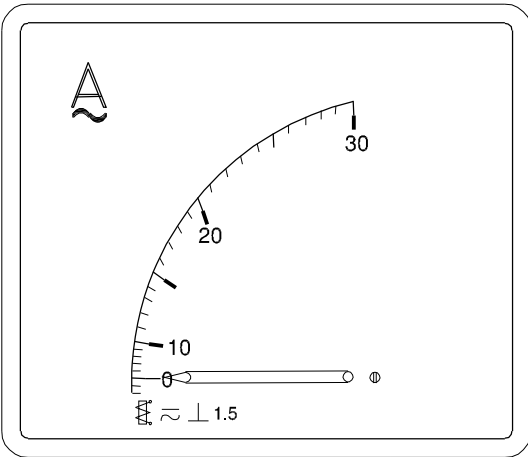

ANALOG AMMETER

ELN2592H5

Fig 8

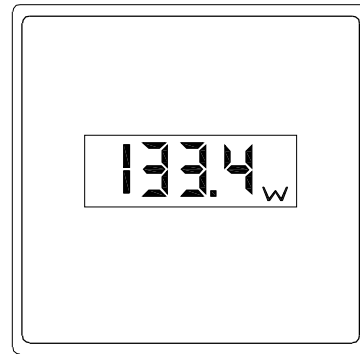

DIGITAL WATT METER

ELN2592H8

Fig 6

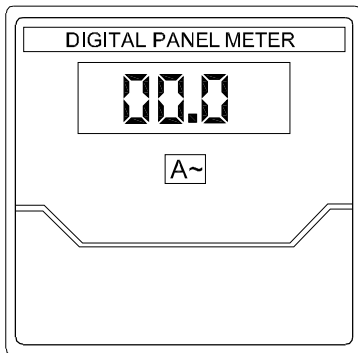

DIGITAL AMMETER

ELN2592H6

Fig 9

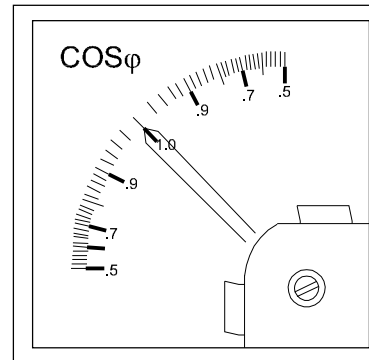

ANALOG POWER FACTOR METER

ELN2592H9

Fig 10

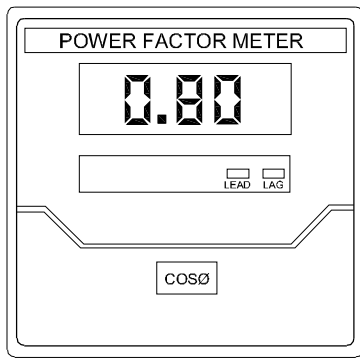

DIGITAL POWER FACTOR METER

ELN2592HA

Fig 12

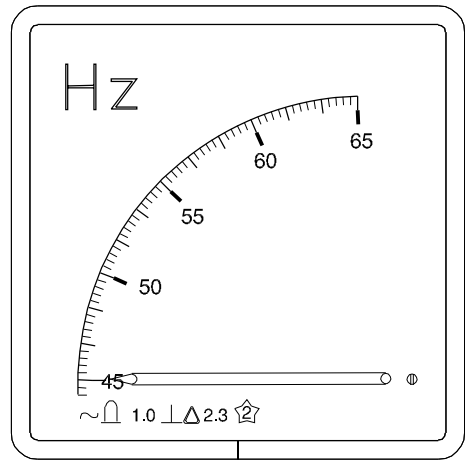

ANALOG FREQUENCY METER

ELN2592HC

Fig 11

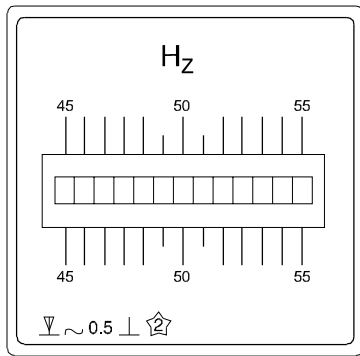

FREQUENCY METER

ELN2592HB

Fig 13

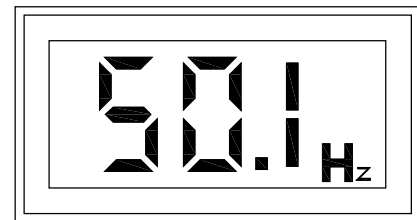

DIGITAL FREQUENCY METER

ELN2592HD

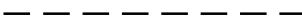

Practice on measuring instrument in single and three phase circuit eg. multimeter, wattmeter, energy meter, phase sequence and frequency meter etc.

Objectives : At the end of this exercise you shall be able to

- connect voltmeter, ammeter, wattmeter, energy meter, frequency meter and power factor meter in single phase load
- connect voltmeter, ammeter, wattmeter, energy meter, frequency meter, power factor meter and phase sequence indicator in 3 phase balance load
- measure voltage, current, power, energy, frequency, power factor and record the values
- connect phase sequence meter to find the phase sequence.

Requirement	
<p>Tools/Instruments</p> <ul style="list-style-type: none"> • Electrician Tool kit- 1 Set • MI volmeter 0 - 300 v - 1 No. • MI Ammeter 0 - 5 A - 1 No. • wattmeter AC 0 - 1500 W - 1 No. • Energy meter 3ϕ 4 15V - 1 No. • power factor meter 0 -5 leg-1 - 1 No. • Frequence of meter 0 - 50 Hz led - 1 No. 	<p>Equipment / Machines</p> <ul style="list-style-type: none"> • Lamp load 1000W - 1 No. <p>Materials</p> <ul style="list-style-type: none"> • Fuse carrier - 5A - 1 No. • DPIC Switch 16A, 250v - 1 No. • 14 SWG copper wire - 0.5 kg. • Insulation tape 25 mm of 5 m - 1 roll • 1.5 mm² pvc copper wire - 5 m • TPIC switch 16A - 1 No.

PROCEDURE

TASK 1 : Connect voltmeter, ammeter, wattmeter single phase energy meter, power factor meter and frequence meter in single phase circuit

- 1 Collect the required materials, meters and load.
- 2 Make necessary connections with meters and load as per circuit diagram (Fig 1)

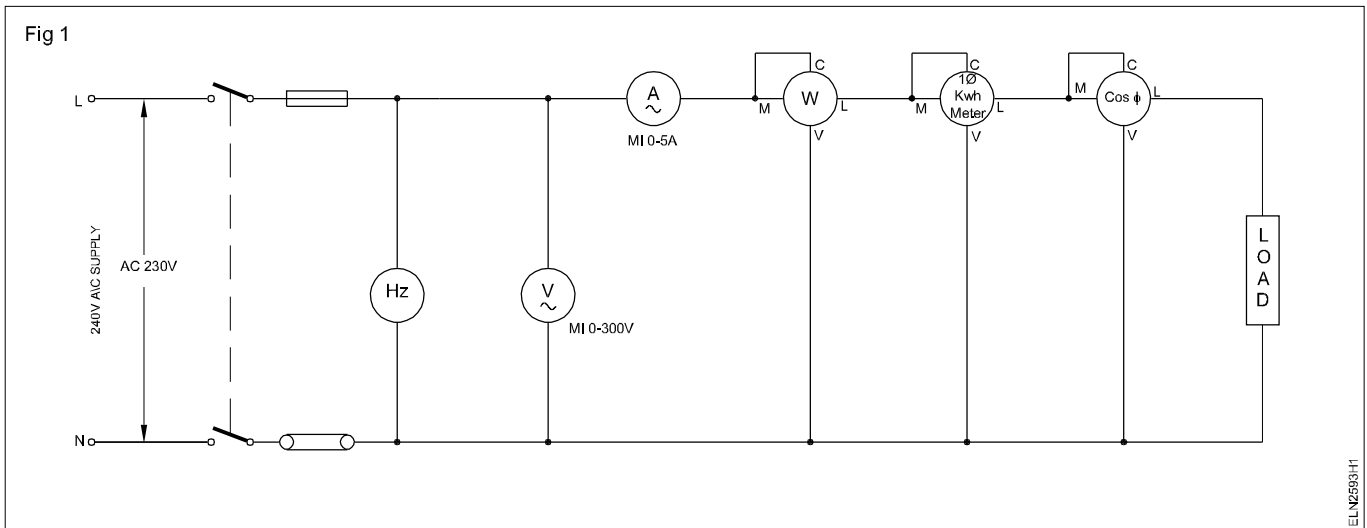

The current coil of the wattmeter, energy meter and P.F meter must be connected in series with load. Provide 5 Amps fuse in the fuse carrier.

- 3 Get the circuit approved by the instructor.

- 4 Switch 'ON' the power supply and observe deflections of the meters.

If the wattmeter shows reverse direction interchange the connection of current coil

5 Note down the meter readings and enter in Table 1.

6 Switch "OFF" the power supply and disconnect the connection.

Table 1

Sl. No.	Ammeter reading (Amps)	Voltmeter reading (volts)	Wattmeter reading (watts)	Frequency meter (Hz)	Power factor meter (Cos ϕ)	Energy meter (kwh)

TASK 2 : Connect voltmeter, ammeter, wattmeter, energy meter, frequency meter, power factor meter and phase sequence indicator in 3 phase circuit

- 1 Collect the required materials, meters and load.
2. Make necessary connections with meters and load as per circuit diagram (Fig - 2)

- 4 Switch 'ON' the power supply and observe deflections of the meters.

The current coil of the wattmeter, energy meter and P.F. meter must be connected in series with load. Provide 5 amps fuse in the fuse carrier.

If the wattmeter shows reverse direction interchange the connection of current coil.

- 3 Get the circuit approved by the instructor.

- 5 Find out the phase sequence of the 3 phase supply.
- 6 Note down the meter reading and enter in Table - 2.
- 7 Switch 'OFF' the power supply and disconnect the connection.

Table 2

Sl. No.	Ammeter reading (Amps)	Voltmeter reading (volts)	Wattmeter reading (watts)	Frequency meter (Hz)	Power factor meter (Cos ϕ)	Energy meter (kwh)	Phase sequence RY B / R BY

Fig 2

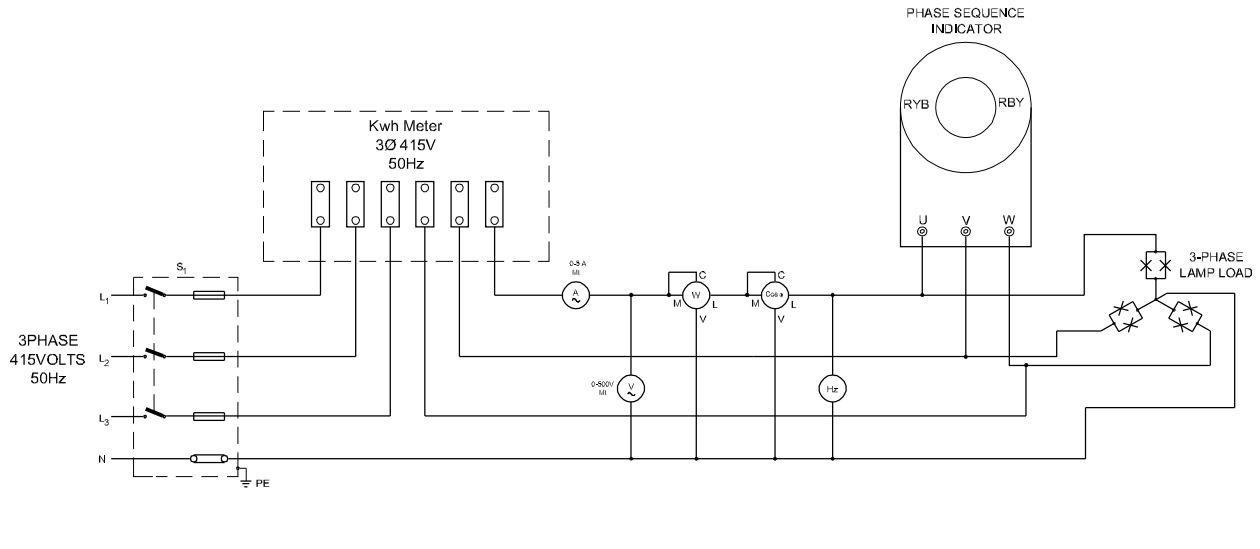

ELN2593H2

Measure the power in 3-phase circuit using two wattmeter methods

Objectives : At the end of this exercise you shall be able to

- connect two wattmeters in the circuit as per the given diagram
- measure the power and calculate the power factor.

Requirements			
Tools / Instruments		Materials	
• Wattmeter 500V/5A, 3 KW	- 2 Nos.	• 200W, 250V lamps	- 3 Nos.
• M.I. Voltmeter 0-500 V	- 1 No.	• 100W, 250 lamps	- 3 Nos.
• M.I. Ammeter 0-5A	- 1 No.	• Connecting leads	- as reqd.
Equipment / Machines		• Pendant-holders 6A 250V	- 6 Nos.
• 3-phase, 415V AC induction motor 3 HP	- 1 No.		

PROCEDURE

TASK 1 : Measure the power in 3 phase circuit using two wattmeter method and calculate power factor

- 1 Form the circuit as per the given circuit diagram. (Fig 1)

Connect proper ranges of meters suitable for the given load.

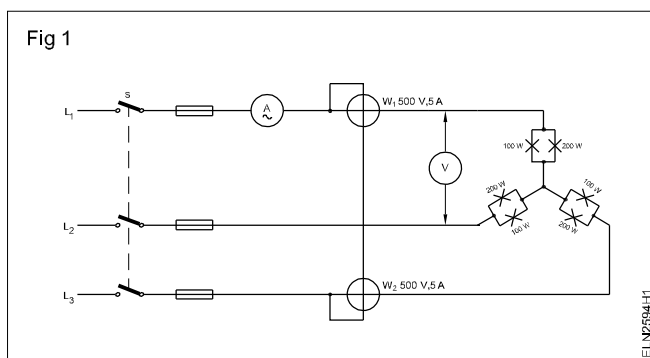

- 2 Switch 'ON' the 3-phase supply and observe for the proper deflection of wattmeters. If both wattmeters deflect properly, go to step 4, otherwise continue from step3.
- 3 Switch 'OFF' the supply, if any one wattmeter deflects in the reverse direction. Change the connection of the potential coil of the reverse deflection wattmeter. Go to step 5.

- 4 Read wattmeters W_1 & W_2 and record in Table 1. Add the readings W_1 and W_2 and record the total power; go to setp 6.
- 5 Switch on the supply and read the wattmeters W_1 & W_2 . Record the values in the Tables. Record the readings of the wattmeter with the changed potential coil as negative quantity.
- 6 Measure the 3-phase power for different load conditions specified below :
 - a $L_1 = 300$ W bulb
 $L_2 = 300$ W bulb
 $L_3 = 300$ W bulb
 - b L_1, L_2, L_3 water load to take a current of max. 3 amps
 - c Induction motor 3 HP on no load
 - d Induction motor 3-HP with load

The instructor personally to connect the three-phase motor for proper running.

- 7 Calculate the power factor in all the above cases and enter them in Table 1.
- 8 Get your work checked by Instructor.

Table - 1

Type of Load	Wattmeter W_1	Wattmeter W_2	Total $W_1 + W_2$	Calculated Power factor Cos θ	
				Tan $\theta = \sqrt{3} \left[\frac{W_1 - W_2}{W_1 + W_2} \right]$	Cos θ
1					
2					
3					
4					
5					

Conclusion: _____

Measure power factor in three phase circuit by using power factor meter and verify the same with voltmeter, ammeter, wattmeter readings

Objectives: At the end of this exercise you shall be able to

- connect a single phase P.F. meter in 3-phase balanced load and read the P.F
- verify the P.F. by voltmeter, ammeter and wattmeter readings and determine the error
- connect the capacitor bank in the 3-phase circuit and measure the P.F.

Requirements

Tools / Instruments

- Single phase P.F. meter 250V/ 500V; 5A/ 10A - 1 Set
- Wattmeter 250/500V, 5A/10A 1500W - 1 Nos.
- M.I Ammeter 0-5 A/ 10A - 1 No.
- M.I Voltmeter 0-300V/ 600V - 1 No.
- Insulated combination plier 200mm - 1 No.
- Insulated screwdriver 200mm - 1 No.

Equipment / Machines

- 3-phase induction motor 415V 2.25 KW (with loading arrangement) - 1 No.
- Power factor improving capacitor bank single phase 250V, 50 Hz 1kvar - 1 Set
- 3 Phase lamp load 3 KW 415 V 50 Hz - 1 No.

Materials

- PVC insulated copper cable 2.5 sq. mm 650 V - grade - 20 m
- T.P.I.C. switch 16A, 500V - 2 Nos.

PROCEDURE

- 1 Collect the meters and the 3-phase lamp load.

The lamp load should have equal wattage in all the three phases.

- 2 Make necessary connections of the meters and load as per circuit diagram - Fig 1.

Connect the current coils of wattmeter and P.F. meter in series with load.

- 3 Get the circuit approved by the instructor.
- 4 Switch 'ON' the power supply momentarily observe deflections of all the meters. Keep the switch closed if nothing is abnormal.
- 5 Equally load all the three phases and note down the meter readings and enter in Table 1.
- 6 Switch 'OFF' the power supply.

Fig 1

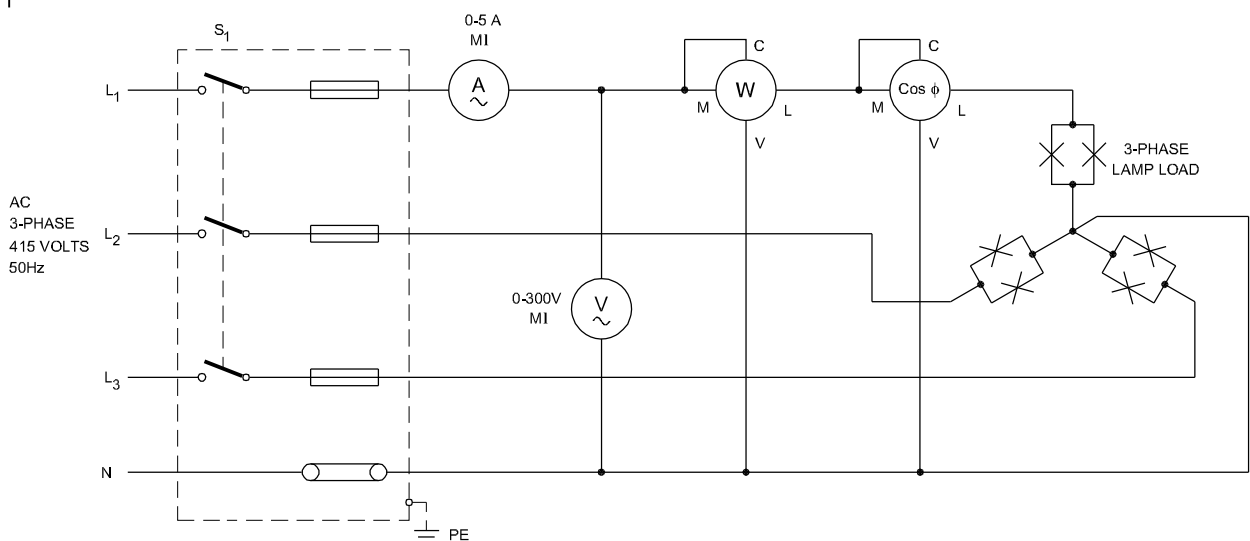

ELN2595H1

Table 1

Load condition	Ammeter reading in Amps. (I_{ph})	Volt-meter reading in Volts (E_{ph})	3-phase apparent power in watts $3 \times E_{ph} \times I_{ph}$	Wattmeter reading in Watts W	3-phase power $W \times 3$	Calculated value of P.F. $P.F. = \frac{W \times 3}{3 \times E_{ph} \times I_{ph}}$	P.F. measured value	Remarks
Resistive load								
Motor without load								
Motor without load but with capacitor								
Motor with load								
Motor with load and with capacitor								

If P.F. meter shows leading P.F. for inductive load, switch 'off' the supply and interchange current coil connections of the P.F. meter.

7 Determine the power factor by using the formula,

$$P.F. = \frac{W \times 3}{3 \times E_{ph} \times I_{ph}}$$

Where W- Wattmeter reading (power in one phase)

E_{ph} - Phase voltage

I_{ph} - Phase current (Also equal to line current)

8 Compare the calculated power factor and power factor meter reading and write your observation.

Observation _____

9 Show the readings to your instructor for approval.

10 Disconnect the lamp load and connect the 3 phase induction motor with P.F. improving capacitor as shown in Fig 2.

11 Ensure that the range of current coil in wattmeter and P.F. meter are well higher than the load current of the connected load.

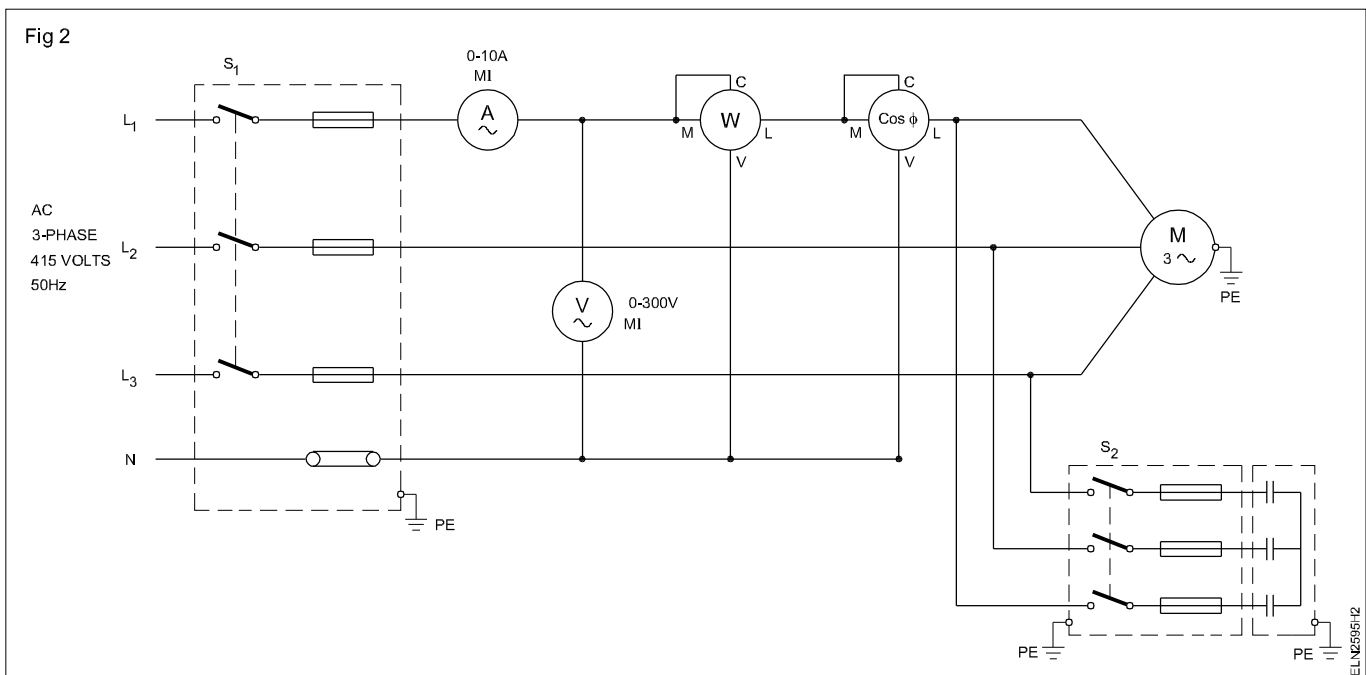

- 12 Keep the capacitor switch in OFF condition. Switch ON the power supply and observe the deflection of the meters.
- 13 Record the meter readings in Table 1 for the load conditions shown in Table 1.
- 14 Switch 'OFF' the power supply and disconnect the connection.
- 15 Calculate the power factor in each case and compare with the measured P.F.

- 16 Observe the P.F. each load condition and write your observations.

Observation _____

- 17 Show the readings and observation to your instructor for approval.

Consider the multiplying factor of the wattmeter which depends on the range of watt meter with respect to current and voltage ranges and C.C. and P.C. range selected. The reading of the wattmeter should be multiplied with the multiplying factor to get the actual power.

Measure Power parameters using tong tester in three phase circuit

Objectives: At the end of this exercise you shall be able to

- select a suitable range in tong testers to measure the different Power parameters
- measure the AC volt, DC volt and frequency
- measure the AC and DC current
- measure kw, KVA, PF and phase angle in AC circuit
- measure resistance
- measure capacitance
- measure AC and DC micro ampere.

Requirement			
Tools / Instruments		Equipment / Machines	
• Tong - tester	- 1 No.	• Single phase lamp load	- 1 Set
		• Welding Transformer	- 1 No.
		• 3 phase Induction motor 3 HP 440V, with suitable load	- 1 Set

PROCEDURE

TASK 1 : Measure the AC and DC voltage and frequency

The operating instruction given below is for one particular tong Tester. Some other model Tong Testers are also be available in market. Follow the operating instructions accordingly

- 1 Set the rotary switch to the 'V' Position.
- 2 Insert the test leads into the input Jack (Black to COM and Red to V)
- 3 Connect the test leads in parallel to the measured circuit.
- 4 The meter will automatically switch to ACV or DCV display.
- 5 The meter will automatically select the appropriate range.
- 6 Read the voltage and frequency values displayed on the LCD and note down in Table (Fig 1)

TASK 2 : Measurement of current in AC circuit

- 1 Set the rotary switch to the 'A' position.
- 2 Press the trigger to open the jaw and fully enclose the conductor to be measured.
- 3 The clamp will automatically select the appropriate range
- 4 Read the current values displayed on the LCD and note down in Table (Fig 1).

No gap is allowed between the two half Jaws

TASK 3 : Measurement of AC kW, KVA, PF and ∅ (phase angle)

- 1 Set the rotary switch to the KW / KVA Position
- 2 Insert the test leads into the input Jack. (Black to COM and Red to V)
- 3 Connect the Black lead COM to the neutral line.
- 4 Connect the Red lead 'V' to power line and clamp the same conductor where V (red) terminal is connected.
- 5 The power clamp will automatically select the appropriate range.
- 6 Read the watt and HP values displayed on the LCD and note down in Table.
- 7 Press range button to display required parameters.
- 8 For 3 phase 3 wire balanced load system, insert 3 plug in adapter in terminals "COM" and "V". Connect three crocodile clips to appropriate phase (R, Y and B)
3 phase power = 3 x meter indication (Fig 1).

$$PF = \frac{KW}{KVA} = \cos\theta$$

TASK 4 : Measurement of Resistance

- 1 Before taking resistance measurement, make sure the circuit is not live and discharge any capacitor present in the circuit.
- 2 Set the rotary switch to the Ω or $M \Omega$ range.
- 3 Insert the test leads into the input jack.
(Black to com and red to Ω)
- 4 Connect the test leads to the circuit being measured and read the displayed value.
- 5 Note down the reading in Table.

TASK 5 : Measurement of capacitance

- 1 Insert the test leads into the input Jacks (Black to COM and Red to
- 2 Set the rotary switch to the “ $\text{—}||$ ” Positon.
- 3 Connect the rotary test lead to the anode side and black test lead to the cathode side of the capacitor being tested
- 4 Read capacitance value on LCD and note it in Table.

TASK 6 : AC + DC Micro Ampere measurement

- 1 Set the rotary switch is “ $\approx \mu A$ ” position.
- 2 Insert the test leads into the input Jack (Black to COM and Red to μA) (Fig 1)
- 3 Connect the meter in series the with the circuit being measured and read the displayed value and note down the reading in Table.

Table

SI. No.	Measurement	Reading 1	Reading 2
1	AC voltage		
2	DC voltage		
3	Frequency		
4	KW		
5	KVA		
6	PF		
7	Phase angle		
8	Resistance		
9	Capacitance		
10	AC Micro Ampere		
11	DC mircro Ampere		

Fig 1

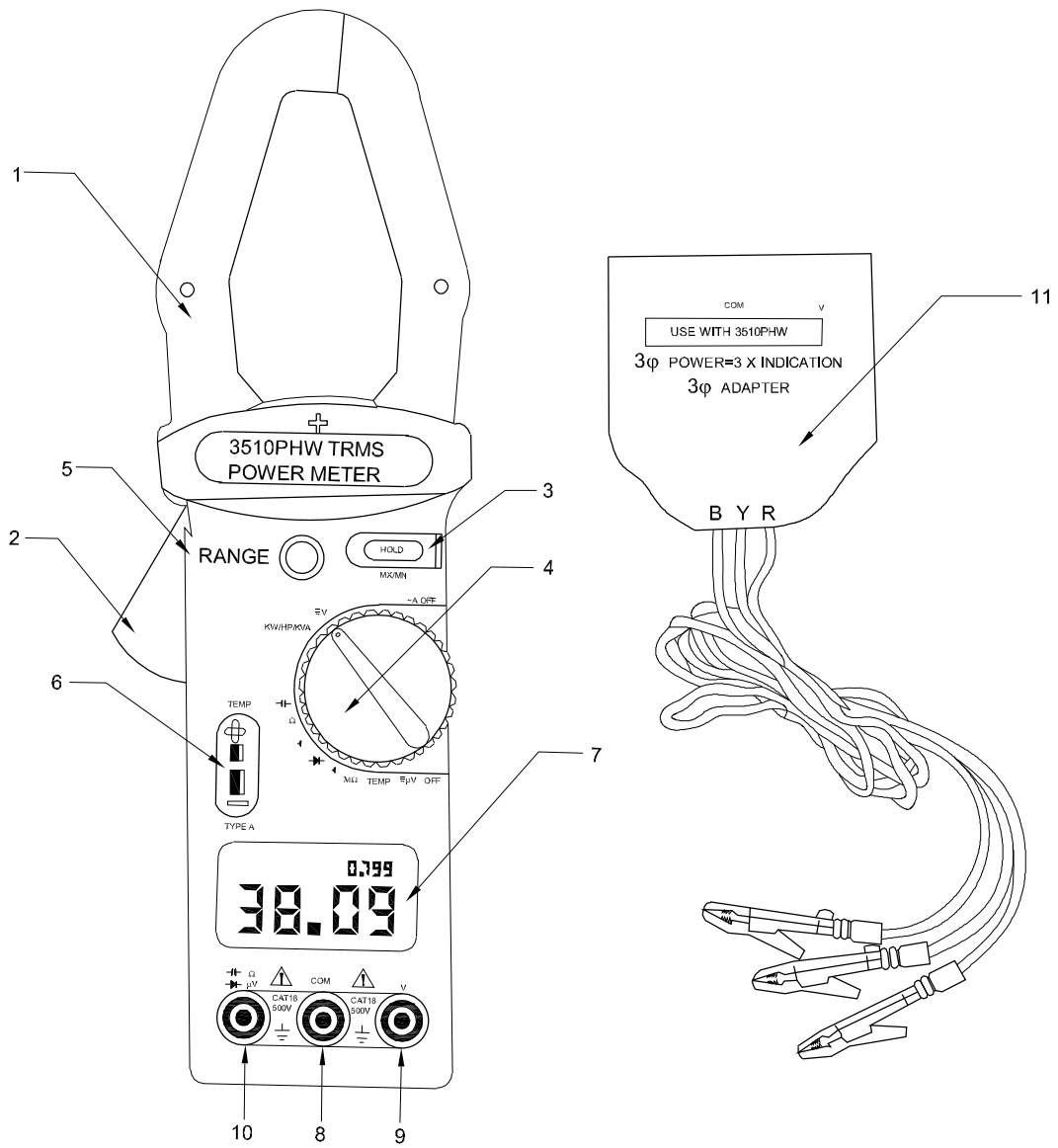

TONG-TESTER

ELN2596/H1

Practice for range extension and calibration of various measuring instruments

- Objectives:** At the end of this exercise you shall be able to
- extend MC 0-15V voltmeter range to MC 0-30V voltmeter
 - extend MC 500 milli ammeter range to MC 2.5 ampere
 - extend MC 500 milli ammeter range to MC5 ampere
 - extend MC 100 milli ammeter range to MC1 ampere
 - calibrate MC 0-50V voltmeter
 - calibrate MI 0-300V voltmeter
 - calibrate MC 0-500 m.A. ammeter
 - calibrate MI 0-1 A ammeter.

Requirements	
<p>Tools / Instruments</p> <ul style="list-style-type: none"> • Electrician's Tool Kit - 1 Set • Combination pliers 150mm - 1 No. • Wire stripper 150 mm - 1 No. • Electric soldering iron 230V 35W - 1 No. • MC milli voltmeter 0-50mV - 2 Nos. • MC milli ammeter 0-10mA - 1 No. • M C Voltmeter 0-15V - 1 No. • MC Ammeter 0-500 m.A - 1 No. • MC Voltmeter 0-100 m V - 1 No. • MC Voltmeter 0-1V - 1 No. • Ohmmeter or multimeter - 1 No. • MC Voltmeter 0-50V - 1 No. • Digital Voltmeter - 1 No. • M.I. Voltmeter 0-300V - 1 No. • M I Ammeter 0-1A - 1 No. • Rheostat 100Ω/5W - 1 No. 	<p>Equipment/Machines</p> <ul style="list-style-type: none"> • Variable D.C. power supply 0-50V - 1 No. • Standard resistors for multipliers (Decade resistance box in 5 decades 1, 10, 100, 1000, 10000) OR - 3 Nos. • Variable tubular wire wound resistors • Battery 12V 100 A H - 1 No. • Variac 0-300V/5A - 1 No. <p>Materials</p> <ul style="list-style-type: none"> • Potentiometer 10k 2W - 1 No. • Resistor 1K 2W - 1 No. • Resin core solder - as reqd. • Connecting leads - as reqd. • Copper wire 18 SWG - as reqd. • Nichrome wire 18 SWG - 1/2 m

PROCEDURE

TASK 1 : Extension MC 0-15V voltmeter range to MC 0-30V voltmeter

- 1 Remove the cover of the MC 0-15V Voltmeter, examine and disconnect the series resistance, if any.
- 2 Connect the moving coil ends to the meter terminals and close the cover.
- 3 Form the circuit as shown in Fig 1.
- 4 Close the switch; gradually increase the DC voltage until full scale deflection is achieved in M_1 (voltmeter under test).
- 5 Record the reading of M_2 and then the voltage drop across M_1 at full scale deflection in Table 1.
- 6 Open the switch and disconnect the circuit.
- 7 Calculate the M C resistance of M_1 using Ohm's Law and record in Table 1.

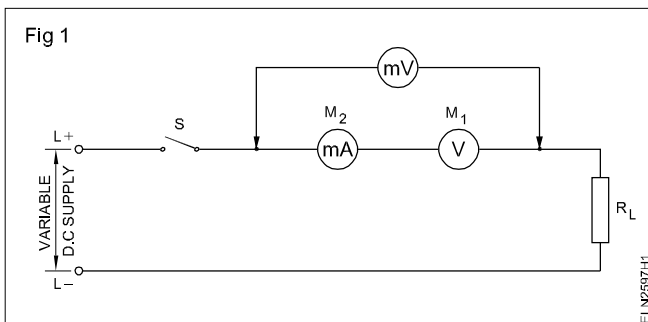

Keep the switch open and the variable DC supply at minimum level.

Table 1

Reading of M_2 at f.s.d. of M_1	Voltage drops across M_1 at f.s.d.	Resistance of MC of M_1
1	2	3

- 8 Calculate the resistance of the multiplier for the proposed range (say 0-30V) using the formula

Multiplier resistance =

$$\frac{\text{Proposed range of voltage-Voltage drop across MC at FSD}}{\text{MC current at FSD}}$$

9 Calculate the multiplying factor (M.F.) by the formula

$$MF = \frac{\text{Proposed voltmeter range}}{\text{Voltage drop across MC at FSD}}$$

10 Select the standard resistance suitable for the value of the multiplier resistance calculated in step 8 and connect them all in series with meter M_1 .

11 Form the circuit as shown in Fig 2, keeping the switch open.

Keep the variable D C Supply at minimum level.

12 Close the switch and increase the voltage gradually to get exact divisions in standard voltmeter M_3 .

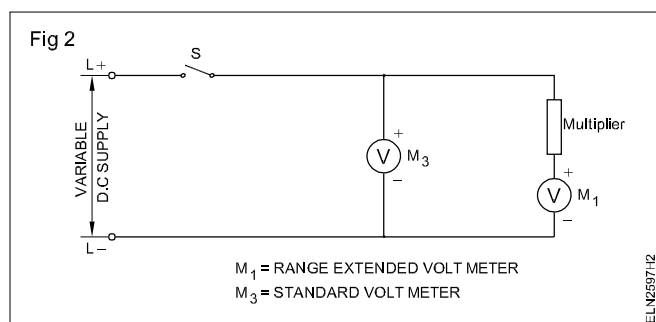

13 Record the readings of M_1 and M_3 in Table 2 for each setting (in M_3) until M_1 reaches the full scale deflection.

14 Open the switch and disconnect the circuit.

15 Calculate the actual voltage using 'M₁ reading' and the 'Multiplying factor' of the multiplier connected.

16 Calculate the error using the formula given below and record in Table 2.

$$\text{Error} = \text{standard meter} - \text{calculated voltage from the reading of } M_1$$

In case of non-availability of wire-wound resistors of different values of suitable wattage to form the multiplier resistance, you may make use of wire-wound tubular variable resistance for laboratory use and verify the working of the instrument in the extended range.

Set the value of variable wire-wound resistance exactly equal to the multiplier resistance using the Wheatstone bridge.

Table 2

SI No	Reading of M ₃	Reading of M ₁	Multiplying factor M.F.	Voltage = M ₁ x MF	Error (Col.2)-(Col.5)
1	2	3	4	5	6

TASK 2 : Extension of M.C 500 milliammeter range to 2.5 amperes

1 Connect the 0-500mA range milliammeter as shown in Fig 3 to the variable DC power supply. If a variable DC power supply is not available, make connections to a battery as shown in the circuit Fig 4.

2 Set the output voltage to the circuit at the minimum and close the switch S.

3 Gradually increase the voltage until the milliammeter reads full scale deflection.

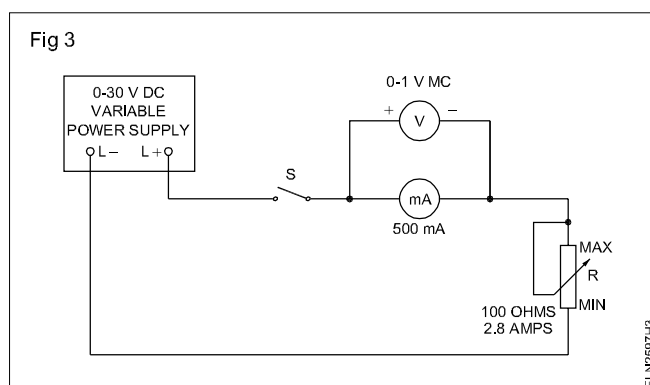

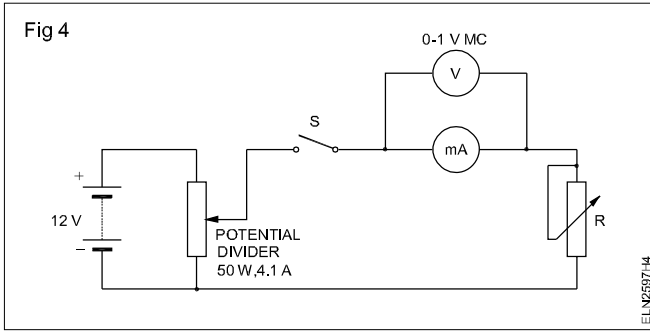

- 4 Observe and record the reading of the voltmeter and ammeter in Table 3. The measuring element indicates full scale deflection at $V_i = \text{--- V}$
 $I_i = \text{--- A}$.

Table - 3

Voltmeter reading in Volts	Ammeter reading in Amps.

- 5 Open the switch S and disconnect the circuit elements.
 6 Calculate the shunt resistance R_{sh} .

$$R_{sh} = \frac{V_i}{I_{sh}}$$

The voltage across the shunt resistance is then equal to V_i . The current I_{sh} in the shunt resistance is the difference between the end value of the measuring range $I = 2.5A$ and the current in the measuring element I_i , ie. $I_{sh} = I - I_i$.

- 7 Measure the exact length of the Manganin wire that has a resistance equal to R_{sh} as shown in Fig 5, using an ohmmeter and go to step 9. If a Wheatstone bridge is used, go to step 8.

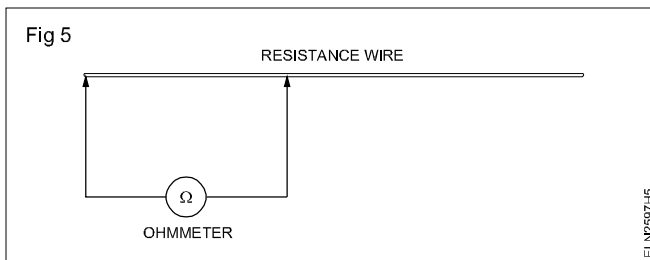

- 8 Set the ratio arm and variable resistance to the value which causes balance of the bridge when the unknown resistance value equals R_{sh} . Connect one lead from the instrument to the end of the wire, and with the other lead touch and move to cause null deflection. The point at which null deflection occurs indicates the length of wire.
 9 Cut the wire 1 cm greater in length than measured.
 10 Coil the wire with eye formation at both ends. Exercise care to see the excess length of 1 cm is used for eye formation at the ends. (Fig 6)

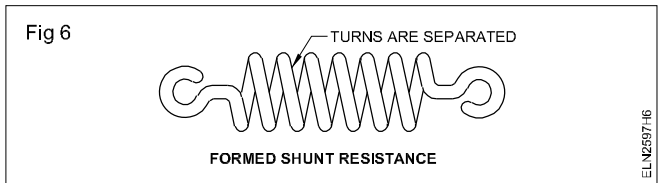

- 11 Connect the coiled wire as shunt across the terminals of the milliammeter.
 12 Set up the circuit according to the circuit diagram. (Fig 7)

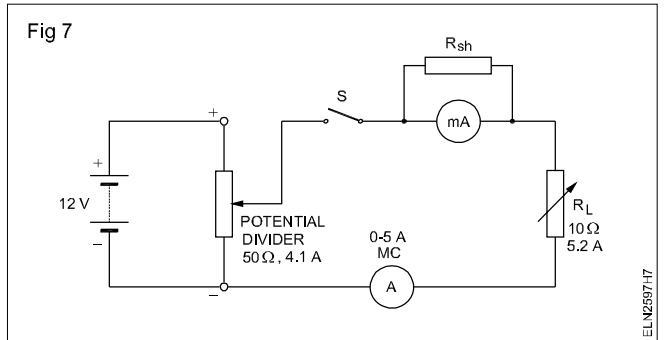

- 13 Adjust the variable load resistance R_L to 4 ohms.
 14 Switch on the power and adjust the output voltage to circuit, equal to 10V. Observe the ammeter deflection.
 15 Read the value of current 'I'.
 16 Verify that the readings shown are in amperes by inserting a 5A ammeter in series.

TASK 3 : Extension of 500 milliamperes ammeter range to 5 amperes

- 1 Calculate the shunt resistance R_{sh} following the instruction in step 6 of Task 2.
 2 Repeat the step 7 and 15 of Task 2.

TASK 4 : Extension of 100 milliampere ammeter range to 1 ampere

- 1 Following the steps 1 to 15 under Task 2 for 100 milliampere ammeter to extend its range to 1 ampere.
- 2 Consider the 100 milliampere ammeter with its range extended to 1.0A by external shunt as a single instrument.

TASK 5 : Calibrate a 0-50V MC type voltmeter

- 1 Check and set the pointer of the meter under calibration to read zero (mechanical zero setting).
- 2 Connect the 0-50V meter to be calibrated and a standard digital voltmeter across a regulated DC power supply as shown in the Fig 8.
- 3 With the output of the adjustable DC PSU set to zero Volt, get the connections checked by your instructor.
- 4 Increase the output voltage of the DC PSU such that the standard meter (V_2) reads 5V (1/10th of the range of the meter under calibration.).
- 5 Record the corresponding voltage reading of the meter under calibration (V_1) in Table 4
- 6 From the readings of the standard meter and the reading shown by the meter under calibration, find the % of error in the meter under calibration as given in Table 4
- 7 Repeat steps 4,5 and 6 to find the % error at different readings of the meter under calibration as given in Table 4
- 8 From the % error found at different readings, calculate and record the average % error of the meter under calibration.
- 9 Get your work checked by the instructor.

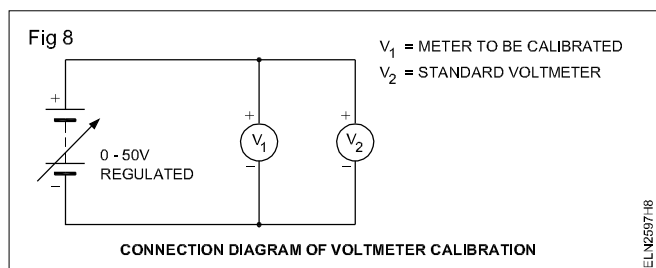

Table 4

Type of meter :

Range :

Sl. No.	PSU output volts	Voltmeter readings in volts		error ($V_2 - V_1$)	% of error
		Standard V_2	undercalibration V		
1	5	5			
2	10	10			
3	15	15			
4	20	20			
5	25	25			
6	30	30			
7	35	35			
8	40	40			
9	45	45			
10	50	50			

$$\text{Average \% error} = \frac{\text{Total \% error}}{\text{No. of reading}}$$

TASK 6 : Calibrate a 0 - 300V MI voltmeter

- 1 Check and set the pointer of the meter under calibration to read zero(mechanical zero setting).
- 2 Connect the given 0-300V MI AC meter to be calibrated and a standard digital AC voltmeter across the variac (0-300) output using rheostat as shown in that Fig 9.

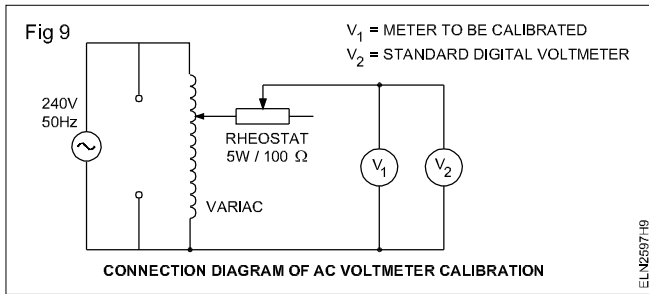

Use well insulated wires for interconnection. Insulate all open contacts and terminals before connecting the circuit to mains. Do not connect the variac to mains supply terminals till the wiring is completed and checked by your instructor. Insulate yourself while handling and taking readings.

3 With the output of the variac set to zero Volt, connect the Variac to 240V, 50Hz mains supply (with mains switched-off). Get the connections made checked by your instructor.

- 4 Power-on mains supply to variac. Increase the output of the variac such that the standard meter (V_2) reads 30V (1/10th of the range of the meter under calibration).
- 5 Record the corresponding voltage reading of the meter under calibration (V_1) in Table 5
- 6 From the readings of the standard meter and the reading shown by the meter under calibration, find the % of error in the meter under calibration using formula given in Table 5.
- 7 Repeat steps 4,5 and 6 to find the % error at different readings of the meter under calibration as given in Table 5.
- 8 From the % error found at different readings, calculate and record the average % error of the meter under calibration using formula given in Table 5.
- 9 Get your work checked by the instructor.
- 10 Paste a slip on the calibrated meter indicating date of calibration and average % error.

Table 5

Type of meter :

Range :

Sl. No.	PSU output volts	Voltmeter readings in volts		error ($V_2 - V_1$)	% of error $\frac{V_2 - V_1}{V_2} \times 100$
		Standard V_2	undercalibration V_1		
1	30	30			
2	100V	100			
3	150V	150			
4	250V	200			
5	250V	250			
6	300V	300			

$$\text{Average \% error} = \frac{\text{Total \% error}}{\text{No. of reading}}$$

TASK 7 : Calibrate a 0-500mA MC type ammeter

- 1 Check and set the pointer of the meter under calibration to read zero (mechanical zero setting).
- 2 Connect the given 0-500mA DC meter to be calibrated and a standard digital DC Ammeter for some range across the output of a regulated DC power supply via a rheostat as shown in the Fig 10
- 3 Set the Rheostat to its half resistance position and set the output of DC PSU to zero volts. Get the wired circuit checked by your instructor.
- 4 Increase the output of the PSU slowly till the standard ammeter (A_2) read 500 mA (full scale value of the ammeter under calibration (A_1)).

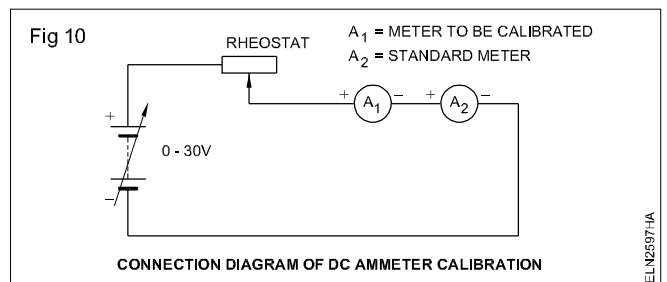

- 5 Adjust the rheostat such that the standard ammeter (A_2) reads 450mA (decrease in current equivalent to 1/10 of the full range of the meter under calibration).

- 6 Record the corresponding reading on the ammeter (A1) under calibration in Table 6.
- 7 From the readings of the standard meter and the reading shown by the meter under calibration, find the % of error in the meter under calibration using the formula given in Table 6.
- 8 Repeat step 5,6 and 7 for the values given in Table 3 to cover the complete range of the ammeter under calibration.
- 9 From the % error found at different readings, calculate and record the average % error of the meter under calibration.
- 10 Get your work checked by the instructor.
- 11 Paste a slip on the calibrated meter indicating date of calibration and average % error.

Table 6

SI.No	Ammeter reading in mA		Error ($I_2 - I_1$)	% of error $\frac{(I_2 - I_1)}{I_2} \times 100$
	Standard I_2	Undercalibration I_1		
1	50			
2	150			
3	250			
4	350			
5	450			
6	500			

$$\text{Average \% error} = \frac{\text{Total \% error}}{\text{No. of reading}}$$

TASK 8 : Calibrate a 0 - 1A MI type ammeter

- 1 Check and set the pointer of the meter under calibration to read zero (mechanical zero setting).
- 2 Construct a circuit as in Fig 11. Note that the circuit at Fig 10 similar to that of Fig 11 except for the variable DC Power Supply is replaced by a variac to provide suitable AC current. Get the wired circuit checked by your instructor.

Use well insulated wires for interconnection. Insulate all open contacts and terminals before connecting the circuit to mains. Do not connect the variac to mains supply terminals till the wiring is completed and checked by your instructor. Insulate yourself while handling and taking readings.

- 3 The procedure for calibrating the given MI ammeter by comparison method is similar to that practiced in the

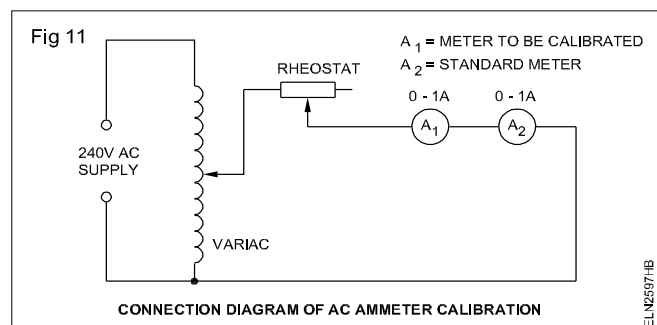

previous task 7 for calibrating a MC ammeter except that the source is mains supply and the current levels are different. Record your observation in Table 7.

- 4 Get your work checked by the instructor.

Table 7

SI. No.	Average reading Standard I_2 (mA)	error under calibration I_1	% error $\frac{(I_2 - I_1)}{I_2} \times 100$
1	900		
2	800		
3	500		
4	300		
5	100		

$$\text{Average \% error} = \frac{\text{Total \% error}}{\text{No. of reading}}$$

Determine errors in resistance measurement by voltage drop method

Objectives: At the end of this exercise you shall be able to

- determine errors in resistance measurement by voltage drop method
- connect suitably the voltmeter and ammeter to minimize measurement errors.

Requirement	
<p>Tools/Instruments</p> <ul style="list-style-type: none"> • Insulated cutting pliers 150 mm - 1 No. • Screwdriver 150 mm - 1 No. • Connector screwdriver 100 mm - 1 No. • 0-30V mC panel type voltmeter - 1 No. • Multimeter - 1 No. • 0-5 amps ammeter, P.M.M.C type - 1 No. • Ohmmeter, Shunt type 0-100 ohms - 1 No. <p>Equipment / Machines</p> <ul style="list-style-type: none"> • 24V DC power supply unit - 1 No. • Rheostat 10 ohms, 20 ohms and 50 ohms 4A capacity each - 1 No. 	<p>Materials</p> <ul style="list-style-type: none"> • DPST knife switch 16 A - 1 No. • SPDT knife switch 16A - 1 No. • 5A fuse wire - 1 No. • P.V.C. cable 48/0.2mm - 10 m • Glass cartridge fuse with holder 100 mA - as reqd.

PROCEDURE

1 Form the circuit as shown in Fig 1. (Use only high sensitivity voltmeter.)

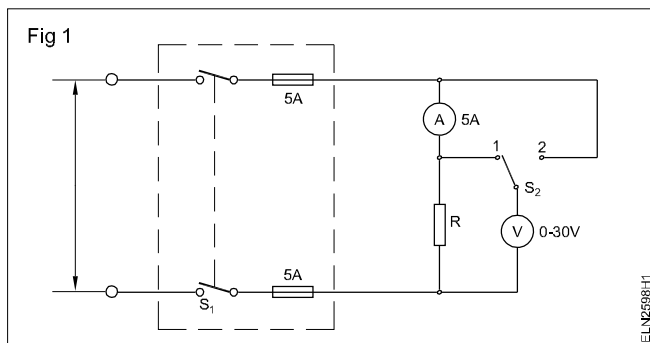

2 Measure the value of resistor R and enter the measured value in Table1.

3 Switch on the supply keeping switch S₂ at position1, across the resistor only. Read the voltmeter and ammeter and record the readings in Table 1 switch off the circuit.

4 Calculate the resistance value from the measured quantities using the formula $R = V/I$, and enter the values in Table 1.

5 Change switch S₂ to position 2, across the resistor and ammeter. Read and record the voltage and the current.

6 Repeat step 4 for these values.

7 Calculate and enter the error occurred in the measurement of resistance by using the formula

$$\% \text{ error} = \frac{(R_{2cal} - R_{2mes}) \times 100}{R_{2mes}}$$

8 Repeat the same procedure for different values of R as given in Table 1.

Table 1

Resistance value			Voltmeter connected across	Voltage	Current	Calculated value of resistance $R = V/I$	% error = $\frac{(R_{2cal} - R_{2mes}) \times 100}{R_{2mes}}$
SI No.	Marked R_{Mar}	Measured R_{Mes} ohms					
1	10		R only				
			R & A				
2	20		R only				
			R & A				
3	50		R only				
			R & A				

Test single phase energy meter for its errors

Objectives : At the end of this exercise you shall be able to

- identify the creeping in energy meter
- test the energy meter for starting current error
- select suitable loading arrangements for determining errors in energy meters
- determine the percentage error in an energy meter.

Requirements	
<p>Tools/Instruments</p> <ul style="list-style-type: none"> • Electrician's Tool Kit - 1 No. • Single phase energy meter 5A 250 V 50HZ - 1 No. • Voltmeter MI 0 - 300V - 1 No. • Ammeter MI 0 - 5 A - 1 No. • Power factor meter 240 V 5 A 50 Hz - 1 No. • Ammeter MI 0 - 50mA - 1 No. 	<p>Equipment/Machines</p> <ul style="list-style-type: none"> • Single phase capacitor motor with brake load 240V 50 Hz AC 1/2 kW - 1 No. • Lamp load single phase 250 V 50 Hz 1.25 kW - 1 No. • Auto-transformer 0 to 270V 8A 50 Hz - 1 No. <p>Materials</p> <ul style="list-style-type: none"> • Electric bulb 5 W 240 V with holder - 1 No. • PVC insulated cable 1.5 sq. mm 250 V grade - 10 m

PROCEDURE

Adjustment of errors inside the energy meter is beyond the scope of this course as it requires costly equipment like rotating sub-standard meter etc. Hence the simplified method of finding errors only is included here.

TASK 1 : Check the energy meter at no load (to find the creeping error)

- 1 Connect the energy meter through an auto-transformer as shown in Fig 1.
- 2 Vary the input voltage to the energy meter between 80% and 110% of the rated voltage of the energy meter.

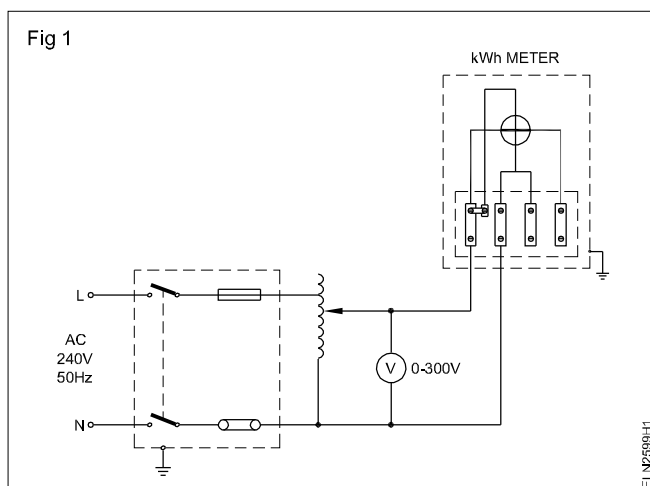

For an energy meter rating of 240 Volts the input voltage is between 192 V to 264 V. Observe, if the meter disc is rotating or not. The load should not be connected or the load switch should be 'off' during the observation period.

- 3 Write your observations correlating your findings from the above experiments with the recommendation given in IS 722.

OBSERVATION

As per IS 722 (Part I) 1977 the meter shall not make a complete revolution at any voltage between 80% and 110% of the reference voltage.

TASK 2: Task for starting current error in energy meter

- 1 Connect low load (5 W lamp) as shown in Fig 2.
- 2 Switch on the load and observe the meter rotation.
- 3 Write your observations, correlating your finding from the above experiment with the recommendation given in IS 722 (Part III).

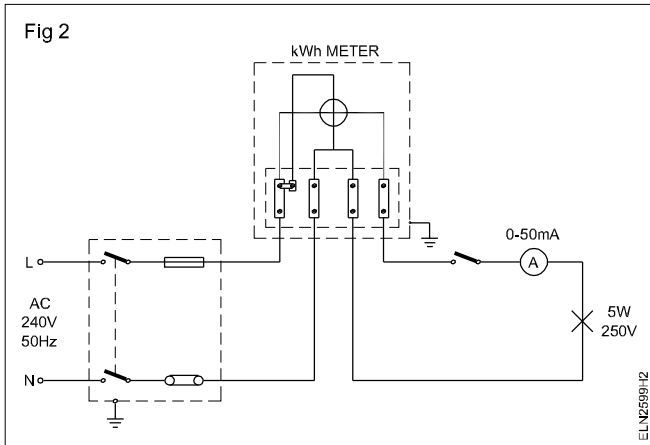

OBSERVATION

As per IS 722 (Part II) 1977 the starting current shall be 0.5% of the rated basic current across = 1 for dial and pointer type register whereas for drum type register it will be 0.75%. For meters provided with reverse stop the values will be 1% and 1.5% respectively.

TASK 3 : Task for percentage error in single phase energy meter

- 1 Make the connections as shown in Fig 3 with the lamp load.

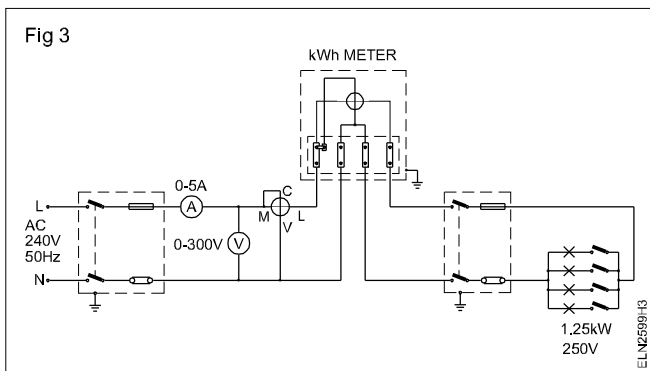

- 2 Switch 'ON' the lamps so that 25% of the rated current of energy meter flows in the circuit.
- 3 Tabulate the voltmeter, ammeter and P.F. meter readings in Table 1.
- 4 Keeping the load constant, count the number of revolutions of the energy meter disc for 2 minutes (120 seconds) and record the same in Table 1.

- 5 Calculate the true energy by using the formula

$$\text{True energy} = \frac{E \times I \times \cos \phi \times t}{1000 \times 3600} \text{ kWh}$$

where 't' is the time in seconds.

- 6 Calculate the energy registered (recorded) by the meter using the formula

$$\text{Recorded energy} = \frac{\text{No. of revolutions}}{\text{Meter constant}} \text{ kWh} = \frac{N}{K} = \text{kWh}$$

- 7 Find the error using the formula

$$\text{Error} = \text{Recorded energy} - \text{True energy.}$$

- 8 Calculate the percentage error, using the formula

$$\text{Percentage error} = \frac{R - A}{A} \times 100$$

where R = Energy registered by the meter

A = True energy.

Table 1

SI. No.	Load reading	Voltmeter reading	Ammeter reading	P.F. meter reading	Time in Sec	True energy	Revolution counted N	Meter constant K	Recorded energy	% error
1	Resistive									
2	25%									
3	50%									
4	75%									
4	100%									
	Inductive									
1	25%									
2	50%									
3	75%									
4	100%									

Repeat the working steps from 2 to 8 for 50%, 75%, 100% resistive and inductive loads and enter in Table 1.

For inductive load, make the connection as shown in Fig 4.

For checking the proper registraion of energy, verify the readings through initial and final reading differences recorded in the energy meter. As per I.S. 722 (Part III) 1977, the percentage error shall not exceed $\pm 2\%$, both at unity power factor and at 0.5 lagging.

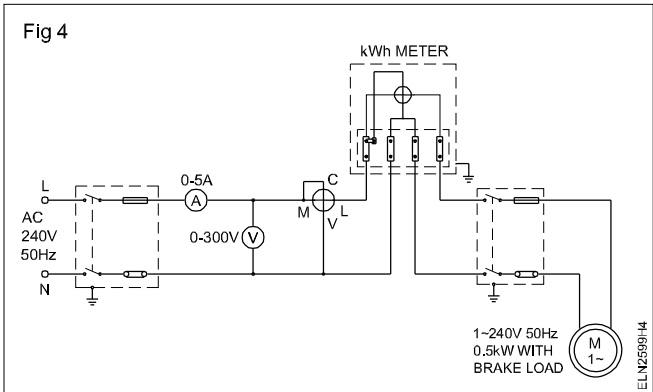

If the above errors are beyond the limitation prescribed in I.S., take action for calibration of the energy meter at the meter testing department attached to the electricity board.

TASK 4 : Plot the error graph

- From the tabulated readings, plot the graph of percentage load versus percentage error separately for unity PF and for lagging PF in Fig 5.
- Show the error graph to your instructor and discuss with him regarding meter calibration.

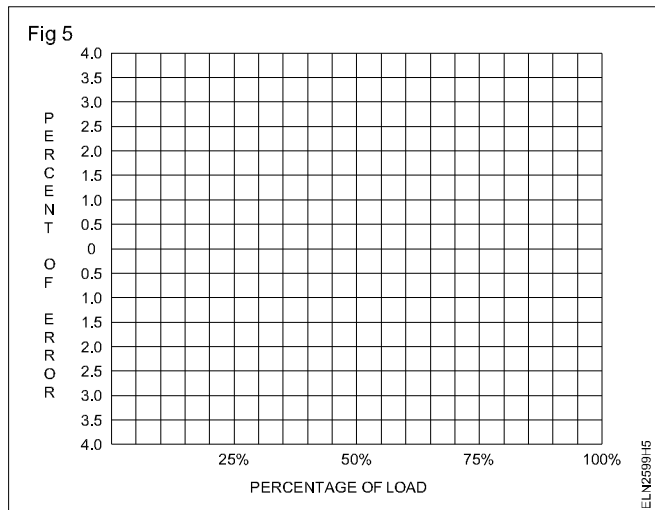

Dismantle and assemble Power parts of various Power appliance e.g cooking range, geyser, washing machine and pump set

Objectives: At the end of this exercise you shall be able to

- dismantle the cooking range, geyser, washing machine and pump set
- assemble the dismantled electrical appliances
- test them for their working
- replace the faulty parts with good ones where ever necessary.

Requirements	
Tools/Instruments	
• Electrician Tool Kit	- 1 Set
• Spanner set 6 to 22 mm (6 Nos)	- 1 Set
• Megger 500 V	- 1 No.
• Multimeter	- 1 No.
• Test lamp 60 w / 240 V	- 1 No.
• Pulley puller 3 leg 150 mm	- 1 No.
Equipment / Machines	
• Cooking range 1500 W / 240 V	- 1 No.
• Geyser 1500W/240 V - 15 liters	- 1 No.
• Washing machine ordinary or semi automatic types 240 V / 50 Hz	- 1 No.
• Pump set coupled with single phase motor 240V /50Hz	- 1 No.
Materials	
• Service manual	- 1 No.
• Cleaning brush - 2.5 cm dia	- 1 No.
• Cotton waste	- as reqd.
• Kerosine	- as reqd.
• Grease	- 200 gms

PROCEDURE

TASK 1 : Dismantle and assemble the cooking range

- 1 Note the name plate details of the electric cooking range in Table 1.
- 2 Disconnect the power supply from the cooking range
- 3 Open the terminal connection box (Refer Fig 1)

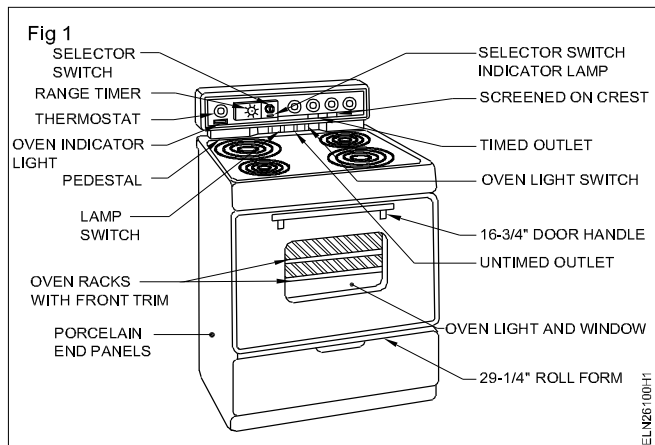

- 4 Check the proper tightness of the screw at selector switch, indicator lamp, range timer and thermostat.
- 5 Remove the cooking range and check the continuity of the surface heating unit element one by one.
- 6 Check the correct shape, wattage and voltage of the element (Refer Fig 2)
- 7 Open the porcelain end panel which is at bottom of the cooking range.

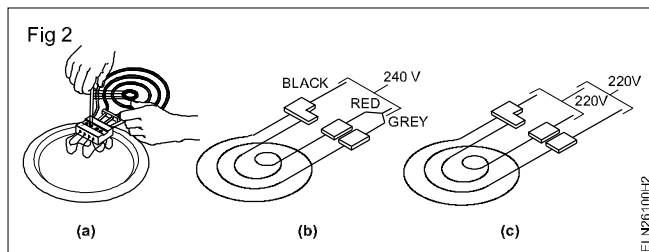

- 8 Check the condition of the oven racks (Fig 1)
- 9 Measure the insulation value between the all terminals to body of the cooking range.
- 10 Assemble and connect the electric cooking range to the supply (Fig 3)

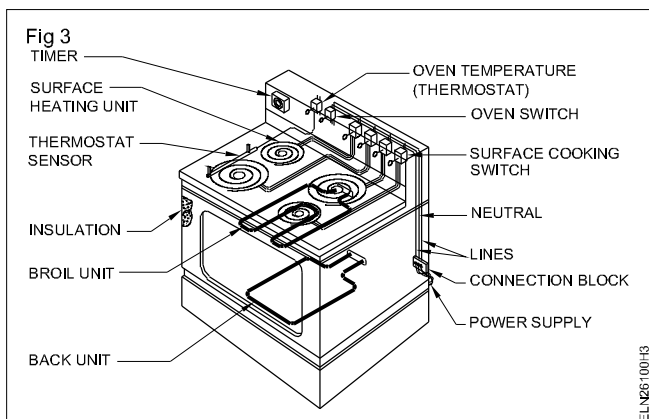

TASK 2 : Dismantle and assemble the geyser

- 1 Note down the name plate details of the geyser in a separate Table similar to table 1
- 2 Disconnect the power supply from the geyser
- 3 Open the inspection cover for Power terminals connection and thermostat installation. (Refer Fig 4)
- 4 Check proper tightness of the screw at thermostat, pilot lamp, and heating element
- 5 Conduct visual examination of the power cord pin terminals and termination of appliance.
- 6 Conduct insulation test between the leads, lead and earth and record in a separate Table
- 7 Measure the insulation resistance between element and body and record in a separate Table
- 8 Assemble and connect the geyser to the supply.

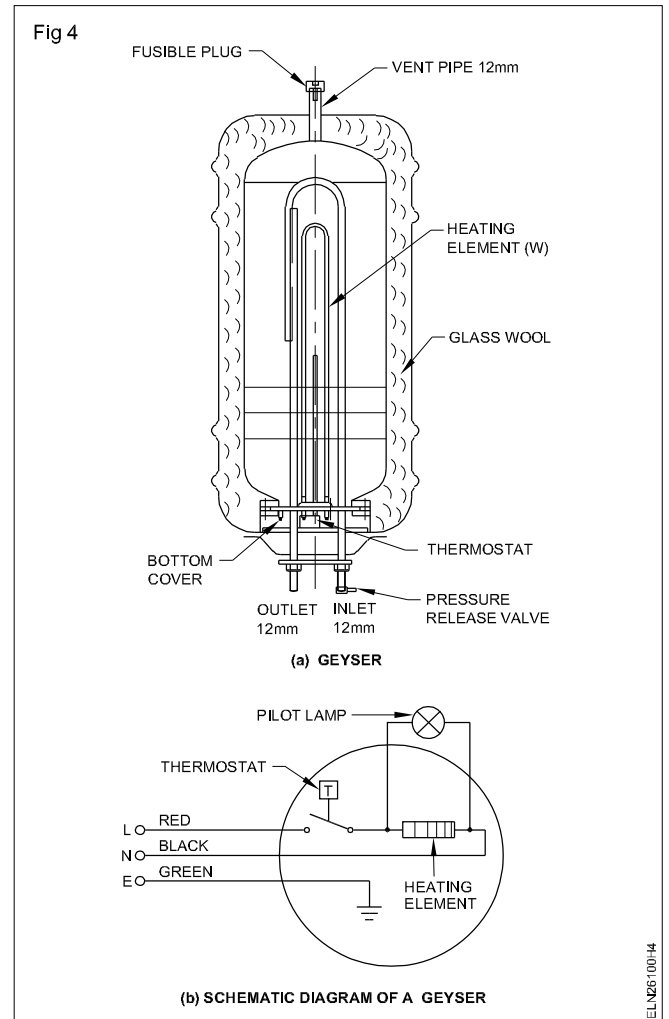

TASK 3 : Dismantle and assemble washing machine

- 1 Note the name plate details of the washing machine in a separate Table (Fig 5)

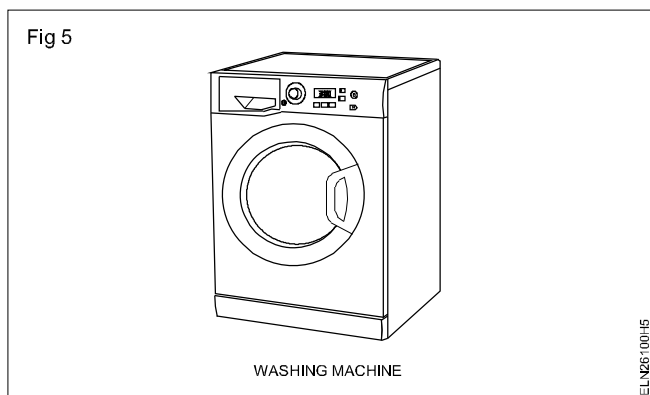

- 2 Disconnect the power supply from the washing machine.

- 3 Open the terminal connection panel and check the proper tightness of the screws
- 4 Remove the washing drum from the washing machine.
- 5 Check the inlet pipe and out let pipe
- 6 Check the outgoing valve
- 7 Check the tightness of shaft pulley / drum belt
- 8 Check the rubber bushings that are used in the machine for absorbing mechanical vibration
- 9 Conduct insulation test to the motor by using a megger.
- 10 If every thing is ok, place the drum and close the inspection hatch/cover.
- 11 Connect the machine to the supply for its working

TASK 4 : Dismantle and assemble pumpset

- 1 Note the name plate details of the pumpset in separate Table.
- 2 Disconnect the supply from the pumpset
- 3 Dismantle the pumpset (Fig 6)
- 4 Check the shaft for smooth running, carbon seal, motor adaptor, Drive collar, impeller, casing gasket, bearings (refer Fig 6)
- 5 If every thing is satisfactory, assemble the pumpset
- 6 Connect the pumpset to the supply for its working . (Fig 7)

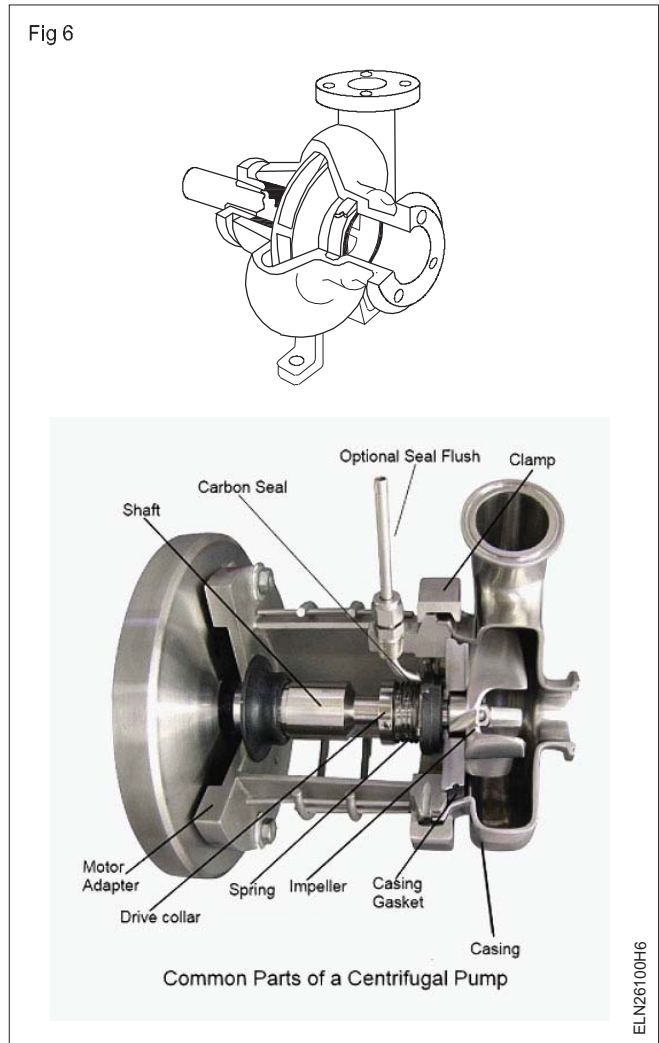
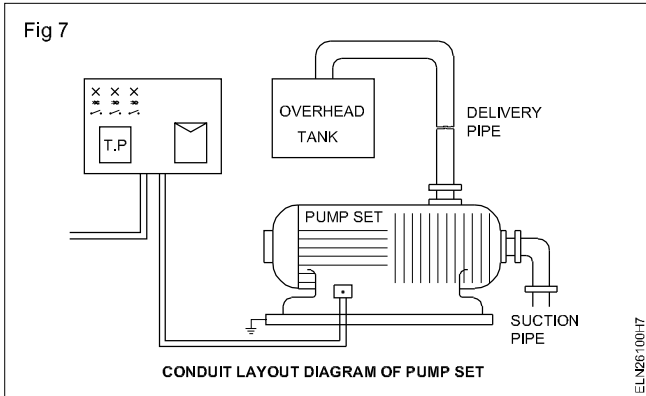

Table 1

Name of the appliance :		Serial No :	
Voltage :		Current :	
Supply :		Wattage :	
Capacity :		Make :	
Cord Insulation	Between line	Between line/body	Date of servicing
 Megohm Megohm	
Element insulation	Between terminal and body / thermostat		Recommended Repair Replacement if any
	Cold		
	Hot		

Service and repair of bell / buzzer

Objectives: At the end of this exercise you shall be able to

- test, identify the fault and repair the calling bell
- test identify the fault and repair the buzzer.

Requirements	
<p>Tools / Instruments</p> <ul style="list-style-type: none"> • Trainee's kit - 1 No. • Wire stripper 150 mm - 1 No. • D.B. Electrician Knife 100mm - 1 No. • Mini Screwdriver set - 1 Set • Insulated nose plier 150mm - 1 No. • Multimeter - 1 No. • Megger 500V - 1 No. • Nylon mallet 125 gm - 1 No. 	<p>Equipment / Machines</p> <ul style="list-style-type: none"> • Power bell-12V/24V - 1 No. • Buzzer-12V/24V - 1 No. <p>Materials</p> <ul style="list-style-type: none"> • Connecting wires - as reqd. • Insulation tape 20mm P.V.C - 1 Roll • Spare components - as reqd.

PROCEDURE

TASK 1 : Test, identify the fault and rectify the Power bell

If the bell is not working it means the fault may be in any part of bell circuit from push button to the bell.

Assume, the fault is in push button, bell assembly circuit wiring

i Fault in push button

- 1 Remove the fixing screw and pull out the push button
- 2 Disconnect the wires by loosening the terminal.
- 3 Bring the two bare wire ends together.

if bell rings, the fault is in push button. Remove the buttons and replace it.

- 4 Install new push button, by connecting the two wires to terminal screws of new push button.
- 5 Test it for its good working condition and fix the push button

ii Fault in bell / assembly

- 1 Connect and test the bell for its working.

If bell does not ring, the fault may be in bell assembly wiring. We assume the fault is in bell.

- 2 Remove snap-on cover of bell by lifting the cover slightly upward then pull out and remove the cover.

Look for the number of wires, 2 or 3 or more which depends on number of tones in ring bell. But standard bell or buzzer has two wires only.

- 3 Disconnect the wires by loosening terminal screws.

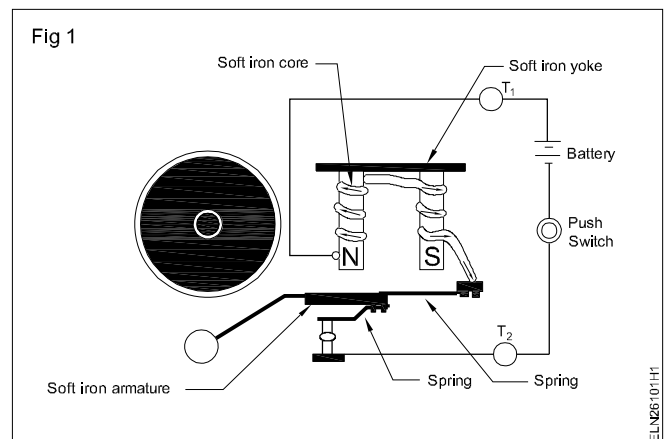

- 4 Connect them to 12V.

If bell sounds (or) bulb gives light when the bell button is pushed, it means, the bell is in good working condition.

- 5 Replace and install a new and test it.

Important parts of an electric bell are :

- 1 Electromagnet
- 2 Armature
- 3 Spring
- 4 Armature rod
- 5 Hammer
- 6 Gong

TASK 2 : Test, identify the faults and repair the buzzer

- 1 Connect the components of buzzer as in Fig.2
- 2 Press the key switch.

It gives off a loud noise (buzz) - if it does not make noise/ sound it means, fault may be in circuit or battery or solenoid coil.

If fault in cell/battery

- 3 Check the circuit by testing with other cell, if it gives peep sound replace with new cell of same range and test it.

If fault is in solenoid

- 4 Connect the buzzer with new cell and switch 'ON' the circuit.

If it does not give sound it indicates, the fault is with switch (or) connections.

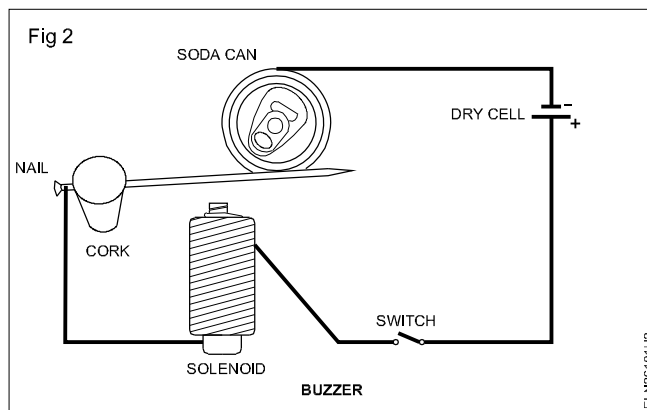

- 5 Trace the circuit for loose connection, and rectify it.

If the switch contacts are found carbonized, clean it (or) replace it.

Service and repair of electric iron, electric kettle, cooking range and geyser

Objectives: At the end of this exercise you shall be able to

- connect and test the given automatic iron for its working
- dismantle the automatic iron and reassemble it
- trace and identify (or) locate the faults in an automatic iron
- replace the faulty parts with good one
- test the electric kettle element and identify the defect
- replace the old element with a new one
- assemble the kettle and test for its working
- dismantle the suspected parts of the cooking range
- test the continuity of heating element
- replace the burn out heating element and worn out selector switch
- reassemble, connect and test the cooking range
- test the line cord for continuity
- dismantle a geyser
- trace identify and locate faults in a geyser
- replace faulty parts with good ones
- assemble the geyser and test for its working.

Requirements			
Tools/Instruments		Materials	
• Screwdriver 150mm	- 1 No.	• Kettle Element 500W/250V	- 1 No.
• Spanner set 6 to 22mm (6 Nos)	- 1 Set	• Asbestos sheet and fibre washers	- as reqd.
• Megger 500 V	- 1 No.	• Test lamp 100W/240V	- 1 No.
• Multimeter	- 1 No.	• Element suitable for available	
• Electrician tool kit	- 1 Set	• Cooking range 1500W, 250V	- 1 No.
• Cutting plier 150mm	- 1 No.	• Geyser heating element 1500W, 240V	- 1 No.
• Tester 500 V	- 1 No.	• Geyser thermostat	- 1 No.
• Nose plier 150 mm	- 1 No.	• 3- core flexible cord	
		(48/0.2 with 15A, 3 pin plug)	- 1 No.
		• Insulating material such as asbestos	
		and mica sheets Suitable for electric	
		Iron	- as reqd.
Equipment/Machines			
• Automatic electric iron box			
750W 250 V	- 1 No.		
• kettle (sauce pan type) 500W/ 250V	- 1 No.		
• Electric cooking range 1500W/250 V	- 1 No.		
• Geyser 1500W 250V 25 liters	- 1 No.		
• Megger 500 V	- 1 No.		

TASK 1 : Service and repair of electric iron

- 1 Conduct a visual examination of the power cord and plug, after interpreting the name plate details
- 2 Conduct preliminary test for
 - short circuit, continuity & insulation
 - earth fault
 - defective element circuit
- 3 Replace the cord, if necessary
- 4 Check for the insulation resistance between line terminal of the iron and the body of the iron (Fig 1) and record in Table 1.

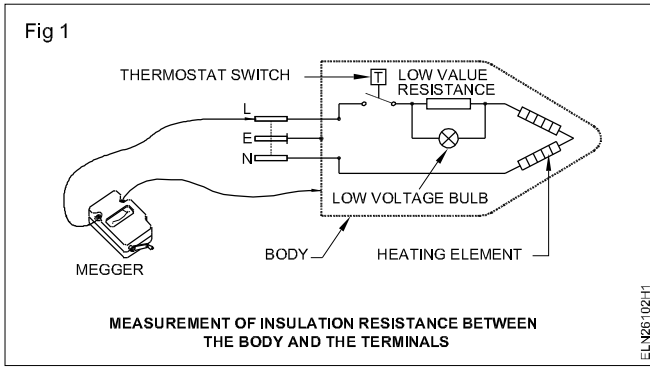

Table - 1

Terminals	Value in Megohms
L & Body	
N & Body	
E & Body	
Plug pin L & Body	
Plug pin N & Body	
Plug pin E & Body	

Disconnect the indicator bulb if any before the short, open and IR test.

Always disconnect the iron from supply while testing with insulation tester / Megger.

- 5 Check for insulation resistance between the neutral terminal and earth.
- 6 Connect the electric iron to the mains and check for its working
- 7 Check the presence of dangerous voltage existing between the body and earth of the supply with a neon tester or voltmeter.

In case of earth fault

- 8 Disconnect the electric iron from the supply, dismantle it. Visually inspect and test with a multi-meter/megger for any contact of live wire with the body
 - insulation failure
 - broken parts
 - damaged thermostat/actuating leaf porcelain
 - switch actuator.
 - Check for continuity of thermostat and heating element.

9 Rectify the fault by replacing the defective part (element, thermostat etc.) Fig 2 (A & B).

In case of open in element circuit

- 10 Remove the cover to check the thermostat, indicator bulb circuit and element
 - Connect the series test lamp to the element circuit shorting the contacts of the thermostat indicated

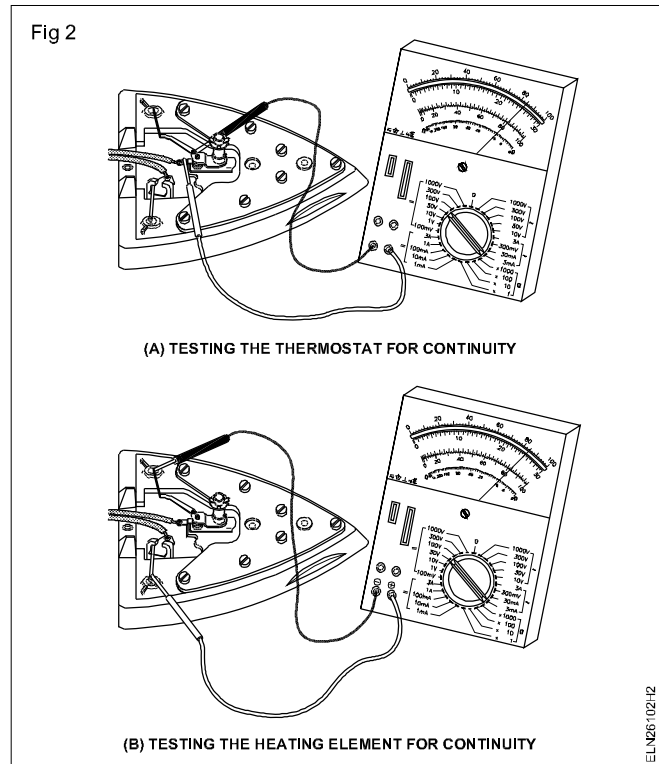

by 1 in Fig 3. If the test lamp glows the thermostat is defective.

- Connect the terminals of the indicating bulb by a piece of insulating wire, shown by 2 in Fig 3. If the test lamp glows the trouble is in this section.
- Short the terminals of the element shown by 3 in Fig 3. If the lamp glows the element is open. Replace the element.

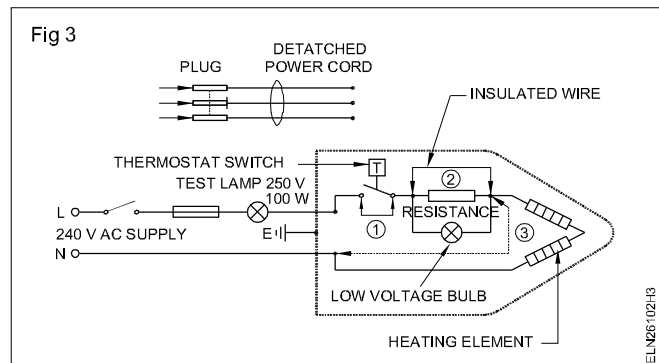

Failure of temperature setting controller

- 11 Check the adjusting knob for proper fixing and actuation of shaft. (Fig 4)
- 12 Open the contacts of the thermostat and inspect them visually.
- 13 Clean the pitted or burnt out contacts.
- 14 Check for the actuating mechanism. (Heat the thermostat by a suitable external heating device.)
- 15 Assemble the iron and test for good working.

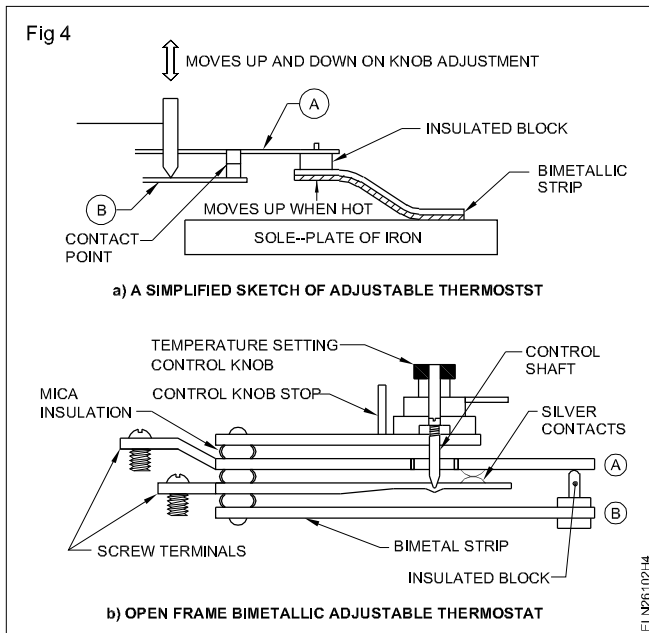

TASK 2 : Service and repair of a Kettle

1 Record the name-plate details of the appliance.

Name-plate Details

2 Disconnect the power cord and check the power cord for continuity of the cable, soundness of the terminal connection and insulation resistance between the line, neutral and earth terminals.

If found defective, either repair or replace the power cord.

3 Check the continuity of the kettle heating element either by using a test lamp or a Megger without opening the kettle.

If there is no continuity, the element is assumed to be open and it has to be replaced

4 Check the insulation resistance between the appliance socket terminals and the body of the kettle.

If the insulation resistance is less than one Megohm, the kettle element needs to be replaced.

5 Read the assembly diagram in the instruction book of the kettle and dismantle the parts in the sequence recommended by the manufacturer.

6 In the absence of the manufacturer's recommended sequence diagram of the assembly, the following parts may be removed observing the correct procedure as shown in the exploded Fig 5.

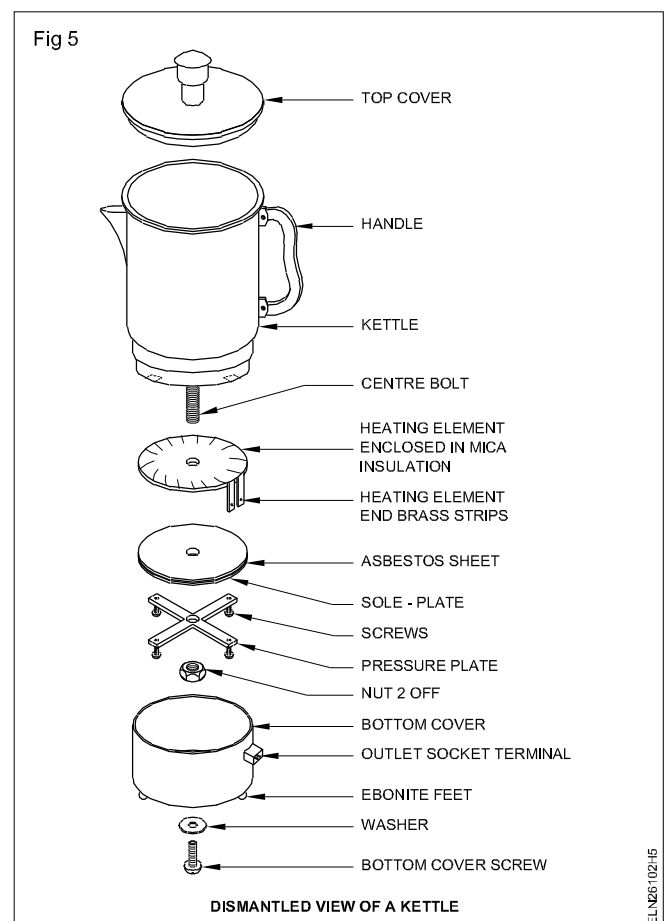

- Bottom cover
- Pressure plate
- Sole-plate with asbestos insulation
- Element

- Obtain a suitable element of the right shape, wattage and voltage and necessary mica and asbestos sheets of the same type and quality.
- Check the element for its continuity and ohmic value.
- Replace the new element in position.
- Assemble the parts in proper order and connect the appliance.

Take care to fit the asbestos sheet and the sole plate at the sole plate housing in the correct order.

- Measure the insulation resistance between the body of the appliance and its terminals before and after connecting the power cord.

Switch 'ON' the kettle only after filling water in it.

- Test the appliance with supply for its working.

TASK 3 : Service and repair of a cooking range

- Note the name plate details of the electric cooking range.
- Disconnect the power supply from the appliance.
- Study the connection diagram, given by the manufacturer or trace the connections of the cooking range (Fig 6).

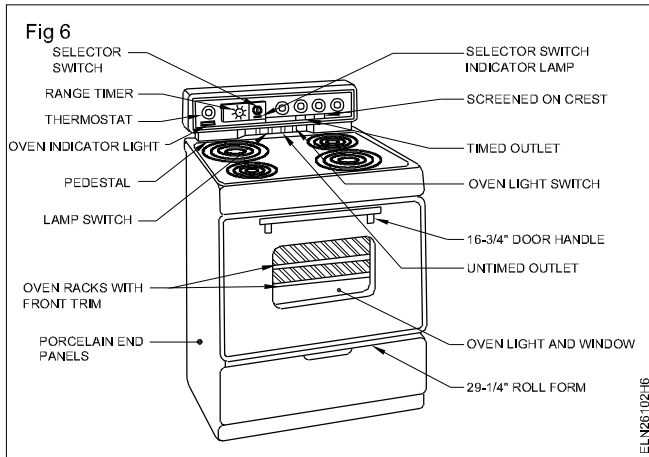

- Check the continuity of the surface unit element one by one.
- Replace the burnt out surface unit element as shown in Fig 7.

Before replace the coil check the correct shape, wattage and voltage of the element. Do not attempt to open parts which are not notified as defective.

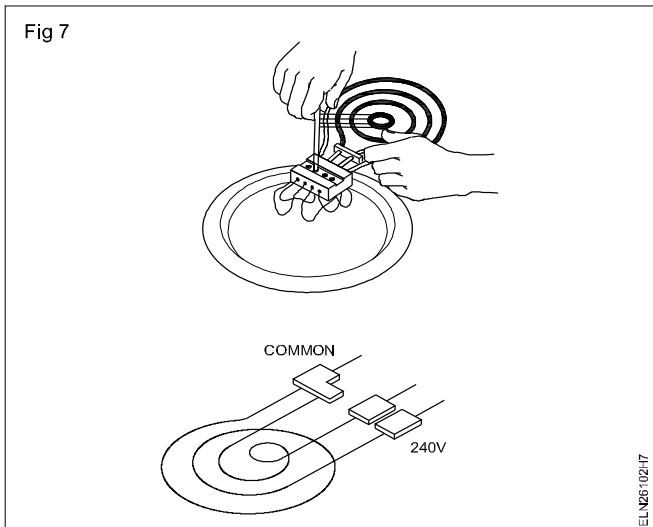

- Assemble and connect the electric cooking range.
- Measure the insulation value between the terminal to body of the appliance at various positions of all the switches.

Insulation resistance value should be more than one Megohm.

- Check the appliance with the supply for its working condition.

TASK 4 : Replace the wornout selector switch of cooking range

- Open the cover of the defective switch, trace the connections and note down the position and column of cables.
- Open the connections of the switch from the terminals.
- Check the continuity of input and output of the selector switch.

- Confirm the condition of the contacts. If found wornout, then remove the switch from the appliance. (as shown in Fig 8).

Take care to fix the screws, washers at the complete housing of the selector switch.

- Replace the new selector switch in position.

- 6 Connect the cables as per made in step 1.
- 7 Measure the insulation resistance between line terminals and the body of the cooking range at various positions of all the switches. Measured insulation resistance should be above one megohms.
- 8 Test the assembled switch with the supply for its working.

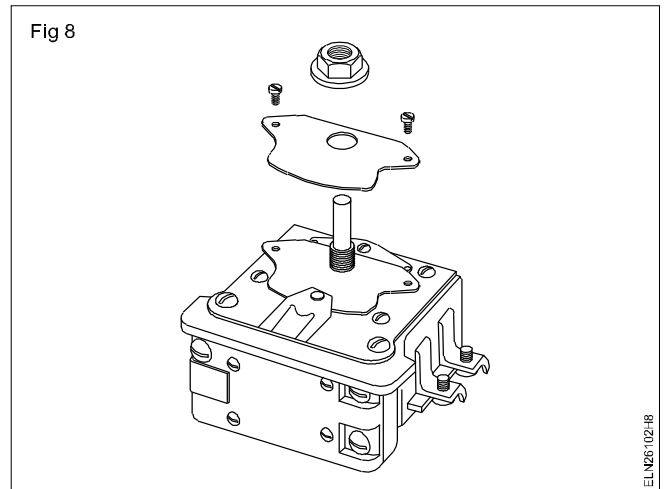

TASK 5 : Service and repair of a geyser

- 1 Record the details of the appliances in Table 2
- 2 Open the inspection cover for Power terminals connection and thermostat installation in the geyser after removing the power plug. (Fig 9)

Check and ensure that the switch is off before removing the power plug.

- 3 Connect a visual examination of the i) power cord ii) plug pin termination and iii) termination at appliance.
- 4 Check for proper tightness and good Power contact at terminations. Replace the plug pin if found pitted.
- 5 Conduct the insulation test on the cord - between the leads, lead and earth. Enter in Table 1
- 6 Measure the insulation resistance between the element and the earth/body and record in Table 1. The minimum value of the insulation resistance should be one megohm. If it is less than one megohm, send the geyser for repair and rectification.
- 7 Connect the geyser to the supply and switch on the appliance, keeping the inspection/bottom cover of the Power connections open.

The geyser should be switched on only with water in the container.

- 8 Observe that the heating process is cut off by the actuation of the thermostat. (The time depends on the capacity of the geyser and the thermostat setting).
- 9 Switch off the supply. Remove the plug. Measure the insulation resistance value between the terminals and the body of the heater/thermostat while it is hot and record the value in Table 1
- 10 Replace the thermostat if unit in the insulation value is less than one megohm.
- 11 Refit the inspection cover. If the insulation value is normal (i.e. above one megohm) apply grease over the screw before fitting.

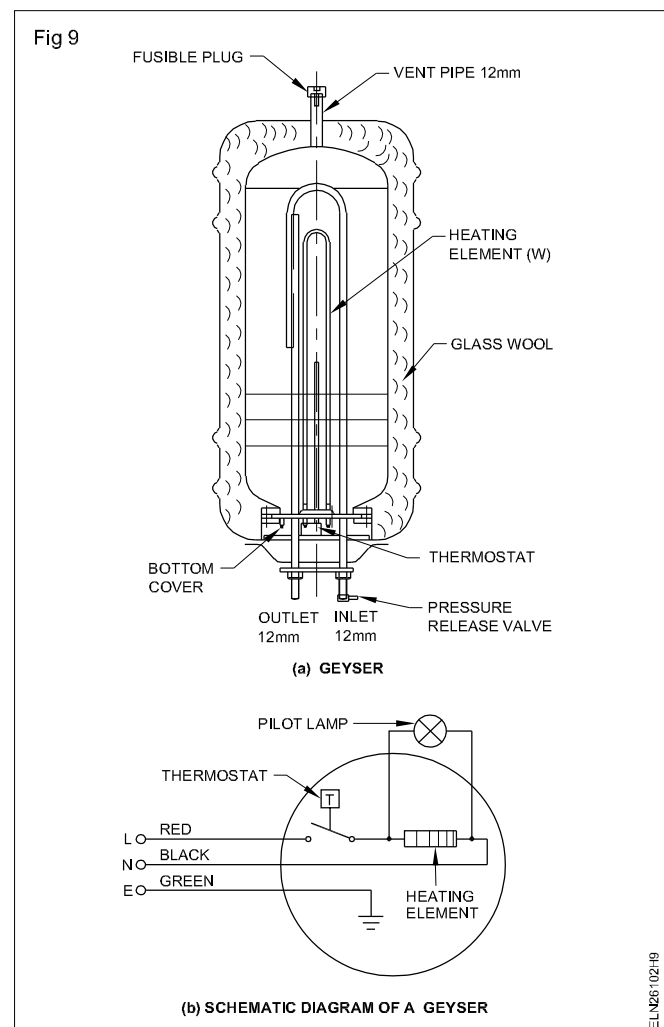

Table 2

Name of the appliance :		Serial No :	
Voltage :		Current :	
Supply :		Wattage :	
Capacity :		Make :	
Cord Insulation	Between lines	Between line/body	Date of servicing
 Megohm Megohm	
Element insulation	Between terminal and body / thermostat		Recommended Repair Replacement if any
	Cold		
	Hot		

Complaints

Listen to the complaints of the customer/user and note them. Proceed as stated below for the specific nature of fault complaint.

Nature of fault

1 No hot water : Check for the undermentioned causes in the given sequence.

- a No power
- b Defective thermostat
- c Thermostat out of calibration
- d Defective heater element

i) No power

Check the fuse of the circuit, and replace the fuse, if blown.

Check the availability of power at the socket outlet using a test lamp

Open the inspection cover and check the cord for its continuity. Replace the cord, if necessary.

Switch off the supply and remove the plug before opening the cover.

ii) Defective thermostat : Check the thermostat for continuity between its terminals at different settings. Replace the defective thermostat with a good one. No continuity between the terminals indicates defectiveness.

iii) Thermostat cut off calibration : Adjust the thermostat for a higher setting. If the thermostat is found to be good, switch ON supply. Observe the fuse.

iv) Defective element : Check the element for its continuity and insulation value between the terminal and the body (sheating of the element).

Replace the defective heating element with an identical good one . Switch on the supply and observe.

2 Water too hot

Check for the undermentioned causes.

- a Thermostat set too high

b Defective thermostat

- i) Check the setting of the thermostat and adjust it to a lower value. Switch on the geyser. Wait for the thermostat to cut off the supply, or for about 20 minutes. Open the inlet. Collect the water at the outlet and measure the hot water temperature.
- ii) If the water temperature is much higher than the set value of the thermostat, replace the thermostat with a good one. If the temperature of the hot water is close to the range setting of thermostat it indicates a defective setting as the only cause.

3 Water not hot enough

Check for the undermentioned causes.

- a Thermostat set too low
- b incorrect heater element
- c Excessive lime in tank
- i) check the thermostat setting and adjust it to a higher value. If the geyser produces hot water with the resetting, then the earlier setting was wrong.
- ii) Check and test the wattage of the heating element. If it shows a lower value, replace it with a higher wattage element.
- iii) Remove the heating element, inspect the element and the inner side of the copper vessel for deposit of excess lime coating. In case the heating element is of correct wattage, and the thermostat is properly set remove the lime coating.

Drain the water from the container of the geyser before removing the element.

Service and repair of induction heater and oven

- Objectives:** At the end of this exercise you shall be able to
- **dismantle the induction heater and identify or locate the faults**
 - **replace the faulty parts with good ones**
 - **dismantle the oven and identify or locate the faults**
 - **replace the faulty parts with good ones**
 - **assemble the induction heater and oven and test for its working.**

Requirements			
Tools / Instruments		Equipment / Machines	
• Electrician Tool Kit	- 1 Set	• Induction heater 1 kW, 250V	- 1 No.
• Screw driver 250 mm	- 1 No.	• Electric oven 1 kW, 250V	- 1 No.
• Connector screw driver 150mm	- 1 No.	Materials	
• Electrician Knife 150 mm	- 1 No.	• Cotton waste	- as reqd.
• Metal brush	- 1 No.	• Thinner	- as reqd.
• Soldering iron 60W, 230V	- 1 No.	• Resin core solder	- as reqd.
• Tile cutter	- 1 No.		
• Multimeter	- 1 No.		

PROCEDURE

TASK 1 : Service and repair of induction heater

- 1 Note the name plate details of the induction heater and record them in the Table.

Name Plate Details	
SL No. _____	Power _____KW
Make _____	1 ϕ / 3 ϕ
Voltage _____V	
Current _____A	

- 2 Disconnect the power supply from the induction heater.
3 Check the power cord for continuity of the cable

If found defective, replace the power cord

- 4 Open the induction heater.
5 Do a thorough cleaning of PCB and other parts.
6 Remove the main board for visual inspection and trouble shooting.
7 Check whether PCB is covered by varnish.
8 Apply thinner and rub with metal brush and scrap with a knife and expose the dry solder points. (Fig 1)
9 Retouch all the points with fresh solder.

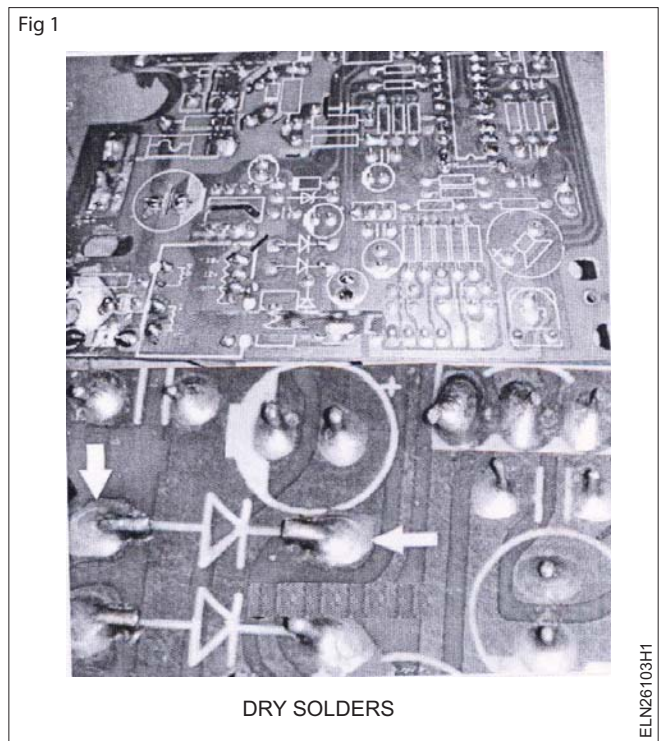

- 10 Check whether any capacitor cracked in the PCB (Fig 2). If so remove it from the PCB with the help of tile cutter (Fig 4) .
11 Check the electrolytic capacitors on the board and replace with a new one if they are found at the brim.

12 Press the switches on the control board and if they show resistance, it may be due to improper contact.

13 Replace all the Press-to-on button switches.

If buttons are slightly longer than the one on the board, nip the extra length with tile cutter tool

14 Defective switch is shown below (Fig 5)

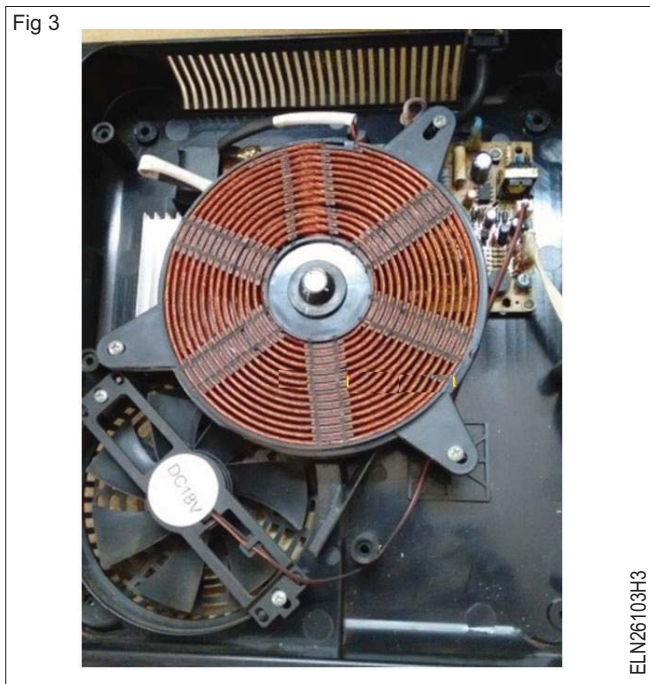
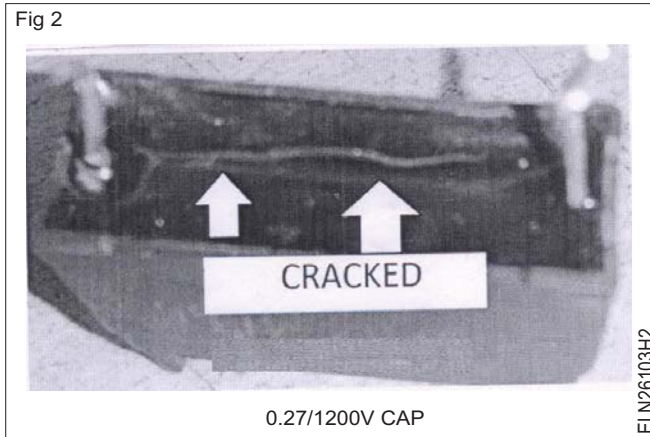

15 After completing the work put the PCB and other parts back into the cabinet, (Fig 3). Fig 6 shows the cook top of induction heater.

16 Test the appliances with supply for its working.

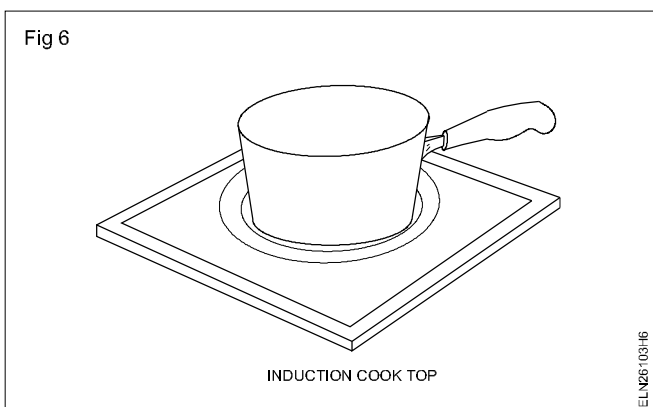
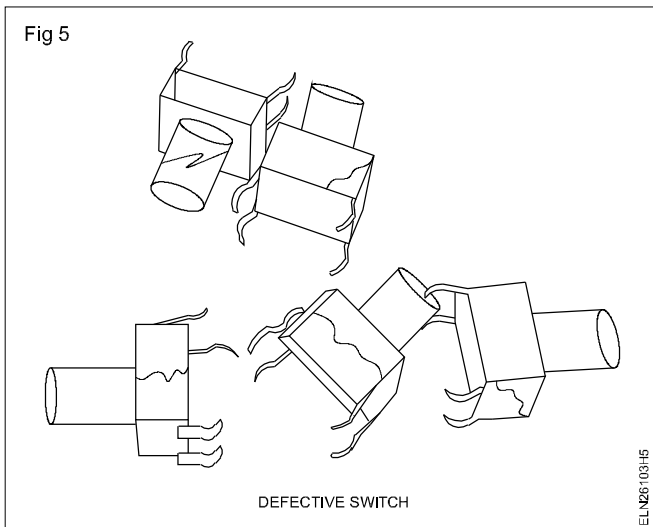
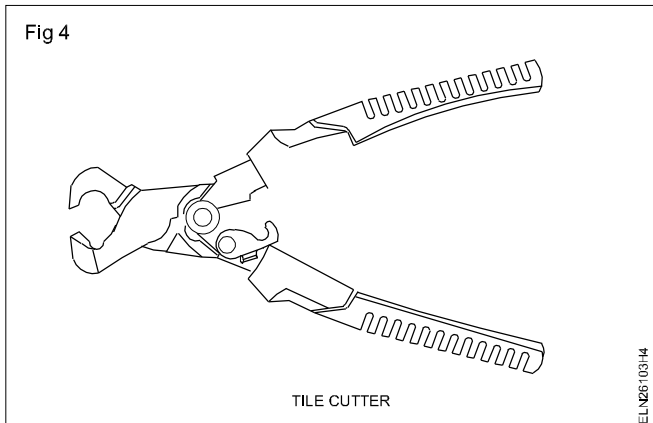

TASK 2 : Service and repair of oven

1 Identify the oven model number or part number on the element

The package (Fig 8b) of the new element will list the manufacturers, model numbers and part numbers for which it serves as a replacement

2 Turn off the power to the oven at the breaker box and unplug the oven

3 Remove the screws that secure the element to the oven

4 Pull the element 10 to 12.5 cms away from the back wall of the oven (Fig 7)

5 Remove the screws that hold the wires of element

6 Install the new oven element attaching the wires as they were before

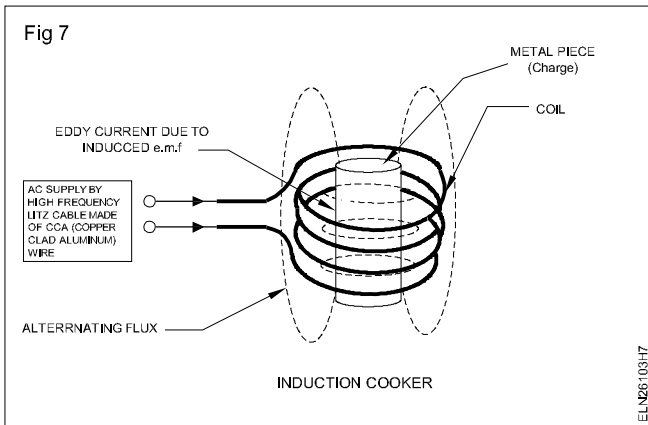

- 7 Secure the new element to the back wall of the oven (Fig 8a) shows element.
- 8 Plug the oven back in and return the breaker back to the "ON" position
- 9 Test the oven with supply for its working.

There may be little smoke when the new element heats up it's likely just the factory coating burning off.

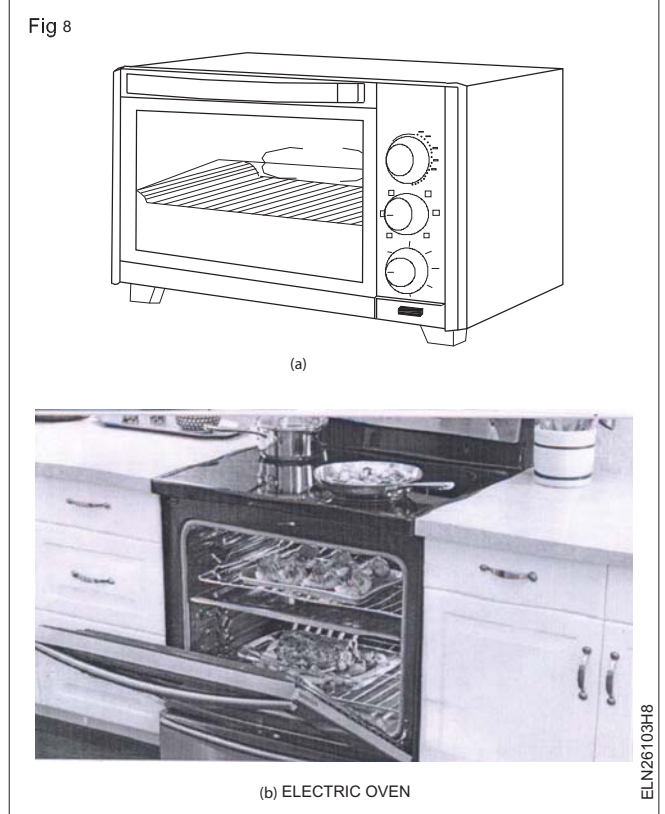

Service and repair of mixer and grinder

Objectives: At the end of this exercise you shall be able to

- read and interpret the data of the given mixer
- identify the area of problem in the mixer by visual inspection and tests
- dismantle the mixer
- trace, identify and locate faults in the mixer
- replace faulty parts with good ones
- clean and lubricate the bearings
- assemble mixer and test for its working
- read and interpret data of wet grinder
- test the line cord for continuity
- measure insulation resistance between the terminals
- trace, identify and locate faults in a wet grinder
- replace faulty parts with good ones.

Requirements

Tools and Instruments

- Electrician Tool kit - 1 Set
- Test lamp 100 W, 240 V - 1 No.
- D.E. spanner set of six 6 mm to 22 mm - 1 Set
- Plastic spanner for opening the jar screw - 1 No.
- Box spanner set of 6mm to 22 mm - 1 No.
- Multimeter - 1 No.
- Megger 500 V - 1 No.
- Philips screwdriver 4 mm blade dia - 1 No.
- Pulley puller 3leg 200 mm - 1 No.

Equipment / Machines

- Mixer 250 V 50 Hz. 400 watts - 1 No.
- Grinder 250 V 50 Hz 0.25 HP - 1 No.
- AC Ceiling Fan 60 W, 250V - 1 No.

Materials

- Grease/lubricating oil - as reqd.
- Kerosene - as reqd.
- Cleaning brush - 1 No.
- Sandpaper smooth - as reqd.
- Soldering lead, 40:60, soldering flux - as reqd.
- Service manual (if available) - 1 No.

PROCEDURE

TASK 1 : Service a mixer

- 1 Note down the name-plate details in the maintenance cards. (Table 1)
- 2 Enter the details of the complaint from the customer in the maintenance card.
- 3 Switch on the mixer and check for its functioning.
- 4 Isolate the mixer from the supply.
- 5 Open the bottom cover and conduct visual inspection for :
 - damages in the supply cord and loose terminal connections

- good condition of switches
- proper mounting of the motor.

Check whether the nylon/rubber coupling of the jar and motor are properly seated, if not replace.

Sometimes the retaining spring and washer might have got spoiled and need to be replaced.

Table 1
Maintenance Card

Name of the customer _____		Address _____	
Name of the appliance _____		Serial No _____	
Wattage _____	Current _____	Voltage _____	
Supply _____	Make _____		
Date of servicing	Consumer's complaint	Defects noticed by visual inspection	Details of repair and replacement

Enter the mixer details in the maintenance card (Table 1)

6 Conduct an insulation test of the motor and record in the maintenance card (Table 2). The schematic diagram of a mixer circuit is given in Fig 1.

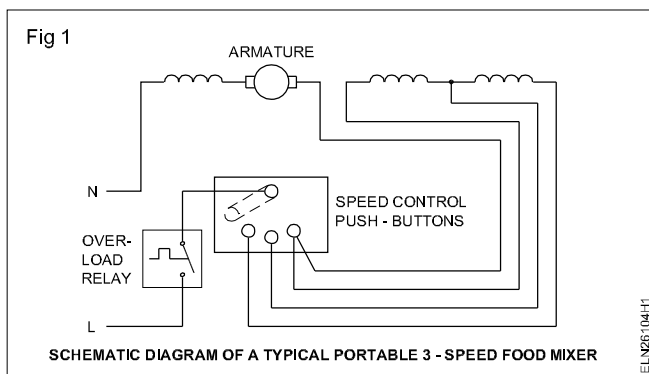

The insulation resistance value should not be less than one megohm.

- 7 Improve the insulation value by heating or varnishing, if the insulation value is less than one megohm and enter the test results in the maintenance card. (Table 2)
- 8 If the motor is opened for varnishing, clean thoroughly the stator and armature and bush bearings. (Fig 2)
- 9 Conduct the insulation test after varnishing and enter the results in the maintenance card (Table 2).

Remember that the nuts at the blades and the centre shaft holding nut are to be loosened by clockwise movement and tightened by anti-clockwise movement in most of the mixers.

- 10 Lubricate the bearing as recommended by the manufacturer before assembly.

Most of the bearings need no lubrication. If required, a drop of light oil like 3-in-1 oil could be used.

- 11 Clean the commutator surface. A black carbon deposit

Fig 2

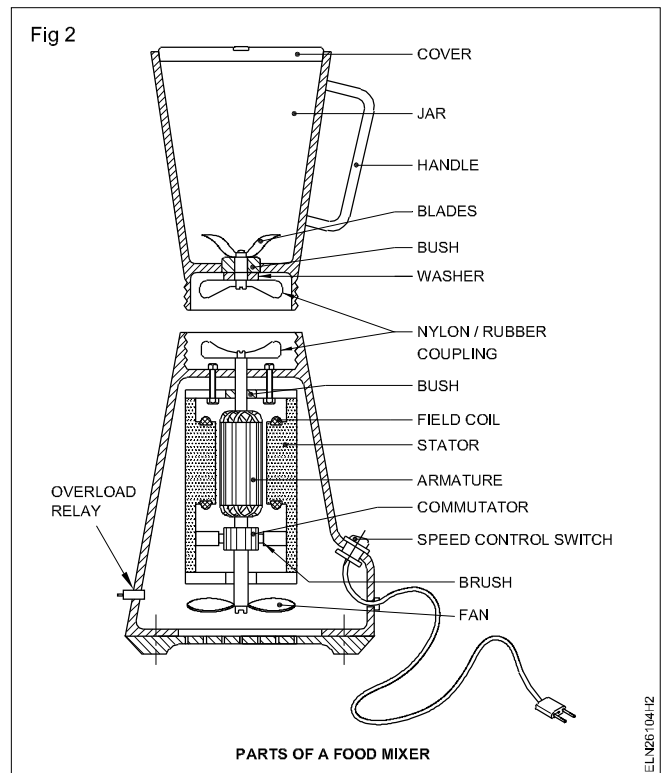

could be removed by CTC. Seat the bushes properly over the commutator. Check for adequate length of brushes to exert spring pressure.

If the brush length is shorter by 1/3 of its original length it is better to replace with the brushes of the same grade and size. The new brush has to be bedded on the commutator properly.

- 12 Assemble the motor and tighten the terminal screws.
- 13 Assemble the blade with the jar and nylon coupling at the bottom.
- 14 Connect the motor to the supply and start the mixer.
- 15 Observe the working of the mixer for smooth running.

Table 2

Date of servicing	Insulation resistance before varnishing/heating		Insulation resistance after varnishing/heating		Details for repair and replacment
	Between terminal and body	Between Armature and field	Between terminal and body	Between Armature and field	

TASK 2 : Repairing of mixer

1 Listen to the complaints of the customer/user and enter in the maintenance card (Table 1).

Common complaints are listed in the troubleshooting chart along with reasons for the possible cause and the corrective action to be taken.

2 Inspect visually the following parts for trouble.

- Power cord and plug
- Terminal connections at the switch (back cover to)
- Couplings
- Freeness of the shaft
- Burnt smell or discolouring of windings.

TASK 3 : Service a grinder

- 1 Switch on the grinder and check for its functioning.
- 2 Isolate the grinder from the supply.
- 3 Open the inspection cover. Note down the name-plate details in Table 3.

Table 3

Name of appliance _____	r.p.m _____
Serial No. _____	Volt _____
Capacity H.P _____	Current _____
Phase _____	Frequency _____

4 Conduct visual inspection:

- for supply cord
- for good condition of switches
- for proper mounting of motor and drive alignment (Fig 3)

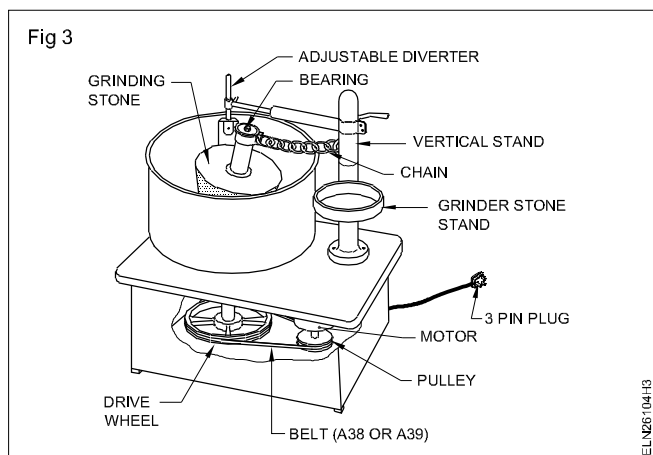

- 5 Conduct an insulation test of the motor and record in Table 4. If the insulation value is above 1 megohm, switch on the grinder and observe its function.
- 6 If the insulation resistance is less than 0.5 megohm, improve the insulation value by heating or varnishing, provided the motor is opened for varnishing.

Table 4

Insulation resistance	Between terminals and body	Between winding
Date of servicing		
Recommended repair		
Replacement if any		

- 7 Clean thoroughly the motor and the bearing of the grinder.
- 8 Lubricate the bearing as recommended by the manufacturer before assembly.
- 9 Assemble the motor and tighten the terminal screws, pulley screws, flywheel nuts, motor fixing bolts etc. (After adjusting belt tension)
- 10 Connect the motor to the supply and start the grinder. Observe the working of the motor and the grinder for smooth running.

TASK 4 : Repairing of grinder

- 1 Listen to the complaints of the customer/user complaints may be:
 - i) Grinder not working
 - ii) fails to start, but runs in either direction, when started manually
 - iii) starts but heats rapidly
 - iv) reduction in speed - motor gets too hot
 - v) grinder is noisy
 - vi) grinder gives shock.

Grinder not working

Check whether there is open connection in line. Rectify the fault if observed.

Check for any open circuit in motor winding (starting and running winding). Send it for repairs, if open circuited. (Fig 4)

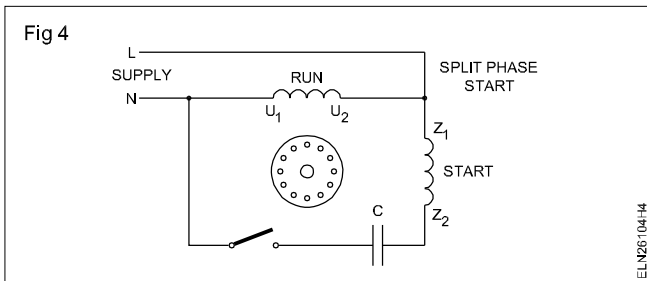

Check tightness of the belt. Adjust the belt for proper tension as recommended by the manufacturer. (Fig 3)

Check whether it is due to tight bearings. Test by turning the shaft by hand. If lubrication does not help, the bearing must be replaced.

Fails to start, but runs in either direction when started manually.

Check the contact of the centrifugal switch. If the contact of the centrifugal switch is not closed, repair it or replace it. (Fig 5)

Check the capacitor. Replace it if defective.

Starts but heats rapidly.

Check the centrifugal switch. If it is not opening, rectify or replace.

Reduction in speed - motor gets too hot.

Check the winding for its short circuiting and grounding (earthing).

Check the bearing to know whether it is sticky. Repair or replace, if found defective

Grinder is noisy

Check for worn out bearings - replace the bearings and inspect the shaft for scoring.

Check the end play, add additional end for preventing washers, if the play is too much.

Check the loose parts (that is loose hold-down bolts, loose fan, pulleys etc). Tighten them.

Check whether there is misalignment. Align the pulleys correctly. (Fig 3)

Check the belt. Replace if it is worn out. (Fig 3)

Check the shaft of the motor. Replace or send the motor for repair, if found bent.

Grinder gives shock

Open the inspection cover and check for any line contact with the metallic body. Also ensure earthing is proper.

Rectify the accidental contact, if any, and insulate them properly.

TASK 5 : Servicing on AC ceiling fan

- 1 Switch 'ON' the fan and check for its smooth functioning at different settings of the regulator.
- 2 Isolate the fan circuit from supply by
 - removing the circuit cut-out or
 - switching off the mains and removing the fuse units.
- 3 Conduct visual inspection
 - for good condition of switch
 - for proper mounting of regulator and firm fitting of knob.
- 4 Open the switch cover. Remove any external deposits, using a hair brush.
- 5 Check firmness of termination. Open the regulator and clean the inside with a brush. Check and adjust the contacts, terminations. (Fig 6)
- 6 Measure the insulation resistance between the outgoing terminal of the regulator and earth. (Fig 7) Record its value in Table 1.
- 7 Make arrangements to reach to the ceiling fan through stable means of elevation. (ladder, table etc. The safety of a person is of utmost importance. Fig 8)

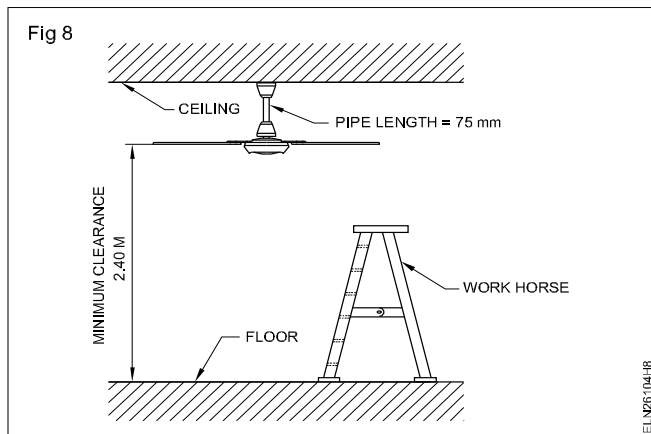
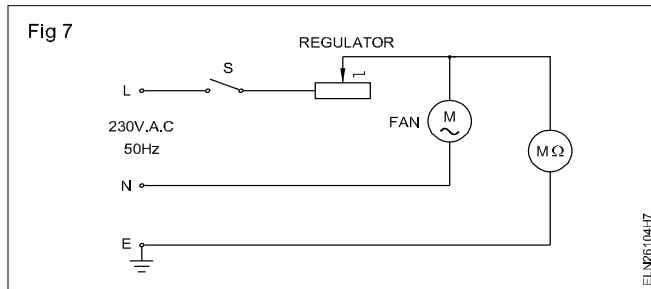
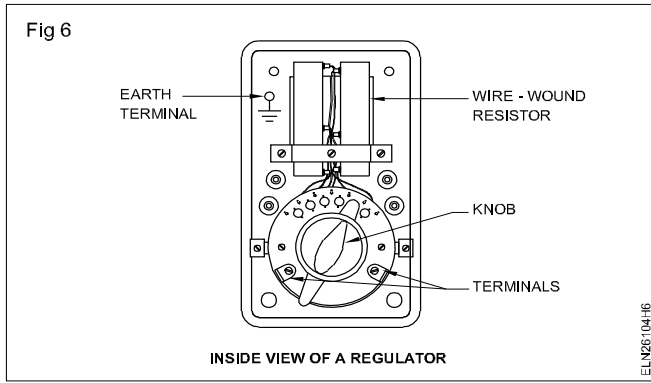

- 8 Note down the visual marking made on the fan, if any, and the name-plate details for filling up the entries in Table 5.
- 9 Remove the fan blades in succession and refit the screws and spring washers in their place, in the body of the fan.
- 10 Slide the top and bottom canopies for inspection and cleaning. (Fig 9)
- 11 Inspect the supporting hook, grommet, shackle, supporting system, split pin etc.

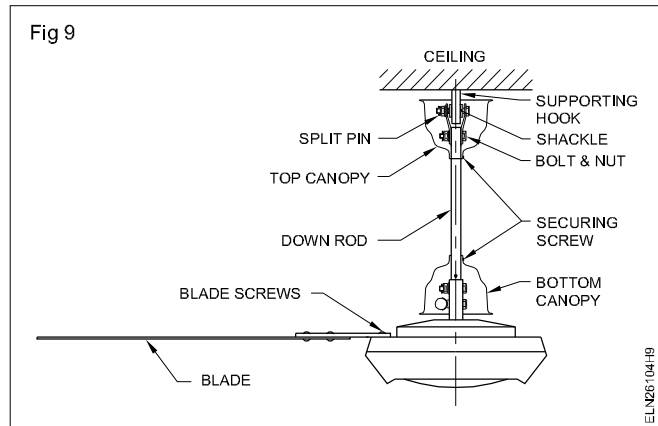

- 12 Inspect the cotter pin, check-nut, connections to the capacitor, fan leads, connector. (Fig 10) Clean the external dust, dirt with a brush.

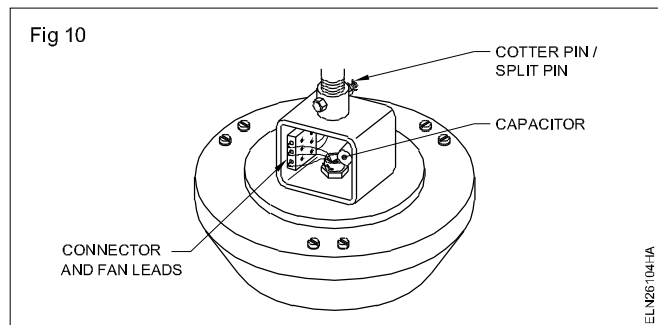

- 13 Clean the fan body first with a dry cloth and then with a wet cloth.

On inspection after sliding the canopy, if any excess of moisture or water is found, bring the fan down with the rod for testing its insulation resistance.

- 14 Dry the fan body by external heating with 500W or 1000W bulb or in an oven, if insulation is weak due to dampness.
- 15 Clean the blades thoroughly and mount them back. Apply grease/oil on the screws at the time of fixing the blade.
- 16 Test the fan for its smooth functioning, after resuming supply to the fan circuit.
- 17 Record your observations about the points listed in Table 6.

Table 5

Name of appliance	
Serial No.	Voltage
Sweep	Make
Supply	Current
Watts	Special marking
Insulation resistance between terminal & body	Megohms
Date of servicing	
Recommended repair/ replacement made, if any	

Table 6

Sl.No.	Points to be observed	Condition	
		Normal	Abnormal
1	Speed		
2	Noise		
3	Heat (after 10 min. run)		
4	Wobbling		
5	Function of regulator in all positions		

TASK 6 : Repairing of ceiling fan

Listen to the user's complaints. Complaints may be

- fan is not running
- fan is noisy
- fan wobbles excessively
- motor runs hot.

Fan is not running.

- 1 Check the concerned branch circuit fuse and ensure the availability of supply in the fan circuit.
- 2 Check for the supply in the outgoing lead from the regulator to the fan.

If any fault is noticed in the switch and/or regulator, rectify or replace it and ensure free rotation of the fan by rotating it manually.

- 3 Check the supply at the fan terminals (either at the fan terminals or at the ceiling rose).
- 4 Give temporary connection for further testing, if there is no supply at the ceiling rose.
- 5 Check the connection of the capacitor for loose connection after switching off the supply if the fan is still not running.
- 6 Switch ON the supply.
- 7 Replace the capacitor with an identical good capacitor, if the fan is not running.
- 8 Lower the fan if even after replacing the capacitor the fan is not running. Test winding and take the necessary repair work if needed.

Fan is noisy

- 1 Collect the history and nature of the noise of the fan from the user.
- 2 Run the fan and observe the noise.
- 3 Identify whether the noise is due to one or a combination of the following. (The parts are shown in Fig 11).
 - a Slack canopy - touching the rotating body.

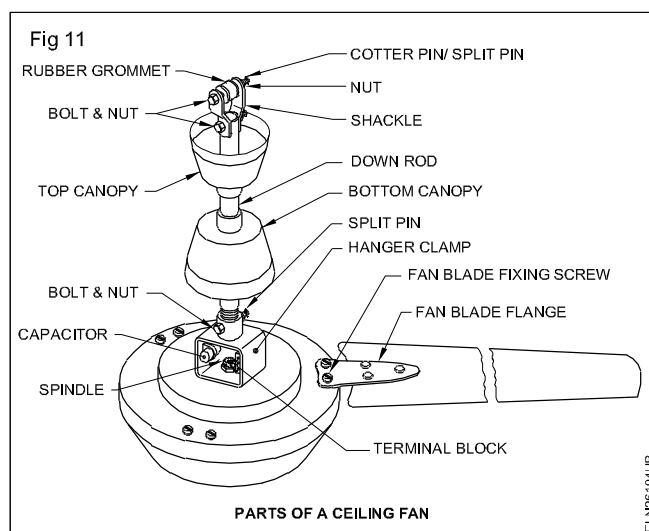

- b Worn out/partly out shackle.
- c Loose element of the blade.
- d Loose or missing screws.
- e Capacitor housing slack.
- f Broken or worn out split pin at the top and bottom.
- g Lack of lubrication, or dirt in bearing.
- h Worn out bearing/bush.
- i Blade distortion/breakage.
- j Alignment of blades.

Fan wobbles excessively.

- 1 Check to be sure that the screws which attach the fan blade flanges to the motor hub are tight.
- 2 Check to be sure that the fan blade flanges seat firmly and uniformly to the surface of the motor hub.

If the flanges are seated incorrectly, loosen the flange screws and re-tighten.

- 3 Tighten the hanger bracket screws to the junction box, secure the hook.
- 4 Interchange the adjacent (side by side) pair of blades.

If the fan blades are out of balance, it can redistribute the weight and result in smoother operation.

Motor runs hot

- 1 Check for partial short circuit in winding. If defective, send it for rewinding.

- 2 Check for tight bearing, if it is defective, replace it with good bearing.

Repeat the above steps for 3 different makes.

TASK 7 : Installation of ceiling fan

- 1 Cut/select the down rod length such that the blades remain at 2.4 to 2.7 m above the floor.

Do not mix the blades of one set with another set as the blades are matched as a set.

- 2 Slip in the canopies back to back through the down rod (Fig 11) and insert the connection wires.
- 3 Insert the down rod on the spindle and tighten with the bolt and nut separately packed with the hanger clamp. (Fig 11)
- 4 Remove the bolt and nut from the hanger assembly. (Fig 12)

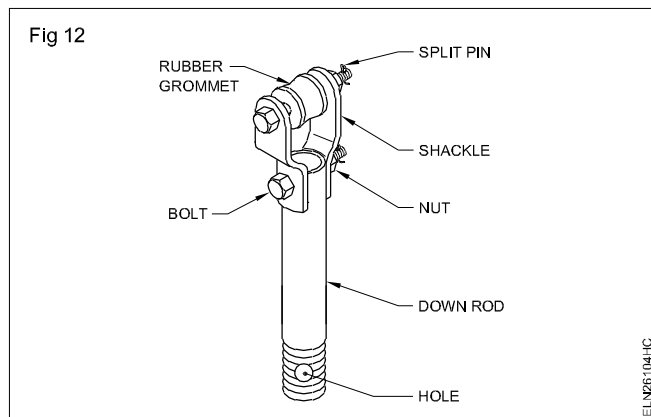

- 5 Insert the down rod top end in the hanger clamp assembly and tighten with bolt and nut.

Providing split pin, cotter pin at both ends of the down rod in a fan is a must to prevent falling of the fan by slackening of the bolt/nut securing.

- 6 Connect the wires to the terminal block, as per the instructions of the manufacturer.
- 7 Refit the bolt, nut with rubber shackle in the hanger clamp assembly.
- 8 Suspend the fan (without blades) by a pipe or rod inserted through the shackle as shown in Fig 13.
- 9 Connect it to the rated supply for a short while and observe for smooth running in the proper direction.
- 10 Mount the fan in the ceiling hook/supporting hook.

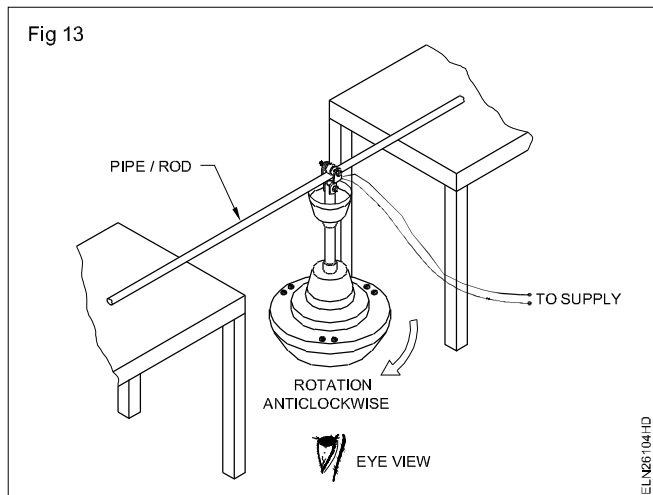

Ensure the split pin is inserted in the bolt and bent/ or the lock-nut is fitted.

- 11 Connect the wires to the ceiling rose. Slacken, slide and fix the canopies to cover the top hook and spindle terminals' block and capacitor.

Ensure that the canopies are fitted with sufficient spacing.

- 12 Fix the blade with the screws already provided on the motor.
- 13 Fix and connect the (Electronic) regulator between the fan switch and ceiling rose.
- 14 Test the fan for its working by connecting to the supply.
- 15 Check the speed control of the fan by varying knob of electronic regulator

If the electronic regulator is found faulty / defective it is better to replace it with new one instead of repairing it.

Service and repair of washing machine

Objectives: At the end of this exercise you shall be able to

- record the name plate details of the washing machine
- listen to the complaint of the customer and identify the type of fault
- rectify the fault in the washing machine
- service the washing machine through general checks and visual inspection
- conduct insulation resistance test on a washing machine
- record the details of maintenance in the service card.

Requirements			
Tools and Instruments		Equipment/Machines	
• Megger 500 V	- 1 No.	• Washing machine ordinary or semi automatic type 240V, 50Hz	- 1 No.
• Test lamp 60W,240V	- 1 No.	Materials	
• Combination plier 150 mm	- 1 No.	• Washing machine spares	- as reqd.
• D.E spanner set 6 of 22mm set of 8	- 1 Set	• Oil/grease	- as reqd.
• Philips screw driver 150 mm	- 1 Set	• Oil/grease	- as reqd.
• Grease gun 1.2 litre cap	- 1 No.	• Water proofing kit	- 1 No.
• Oil cane 1/2 litre cap	- 1 No.	• Teflon tape/m seal	- as reqd.
• Geal pulley puller 3 leg 150 mm	- 1 No.		
• Multimeter	- 1 No.		

PROCEDURE

TASK 1 : Repairing of washing machine

1 Record the details of the washing machine (Fig 1) in Table- 1.

Table 1

Name-plate details

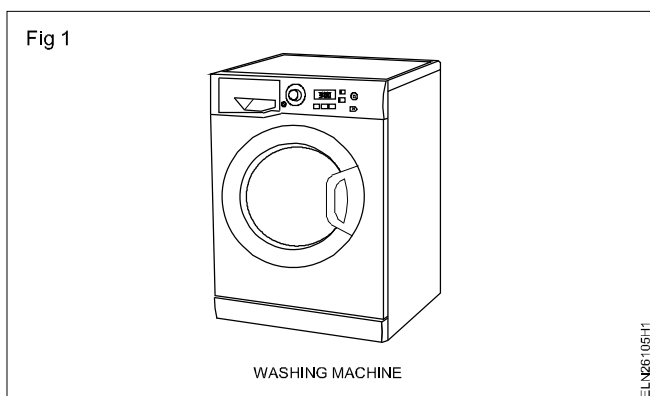

Manufacturer _____	
Sl.No. _____	Phase _____
Capacity _____	R.P.M _____
H.P/K.W _____	Voltage _____Hz
Max.weight _____	Current _____
of clothes/	
drum capacity _____	

2 Listen to the complaints of the customer/user. The complaints may be anyone listed in the left side column of the table 2 The causes and remedies are given in the right side column of the table 2

Table - 2

Troubleshooting chart for washing machine

Sl.No.	Complaints	Causes and remedies
1	Machine not Switching "ON"	<ul style="list-style-type: none"> I Check for open connection and rectify the same II Check the incoming supply III Check the fuse on the machine IV Check the motor windings and repair of minor repairs can be carried out, if needed send it for repairs/rewinding for internal open circuit. V Check the speed governing starting switch, repair or replace with a new switch.
2	Water not filling up in the washing drum	<ul style="list-style-type: none"> I The inlet pipe is choked. Open the inlet valve, clean it and reconnect it using water proofing teflon tape II Check incoming water supply and replace the same.
3	Water does not drain out of the wash drum	<ul style="list-style-type: none"> I Check the outgoing valve, clean and reconnect it with proper water proofing II Check the outgoing pipe for any kinks - repair or replace the same.
4	Machine does not switch 'OFF' after	<ul style="list-style-type: none"> I Check the timer working. The timing mechanism at pre-determined times set on the timer have been closed or clogged - if possible, repair it. Otherwise replace the timer with a new one. II The timer may be okay but the switch may be stuck -replace the switch.
5	Machine becomes 'ON only for a very short duration and then switches off	<ul style="list-style-type: none"> I The timer setting may be incorrect;set the timer properly. II The speed governor switch may be faulty; dismantle the motor and repair the same, If possible, or replace the starting speed governor swivel mechanism. III The running winding impedance could have increased due to open circuit and insulation failure. Check the running winding impedance and rewind the motor, if necessary.
6	The machine is noisy	<ul style="list-style-type: none"> I Check the balancing of the drum and correct the same if found off balance. II The motor shaft pulley/drum driver pulley may be loose,tighten the same. III The belt of the machine drive might have loosened thus giving play. IV Check the bearings of the motor, replace the worn out or grease the same using the recommended grease. V Check all rubber bushings that are used in the machine for absorbing mechanical vibration, and replace, if found spoilt or missing.
7	The machine gives shock	<ul style="list-style-type: none"> I Isolate the machine from the supply and carry out megger test II If there is an insulation failure found in the plug, isolate the motor and check the winding with body. III If winding insulation failure is detected, send the motor for rewinding. IV If insulation failure is detected, trace the complete wiring of the machine and locate the faulty or leaky insulation area. V Replace the complete wire that is found faulty

- 6 Lubricate the bearings of the motor with a suitable grease as recommended by the manufacturer with the help of the grease pump.
- 7 and especially where maximum vibration of the machines is felt, use a dot of grease or oil in the threads.
- 8 Conduct an insulation test of the motor and record it in Table 3, using a 500V Megger. Insulation resistance should be around 1 megohm; if found less then check the wiring and internal accessories and all Powerly live parts for moisture and weak insulation. Remove the moisture and prevent any water leakage near the Power parts suitably. Reconduct the insulation test.

- 9 Close the inspection hatch/cover and connect the machine to the supply and load the machine with the number of clothes recommended by the manufacturer for the smooth running of the washig machine.

Table 3

Insulation resistance between terminal & body windings	
Date of servicing	
Recommended repair	
Replacement of parts	

Verify terminals identify components and calculate transformation ratio of single phase transformers

Objectives: At the end of this exercise you shall be able to

- read and interpret the details of the name-plate of single phase transformer
- identify H.T & L.T. winding
- determine transformation ratio (turns ratio) by the
 - voltmeter method
 - ammeter method.

Requirements	
Tools/Instruments	Materials
<ul style="list-style-type: none"> • Voltmeter M.I. 0 - 250/300V - 2 Nos. • Ohmmeter (0 - 500 ohms) - 1 No. • Ammeter M.I. type (0 - 10 Amp) - 1 No. • Ameter M.I. 100 mA - 1 No. • Voltmeter M.C. 0-15V - 1 No. 	<ul style="list-style-type: none"> • Knife switch DPST 16A 250V - 1 No. • Push-button 6A, 250V - 1 No. • Connecting cables - as reqd.
Equipment/Machines	
<ul style="list-style-type: none"> • D.C. supply 12 volts - 1 No. • Single phase transformer 115/230 volts, 1KVA - 1 No. • Auto-transformer (IP-240V) OP 0-270V, 5A - 1 No. 	

PROCEDURE

TASK 1 : Identification of terminals

1 Find out the corresponding terminals of two windings (H.T. & L.T) with ohmmeter as shown in Fig 1, by checking the continuity.

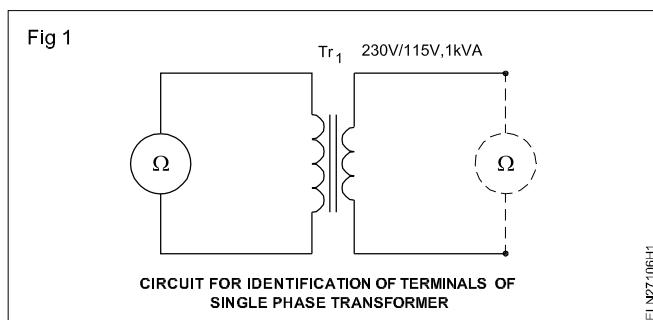

2 Determine HT and LT winding by measuring resistances with the ohmmeter.

L.T. windings will have low resistance in the case of step down transformer.

Record resistance of both pairs.

1st pair _____ ohms. This is HT/LT winding.

2nd pair _____ ohms This is HT/LT winding.

3 Connect DC supply to HT through push-button switch and connect the voltmeter to LT as shown in Fig 2.

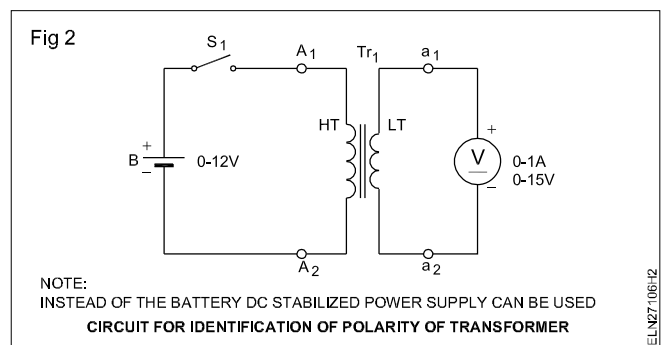

4 Mark HT terminals as A_1 and A_2 . Mark at LT terminals as a_1 and a_2 .

5 Press the push-button switch. Observe the deflection of the pointer of the voltmeter. If the pointer deflects in the right direction, retain the markings made on terminals.

6 Change the voltmeter connections made to LT terminals and change the marking made on the LT terminals if the deflection is in the reverse direction. Now press the push-button switch once again and observe that the voltmeter deflects in right direction.

TASK 2 : Verification of transformation ratio (by voltmeter method)

- 1 Connect the auto-transformer and the voltmeters to the transformer as shown in Fig 3. Check and set the auto-transformer at zero volt output position.

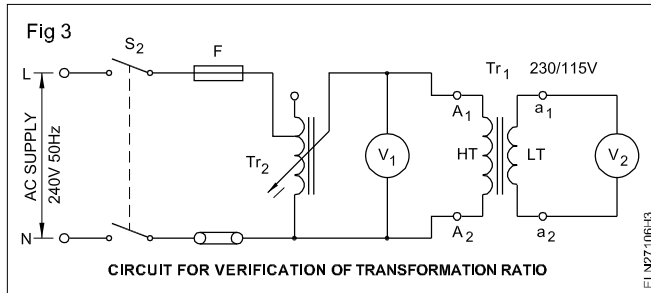

- 2 Switch on 'S₂' and adjust the autotransformer to get the output voltage V₁ = 100 volts and read V₂ record the value in Table 1.

The output voltage of the auto-transformer should be adjusted to about 50% of the rating of the H.T. side.

- 3 Set the V₁ value for the values indicated in Table 1 and record the corresponding readings of V₂ in Table 1.

- 4 Calculate the transformation ratio from the measured V₁ & V₂ values.

Applying the formula -

$$\text{Transformation ratio} = \frac{V_2}{V_1}$$

Table 1

Sl. No.	V ₁	V ₂	Transformation ratio K=V ₂ /V ₁
1	100 Volts		
2	125 Volts		
3	150 Volts		
4	200 Volts		
5	225 Volts		

- 5 Compare the calculated transformation ratio with the transformation
- 6 Transformation ratio calculated
from measurements =
from markings =

TASK 3 : Verification of transformation ratio (by ammeter method)

- 1 Connect the auto-ransformer output to the transformer H.T. winding through a milliammeter in the line as shown in Fig 4.

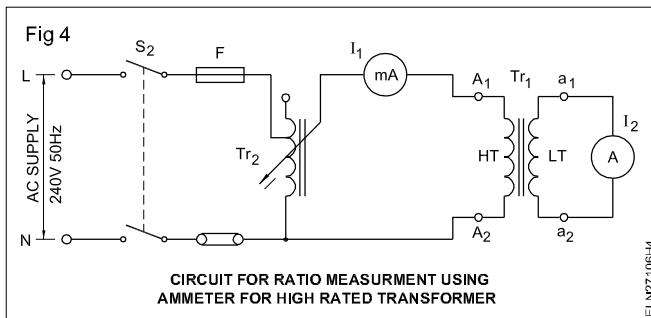

The current in the H.T. winding should be kept low, but should be large enough to be measured accurately with a milliammeter.

- 2 Connect the L.T. winding to the ammeter. The ammeter should carry the rated current of L.T. side.

Use the current transformer and ammeter if the secondary rating is very high.

- 3 Increase the voltage to give the required current in H.T. winding.
- 4 Read the L.T. current. Record in Table 2.
- 5 Change the H.T. current to different values and record the corresponding L.T. current.

Table 2

Sl. No.	I ₁	I ₂	Transformation ratio K=I ₁ /I ₂
1			
2			
3			
4			

- 6 Verify the transformation ratio with the markings on the name-plate and record your findings.

Perform open circuit and short circuit test to determine the efficiency of single phase transformer

Objectives: At the end of this exercise you shall be able to

- **conduct open circuit test to determine iron or core loss**
- **conduct short circuit test to determine full load copper loss**
- **determine efficiency of the transformer at different loads.**

Requirements	
<p>Tools/Instruments</p> <ul style="list-style-type: none"> • Voltmeter M.I. 100V - 1 No. • Voltmeter M.I. 150V - 1 No. • Wattmeter 250V, 5A - 1250W - 1 No. • Ammeter M.I. 5A - 1 No. • Ammeter M.I. 15A - 1 No. • Frequency meter 45 to 55Hz. - 1 No. • Power factor meter 0.5 lag -1-0.5 lead 250V rating - 1 No. 	<p>Equipment/Machines</p> <ul style="list-style-type: none"> • Transformer 100/250V 1 kVA 50 Hz - 1 No. • Auto-transformer input 240V Voutput 0 to 270V, 5A - 1 No. <p>Materials</p> <ul style="list-style-type: none"> • Knife switch DPST 16A, 240V - 1 No. • Connecting cables - as reqd.

PROCEDURE

TASK 1 : Conduct open circuit test to determine iron or core loss

- 1 Identify the LT and HT windings of the given transformer.
- 2 Connect the Auto-transformer, frequency meter, ammeter, wattmeter. Voltmeter to the LT side of the transformer as shown in Fig 1.

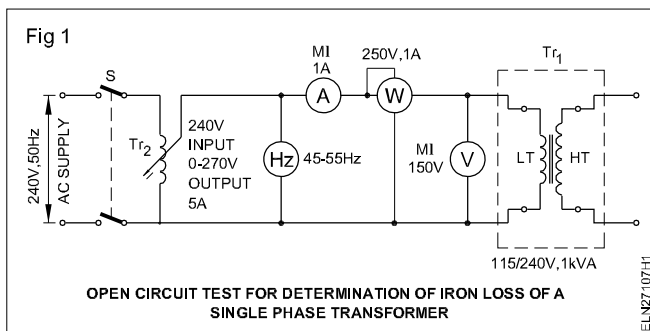

Increase the voltage slowly up to (100%) of the rated value of the transformer L.T.

- 4 Check for the supply frequency is at rated value.
- 5 Observe the meters and record the readings in Table.
- 6 Repeat the above steps for 110% rated value of transformer voltage and record the readings in Table.

TABLE

Sl.No.	Rated	Voltage V	Current A	Total Iron loss W
1	100%			
2	110%			

Ensure that the auto-transformer is initially set at zero volt output position.

From the above data the No Load Loss is equal to iron loss. Since the copper loss is negligible.

- 3 Close the switch 'S'.

TASK 2 : Conduct short circuit test to determine full load copper loss of a transformer

Short circuit test

- 1 Connect the auto-transformer, ammeters, voltmeter and wattmeter in the HT side of the transformer as shown in Fig 2.

Ensure the auto-transformer is initially set at zero volt output position.

- 2 Close the switch 'S'

The secondary is short circuited by the ammeter.

- 3 Increase the voltage gradually to obtain full load current in the secondary winding of the transformer.
- 4 Observe the wattmeter and record the readings.
W = Copper loss (full load).

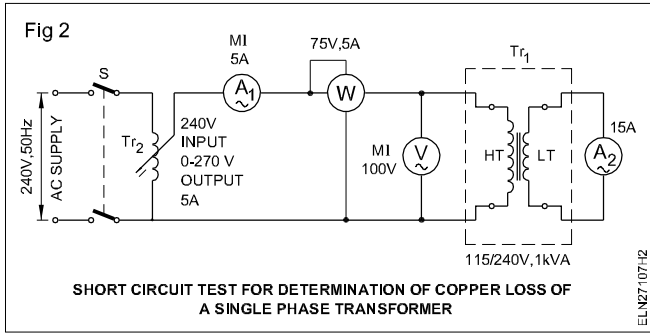

TASK 3 : Determine efficiency of transformer or different loads

- 1 Prepare and draw the circuit diagram for the said task and get approved by your instructor.
- 2 Collect the equipments and materials and check their condition.
- 3 Connect the circuit as per the approved circuit diagram (Fig 3).

Keep the switches s₁ and s₂ open. Set the auto transformer for zero volt output.

- 4 Close switch S₁ and gradually increase the output of the auto-transformer to reach the rated voltage.

Keep all the switches in the lamp bank in 'off' position.

- 5 Close switch S₂ and switch 'on' the incandescent lamps one by one till ammeter A₂ reads 25% of the load.
- 6 Adjust the auto-transformer Tr₂ if necessary to keep the primary voltage constant.

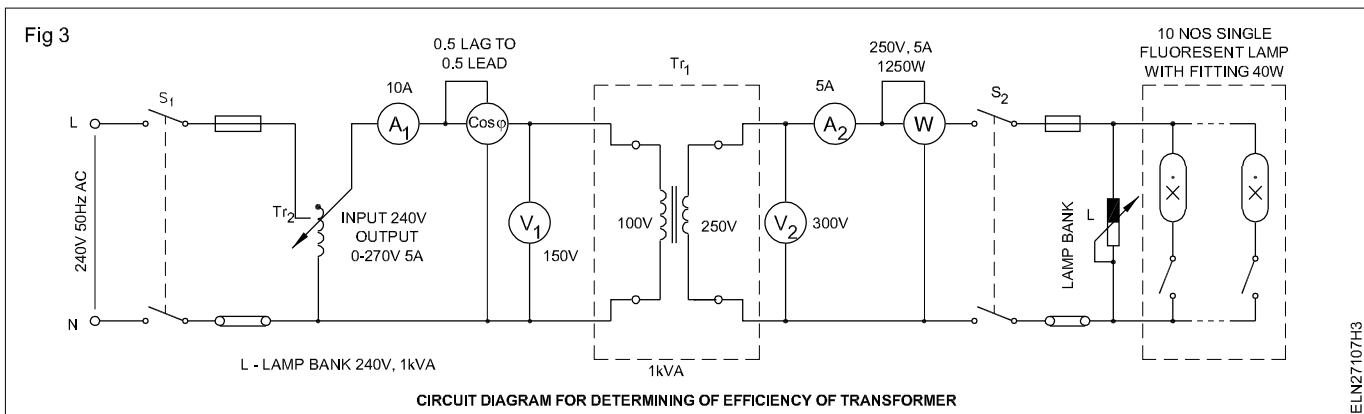

- 7 Record the readings of the instruments in Table 1.
- 8 Increase the incandescent lamp load to 50% of the full load 75% of the full load and 100% of the full load and record the reading in each case.
- 9 Repeat the above steps by switching on the tube lights to get a power factor of about 0.9, 0.8 and 0.7 and record the readings in Table 2.
- 10 Switch 'OFF' supply after bringing the knob of the auto transformer to minimum (zero) position.

- 11 Calculate the efficiency using the formula

$$\text{Percentage efficiency} = \frac{\text{Output}}{\text{Input}} \times 100 \text{ OR}$$

$$\text{Percentage efficiency} = \frac{\text{Output}}{\text{Output} + \text{losses}} \times 100$$

$$= \frac{W}{W + W_1} \times 100$$

where W₁ = Iron loss + copper loss.

Table - 1
(Unity P.F)

Sl.No.	Load	V ₁	A ₁	P.F (Cos φ)	V ₂	A ₂	W	% Efficiency $= \frac{W}{V_1 A_1 \cos \phi} \times 100$
1	No load							
2	1/4th load							
3	1/2 load							
4	3/4 load							
5	Full load							

Table - 2
(Different P.Fs)

Sl.No.	Load	V ₁	A ₁	P.F (Cos φ)	V ₂	A ₂	W	% Efficiency $= \frac{W}{V_1 A_1 \cos \phi} \times 100$
1	No load							
2	1/4th load							
3	1/2 load							
4	3/4 load							
5	Full load							

12 Complete the tasks and get approved by your instructor and disconnect the circuit.

Conclusion

- 1 The relationship between load and efficiency _____
- 2 The relationship between power factor and efficiency _____
- 3 The efficiency will be maximum when _____

Determine voltage regulation of single phase transformer at different loads and power factors

Objectives: At the end of this exercise you shall be able to

- connect the transformer with suitable instruments to measure load and power factor
- calculate the regulation of single phase transformer from the readings of instruments in primary and secondary side.

Requirements	
Tools/Instruments	Materials
<ul style="list-style-type: none"> • Ammeter M.I.-0 to 5A, 0 to 10A each - 1 No. • Voltmeter M.I.-0 to 300 V, 0 to 150 V each - 1 No. • P.F.meter 0.5 lag -1 - 0.5 lead 250 V rating - 1 No. 	<ul style="list-style-type: none"> • Connecting cable - as reqd. • 40 watts-tube light fitting - 10 Nos. • DPST switch 250V 16A - 2 Nos. • SPT switch 6 A - 2 Nos.
Equipment/Machines	
<ul style="list-style-type: none"> • Induciton motor with starter & loading arrangement 240V 50Hz 1 HP - 1 No. • Auto-transformer Input 40V Output 0 to 270 V, 5 amps - 1 No. • Single phase transformer 115/230V 1 kVA, 50 cycle air cooled - 1 No. • Lamp bank 5 A, 250V - 1 No. 	

PROCEDURE

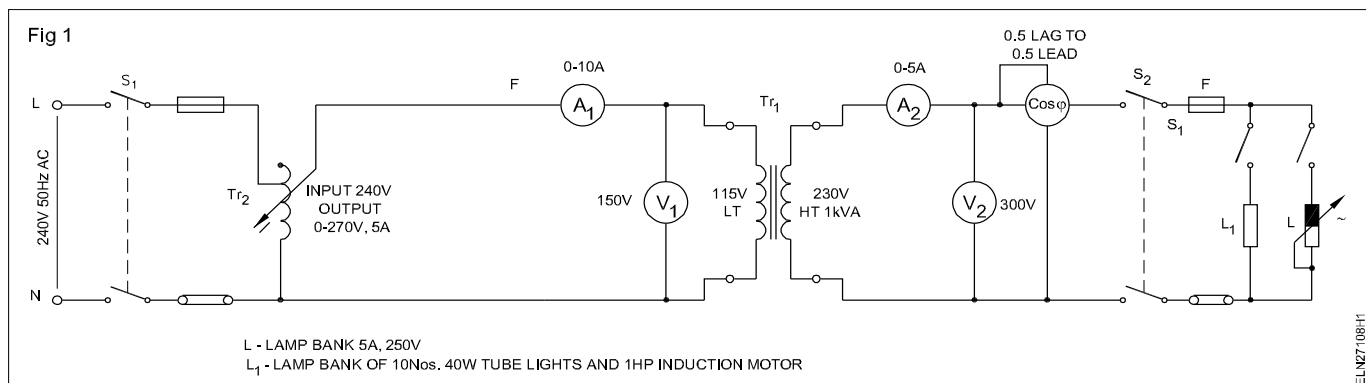

- 1 Form the circuit as shown in Fig 1.
- 2 Note down the name-plate details of the transformer. (Table 2)

Table 1

Sl. No.	Load (Lamp)	Secondary Terminal Voltage V_s	Change of volts $V_o - V_s$	Regulation
1	No load V_o			
2	1/4 F.L.			
3	1/2 F.L.			
4	3/4 F.L.			
5	F.L.			

Check the auto-transformer T_{r2} is set at zero volts output position.

- 3 Switch on 'S₁' and adjust the voltage of primary to rated secondary voltage (V_o) of transformer.
- 4 Close the load switch S₂
- 5 Adjust the lamp load as indicated in Table 1 and record the secondary voltages at each load. (V_s)
- 6 Calculate % of regulation at different resistive loads.

$$\left(\% \text{ of regulation} = \frac{V_o - V_s}{V_s} \times 100 \right)$$

- 7 Put the inductive load with lamp bank (mixed load) so that the load power factor is lagging.

Perform series and parallel operation of two single phase transformers

Objectives: At the end of this exercise you shall be able to

- conduct the polarity test of the transformer (R)
- connect two single phase transformers in parallel
- connect two single phase transformers secondary in series.

Requirements			
Tools/Instruments		Materials	
• Voltmeter MI, 150V	- 1 No.	• ICDP switch 16A 250V 50Hz	- 4 Nos.
• Voltmeter MI, 300V	- 2 Nos.	• Connecting cables	- as reqd.
Equipment/Machines			
• Single phase transformer 230/115V, 1 KVA 50 H1.	- 2 Nos.		
• DC supply 12V/Battery 12V	- 1 No.		

PROCEDURE

TASK 1 : Connect the transformer secondary in series

1 Connect the transformer as per diagram. (Fig 1)

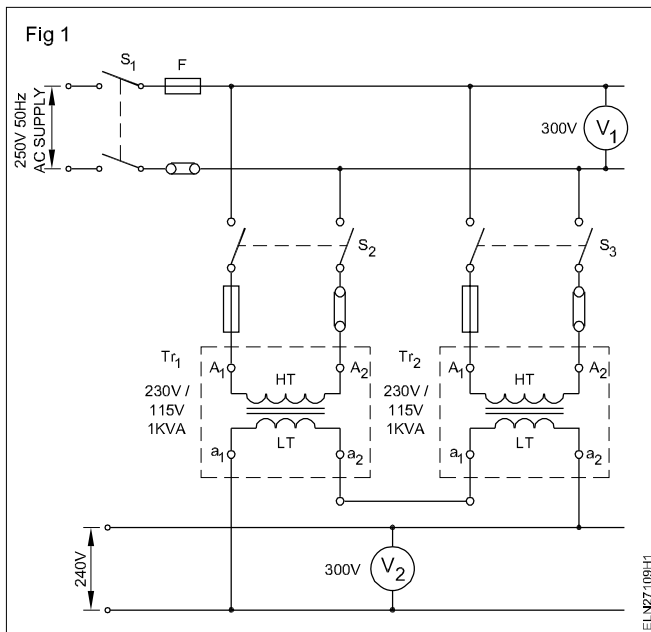

2 Close the switches S_1 , S_2 and S_3 .

3 Measure the primary voltage V_1 and secondary voltage V_2 and record in Table 1

Table 1

Transformer in series		
	Primary V_1	Secondary V_2
Tr_1		
Tr_2		

4 Disconnect the transformers by opening S_3 , S_2 and S_1 .

Table 2

SI. No. <input style="width: 80%;" type="text"/>		Type of cooling <input style="width: 80%;" type="text"/>	
KVA <input style="width: 80%;" type="text"/>		Frequency <input style="width: 80%;" type="text"/>	
AT NO LOAD VOLTS	HT <input style="width: 80%;" type="text"/>	Date of MFG <input style="width: 80%;" type="text"/>	
	LT <input style="width: 80%;" type="text"/>		
AT NO LOAD CURRENT	HT <input style="width: 80%;" type="text"/>		
	LT <input style="width: 80%;" type="text"/>		

TASK 2 : Connect the transformer in parallel

- 1 Read and record the name-plate details of both the transformers, Tr_1 & Tr_2 in table 2.
- 2 Determine the polarity of the two given transformers.
- 3 Connect the switches, transformers and meters as per diagram. (Fig 2)

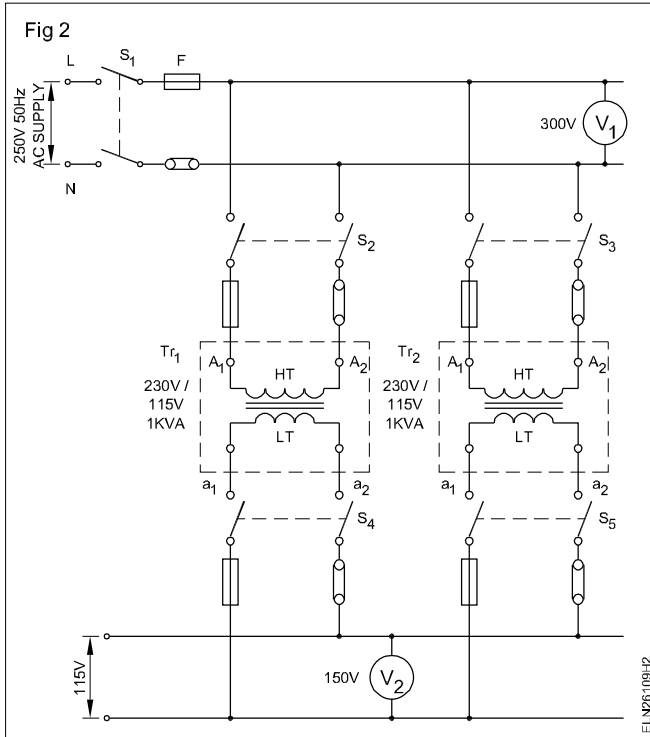

- 4 Keep all the switches open.
- 5 Ensure that the transformers are identical for parallel connections.
- 6 Connect transformer Tr_1 to the bus bar closing the switches S_1 & S_2 . Measure the primary voltage V_1 and record in Table 3

Table 3

Transformer in parallel		
	Primary V_1	Secondary V_2
Tr_1		
Tr_2		

- 7 Check the secondary voltage of Tr_1 and record it table 2.
- 8 Close the switch S_3 and check the secondary voltage of the transformer Tr_2 and record. (Table 2)
- 9 Close the switch S_4 and S_5 and measure the secondary bus bar voltage and record in table 3.
- 10 Switch off all the switches and disconnect both the transformers.

CONCLUSIONS

- 11 The effect on secondary voltage of transformers when connected in series is

- 12 The effect on the secondary voltage of transformers when connected in parallel is

Verify the terminals and accessories of three phase transformer HT and LT side

Objectives: At the end of this exercise you shall be able to

- read and interpret the name plate details of a three phase transformer
- verify the terminals of HT and LT winding
- Identify the accessories of a three phase transformer.

Requirements			
Tools/Instruments		Equipment/Machines	
• DE Spanner Set 5mm to 20mm	- 1 Set	• 3 - Phase transformer 415/240V, 3 KVA	- 1 No.
• Insulated cutting pliers 200mm	- 1 No.	• 3 - Phase transformer Input 415 V Output 0-500 V, 3 kVA	- 1 No.
• Screw driver 200mm	- 1 No.		
• M.I.voltmeter 0-500 V	- 1 No.	Materials	
• Multimeter	- 1 No.	• Test lamp 40 W, 230 Volts	- 2 Nos.
		• Connecting leads	- as reqd.

PROCEDURE

TASK 1 : Verify the terminals of three phase transformer

- 1 Note down the name plate details and enter in Table 1

Table 1

Name plate details			
SINo	: _____	Type of cooling	: _____
KVA	: _____	Mass of Coil	: _____
Volts HT	: _____	Total mass	: _____
LT	: _____	Date of MFG	: _____
Amps HT	: _____	Volume of oil	: _____
LT	: _____		
Frequency	: _____		

- 2 Check the continuity test using a multimeter to find out the two groups of terminals. (Fig 1)
- 3 Apply 15V 3 ϕ supply to U_1 , V_1 and W_1 by switching on switch 'S'.
- 4 Measure the voltage between V_2 and W_2 and between V_2 and U_2 . If the voltmeter shows less than 15 volts then those windings are LT winding. If the voltmeter shows more than 15 Volts then those windings are HT winding. (Fig 2)

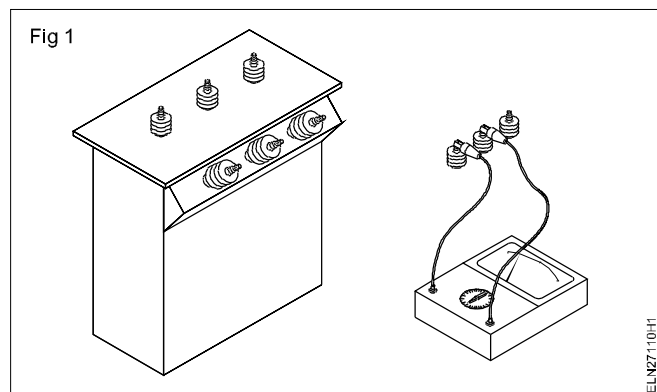

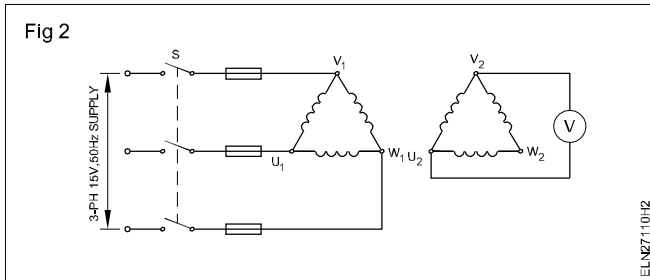

TASK 2 : Identify the accessories of 3 phase tranformer

- 1 Get permission to enter the 11 KV transformer substation yard from the appropriate authority
- 2 Identify the following accessories of a 100KVA three phase transformer. (Fig 3 and 4)
 - a HV & LV Bushing
 - b Buchholz relay
 - c Conservator
 - d Breather
 - e Cooling pipes
 - f Explosion vent with oil gauge
 - g Earthing terminals
 - h Oil level indicator.

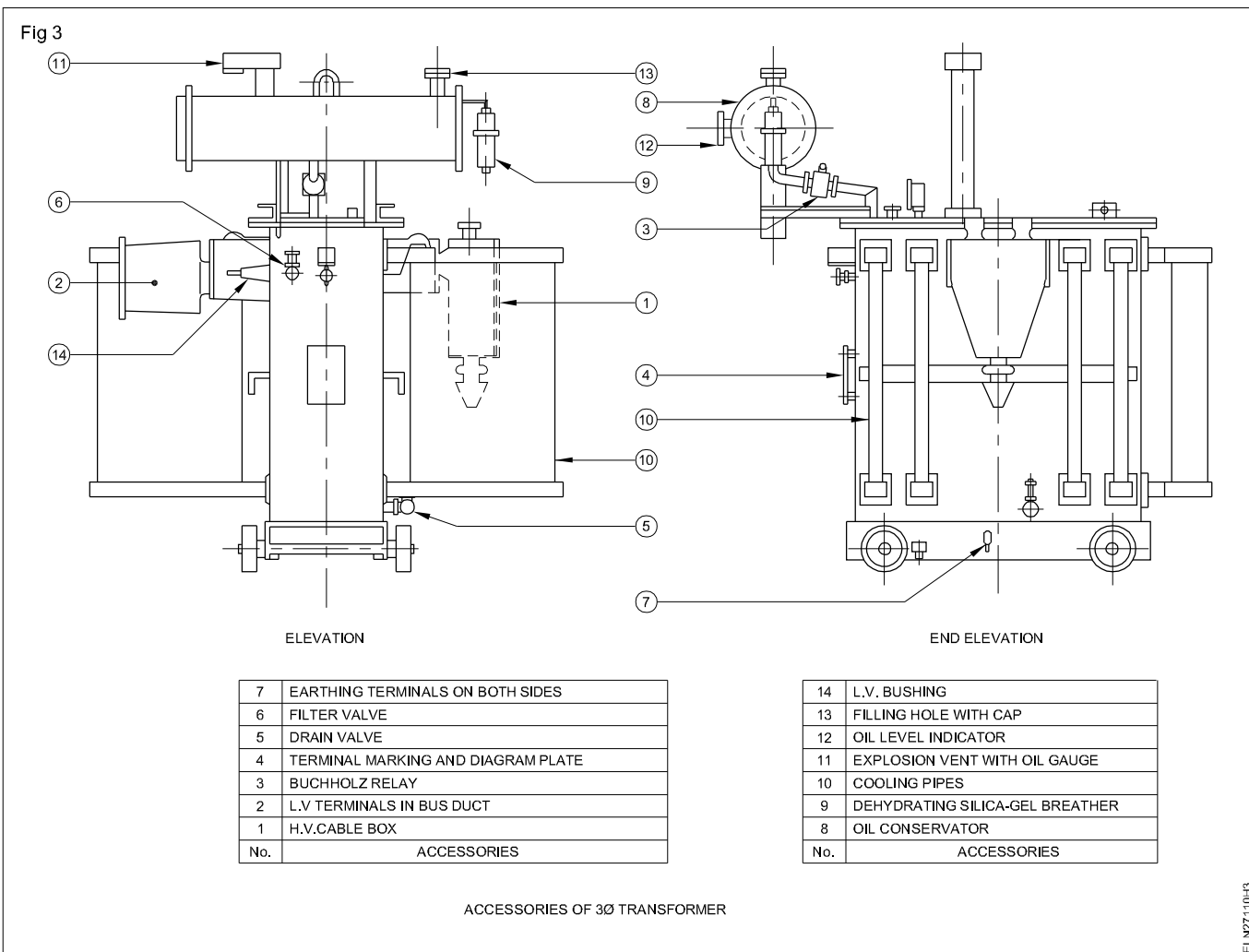
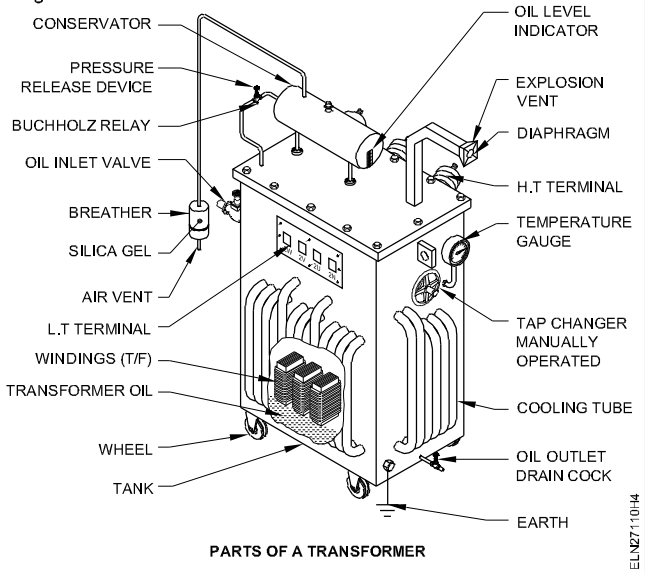

Fig 4



Perform 3 phase operation (i) delta - delta (ii) delta - star (iii) star-star (iv) star - delta by use of three single phase transformes

Objectives: At the end of this exercise you shall be able to

- connect three single phase transformers to 3-phase supply with different types of primary and secondary connection
- measure the primary and secondary line voltages in each type of connection
- determine the line voltage ratio and compare with the theoretical ratio values.

Requirements			
Tools/Instruments		Materials	
• Electrician tool kit	- 1 No.	• Connecting cables	- as reqd.
• Voltmeter M.I. - 0 to 500V	- 1 No.	• ICTP switch 500V, 16A,	- 2 Nos.
• Voltmeter M.I. - 0 to 300V	- 1 No.	• HRC fuses, 2 Amp	- 3 Nos.
Equipment/Machines			
• Single phase transformer 1 kVA 415/230 V 50Hz	- 3 Nos.		

PROCEDURE

- 1 Connect the three single phase transformers and perform polarity test and voltage ratio test.

Note down the voltage ratio of each transformer in the table.

All the three transformers should have the same voltage ratio and same primary and secondary voltages.

- 2 Mark the terminals of the primary (HT) and secondary (LT) of each single phase transformer as follows.

The Terminal Marking are as per Standards

Terminals	Transformer 1	Transformer 2	Transformer 3
Primary (HT)	1U	1V	1W
	Starting Ending	Starting Ending	Starting Ending
	1.1 1.2	1.1 1.2	1.1 1.2
Secondary(LT)	2U	2V	2W
	Starting Ending	Starting Ending	Starting Ending
	2.1 2.2	2.1 2.2	2.1 2.2

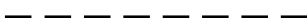

TASK 1 : To connect the transformers as three phase delta-delta transformer

- 1 Connect the dissimilar ends of the primary together. i.e. (Fig 1)
 Connect 1.1. of Tr.1 with 1.2 of tr.3 and mark it as 1 U
 Connect 1.2. of Tr.1 with 1.1 of tr.2 and mark it as 1 V
 Connect 1.2. of Tr.1 with 1.1 of tr.3 and mark it as 1 W
- 2 Connect the dissimilar ends of the secondary windings. i.e.
 Connect 2.1. of Tr.1 with 2.2 of tr.3 and mark it as 2 U
 Connect 2.2. of Tr.1 with 2.1 of tr.2 and mark it as 2 V
 Connect 2.2. of Tr.2 with 2.1 of tr.3 and mark it as 2 W
- 3 Connect 1U, 1V, 1W to ICTP switch S1.
- 4 Connect a voltmeter 0-500V across 1U and 1V.
- 5 Connect a voltmeter 0-300V across 2U and 2V.
- 6 Close the switch S1 and Note down the primary line voltage and secondary line voltage in tabular column under Delta-Delta connection.

- 7 Calculate the ratio of secondary line voltage and primary line voltage. Compare the values with Theoretical values.

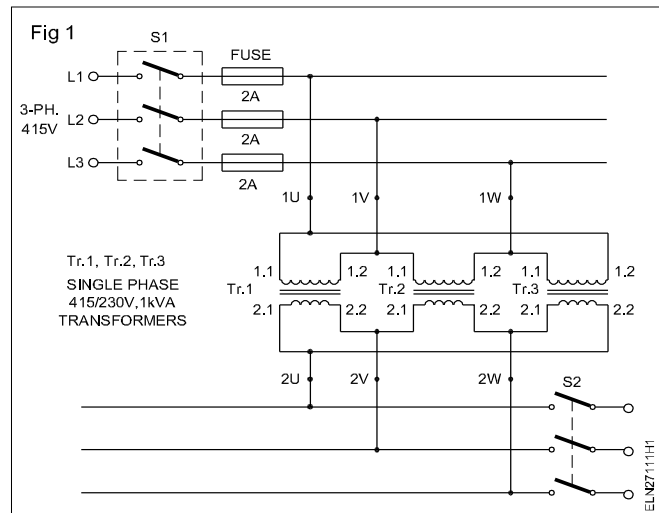

TASK 2 : To connect in star-star connection

- 1 Connect any three similar ends of primary winding together. Say connect 1.2 of Tr.1, 1.2 of Tr.2, 1.2 of Tr.3 together and mark the junction as 1N. (Fig 2)
- 2 Mark 1.1 of Tr.1 as 1U, 1.1 of Tr.2 as 1V and 1.1 of Tr.3 as 1W.
- 3 Connect any three similar ends of secondary winding together. Say connect 2.2 of Tr.1, 2.2 of Tr. 2, 2.2 of Tr.3 together and mark the junction as 2N as shown in circuit 2.
- 4 Mark 2.1 of Tr.1 as 2U, 2.1 of Tr.2 as 2V and 2.1 of Tr.3 as 2W.
- 5 Repeat the steps 3,4,5,6,7 of Task 1.

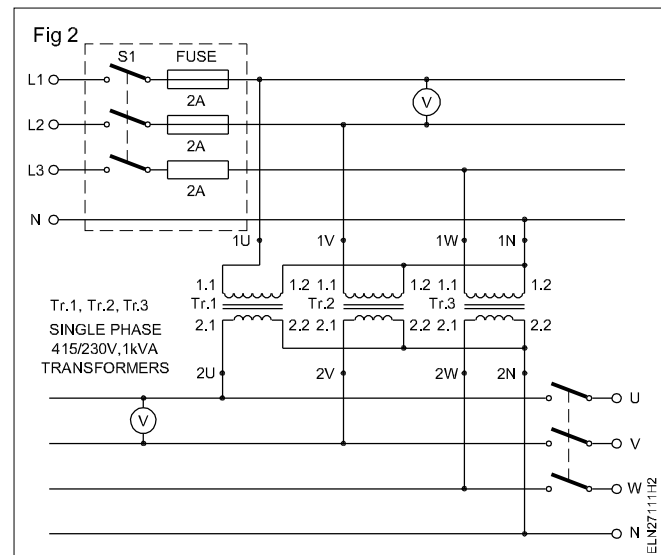

TASK 3 : To connect in star-delta connection

- 1 Connect three similar terminals of the primary windings together. Say connect 1.2 of Tr.1, 1.2 of Tr.2, 1.2 of Tr.3 and mark the junction as 1N. As shown in Fig 3.
- 2 Mark 1.1 of Tr.1 as 1U, 1.1 of Tr.2 as 1V and 1.1 of Tr.3 as 1W.
- 3 Connect the dissimilar terminals of the secondary windings.
Connect 2.1. of Tr.1 with 2.2 of tr.3 and mark it as 2 U
Connect 2.2. of Tr.1 with 2.1 of tr.2 and mark it as 2 V
Connect 2.2. of Tr.2 with 2.1 of tr.3 and mark it as 2 W
- 4 Repeat steps 3, 4, 5, 6, 7 of Task 1.

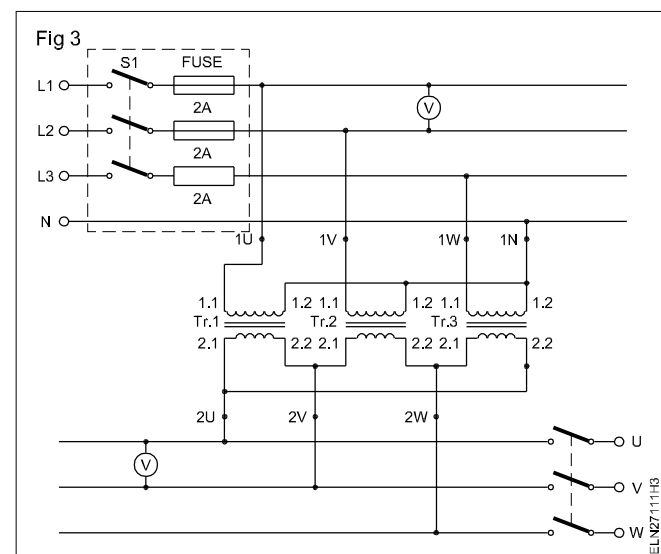

TASK 4 : To connect in delta-star connection

- 1 Connect the dissimilar terminals of the primary windings as follows. (Fig 4)
 Connect 1.1. of Tr.1 with 1.2 of tr.3 and mark it as 1 U
 Connect 1.2. of Tr.1 with 1.1 of tr.2 and mark it as 1 V
 Connect 1.2. of Tr.2 with 1.1 of tr.3 and mark it as 1 W.
- 2 Connect the three similar terminals of secondary windings together. Say connect 2.2 of Tr.1, 2.2 of Tr.2, 2.2 of Tr.3 and mark the junction as 2N as shown in Fig 4.
- 3 Mark 2.1 of Tr.1 as 2U, 2.1 of Tr.2 as 2V and 2.1 of Tr.3 as 2W.
- 4 Repeat steps 3,4,5,6,7 of Task 1.

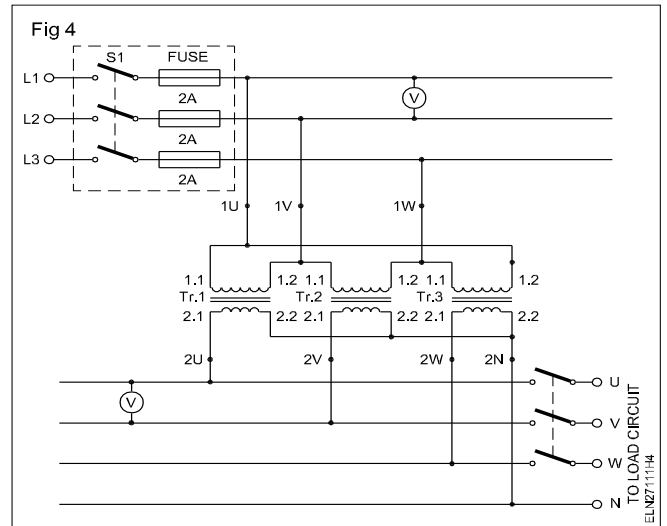

Voltage ratio of each transformer K =.....

Tabular Column

Type of Connection	Primary Line Voltage	Secondary Line Voltage	Line Voltage Ration (Theoretical)	Line Voltage Ration (Practical)
			= $\frac{\text{Secondary Line Voltage}}{\text{Primary Line Voltage}}$	
Delta - Delta				
Star - Star				
Star - Star				
Delta - Star				

If a 3 single phase transformer is available with six secondary terminals brought out then follow the same procedure as given in above tasks with the following given terminal markings.

	Transformer Windings 1		Transformer Windings 2		Transformer Windings 3	
	Starting	Ending	Starting	Ending	Starting	Ending
Primary (HT)	1.1U	1.2U	1.1V	1.2V	1.1W	1.2W
Secondary (LT)	2.1U	2.2U	2.1V	2.2V	2.1W	2.2W

Test and replace transformer oil

Objectives: At the end of this exercise you shall be able to

- **conduct field test on the transformer oil**
- **conduct crackle test on transformer oil**
- **connect dielectric test on the transformer oil using standard test set.**

Requirements	
<p>Tools/Instruments</p> <ul style="list-style-type: none"> • Glass tumbler - 1 No. • Pipette - 1 No. • 200mm dia. metal tube with one side closing - 1 No. • Insulated piler - 1 No. • 100 mm connector screw driver - 1 No. • Double end electrician knife - 1 No. 	<p>Equipments/Machines</p> <ul style="list-style-type: none"> • Standard transformer oil test kit with it's accesories - 1 No. • Electric heater 1000 watts/250V - 1 No. <p>Materials</p> <ul style="list-style-type: none"> • Samples transformer oil (different samples) - as reqd. • Distilled water - as reqd.

PROCEDURE

TASK 1 : To conduct field test

- 1 Collect a glass tumbler, pipette, oil sample and distilled water on the work bench.
- 2 Fill the glass tumbler with the distilled water to 3/4th level.
- 3 Take a sample drop of transformer oil through a pipette and drop a single drop on the distilled water.
- 4 Observe, the field of the oil surface and record the field diameter and shape.

- a The shape of the oil drop
- b The dia for the field
- c Condition of oil good/bad.

If the shape of drops retained, the oil is good. If the shape is flattened and the drop occupies the area of diameter less than 18mm, the oil may be used. If it is more, it is not suitable and it has to be reconditioned.

TASK 2 : To conduct Crackle test

- 1 Collect, steel tube, heater and a sample of transformer oil.
- 2 Heat the close end of steel tube.
- 3 Pour the oil sample into the tube.
- 4 Take the open end of the tube to the ear and hear the sound.

- 5 Record the sound heard.
 - a Sound heard
 - b The condition of the oil is ..

If the oil contains moisture, a sharp crackle sound will be heard. Dry oil will only sizzle.

TASK 3 : To conduct dielectric test with oil testing kit

- 1 Examine the oil testing set and read the instructions given by the manufacturer. (Fig 1)
- 2 Take a sample of the transformer oil in a clean, transparent and dry glass bottle. If there is a drain valve take the sample from the drain valve.

If it is not possible to take the sample from the drain valve then the sample may be drawn by syphoning off from the conservator tank.

- 3 Take atleast three samples in three bottles from the transformer to conduct atleast three tests.
- 4 Clean the standard test cup by washing it with clean oil and adjust the gap of the electrodes in such a way that it should be of 4 mm.

Measure the gap by the calibrated gauge, which is usually supplied with the equipment.

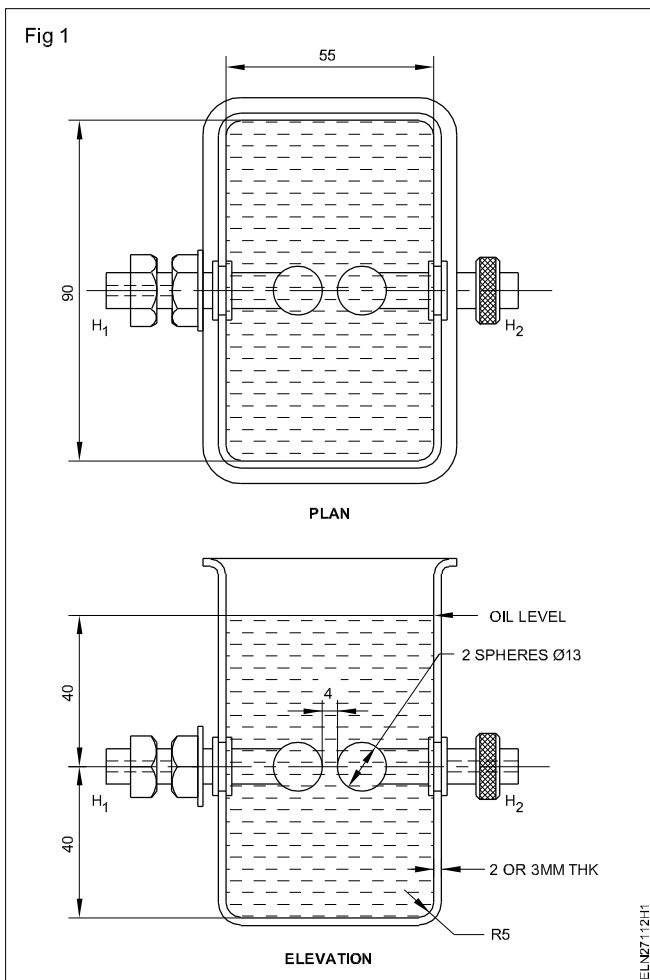

- 5 Fill the cup with a sample of oil to be tested 1 cm above the electrodes or the marked level on the cup.
- 6 Close the cup with a clean cover and allow 5 minutes for the oil to settle so that all air bubbles may disappear.
- 7 Make sure that the test area is clear of all the other persons.
- 8 Set voltage regulation at zero position.
- 9 Switch 'ON' the supply.
- 10 Raise the voltage gradually from zero so that the full voltage is reached within 20 to 30 seconds.

It is quite possible that a spark may occur at a very early stage i.e even 20 kV due to some extraneous matter like microscopic strands of cotton, dust etc. which have a tendency to get aligned along the strong electrostatic field in the spark gap. It may burn out and may not affect the test.

- 11 Raise the voltage until the final breakdown of the oil. The circuit breaker will get tripped. Simultaneously watch the voltmeter and note the readings of the breakdown voltage. (Fig 2)

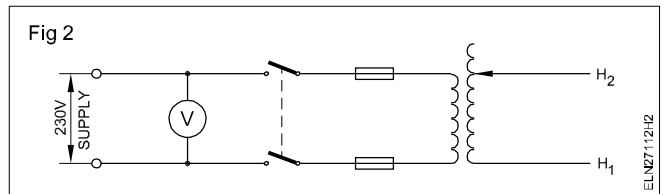

After sparking the oil near the electrode will turn black in colour.

- 12 Repeat the steps 5 to 11 with oil in the second sample.

Note that the breakdown voltage of the first and second samples should be approximately equal.

- 13 Prepare the test for the third sample.
- 14 Conduct the test by increasing the test voltage up 40 KV.
- 15 Apply the test voltage for about one minute and observe that there is no sparking.

Note that good oil should withstand 40 kV for one minute.

Conclusion

Since the water is heavier than oil, it settles down at the bottom of the tank.

- 16 If the tested oil is in good condition, fill this oil in the transformer tank up to the oil level marked on the body of the transformer tank.

Practice on winding of small transformer

Objectives: At the end of this exercise you shall be able to

- **dismantle the transformer cores**
- **measure and determine the size of winding wire for primary and secondary winding**
- **take the dimensions of a bobbin and prepare the bobbin from suitable materials**
- **wind the primary and secondary windings layer by layer**
- **stack the cores and fasten them**
- **terminate the winding end in a terminal board**
- **test the transformer for insulation, transformation ratio and performance**
- **design a transformer when power and voltage ratings are known.**

Requirements			
Tools/Instruments		Materials	
• Scissors 150 mm	- 1 No.	• Super-enamelled copper wires	- as reqd.
• Steel rule 300 mm	- 1 No.	• Empire sleeves 1 mm, 2mm	- 1 m each
• Firmer chisel 20 mm	- 1 No.	• Air-dry varnish	- 100 ml.
• Hammer ball pein 0.5 kg	- 1 No.	• Resin-core solder 16 SWG	- 10 G
• Iron soldering 25 W, 240V	- 1 No.	• Soldering paste	- 5 g
• DE spanner 6 mm to 25 mm	- 1 No.	• Smooth emery paper	- 1 piece
• Mallet hardwood 0.5 kg	- 1 No.	• Fabric based fibre sheet and 6 mm thick	- 3 mm
• Nylon mallet 5 cm dia.	- 1 No.	• Cotton cloth for cleaning	- 500sq.cm
• D.B. Knife 100 mm	- 1 No.	• Insulation papers	- as reqd.

PROCEDURE

TASK 1 : Dismantling the transformer for rewinding

- | | |
|---|--|
| <ol style="list-style-type: none"> 1 Note down the name plate details in Table 1. 2 Draw the end connection terminal marking of the transformer in your record. 3 De-solder the leads and remove the terminal strips if they are attached to the core. 4 Loosen the nuts of the core assembly and remove the screws if any. | <ol style="list-style-type: none"> 5 Remove the clamps attached to the core. 6 Gently tap the transformer core with a nylon mallet so that the core gets loosened. 7 Remove the stampings starting from the centre of the core using Hylam/fibre knife. |
|---|--|

In the case of hard stacked stamping, occasionally use a thinner to loosen the stamping.

Table 1

Transformer rating plate

No of Phase	Sl.No.....
V.A rating	Frequency
Primary voltage.....volt	Secondary voltage.....volt
Primary current.....amp	Secondary current.....amp
Manufacturer	

If a metal knife is used to remove the tight and sticky stampings, care should be taken not to damage the stampings. While stripping the core see that the stampings are taken out straight without bends.

8 Remove all the stampings and record the following in Table 2.

Table 2
Core details

Type of core
No. of stampings of shape..... No.....
No. of . stamping of shape..... No.....

9 Wipe the bobbin and winding with a cloth.

10 Record the dimensions of the coil in Table 3 with and without insulation and prepare a template to check the winding's height and length.

Table 3
Size of the coil

Description	With insulation	Without insulation	Remarks
Coil heightcm cm.	
Coil heightcm. cm.	

- Strip off the winding carefully. During the stripping process record all the particulars in Table 4.
- Draw the schematic diagram of the primary and secondary sides of the transformer from the above findings in your record.
- Clean the bobbin, write down the bobbin particulars in Table 5 for your guidance.

The same bobbin can be used if it is not damaged.

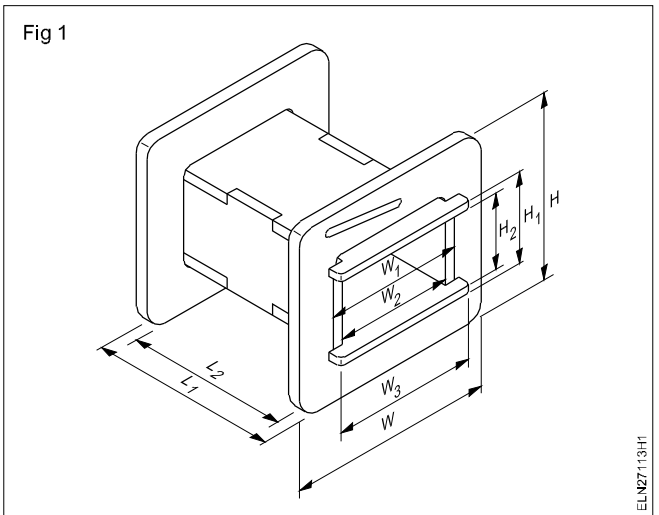

Table 4

Winding details

Total No. of winding/turns			
No. of layers			
No. of turns/layer Min			
Layer insulation TypeThicknessmm.			
	With Insulation	Without Insulation	Wt.of thecoil
Primary winding			
1 st Tapping, No. of turnsdiameter of wiremm.mmg
2 nd Tapping, No. of turns ...diameter of wiremm.mmg
3 rd Tapping, No. of turns ... diameter of wiremm.mmg
Secondary winding			
Winding 1, No. of turnsdiameter of wiremm.mmg
Winding 2, No. of turns ...diameter of wiremm.mmg
Winding 3, No. of turns ... diameter of wiremm.mmg
Coil insulation - typethicknessmm.			
Connecting leadsize			

Table 5
Bobbin details

- 1 Type of bobbinInjection moulded/Built up
- 2 Bobbin materialThicknessmm.
- 3 Length of the bobbin L.....mm, L_1mm, L_2mm.
- 4 Width of the bobbin W.....mm, W_1mm, W_2mm, W_3mm.
- 5 Height of the bobbin Hmm, H_1mm, H_2 mm

TASK 2 : Preparation of bobbin

- 1 Referring to the data taken in Table 5 and as per Fig 1, prepare the bobbin parts from a hylam/fibre sheet of the same thickness.

Bobbin parts of standard sizes are also available in the market which can be assembled to form the bobbin.

- 2 Assemble the parts of the bobbin as shown in Fig 2 which is given for your guidance.
- 3 Check the size of the assembled bobbin and verify it with the data taken and recorded in Table 5.

In the case of an injection moulded bobbin it can be purchased from the market assuming it is of standard size.

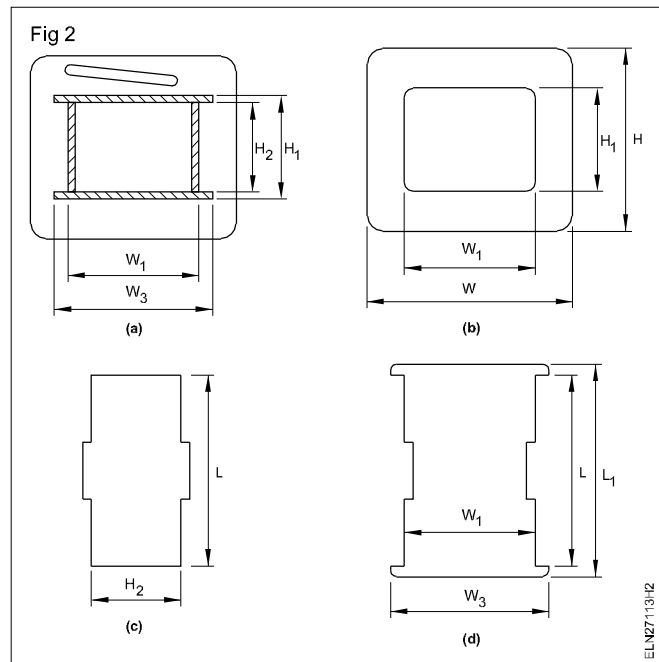

TASK 3 : Rewinding of transformer

- 1 Prepare/select a suitable mandrel for the prepared bobbin as shown in Fig 3 or prepare a wooden block as shown in Fig 4 depending upon the design of the winding machines.

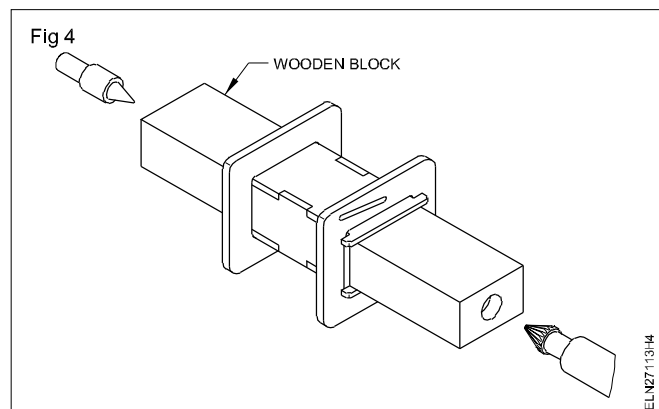
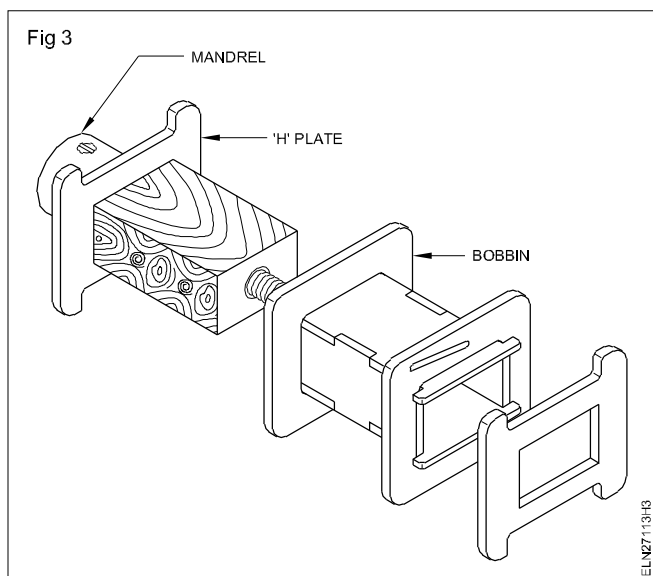

- 2 Clamp the mandrel/wooden block in the winding machine.

See to it that while clamping the mandrel/wooden block, under no circumstances the work becomes loose during winding.

- 3 Fit the bobbin tightly to the mandrel of the winding machine with the help of fasteners as the bobbin must turn along with the mandrel without play. (Fig 5).

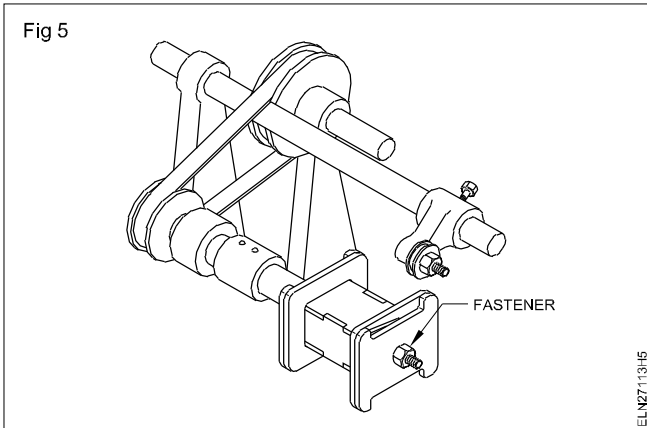

- Adjust the feed of the winding machine to suit the selected winding wire size by friction drive or by changing the gear as shown in number 1 of Fig 6 and 7.

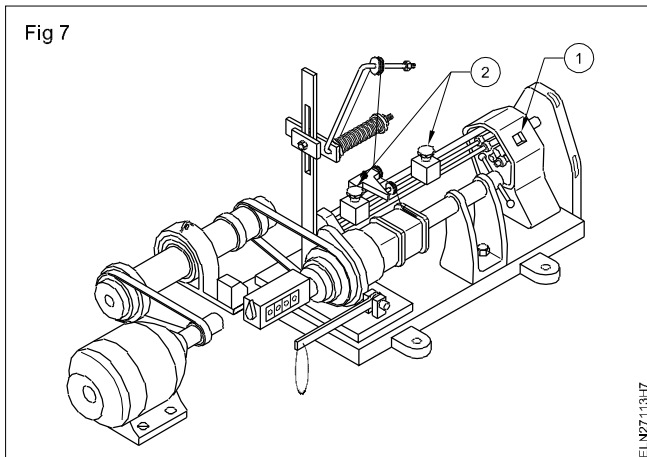
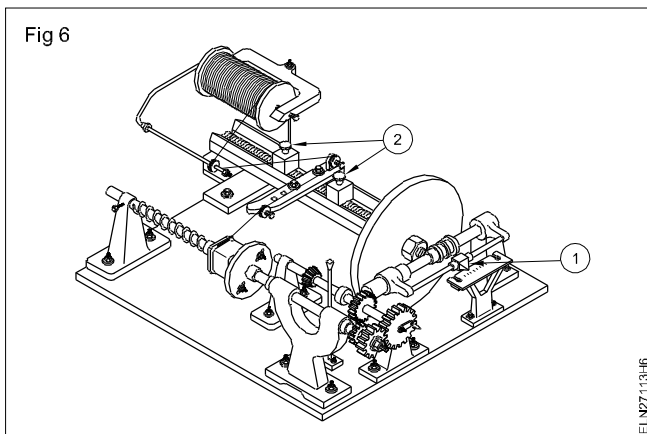

- Adjust the transverse feed of the winding machine guides such that the length of the inner side of the bobbin so as to maintain the length of the coil as in the original. Refer to number 2 of Figs 6 and 7. You may need several trials before final setting.
- Place one layer of paper or cloth as core insulation on the bobbin smoothly without crease.
- Solder a connecting lead and sleeve the same with the beginning end of the selected winding. Place the lead wire at one end of the bobbin and take it through the bobbin flange outlet and tie with a knot to avoid slipping as shown in Fig 8.

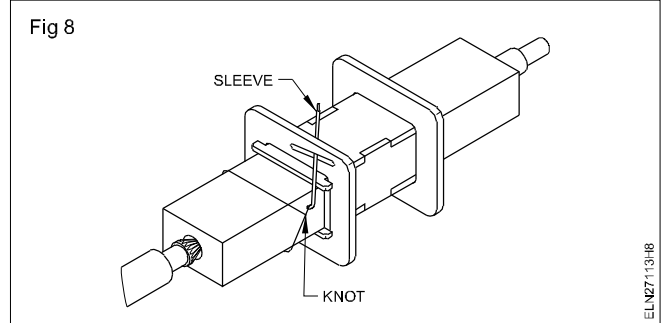

If the winding wire thickness is sufficiently large, soldering of connecting lead wire is not necessary.

- Start the winding and complete atleast one layer to check whether the coil length is well within the bobbin as in the original. If not, readjust the transverse feed.

Adjacent turns of the winding wire should not overlap or have a gap in between them. if incorrect, readjust the feed.

- Start and continue the winding layer by layer providing the necessary in-between insulation and specified number of turns in each layer as per data taken in Table 4.
- After the designated number of turns are wound, solder the end lead and take it out through the bobbin flange outlet.

If a coil has a number of taps of winding, never cut the wire. Instead fold the length into a long loop and carry the wire to continue the winding. The looped wire can then be bared and connected outside the coil.

- After inspecting the primary winding, wrap the winding as shown in Fig. 9 with sufficient insulation according to the data taken in Table 4.

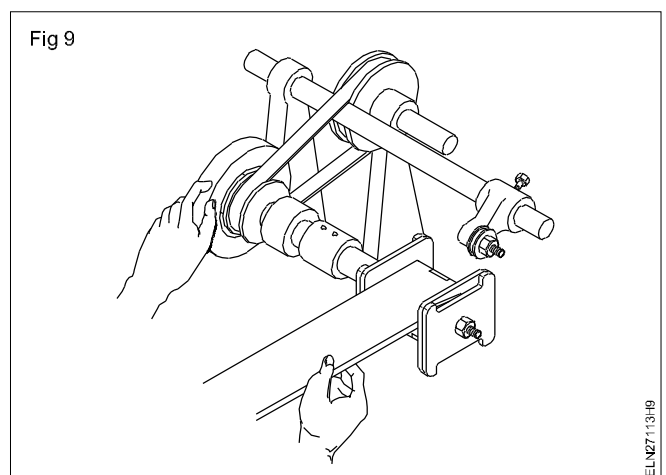

- Select a suitable secondary winding wire as shown in the data taken in Table 4 and proceed as in steps 4 to 7.

The transformer may be provided with one or more secondary windings or tapped windings. In such a case follow the data recorded and also refer to the connection diagram shown in step 12, Task 1.

13 At the end of the winding, wrap and bind the insulation on the winding tightly.

Bindings must cover the winding fully and must be free of crease and must not project beyond the coil disc (flange).

14 Inspect the coil for proper termination of lead and check the size by using a template and data taken in Table 3.

15 Test the windings for continuity and short circuit.

If winding data is not available or a new transformer has to be designed and wound, follow the instructions contained in the Related Theory, Exercise No: 1202.

TASK 4 : Stacking of transformer cores (E & I)

- 1 Insert an 'E' lamination into the bobbin from both sides as shown in Fig 10a.
- 2 Place the right hand side (R.H.S.) laminations below the one inserted from the left hand side (L.H.S.).
- 3 Place an 'I' lamination to the free end of the L.H.S. 'E' piece as in Fig 10b.

5 Place an 'I' shaped lamination in position.

Ensure that it lies flat on the first "E" lamination.

6 Likewise insert the laminations alternately without any gap as shown in Fig 11.

Fig 10(a)

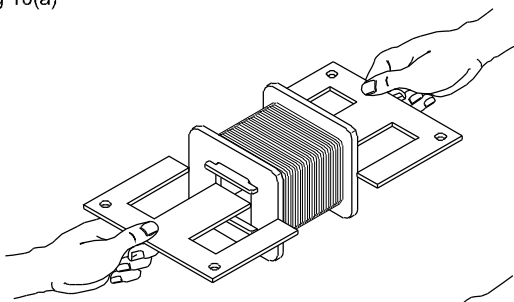
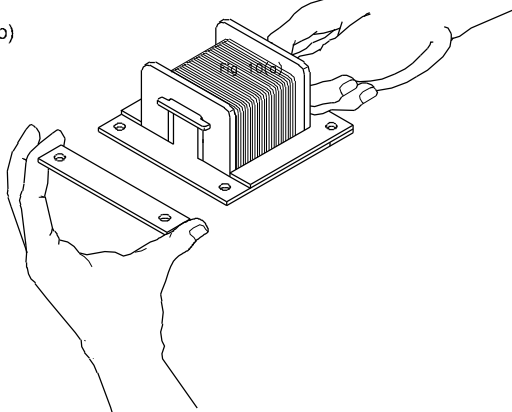

Fig 10(b)



ELN27113HA

Ensure that the slot in the 'I' is above the corresponding slot in the R.H.S. 'E' lamination.

The laminated assembly should be flush and lying flat.

4 Insert the second 'E' shaped laminations from the opposite side.

Ensure that it fits snugly against the bobbin.

Fig 11

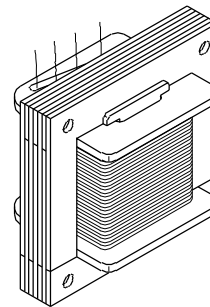

ELN27113HB

Ensure that when all of the specified quantity of laminations are inserted, the assembly has the right dimension, from loose laminations and correct interpolated laminations.

7 Fit both the top and bottom clamp plates on the assembly as in the original. (Figs 12a and 12b)

Fig 12(a)

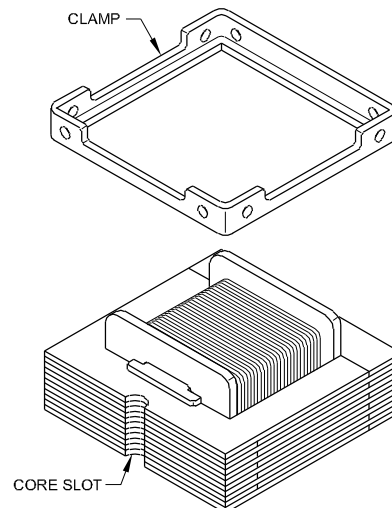

CORE SLOT

ELN27113HC

Pay particular attention to align the core slots in the laminations.

Ensure that the fixing bolts can be easily inserted.

- 8 Push the fixing bolts through the clamp plates.
- 9 Use the specified fasteners and tighten the assembly.
- 10 Varnish the transformer by dipping in an air-dry varnish and drain it.
- 11 Fit the specified insulating sleeves over the lead-out wires.
- 12 Obtain the specified terminal board and pass each lead-out through the specified hole.

Ensure that all the sleeved leads are correctly positioned.

Check that all the sleeved leads terminate at each hole i.e. no bare leads should be visible in the terminal board.

- 13 Place the terminal board in position as shown in Fig 13.

- 14 Secure the terminal board with the specified studs.
- 15 Check that no leads have been trapped between the terminal board and the core.
- 16 Make the specified mechanical joint between each lead-out wire and its soldering tag.
- 17 Solder each joint and cut off the surplus wire ends as seen in Fig 13.

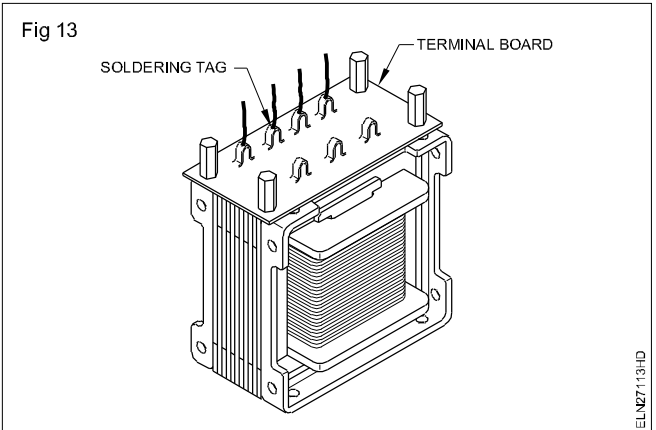

TASK 5 : Testing of transformer after winding

- 1 Test the primary and secondary windings for continuity with a megger.
- 2 Measure and record the primary and secondary winding resistance in Table 6.

Table 6

Transformer winding resistance

Primary	resistance ohm
Secondary 1	resistance ohm
Secondary 2	resistance ohm
Secondary 3	resistance ohm

- 3 Measure and record the insulation resistance, between windings and frame in Table 7.

Table 7

Insulation resistance between

Primary & secondary windings megohm
Secondary windings (in case of separate windings) megohm
Windings and frame megohm

- 4 Connect the primary winding of the transformer with the rated voltage. Keeping the secondary open, test the primary and the secondary voltage. Record the finding in Table 8.

Table 8

No-load measurement

Primary voltage volt
Secondary voltage	
1 volt
2 volt
3 volt

- 5 Observe for vibration sound of the core. If it is abnormal, tighten the stampings, also check for tightness of the coil.
- 6 Connect the transformer with suitable load so that full load current passes through the secondary, and record the voltage and current at load in Table 9.

Table 9

Load measurement

Primary voltage volt
Primary current amp
Secondary voltage volt
Primary current amp

- 7 Keep the transformer on full load for eight hours continuously. Observe the change in temperature of the winding and core by touching. If the temperature rise is within the class of insulation, the transformer is O.K.

TASK 6 : **Testing of transformer after winding**

- 1 Collect the following data from the customer.
 - output, power and frequency
 - input and output volt
 - duty rating, (intermittent or continuous)
- 2 Follow the procedure outlined in Related Theory for Exercise No.2.7.113 determine the dimensions of the transformer, bobbin, number of turns in primary and secondary and the size of winding wire for primary and secondary.
- 3 Follow the procedure stated in this job sheet except dismantling of the transformer core and complete the winding.

Practice of general maintenance of transformer

Objectives: At the end of this exercise you shall be able to

- carry out hourly maintenance of transformer
- carry out daily maintenance of transformer.

Requirements	
Tools/Instruments <ul style="list-style-type: none"> • Electrician tool kit 	Materials <ul style="list-style-type: none"> • Items required for reactivating silica gel. • Spare relief diaphragm.

Note: The instructor may take the trainees to the transformer yard and demonstrate the maintenance procedures.

PROCEDURE

TASK 1 : To carry hourly maintenance

- | | |
|--|--|
| <ol style="list-style-type: none"> 1 Note down the secondary load current of the transformer read by the ammeter provided. 2 Check this value with the rated value as per name plate details. 3 If the load current is more than the rated value then reduce the load on transformer by the following sequence. <ol style="list-style-type: none"> a Trip off the circuit breaker | <ol style="list-style-type: none"> b Switch off the load feeders which are not very essential c Again charge and switch on the circuit breaker. 4 Record the values of primary line voltage and line current and secondary line voltage and line current and PF in Table 1. 5 Note down the oil temperature which is indicated by thermostat dial or thermometer in Table 1. |
|--|--|

Table1

Maintenance chart for hourly maintenance of 3 ϕ transformer

Sl. No.	Date & Time	Primary Line Voltage		Secondary Line Voltage		Secondary Current		Power Factor	Oil Temp	Remarks
		Phases	Voltage (V)	Phases	Voltage (V)	Phases	Current in Amps			
1		1U - 1V		2U - 2V		2U				
2		1V - 1W		2V - 2W		2V				
3		1W - 1U		2W - 2U		2W				



TASK 2 : To carry out daily maintenance of transformer

- | | |
|--|---|
| <ol style="list-style-type: none"> 1 Inspect the dehydrating breather, by following sequence. <ol style="list-style-type: none"> a Check whether the air passages are clear, if not clean it b Check the colour of the active agent i.e. silicagel | <ol style="list-style-type: none"> c If the silicagel is pink in colour, reactivate it in following sequence. 2 Collect the silica gel crystals in a shallow tray and bake them at 200°C. 3 When the crystals become blue in colour, fill the breather with reactivated blue crystals. |
|--|---|

- 4 Inspect the oil level in the transformer.
- 5 Observe the conservator sight glass and check the oil level of the transformer.
- 6 If the oil level is low, top up the level through drain valve by filling clean transformer oil.
- 7 If the oil level drops appreciably over a short period, then check the tank for any oil leakage.
- 8 If there is a leak in the transformer tank, take suitable actions to prevent leakage by consulting the instructor.
- 9 Inspect the relief diaphragm.
- 10 Observe the explosion vent of the transformer and check the condition of relief diaphragm and record the observations in Table 2.
- 11 If it is cracked or broken replace it after isolating the primary supply to the transformer.

Table 2

Maintenance chart for daily maintenance of 3 ϕ oil cooled transformer

Date	Time	Oil level	Colour of Silicagel	Condition of relief diaphragm	Remarks action taken

Project Work

Objectives: The Trainees/Participants shall be able to

- select a project work of their choice
 - prepare the list of materials required and collect them
 - list out the tools required
 - prepare a brief note on the project
 - complete the project and submit the project report with all the details.
-

Note: Instructor has to explain in detail regarding the project works to be carried out in the section. The trainees may be divided in groups according to the strength available in section and give all details how to prepare and finish the work with complete workmanship and accuracy.

- Step to start and follow the project work
- Motivate the group by emphasising the technical work involved and its future influences.
- Divide the work equally and make sure in yoke participating with full interest.
- Start the project work, test it stage by stage and complete it.
- Test the completed project job for its functionality and its utility.
- Prepare a project report containing its technical parameters, specification, material requirement and its cost, operational procedure, maintenance, utility and marketing etc.
- Indicate the scope of future expansion, easy conversion to other project for advanced version in the report.

- Get it checked with your instructor.
- The project should complete with all operational instructions and carry necessary procedure with switches, controls, labels, symbols etc.
- Safety devices has to be placed according to the project and its functions.
- Maintenance and repair instructions should be indicated clearly.

Note: Instructor has to evaluate the project work with all records and reports. Marks to be awarded for the project working, accuracy, workmanship, safety features and its work performance related to the viva questions.

Project work

- 1 Overload protection of electrical equipment.
- 2 Automatic control of street light/night lamp.
- 3 Fuse and power failure indicator using relays.
- 4 Door alarm/indicator.
- 5 Decorative light with electrical flasher.