

ELECTRICIAN

NSQF (LEVEL - 5)

2nd Year (Volume II of II)

TRADE PRACTICAL

SECTOR: Electrical



Directorate General of Training

**DIRECTORATE GENERAL OF TRAINING
MINISTRY OF SKILL DEVELOPMENT & ENTREPRENEURSHIP
GOVERNMENT OF INDIA**



**NATIONAL INSTRUCTIONAL
MEDIA INSTITUTE, CHENNAI**

Post Box No. 3142, CTI Campus, Guindy, Chennai - 600 032

Sector : Electrical

Duration : 2 - Years

Trade : Electrician 4th Semester - Trade Practical - NSQF (LEVEL - 5)

Copyright © 2018 National Instructional Media Institute, Chennai

First Edition : November 2018

Copies : 1,000

Rs.165/-

All rights reserved.

No part of this publication can be reproduced or transmitted in any form or by any means, electronic or mechanical, including photocopy, recording or any information storage and retrieval system, without permission in writing from the National Instructional Media Institute, Chennai.

Published by:

NATIONAL INSTRUCTIONAL MEDIA INSTITUTE
P. B. No.3142, CTI Campus, Guindy Industrial Estate,
Guindy, Chennai - 600 032.
Phone : 044 - 2250 0248, 2250 0657, 2250 2421
Fax : 91 - 44 - 2250 0791
email : nimi_bsnl@dataone.in
chennai-nic.in
Website: www.nimi.gov.in

FOREWORD

The Government of India has set an ambitious target of imparting skills to 30 crores people, one out of every four Indians, by 2020 to help them secure jobs as part of the National Skills Development Policy. Industrial Training Institutes (ITIs) play a vital role in this process especially in terms of providing skilled manpower. Keeping this in mind, and for providing the current industry relevant skill training to Trainees, ITI syllabus has been recently updated with the help of Mentor Councils comprising of various stakeholder's viz. Industries, Entrepreneurs, Academicians and representatives from ITIs.

National Instructional Media Institute (NIMI), Chennai has come up with instructional material to suit the revised curriculum for **Electrician 4th Semester Trade Practical NSQF (LEVEL - 5)** in **Electrical** sector under Semester Pattern required for ITIs and related institutions imparting skill development. The NSQF (LEVEL- 5) will help the trainees to get an international equivalency standard where their skill proficiency and competency will be duly recognized across the globe and this will also increase the scope of recognition of prior learning. NSQF (LEVEL- 5) trainees will also get the opportunities to promote life long learning and skill development. I have no doubt that with NSQF (LEVEL- 5) the trainers and trainees of ITIs, and all stakeholders will derive maximum benefits from these IMPs and that NIMI's effort will go a long way in improving the quality of Vocational training in the country.

The Executive Director, Staffs of NIMI and members of Media Development Committee deserve appreciation for their contribution in bringing out this publication.

Jai Hind

RAJESH AGGARWAL

Director General / Addl. Secretary,
Ministry of Skill Development & Entrepreneurship,
Government of India.

New Delhi - 110 001

PREFACE

The National Instructional Media Institute (NIMI) was established in 1986 at Chennai by then Directorate General of Employment and Training (D.G.E & T), Ministry of Labour and Employment, (now under Ministry of Skill Development and Entrepreneurship) Government of India, with technical assistance from the Govt. of the Federal Republic of Germany. The prime objective of this institute is to develop and provide instructional materials for various trades as per the prescribed syllabi (NSQF) under the Craftsman and Apprenticeship Training Schemes.

The instructional materials are created keeping in mind, the main objective of Vocational Training under NCVT/NAC in India, which is to help an individual to master skills to do a job. The instructional materials are generated in the form of Instructional Media Packages (IMPs). An IMP consists of Theory book, Practical book, Test and Assignment book, Instructor Guide, Audio Visual Aid (Wall charts and Transparencies) and other support materials.

The trade practical book consists of series of exercises to be completed by the trainees in the workshop. These exercises are designed to ensure that all the skills in the prescribed syllabus are covered. The trade theory book provides related theoretical knowledge required to enable the trainee to do a job. The test and assignments will enable the instructor to give assignments for the evaluation of the performance of a trainee. The wall charts and transparencies are unique, as they not only help the instructor to effectively present a topic but also help him to assess the trainee's understanding. The instructor guide enables the instructor to plan his schedule of instruction, plan the raw material requirements, day to day lessons and demonstrations.

IMPs also deals with the complex skills required to be developed for effective team work. Necessary care has also been taken to include important skill areas of allied trades as prescribed in the syllabus.

The availability of a complete Instructional Media Package in an institute helps both the trainer and management to impart effective training.

The IMPs are the outcome of collective efforts of the staff members of NIMI and the members of the Media Development Committees specially drawn from Public and Private sector industries, various training institutes under the Directorate General of Training (DGT), Government and Private ITIs.

NIMI would like to take this opportunity to convey sincere thanks to the Directors of Employment & Training of various State Governments, Training Departments of Industries both in the Public and Private sectors, Officers of DGT and DGT field institutes, proof readers, individual media developers and coordinators, but for whose active support NIMI would not have been able to bring out this materials.

Chennai - 600 032

**R. P. DHINGRA
EXECUTIVE DIRECTOR**

ACKNOWLEDGEMENT

National Instructional Media Institute (NIMI) sincerely acknowledges with thanks for the co-operation and contribution extended by the following Media Developers and their sponsoring organisations to bring out this Instructional Material (**Trade Practical**) for the trade of **Electrician NSQF (LEVEL - 5)** under **Electrical Sector** for ITIs.

MEDIA DEVELOPMENT COMMITTEE MEMBERS

- | | | |
|-----------------------|---|---|
| Shri. T. Muthu | - | Principal (Retd.),
Govt. ITI (W),
Madurai, Tamil Nadu |
| Shri. C.C. Jose | - | Training Officer (Retd.),
ATI, Guindy,
Chennai |
| Shri. K. Lakshmanan | - | Assistant Training Officer (Retd.),
Govt. ITI, Ambattur
Chennai |
| Shri. N. Senthilkumar | - | Vocational Instructor,
ATI, Guindy
Chennai |

NIMI CO-ORDINATORS

- | | | |
|-------------------------|---|---|
| Shri. K. Srinivasa Rao | - | Joint Director
NIMI, Chennai - 32. |
| Shri. Subhankar Bhowmik | - | Assistant Manager,
NIMI, Chennai - 32. |

NIMI records its appreciation for the Data Entry, CAD, DTP operators for their excellent and devoted services in the process of development of this Instructional Material.

NIMI also acknowledges with thanks the invaluable efforts rendered by all other NIMI staff who have contributed towards the development of this Instructional Material.

NIMI is also grateful to everyone who has directly or indirectly helped in developing this Instructional Material.

INTRODUCTION

This manual for trade practical is intended for use in the ITI workshop. It consists of a series of practical exercises that are to be completed by the trainees during the first semester of course is the **Electrician trade under Electrical Sector. It is National Skills Qualifications Framework NSQF (LEVEL - 5)**, supplemented and supported by instructions/information to assist the trainees in performing the exercise. The exercises are designed to ensure that all the skills prescribed in the syllabus are covered including the allied trades. The syllabus for the 4th Semester **Electrician** Trade under **Electrical Sector** Trade Practical is divided into Seven Modules. The allocation of time for the various modules is given below:

Module 1 - Electronic Practice	15 Exercises	175 Hrs
Module 2 - Control Panel Wiring	5 Exercises	100 Hrs
Module 3 - AC/DC Motor Drives	3 Exercises	50 Hrs
Module 4 - Inverter and UPS	6 Exercises	75 Hrs
Module 5 - Power Generation and Substation	7 Exercises	50 Hrs
Module 6 - Transmission and Distribution	7 Exercises	50 Hrs
Module 7 - Circuit Breakers and Relays	5 Exercises	25 Hrs
Total	48 Exercises	525 Hrs

The syllabus and the content in the modules are interlinked. As the number of workstations available in the electrical section is limited by the machinery and equipment, it is necessary to interpolate the exercises in the modules to form a proper teaching and learning sequence. The sequence of instruction is given in the schedule of instruction which is incorporated in the Instructor's Guide. With 25 practical hours a week of 5 working days 100 hours of practical per month is available.

Contents of Trade Practical

The procedure for working through the 48 exercises for the 4th semester with the specific objectives as the learning out comes at the end of each exercise is given in this book.

The skill objectives tools/instruments, equipment/machines and materials required to perform the exercise are given in the beginning of each exercise. Skill training in the shop floor is planned through a series of practical exercises/experiments to support the related theory to make the trainees get hands on training in the Electrician trade along with the relevant cognitive skills appropriate for the level. A minimum number of projects have been included to make the training more effective and develop attitude to work in a team. Pictorial, schematic, wiring and circuit diagrams have been included in the exercises, wherever necessary, to assist the trainees broaden their views. The symbols used in the diagrams comply with the Bureau of Indian Standards (BIS) specifications.

Illustrations in this manual, help trainees visual perspective of the ideas and concepts. The procedures to be followed for completing the exercises are also given. Different forms of intermediate test questions have been included in the exercises, to enhance the trainee to trainee and trainee to instructor interactions.

Skill Information

Skill areas which are repetitive in nature are given as separate skill information sheets. Skills which are to be developed in specific areas are included in the exercises itself. Some sub exercises are developed to fulfill the sequence of exercises in keeping with the syllabus.

This manual on trade practical forms part of the Written Instructional Material (WIM), which includes manual on trade theory and assignment/test.

CONTENTS

Exercise No.	Title of the Exercise	Page No.
Module 1 : Electronic Practice		
4.1.160	Determine the value of resistance by colour code and identify the types	1
4.1.161	Test active and passive electronic components and its applications	4
4.1.162	Determine the V-I characteristics of semi conductor diode	9
4.1.163	Construct half-wave, full wave and bridge rectifiers using semi conductor diode	12
4.1.164	Check transistors for their functioning by identifying its type and terminals	16
4.1.165	Bias the transistor and determine its characteristics	19
4.1.166	Use transistor as an electronic switch and series voltage regulator	21
4.1.167	Operate and set the required frequency using function generator	24
4.1.168	Make a printed circuit board for power supply	26
4.1.169	Construct simple circuits containing UJT for triggering and FET as an amplifier	30
4.1.170	Troubleshoot defects in simple power supplies	33
4.1.171	Construct power control circuit by SCR, DIAC, TRIAC and IGBT	39
4.1.172	Construct variable DC stabilized power supply using IC	43
4.1.173	Practice on various logics by use of logic gates and circuits	44
4.1.174	Generate and demonstrate wave shapes for voltage and current of rectifier, single stage amplifier and oscillator, using CRO	49
Module 2 : Control Panel Wiring		
4.2.175 (i)	Design layout of control cabinet, assemble control elements and wiring accessories for local and remote control of induction motor	53
4.2.175 (ii)	Design layout of control cabinet, assemble control elements and wiring accessories for forward and reverse operation of induction motor	57
4.2.175 (iii)	Design layout of control cabinet, assemble control elements and wiring accessories for automatic star-delta starter with change of direction of rotation	60
4.2.175 (iv)	Design layout of control cabinet, assemble control elements and wiring accessories for sequential control of three motors	63
4.2.176	Carryout wiring of control cabinet as per wiring diagram, bunching of XLPE cables channeling, tying and checking etc.	67
4.2.177	Mount various control elements (e.g) circuit breakers, relays, contactors and timers etc.	69
4.2.178	Identify and install required measuring instruments and sensors in control panel	70
4.2.179	Test the control panel for its performance	71
Module 3 : AC/DC Motor Drives		
4.3.180	Perform speed control of DC motor using thyristors/DC drive	72
4.3.181	Perform speed control and reversing the direction of rotation of AC motors by using thyristors/AC drive	75

CONTENTS

Exercise No.	Title of the Exercise	Page No.
4.3.182	Construct and test a universal motor speed controller using SCR	78
Module 4 : Inverter and UPS		
4.4.183	Assemble circuits of voltage stabilizer and UPS	81
4.4.184	Prepare an emergency light	84
4.4.185	Assemble circuits of battery charger and inverter	86
4.4.186	Test analyse, defects and repair voltage stabilizer, emergency light and UPS	89
4.4.187	Maintain service and trouble shoot battery charger and inverter	93
4.4.188	Install an inverter with battery and connect it in domestic wiring for operation	95
Module 5 : Power Generation and Substation		
4.5.189	Draw layout of thermal power plant and identify function of different layout element	98
4.5.190	Draw layout of hydel power plant and identify functions of different layout elements	100
4.5.191	Visit to transmission/distribution substation	102
4.5.192	Draw actual circuit diagram of substation visited and indicate various components	104
4.5.193	Prepare layout plan and identify different elements of solar power system	105
4.5.194	Prepare layout plan and identify different elements of wind power system	106
4.5.195	Assemble and connect solar panel for illumination	107
Module 6 : Transmission and Distribution		
4.6.196	Practice installation of insulators used in HT/LT lines for a given voltage range	110
4.6.197	Draw single line diagram of transmission and distribution system	114
4.6.198	Measure current carrying capacity of conductor for given power supply	116
4.6.199	Fasten, jumper in pin, shackle and suspension type insulators	118
4.6.200	Erect an overhead service line pole for single phase 240V distribution system in open space	120
4.6.201	Practice on laying of domestic service line	122
4.6.202	Install bus-bar and bus coupler on LT line	125
Module 7 : Circuit Breakers and Relays		
4.7.203	Identify various parts of relay and ascertain the operation	127
4.7.204	Practice setting of pick up current and time setting multiplier for relay operation	129
4.7.205	Identify the parts of circuit breaker, check its operation	131
4.7.206	Test tripping characteristic of circuit breaker for over current and short circuit current	133
4.7.207	Practice on repair and maintenance of circuit breaker	135
	Project Work	138

ASSESSABLE / LEARNING OUTCOME

On completion of this book you shall be able to

- **Detect the faults and troubleshoot inverter, stabilizer, battery charger emergency light and UPS etc.**
- **Plan, assemble and install a solar panel**
- **Erect an overhead domestic service line and outline various power plant layout.**
- **Examine the faults and carryout repairing of circuit breakers.**
- **Identify the control and functional switches in a C.R.O and measure the DC and AC voltage, frequency time period.**
- **Construct and test a half and fullwave rectifiers with and without filter circuits.**
- **Draw and wire up the control panel for forward/ reverse operation of an induction motor.**
- **Control speed and reverse the direction of rotation of different type of three phase induction motor using VVVF control /AC drive**

ELECTRICIAN 4TH SEMESTER SYLLABUS

Fourth Semester Duration: Six Month

Week No.	Learning outcome Reference	Professional Skills (Trade Practical) With Indicative Hours	Professional Knowledge (Trade Theory)
79	<ul style="list-style-type: none"> Assemble simple electronic circuits and test for functioning. 	160. Determine the value of resistance by colour code and identify types. (10 Hrs) 161. Test active and passive electronic components and its applications. (15 Hrs)	Resistors - colour code, types and characteristics. Active and passive components. Atomic structure and semiconductor theory.
80-81	<ul style="list-style-type: none"> Assemble simple electronic circuits and test for functioning. 	162. Determine V-I characteristics of semiconductor diode. (10 Hrs) 163. Construct half wave, full wave and bridge rectifiers using semiconductor diode. (10 Hrs) 164. Check transistors for their functioning by identifying its type and terminals. (10 Hrs) 165. Bias the transistor and determine its characteristics. (10 Hrs) 166. Use transistor as an electronic switch and series voltage regulator. (10 Hrs)	P-N junction, classification, specifications, biasing and characteristics of diodes. Rectifier circuit - half wave, full wave, bridge rectifiers and filters. Principle of operation, types, characteristics and various configuration of transistor. Application of transistor as a switch, voltage regulator and amplifier.
82-83	<ul style="list-style-type: none"> Assemble simple Electronic circuits and test for functioning. 	167. Operate and set the required frequency using function generator. (12 Hrs) 168. Make a printed circuit board for power supply. (10 Hrs) 169. Construct simple circuits containing UJT for triggering and FET as an amplifier. (12 Hrs) 170. Troubleshoot defects in simple power supplies. (16 Hrs)	Basic concept of power electronics devices. IC voltage regulators Digital Electronics - Binary numbers, logic gates and combinational circuits.
84-85	<ul style="list-style-type: none"> Assemble simple electronic circuits and test for functioning. 	171. Construct power control circuit by SCR, Diac, Triac and IGBT. (15 Hrs) 172. Construct variable DC stabilized power supply using IC. (10 Hrs) 173. Practice on various logics by use of logic gates and circuits. (15 Hrs) 174. Generate and demonstrate wave shapes for voltage and current of rectifier, single stage amplifier and oscillator using CRO. (10 Hrs)	Working principle and uses of oscilloscope. Construction and working of SCR, DIAC, TRIAC and IGBT. Principle, types and applications of various multivibrators.
86-87	<ul style="list-style-type: none"> Assemble accessories and carry out wiring of control cabinets and equipment. 	175. Design layout of control cabinet, assemble control elements and wiring accessories for: <ol style="list-style-type: none"> (i) Local and remote control of induction motor. (15 Hrs) (ii) Forward and reverse operation of induction motor. (10 Hrs) 	Study and understand Layout drawing of control cabinet, power and control circuits. Various control elements: Isolators, pushbuttons, switches, indicators, MCB, fuses, relays, timers and limit switches etc.

ELECTRICIAN 4TH SEMESTER SYLLABUS

Fourth Semester Duration: Six Month

Week No.	Learning outcome Reference	Professional Skills (Trade Practical) With Indicative Hours	Professional Knowledge (Trade Theory)
		(iii) Automatic star-delta starter with change of direction of rotation. (15 Hrs) (iv) Sequential control of three motors. (10 Hrs)	
88-89	<ul style="list-style-type: none"> • Assemble accessories and carry out wiring of control cabinets and equipment. 	176. Carry out wiring of control cabinet as per wiring diagram, bunching of XLPE cables, channeling, tying and checking etc. (15 Hrs) 177. Mount various control elements e.g. circuit breakers, relays, contactors and timers etc. (10 Hrs) 178. Identify and install required measuring instruments and sensors in control panel. (10 Hrs) 179. Test the control panel for its performance. (15 Hrs)	Wiring accessories: Race ways/ cable channel, DIN rail, terminal connectors, thimbles, lugs, ferrules, cable binding strap, buttons, cable ties, sleeves, gromats and clips etc. Testing of various control elements and circuits.
90-91	<ul style="list-style-type: none"> • Perform speed control of AC and DC motors by using solid state devices. 	180. Perform speed control of DC motor using thyristors / DC drive. (18 Hrs) 181. Perform speed control and reversing the direction of rotation of AC motors by using thyristors / AC drive. (18 Hrs) 182. Construct and test a universal motor speed controller using SCR. (14 Hrs)	Working, parameters and applications of AC / DC drive. Speed control of 3 phase induction motor by using VVVF/AC Drive.
92-94	<ul style="list-style-type: none"> • Detect the faults and troubleshoot inverter, stabilizer, battery charger, emergency light and UPS etc. 	183. Assemble circuits of voltage stabilizer and UPS. (15Hrs) 184. Prepare an emergency light. (10 Hrs) 185. Assemble circuits of battery charger and inverter. (15 Hrs) 186. Test, analyze defects and repair voltage stabilizer, emergency light and UPS. (15 Hrs) 187. Maintain, service and troubleshoot battery charger and inverter. (10 Hrs) 188. Install an Inverter with battery and connect it in domestic wiring for operation. (10 Hrs)	Basic concept, block diagram and working of voltage stabilizer, battery charger, emergency light, inverter and UPS. Preventive and breakdown maintenance.
95	<ul style="list-style-type: none"> • Erect overhead domestic service line and outline various power plant layout. 	189. Draw layout of thermal power plant and identify function of different layout elements. (5 Hrs) 190. Draw layout of hydel power plant and identify functions of different layout elements. (5 Hrs)	Conventional and nonconventional sources of energy and their comparison. Power generation by thermal and hydel power plants.

ELECTRICIAN 4TH SEMESTER SYLLABUS

Fourth Semester Duration: Six Month

Week No.	Learning outcome Reference	Professional Skills (Trade Practical) With Indicative Hours	Professional Knowledge (Trade Theory)
		191. Visit to transmission / distribution substation. (10 Hrs) 192. Draw actual circuit diagram of substation visited and indicate various components. (5 Hrs)	
96	<ul style="list-style-type: none"> • Plan, assemble and install solar panel. • Erect overhead domestic service line and outline various power plant layout. 	193. Prepare layout plan and Identify different elements of solar power system. (05 Hrs) 194. Prepare layout plan and Identify different elements of wind power system. (05 Hrs) 195. Assemble and connect solar panel for illumination. (15 Hrs)	Various ways of electrical power generation by non-conventional methods. Power generation by solar and wind energy. Principle and operation of solar panel.
97	<ul style="list-style-type: none"> • Erect overhead domestic service line and outline various power plant layout. 	196. Practice installation of insulators used in HT/LT line for a given voltage range. (5 hrs) 197. Draw single line diagram of transmission and distribution system. (5 Hrs) 198. Measure current carrying capacity of conductor for given power supply. (5 hrs) 199. Fasten jumper in pin, shackle and suspension type insulators. (10 Hrs)	Transmission and distribution networks. Line insulators, overhead poles and method of joining aluminum conductors.
98	<ul style="list-style-type: none"> • Erect overhead domestic service line and outline various power plant layout. 	200. Erect an overhead service line pole for single phase 230 V distribution system in open space. (10 Hrs) 201. Practice on laying of domestic service line. (10 Hrs) 202. Install bus bar and bus coupler on LT line. (5 Hrs)	Safety precautions and IE rules pertaining to domestic service connections. Various substations. Various terms like - maximum demand, average demand, load factor, diversity factor, plant utility factor etc.
99	<ul style="list-style-type: none"> • Examine the faults and carry out repairing of circuit breakers. 	203. Identify various parts of relay and ascertain the operation. (5 Hrs) 204. Practice setting of pick up current and time setting multiplier for relay operation. (5 hrs) 205. Identify the parts of circuit breaker, check its operation. (5Hrs) 206. Test tripping characteristic of circuit breaker for over current and short circuit current. (5 hrs) 207. Practice on repair and maintenance of circuit breaker. (5 hrs)	Types of relays and its operation. Types of circuit breakers, their applications and functioning. Production of arc and quenching.

ELECTRICIAN 4TH SEMESTER SYLLABUS

Fourth Semester Duration: Six Month

Week No.	Learning outcome Reference	Professional Skills (Trade Practical) With Indicative Hours	Professional Knowledge (Trade Theory)
100-101	Project work / Industrial visit Broad Areas: a) Battery charger/Emergency light b) Control of motor pump with tank level c) DC voltage converter using SCRs d) Logic control circuits using relays e) Alarm/indicator circuits using sensors		
102-103		Revision	
104		Examination	

Determine the value of resistance by colour code and identify the types

Objectives: At the end of this exercise you shall be able to

- identify the types of resistors by referring to the pictorial representation
- identify the colour bands, and decode the resistance value
- calculate the tolerance value by the colour band
- measure the actual value with an ohmmeter verify with calculated value.

Requirements		
Tools/Instruments		Materials
<ul style="list-style-type: none"> • Multimeter/Ohmmeter 	- 1 No.	<ul style="list-style-type: none"> • Various types of resistors (assorted values) including potentiometers of carbon track and wire-wound type.
		- as reqd.

PROCEDURE

TASK 1: Identify the type of resistor from pictorial representation

- 1 Identify the resistor's type by referring Fig 1 and write the type in Table 1.
- 2 Sketch the I.S. symbol for the identified resistor in Table 1.

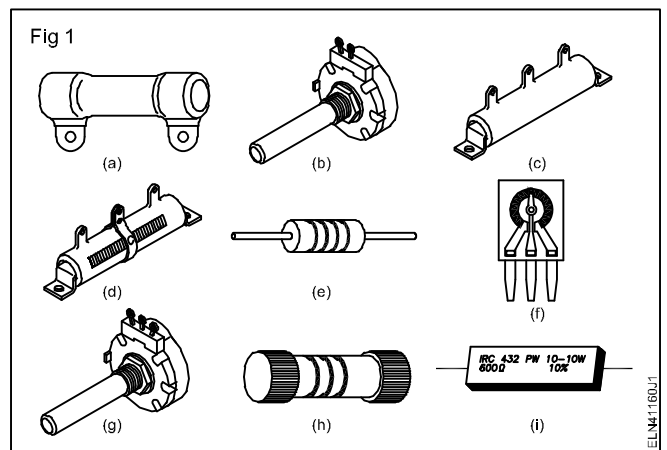
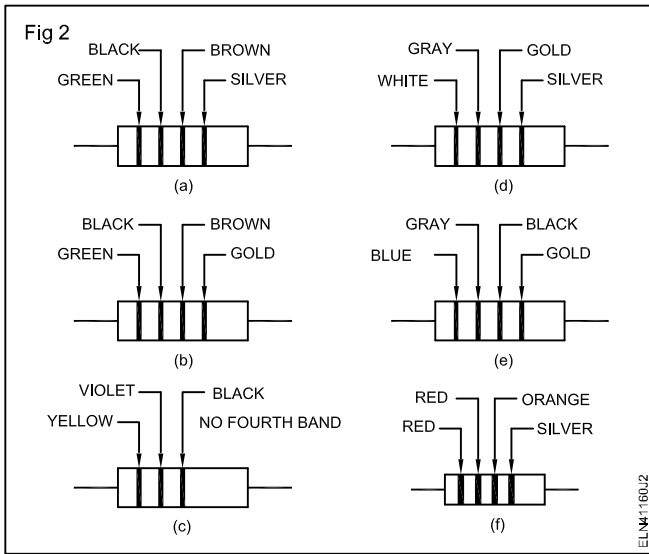

Table 1

Sl. No.	Sketch reference	Type of resistor	Symbol
1	A		
2	B		
3	C		
4	D		
5	E		
6	F		
7	G		
8	H		
9	I		

TASK 2 : Identify the colour band and decode the resistance value

1 Identify the value of resistors shown in Fig 2 from the colour bands and enter Table 2.



2 Identify the first two colour bands of the resistors given by the instructor (in sequence commencing from the 1st colour band closer to one end of the resistor - Refer Fig 3.

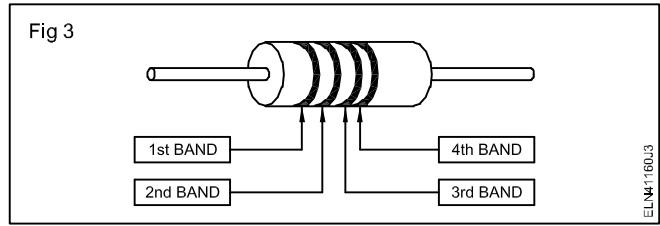

- 3 Write the 1st number and 2nd number in Table 2.
- 4 Identify the colour of the 3rd band and write the multiplier value in the respective column in Table 2.
- 5 Compute the value of the resistor and record in Table 2.
- 6 Identify the 4th band colour and fill up the tolerance in Table 2.
- 7 Determine the resistance value and the tolerance for the another given resistors and record in Table 3 by repeating the above steps 1 to 6.
- 8 Measure the value of the resistors by using a multimeter/ohmmeter and enter the values in Table 3 by following the procedure given below.

Table 2

Sl.No.	Colour				1 st No.	2 nd No.	3 rd No.	Multiplier	Resistance value	Tolerance limit (±) in percentage
	1 st Band	2 nd Band	3 rd Band	4 th Band						
A										
B										
C										
D										
E										
F										
G										

a Connect the probes

- i Connect the red probe to the POSITIVE terminal
- ii Connect the black probe to the COMMON terminal

b Set the multimeter/ohmmeter (Fig 4)

- i Set the range selector switch to one of the ohm range.

c Conduct zero ohm adjustment in analog multimeter

- i Short-circuit the two probes at the selected range.
- ii Turn the ohm adjustment knob until the pointer is set at zero ohm. (zero adjustment)

d Connect the resistor to be measured.

- i Keep your finger tips off from the probes.

- ii Maintain firm contact with the resistor lead wires.

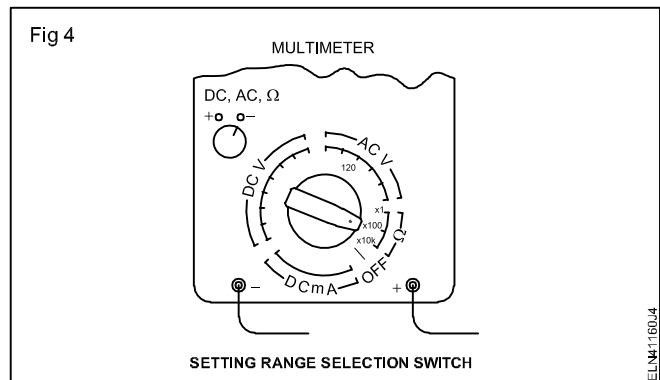

e Read the meter

- i Use a range which deflects the pointer to middle of the scale (Fig 5)

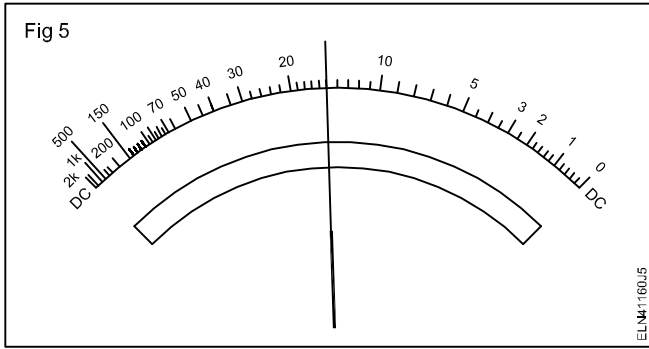

- ii Read the meter in the Ohm scale right above the pointer. (In this case 15 as shown in Fig 5)
- iii Resistance = (Ohm scale reading) x (Magnification at selected range of the resistance range).

- iv In Fig 4, the resistance range x 100 is selected, if so the value of the resistance is $15 \times 100 = 1500$ ohms = 1.5 (K Ohm)
- 9 Enter the marked value of resistance and tolerance (by the colour band over the resistor) in Table 3.
- 10 Calculate the minimum and maximum values of actual resistance for each resistor considering the tolerance marked over it. (Table 3) Record the values in Table 3.
- 11 Determine the acceptability (OK or not OK) by comparing the measured value with the minimum and maximum of the indicated value.

Note : Each range selection zero adjustment is to be ensured for correct value of resistance.

Table 3

Sl.No.	Band				Recorded resistance value	Tolerance in Ohm	Max. value of resistance	Min. value of resistance	Measured value	Remarks OK or not OK
	1 st Band	2 nd Band	3 rd Band	4 th Band %						
1										
2										
3										
4										
5										
6										
7										
8										
9										
10										

12 Report and get it checked by your instructor. _____

Test active and passive electronic components and its applications

Objectives: At the end of this exercise you shall be able to

- identify the electronic components - diode, diode bridge, transistor, SCR, IC by referring to the pictorial representation
- identify the given electronic components- diode, diode bridge, selenium bridge, transistor, IC, by visual inspection
- read the symbols for active components in the given circuit diagram
- identify the active components and their base diagram, lead configuration by referring to the data book by component code number
- decode and name the semi conductor devices - diodes transistors, SCRs
- identify the passive components by visual inspection
- interpret the coding and marking on the components
- test the components for its working conditions.

Requirements	
<p>Tools/Instruments</p> <ul style="list-style-type: none"> • Multimeters/Ohmmeter - 1 No. 	<p>Materials/Components</p> <ul style="list-style-type: none"> • Capacitors, inductors, resistors (assorted size, shape and values) - as reqd. • Assorted components of diodes, transistors, SCRs, DIACs, TRIACs, UJTs, FETs bridge diodes etc of different types with semi-conductor data manual - as reqd.

PROCEDURE

TASK 1: Identify the active components

Assumption: Given components have their code number, lead identification marks are available in data book

1 Look at the Fig 1. Identify the component from the pictorial representation. Give your response in Table 1.

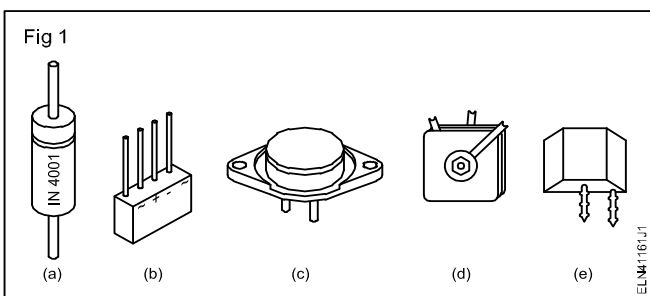

2 Write the figure Nos. that indicate the components given in Fig 2, in Table 2

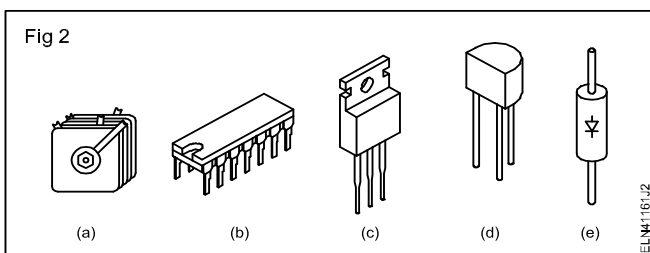

Table 1

SI.No.	Figure number	Component's name
1	Fig 1 a	
2	Fig 1 b	
3	Fig 1 c	
4	Fig 1 d	
5	Fig 1 e	

Table 2

SI. No.	Figure number	Component's name
1		Transistor with heat sink
2		Diode bridge
3		Integrated circuit
4		Diode
5		Transistor

3 Match the names and pictorial representations of the active components (Fig 3). Record your response in the space provided.

4 Collect the electronic (ACTIVE) components from your instructor. Identify the components and record your response in your record book along with sketches of the components. (Refer Fig 3 for guidance)

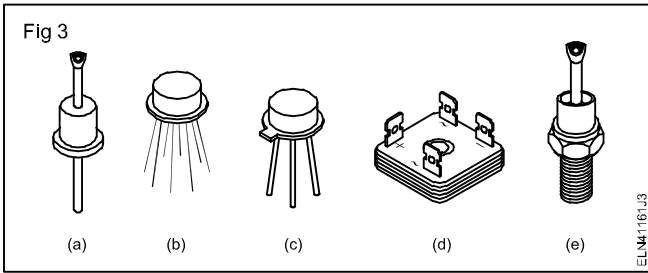

- Identify the electronic components from the given circuit diagram Nos 4,5 and 6 and write the names of the components in the Table 3.
- Decode and name the semiconductor devices from their letter designation given in Table No.4 with the help of the data book.
- Identify the leads by decoding the marking in the base diagram in the data book for the semiconductor devices.

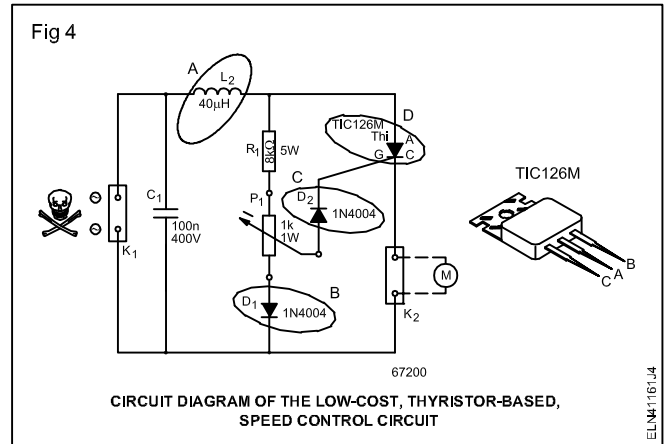

- Reproduce the base diagram with a clear sketch in Table 5.**
- Get it checked by your instructor.

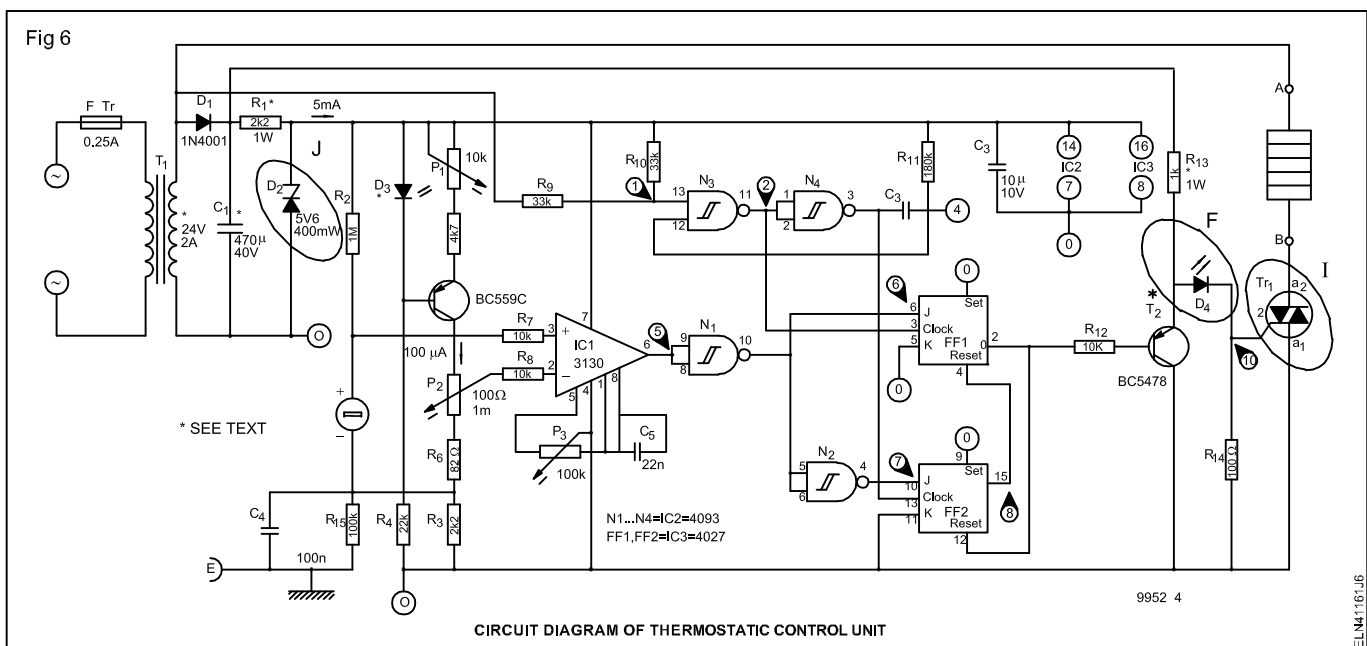
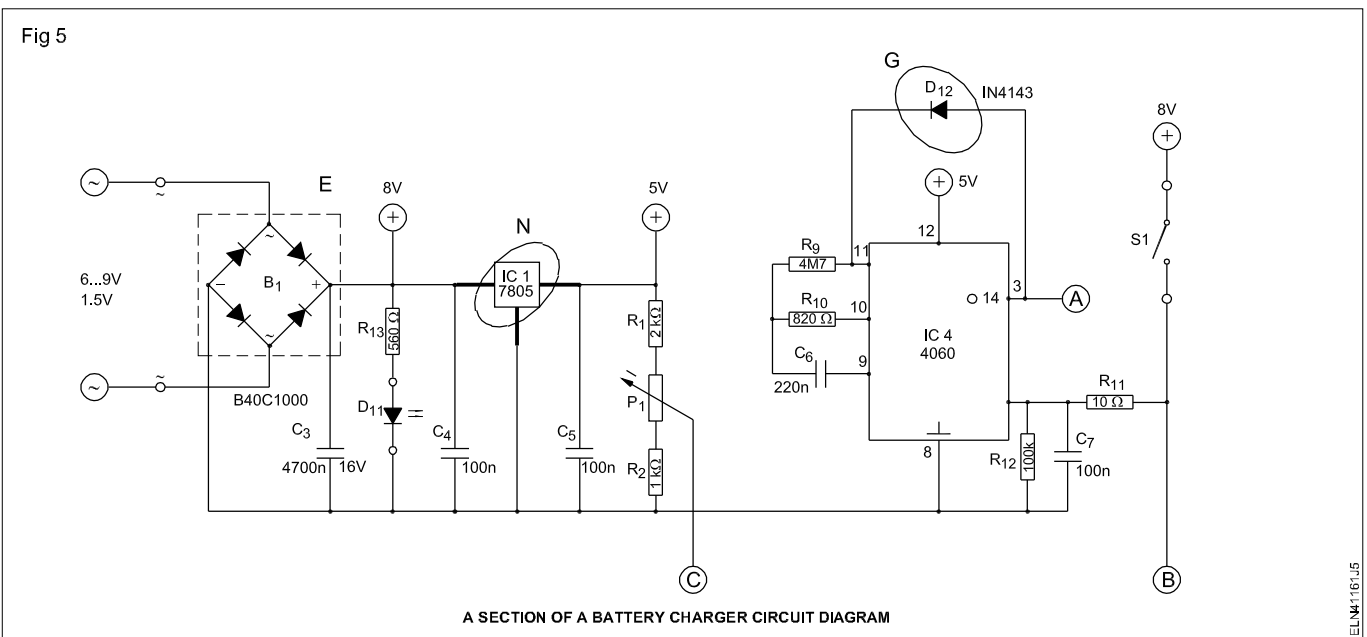

Table 3

Sl. No.	Labels	Components names	Component's symbol
1	A		
2	B		
3	C		
4	D		
5	E		
6	F		
7	G		
8	H		
9	I		
10	J		

Table 4

Sl. No.	Code No. of components	Component's name
1	OA79	
2	DR25	
3	IN4007	
4	AA119	
5	BY127	
6	BZ148	
7	BC147	
8	2N904	
9	BD115	
10	BFW10	
11	3N187	
12	BTY87	
13	2N2646	
14	D3202Y	
15	T2801B	
16	CA741	
17	CA723	
18	NE555	

Table 5

Sl.No.	Code No.	Base diagram
1	IN4007	
2	SL100	
3	BC147	
4	2N5296	
5	2N3035	
6	SN204	
7	2N2646	
8	3N187	

TASK 2 : Identify and check the passive components

Instructor shall select the resistors, inductors and capacitors so that, few can be visually identified and other can be identified by coding only.

- 1 Identify the passive components referring to Fig 1 and write the type of passive component in Table 1.
- 2 Sketch the appropriate symbol against the corresponding type of passive components in Table 1.
- 3 Get your result corrected by your instructor.
- 4 Collect assorted size, shape and type of passive components from your instructor.

- 5 Divide the passive components into separate groups as resistor, inductor and capacitor by their appearances (or) code references.
- 6 Interpret, the code references of resistor and list them in Table 2.
- 7 Measure the value of resistance of each by multimeter and record in Table 2.
- 8 Interpret the code references of capacitor and list them in Table 3.
- 9 Check the capacitor for charge and discharge by multimeter, and record the condition in Table 3 by referring Fig 7.

Table 1

Sl. No.	Fig alphabets	Components identified as	Reasons for identifications	Symbols	Remarks
1	A				
2	B				
3	C				
4	D				
5	E				

Sl. No.	Fig alphabets	Components identified as	Reasons for identifications	Symbols	Remarks
6	F				
7	G				
8	H				
9	I				
10	J				
11	K				
12	L				
13	M				
14	N				
15	O				
16	P				

Table 2

Sl. No.	Coded reference	Type of resistors and other details	Measured value of resistor
1			
2			
3			
4			
5			
6			

In case of very low value of capacitors, multimeter may not show any deflection during charge or discharge. Anyhow if the multimeter reading is infinity the capacitor has to be considered as good in case of non electrolytic capacitors.

10 Interpret the code references of inductors/ coils / transformers and list them in Table 4.

11 Check the continuity of the coil and its tapping with the multimeter and record the condition in Table 4.

There should not be any continuity between coil and the core

12 Get the above observation approved by your Instructor.

Table 3

Sl. No.	Coded reference	Type of capacitors and other details	Condition of capacitor
1			
2			
3			
4			
5			
6			

Table 4

Sl. No.	Coded reference	Type of inductors /coils transformers and other details	Condition of coil
1			
2			
3			
4			
5			
6			

Fig 7

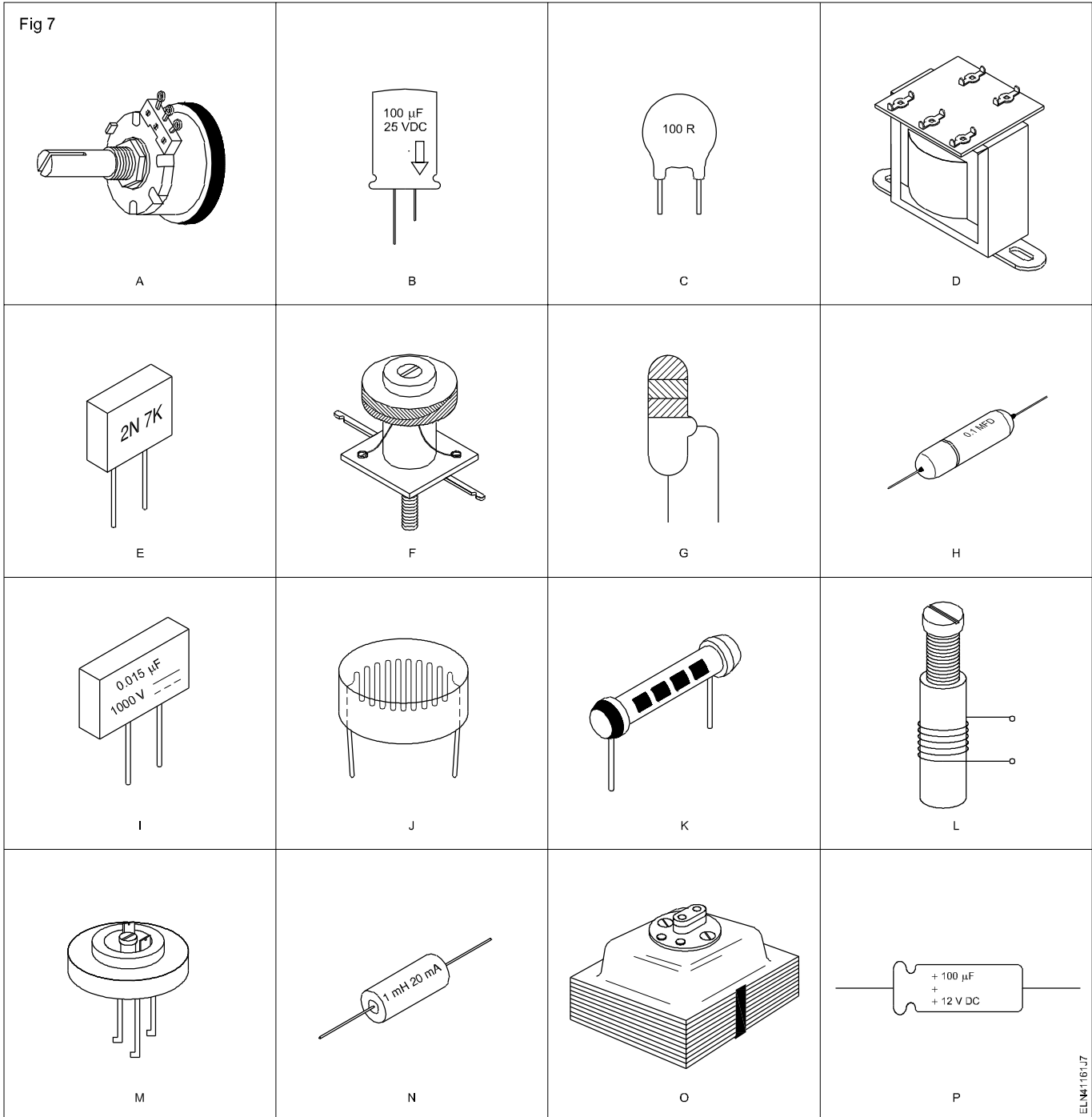

ELN41161J7

Determine the V-I characteristics of semi conductor diode

Objectives: At the end of this exercise you shall be able to

- refer data book and
 - a) identify the diode is Ge, Si etc
 - b) verify operating voltage and current rating
 - c) list the application of the diode
- identify the terminals of a diode and test the diode for its condition
- plot the forward characteristics, determine the forward resistance of the diode and the barrier potential
- plot the reverse characteristics of the diode and determine the minority carrier current.

Requirements			
Tools/Instruments		Materials	
• Multimeter (Digital)	- 1 No.	• Assorted types of diodes including IN 4001 or IN 4007	- as reqd.
• Voltmeter MC 0-1 V	- 1 No.	• 570 Ω , 5W potentiometer	- 1 No.
• Milliammeter MC 0-25 mA	- 1 No.	• SPST switch 6A 250V	- 1 No.
• Voltmeter MC 0-30 V	- 1 No.	• Bread board 150 x 150 mm	- 1 No.
• Micro ammeter MC 0-100 Micro Amp	- 1 No.	• Suitable connecting wires for bread board	- as reqd.
• Semi conductor diode data book	- 1 No.	• Patch cords with clips	- 2 sets
Equipment/Machines		• 100 Ω 1/4 W resistor	- 1 No.
• DC regulated power supply 0- 30 V, 1 A	- 1 No.	• 10 Ω 1/4 W resistor	- 1 No.

PROCEDURE

TASK 1: Refer the diode with data book

- 1 Select any one of the given assorted diodes. Record the type number printed on the diode in the Table 1.
- 2 Refer diode data book and search for the type number of the selected diode.
- 3 In data book check for the column which indicates Material or mat. against the referred diode. Record the type of semiconductor used following the tips given below:
 - Under the column material or mat,
 - if code S or Si is printed it means the material used for making the diode is silicon.
 - if code G or Ge - Germanium
 - if code Se - Selenium
- 4 Look in the data book for the column which indicates Rated peak reverse voltage abbreviated as V_R or V_f or PIV against the referred diode. Find and record the indicated value of rated peak reverse voltage in Table 1.
- 5 Get as done in step 4 and record the following specifications of the referred diode from the data book:
 - I_f of I_f - Maximum average forward current
 - V_f of V_f - Forward voltage drop at specified I_f
 - I_s - Maximum forward surge current
 - I_{VT} - Maximum reverse current at V_R
 - Function - Normal use/application of the diode.

The coding used for Function differs from data book to data book. Consult instructor in case of difficulty.
- 6 Repeat steps 1 to 5 for atleast ten different types of given diodes.
- 7 Refer diode data book or diode equivalents data book and identify one or two equivalent diode types for each diode. For those diodes you collected the specification.
- 8 Get your work checked by your instructor.

Table 1

Diode specification

Sl. No.	Type No. of diode	Material	Rated peak reverse voltage V_R	Max. reverse current I_V	Max. average forward current I_F	Forward voltage current V_F	Max. forward surge	Application	Equivalent diode type current I_s

TASK 2 : Identify the terminal leads of a given diode

- 1 Set the multimeter in ohms range ($W \times 1$). Connect its leads to a M.C. voltmeter (0-3V), to find out the polarity of multimeter output voltage.

In digital multimeter the marked polarity and polarity of output voltage are the same.

- 2 Check the deflection of the voltmeter, if it indicates the voltage, mark the terminal of the multimeter corresponding to the voltmeter polarity
- 3 Mark the terminal of the multimeter opposite to voltmeter polarity. If the voltmeter kicks back then.
- 4 Connect the +ve marked terminal for the multimeter to one terminal of the diode and other to the -ve and observe the reading.
 - a) If the meter reads low resistance then the lead of the diode connected to +ve marked terminal of the meter is the ANODE and the other is cathode. (Fig 1a)
 - b) If the meter does not deflect as in Fig 1b then the lead of the diode connected to +ve marked terminal for the multimeter is the cathode and the other is anode.

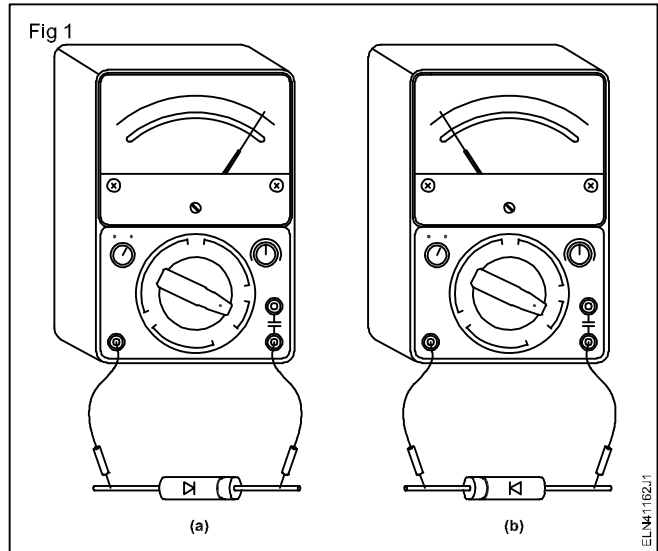

If the meter reads low resistance for both polarities the diode is short.
If the meter reads high resistance for both polarities the diode is open.

TASK 3 : Determine the forward V-I characteristic of the diode

- 1 Construct the circuit in the bread board as in Fig 2.
- 2 Set initially $V_B = 0$ and switch ON the power supply.
- 3 Set $V_B = 5V$, set the potentiometer to minimum position.
- 4 Close the switch S and adjust potentiometer to increase the voltage across the diode in steps of 0.1 V as per the Table. 1
- 5 Record the corresponding values of current read by the ammeter in the Table. 1.

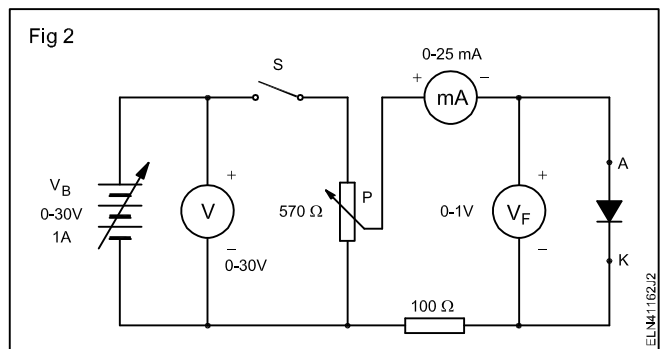

Table 1

V _F Volt	0	0.1	0.2	0.3	0.4	0.5	0.6	0.7	0.8	0.9	1.0	2.0
I _F mA	0											

- Check the value of voltage across the diode at which the current starts increasing and remain constant at later.
- Switch OFF the supply
- Plot the graph with V_F on X axis and I_F on Y- axis.
- Determine the forward resistance.

$$R_F = \frac{V_F}{I_F} \text{ ohms}$$

From the graph determine the knee point voltage at which large quantity of current starts flowing. Enter the value below.

Knee point voltage volts If the knee point voltage is around 0.3 V or 0.7V the diode is germanium or silicon respectively.

Note : Increase the voltage beyond 2.0V as indicated in case diode is not reached in saturation current.

TASK 4 : Determine the reverse V-I characteristic of a diode

- Construct the circuit in a bread board as in Fig 3. (Reverse the Diode terminals with respect to previous task)

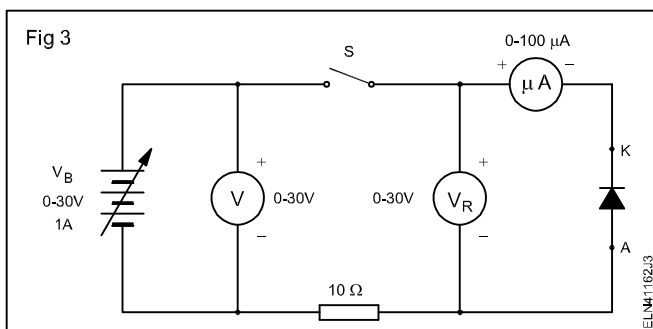

- Switch on the power supply and close the switch S.

- Increase the voltage gradually across the diode by operating the power supply as per Table 2 and note down the corresponding current read by the ammeter in Table 2.
- Switch OFF the power supply.
- Plot the graph on the same graph sheet (Task 3) with V_R on x-axis and I_R on Y-axis.
- Determine the minority carrier current from the graph.

If the reverse voltage becomes equal to the PIV of the diode then the diode starts conducting and not to increase the voltage beyond PIV of the diode.

- Repeat the experiment for different type of diodes.

Table 2

V _R Volts	0	5	10	15	20	30
I _R in Micro camps						

Construct half-wave, full wave and bridge rectifiers using semi conductor diode

Objectives: At the end of this exercise you shall be able to

- **construct a half-wave rectifier and test**
- **construct and test a full-wave rectifiers using two diodes**
- **construct and test bridge type, full wave rectifiers using four diodes.**

Requirements			
Tools/Instruments			
• Trainees kit	- 1 No.	• Multi strand wire, red, blue 23/0.2 of 650V grade	- as reqd.
• Soldering iron 25W/250V	- 1 No.	• Base board	- 1 No.
• Voltmeter MC 0-30V	- 1 No.	(Laminated board 30x15x3mm)	
• Multimeter (Digital)	- 1 No.	• Mains cord 3 core cable 23/0.2 of 650V grade	- 1 No.
Materials/Components			
• Lug board General purpose 5 points	- 1 No.	• Nuts, bolts and washers	- as reqd.
• Diode IN4007	- 4 Nos.	• 3 Pin plug 6A 250 V	- 1 No.
• Resistor 470Ω (Ohm)	- 1 No.	• Resin core solder 60/40	- as reqd.
• Step-down transformer, 240V/12.0.12, 500mA	- 1 No.		

PROCEDURE

TASK 1: Construct half-wave rectifier and test it

- 1 Test the continuity of the primary and secondary windings of the given transformer. Record the specifications of the given transformer.
- 2 Follow the order of steps given below by referring Fig 1.
 - Mount the tested transformer as shown in Fig 1 on BASE BOARD using suitable size nuts, washers and bolts. Get it checked by your instructor.
 - Mount the rectifier diode on lug board by soldering
 - Solder the wire connection and the three core power cord. (Fig 1a & Fig 1b)
- 3 Connect AC mains to the board and switch ON mains. Measure and record the mains voltage and transformer secondary voltage $V_{S(rms)}$ (AC input to rectifier) in the Table 1.
- 4 Calculate and record the calculated DC voltage across load R_L using the formula,

$$V_{dc} = 0.45 V_{S(rms)}$$

where, $V_{S(rms)}$ is the AC input to the rectifier.

- 5 Measure and record the rectified DC voltage V_{dc} across load R_L using multimeter.
- 6 Record the difference in the calculated and measured values.
- 7 Get it checked by your instructor.

Transformer specifications

Rated primary voltage	
Rated secondary voltage	
Secondary current or VA rating of transformer	
Type of transformer step-up/step down	
No. of windings in secondary	

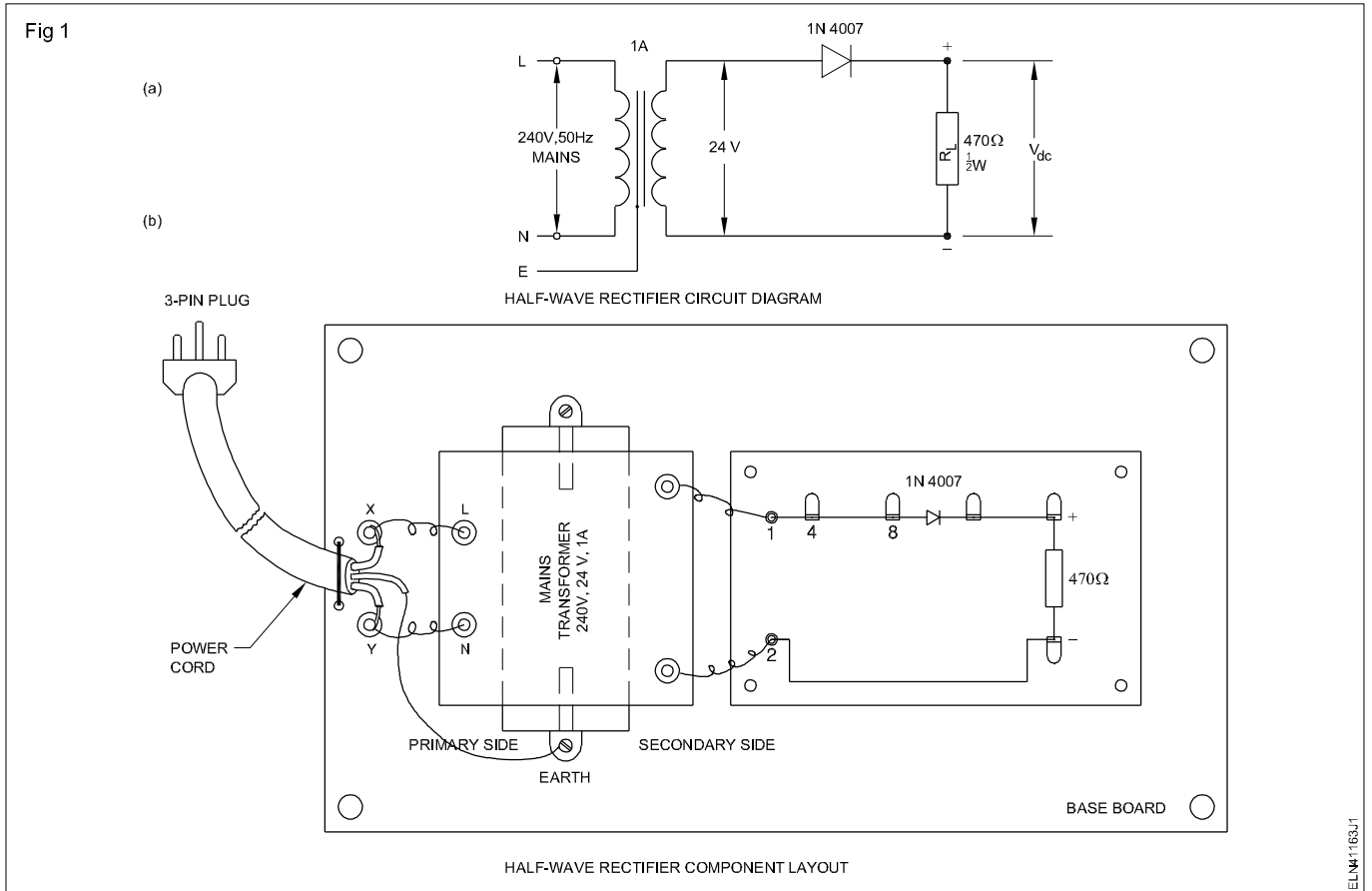

Table 1

Readings of single diode half wave rectifier

$V_{s(rms)}$	Calculated V_{dc} volts	Measured V_{dc} volts	Difference of (2) & (3)	Peak value of V_s	Frequency of V_s
(1)	(2)	(3)	(4)	(5)	(6)

TASK 2 : Construct fullwave rectifier with centre tap transformer

- 1 Check to confirm good condition of the given components. Record specifications of the transformer.
- 2 Construct a full wave rectifier circuit as shown in the schematic and layout diagram at Fig 2a & Fig 2b.
- 3 Switch ON the circuit. Measure the AC input voltage $V_{s(rms)}$ to the rectifier across the centre-tap and any one end of the transformer and record it in Table 2.
- 4 Calculate the expected DC voltage V_{dc} across load R_L using the formula given below;

Transformer specifications

1 Rated primary voltage	---
2 Rated secondary voltage between centre tap and one end	---
3 Rated secondary current or VA rating transformer	---

In full wave rectifier, $V_{dc} = 0.9 V_{s(RMS)}$ where, $V_{s(rms)}$ is the voltage across the centre-tap and any one end terminal of secondary. Record the value in Table 2.

- 5 Measure the rectified output V_{dc} across load R_L and record it Table 2.

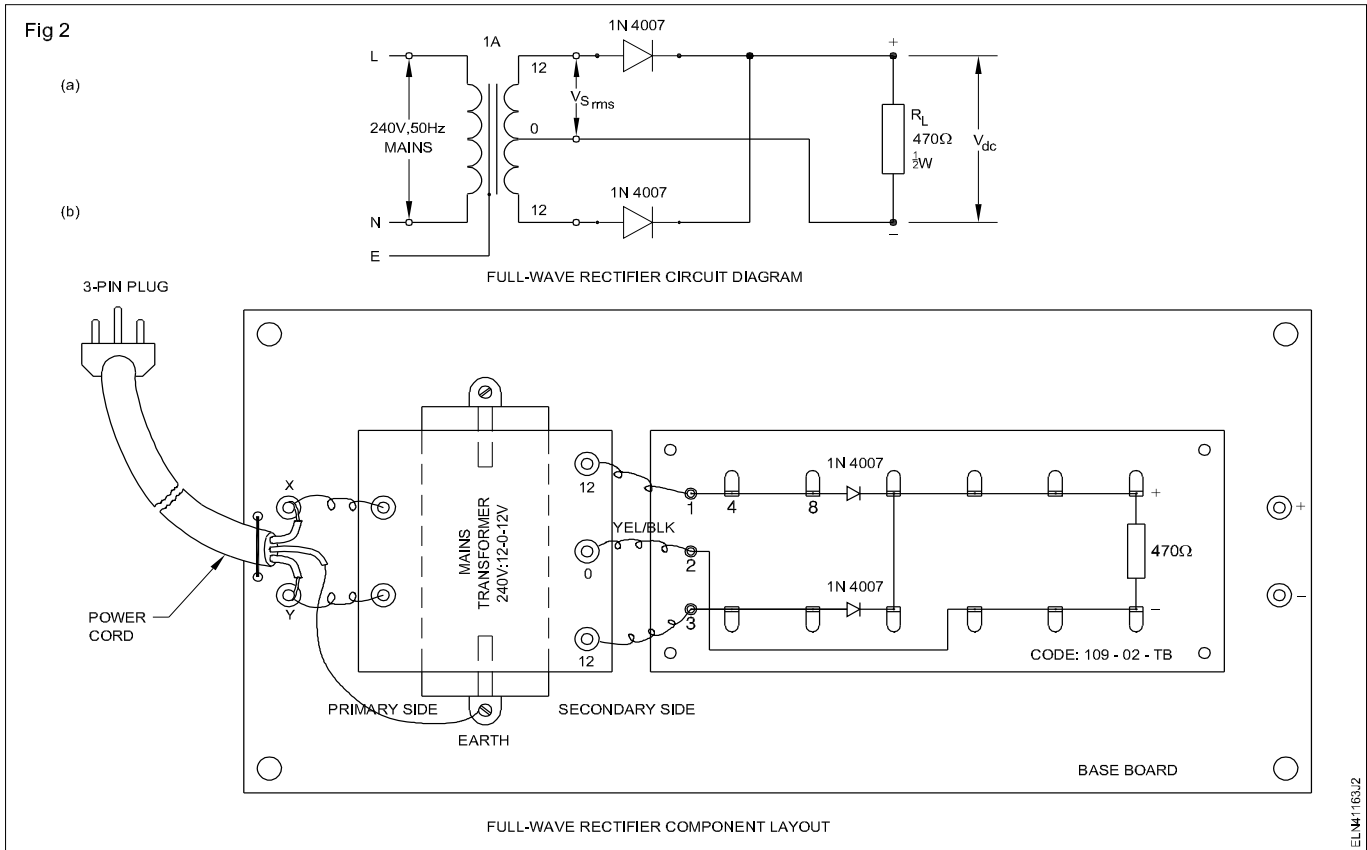

6 Calculate and record the difference in the calculated and measured V_{dc} values. Get it checked by your instructor.

Table 2

Readings of two-diode full-wave rectifier

$V_{s(rms)}$	Calculated V_{dc} volts	Measured V_{dc} volts	Difference of (2) & (3)	Peak value of V_s	Frequency of V_s
(1)	(2)	(3)	(4)	(5)	(6)

TASK 3 : Construct bridge rectifier

- Modify the two diode full wave rectifier wired in Task 2 to construct a bridge rectifier, referring to the schematic and layout diagrams (Fig 3a & Fig 3b).
- Switch On the circuit. Measure and record the AC input $V_{s(rms)}$ to the rectifier in Table 3.
- Calculate the expected output DC voltage V_{dc} across load R_L using the formula, In a bridge rectifier.
 $V_{dc} = 0.9 V_{s(rms)}$ where, $V_{s(rms)}$ is the AC input to the rectifier (refer Fig 3). Record the value in Table 3.

Table 3

Readings of bridge rectifier

$V_{s(rms)}$	Calculated V_{dc} volts	Measured V_{dc} volts	Difference of (2) & (3)	Peak value of V_s	Frequency of V_s
(1)	(2)	(3)	(4)	(5)	(6)

4 Measure the DC output V_{dc} across the load R_L and record it in Table 3.

5 Record the difference in the calculated and measured values in Table 3.

6 Report and get it checked by your instructor.

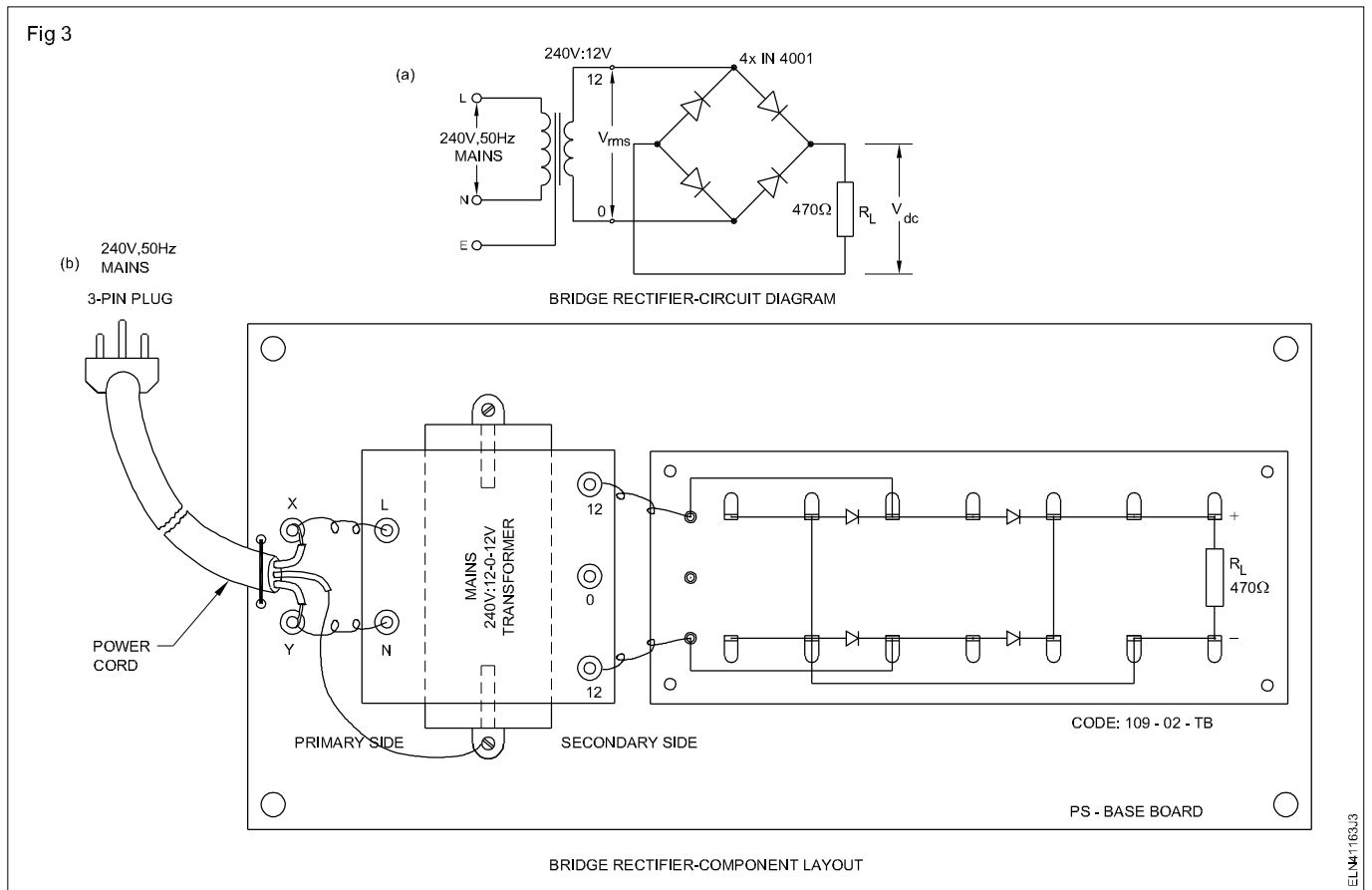

Check transistors for their functioning by identifying its type and terminals

Objectives: At the end of this exercise you shall be able to

- identify a transistor from its type-number the following information referring to a data book;
 - a) silicon or germanium
 - b) PNP or NPN
 - c) package type
 - d) base, emitter, collector pins.
- test the condition of a given transistor using ohmmeter/multimeter.

Requirements			
Tools/Instruments		Materials/Components	
• Trainees kit	- 1 No.	• Assorted type of transistors	- 10 Nos
• International transistors data book	- 1 No.	• Sleeve wires of red, yellow, blue and black colours 1mm dia	- as reqd.
• Ohmmeter/multimeter	- 1 No.		

PROCEDURE

TASK 1 : Identify transistor type and leads, referring to data manual

- 1 Take any one transistor from the given assorted lot (Fig 1), enter its label number and transistor type number in Table 1.
- 2 Refer to transistor data manual, find and record the following details of the transistor in Table 1
 - Whether silicon or germanium
 - Whether NPN or PNP
 - Type of packaging or case outline (Example: TO5, TO7 etc.)

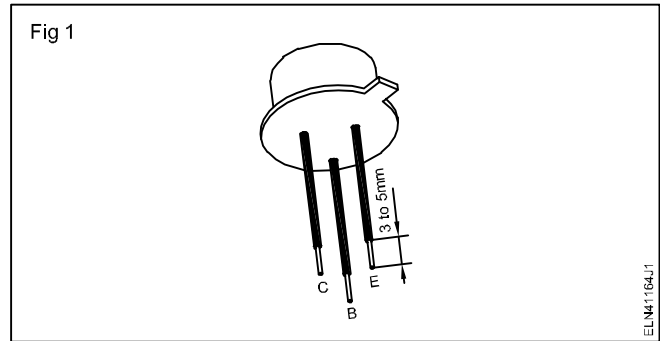

Table 1 (With sample data)

Label No.	Transistor type No.	Semi-Conductor /type	Type of package	Pin Diagram	Junction resistance	
					E-B in forward bias E-B	B-C in reverse bias (E-B & B-C)
Sample	BC107	Si/NPN	T018		Low	Very High

- 3 From the type of package recorded, refer to the transistor data manual and draw the pin diagram indicating base, emitter and collector for the transistor in Table 1.
- 4 Put sleeves of suitable length (Fig 1) to the identified pins of the transistor using the colour scheme given below:

Base : Blue colour sleeve
 Emitter : Red colour sleeve

Collector : Yellow colour sleeve
 Shield : Black colour sleeve

In power transistors, the metal body itself will be the collector. In such cases, mark 'C' on the metal body using a pencil. All transistors will not have shield pin.

- 5 Repeat steps 1 to 4 for atleast five transistors of different types in the given lot and get your work checked by your instructor.

TASK 2 : Check the transistor for PNP or NPN type

Referring a data book with respect to transistor number gives the information whether transistor is PNP or NPN. In the absence of data book this test will be useful.

- 1 Ascertain the +ve and -ve polarity of the ohmmeter leads.
- 2 Hook the negative lead of the ohmmeter test prod to the base and the positive lead of the ohmmeter to emitter of the transistor.

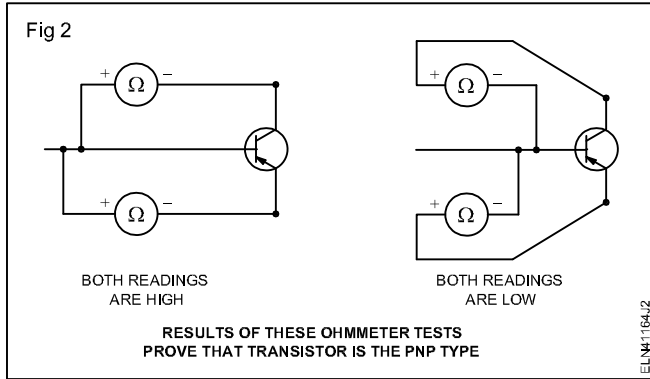

- 3 Read the resistance value.

A low reading shows the transistor is PNP and the high reading shows the transistor is NPN provided the condition of the transistor is good. Refer Fig 2 and 3.

- 4 Record your findings in Table 2 and mark the identified type and condition.

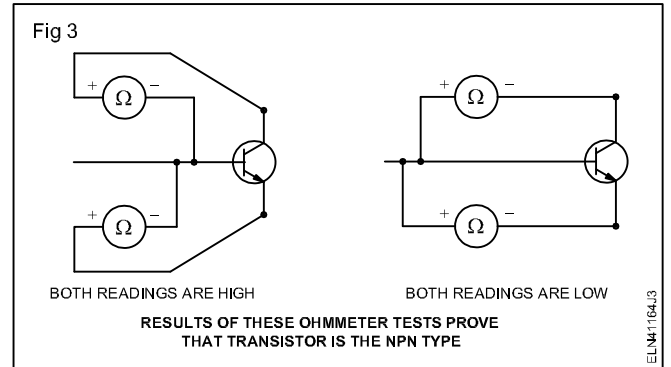

Table 2

Transistor No.	Forward bias		Ohmmeters reading	Reverse bias		Ohmmeters reading	Transistor Type	Remarks
	+Ve	-Ve		+Ve	-Ve			
AC128	E	B	Low	C	B	Low	PNP	Good
	B	E	High	B	C	High		

TASK 3 : Test transistor for its working condition

- 1 Identify which terminal of the ohmmeter being used is connected to the +ve terminal of the internal battery of the meter. Set the meter range to RX100Ω.

Ohmmeters in very low or very high ohms range can produce excessive current/voltage and may damage low power transistors while testing.

- 2 Take a transistor whose pins are identified and sleeved at Task 1. Depending on whether the chosen transistor is NPN or PNP, clip/hold the +ve or -ve of the meter prod to the base of the transistor as shown in Fig 4a and 4b.
- 3 Clip the other meter prod to the emitter. Check if the base-emitter junction diode of transistor shows low resistance (few tens of ohms) or very high resistance (few tens of kilohms). Record your observation in Table 3.
- 4 Reverse the polarity of the prod connected across the base-emitter and check if the base-emitter junction diode of transistor shows low resistance or very high resistance. Record your observation in Table 3.

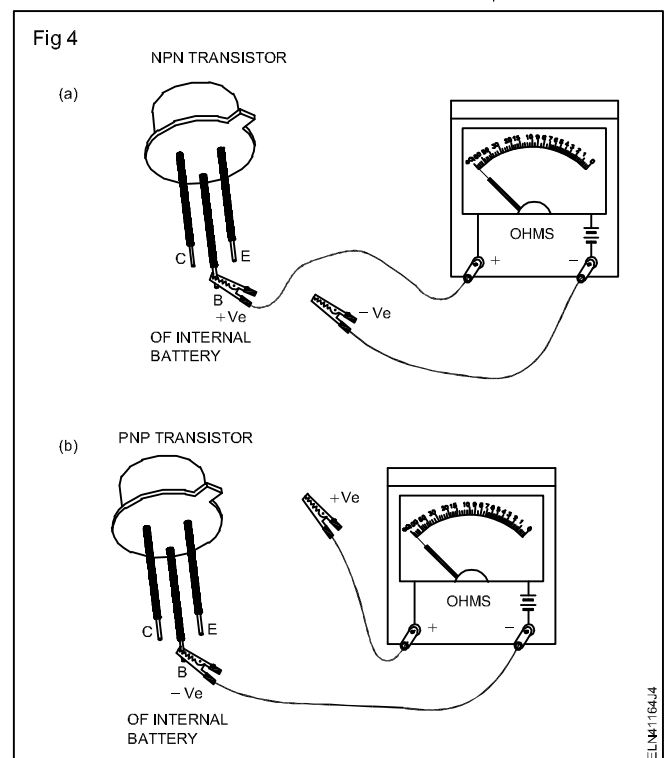

- 5 From the recorded observations in steps 3 and 4, and referring to the table given below, conclude and record, the condition of the base-emitter junction diode of the transistor as GOOD, open or shorted in Table 3.

If the resistance of the junction measured in both directions is high, in addition to the condition of the junction given in table, another possibility is, your identified base pin may be wrong. You may be measuring resistance across emitter-collector. In case of doubt, recheck the identified pins of the transistor and repeat steps 2,3 and 4.

- 6 Repeat steps 2,3,4, and 5 and check the condition of the base-collector junction diode of the transistor.
- 7 Measure the resistance across the emitter-collector and record the observation as V-HIGH ($> 1M\Omega$) or LOW ($< 500\Omega$).

In a good transistor the resistance between the emitter and collector will be very high. A low resistance indicates that the transistor is leaky.

- 8 Clip the meter across the emitter-collector with correct polarity as in Fig 5. Touch the base-collector with moist finger as in Fig 5 and check if the resistance shown by the meter decreases indicating that the transistor is turning ON. Record your observation as YES or NO in Table 3.
- 9 From the observations recorded at steps 5,6,7 and 8, give your conclusion on the overall condition of the transistor under test. Refer Table 3.
- 10 Repeat the steps 1 to 9 for atleast five more transistors of different types.
- 11 Report and get your work checked by your instructor.

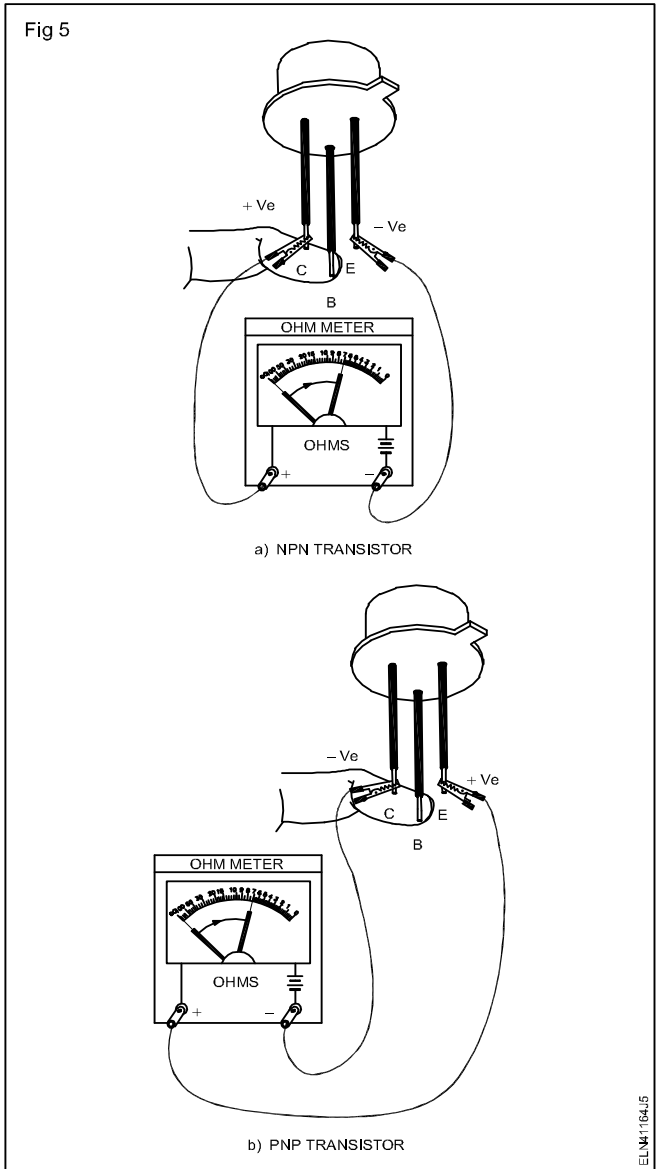

Table 3

Resistance of P - N junction with meter prods in one direction	Resistance of P - N junction with meter in reversed direction	Condition of P - N Junction
Low	Very High	Good
Low	Low	Shorted
Very High	Very High	Open (see Note above)

Bias the transistor and determine its characteristics

Objectives: At the end of this exercise you shall be able to

- wire up and test a fixed-bias transistor amplifier
- wire up and test a emitter-bias transistor amplifier
- wire and test a voltage divider-bias transistor amplifier
- draw characteristics curve with respect to base current with collector current in all conditions.

Requirements			
Tools/Equipments/Instruments			
• Trainees kit	- 1 No.	• Tag board code no.110-03-TB	- 1 No.
• DC millammeter, 0 - 1 mA	- 1 No.	• Resistors, Carbon, 1/4 W	
• DC millammeter, 0- 100 mA	- 1 No.	120 Ω	- 1 No.
• Regulated power supply, 12V, 1A	- 1 No.	470 Ω	- 1 No.
Materials/Components		1K Ω	- 2 Nos
• SL100 or equivalent metal can transistors	- 2 Nos.	5.6K Ω	- 1 No.
		182K Ω	- 1 No.
		330K Ω	- 1 No.

PROCEDURE

TASK 1: Wire up and test fixed bias transistor amplifier

- 1 Construct the circuit (Fig 1) on the tag board. Identify the type of biasing used in Fig 1 and record in Table 1

Use the transistor having low β value, (around 100)

- 2 Switch ON 12V, DC supply to the circuit. Measure and record values of I_B , I_C , V_{BE} and V_{CE} in Table 1.

The readings taken are at normal room temperature.

- 3 Hold the heated barrel of the soldering iron close to the transistor (but not touching) for 30 sec to 1 min and observe the change in the collector current. Record the changed value of I_B , I_C , V_{BE} and V_{CE} at elevated temperature of the transistor.

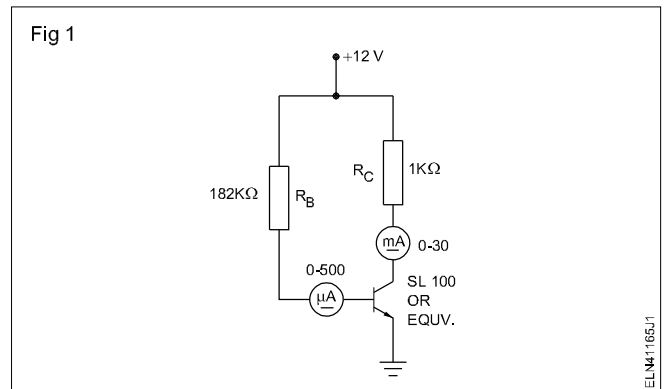

The transistor is heated to observe the effect of heat on the set Q point of the transistor.

Table 1

Fixed bias transistor amplifier

Description	I_B μA	I_C mA	V_{BE} volt	V_{CE} volt
Reading taken at room temperature				
Readings taken at elevated temperature				

- 4 Get your readings checked by your instructor.
- 5 Switch OFF, power to the circuit. Modify the wired circuit to that in Fig 2. Identify the type of biasing used in Fig 2 and record in Table 2.
- 6 Switch ON DC supply to the circuit. Measure and record I_B , I_C , V_{BE} and V_{CE} in Table 2.
- 7 Repeat step 3 and 4.
- 8 Switch OFF DC supply to the circuit. Modify the wired circuit to that shown in Fig 3. Identify and record the type of biasing used in Fig 3 in Table 3.

Use the transistor having low β value (around 100)

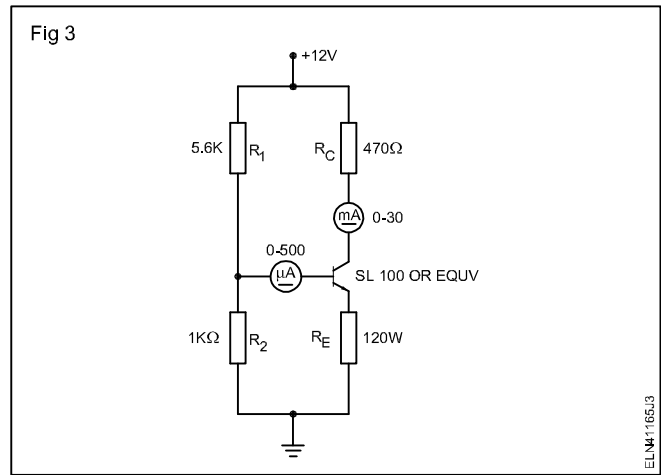
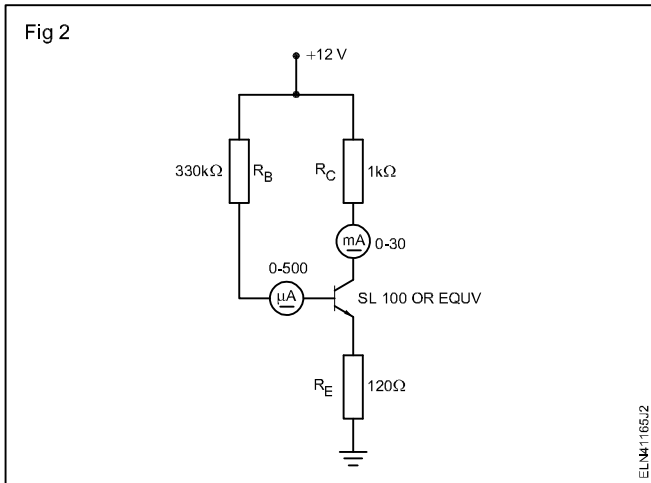

Table 2

Emitter bias transistor amplifier

Description	I_B μA	I_C mA	V_{BE} volt	V_{CE} volt
Reading taken at room temperature				
Readings taken at elevated temperature				

Table 3

Voltage divider bias transistor amplifier

Description	I_B μA	I_C mA	V_{BE} volt	V_{CE} volt
Reading taken at room temperature				
Readings taken at elevated temperature				

- 9 Repeat steps 2,3, and 4 and record the readings in Table 3
- 10 Write the conclusion based on the types of bias and stability of current value at collector and base when the circuit is heated.

- 11 Report and get your readings and graph checked by your instructor.

- 12 Draw the characteristics curve base current V_s collector current in both cases. (Room temperature and relevant temperature) in the same graph (two curves in one graph).

Use transistor as an electronic switch and series voltage regulator

Objectives: At the end of this exercise you shall be able to

- determine the minimum forward bias current required to switch the transistor from OFF to ON condition
- construct transistorised series voltage regulator and test
- measure ripple at input and out put of the regulator and find ripple factor.

Requirements			
Tools/Instruments			
• Ammeter MC - (0-100 milliamp)	- 1 No.	• Variable resistor 250K 1 W	- 1 No.
• Ammeter MC (0-100 microamp)	- 1 No.	• Bread board	- 1 No.
• Voltmeter MC (0-15 V)	- 1 No.	• Connecting leads	- as reqd.
• Trainees Kit		• Dry cell 1.5 V	- 1 No.
• Unregulated DC power supply 0-30VDC/1A	- 1 No.	• Tag board (Code no. 111-01-TB)	-1 No.
CRO, 20 MHz	- 1 No./ batch	• Transistor SL 100 or equivalent	- 1 No.
		• Zener diode, 12V, 1/4W	- 1 No.
		180Ω	- 1 No.
		1KΩ	- 2 Nos.
		220 Ω	- 1 No.
		330 Ω	- 1 No.
Equipment/Machines		• Capacitor, 10μF, 25V	- 1 No.
• DC regulated power supply; 0-30 V 1amp	- 1 No.	• LED, Red colour	- 1 No.
		• Hook up wires (Red and Black) each	- 1 Meter
Materials		• Rosin core solder	- 20 cms.
• Transistor BC 107	- 1 No.		
• Lamp 6V, 150 mA	- 1 No.		

PROCEDURE

TASK 1: Perform the using of the transistor as an electronic switch

- 1 Collect the specifications from the data book for the transistor used in the circuit diagram. (Fig 1)
- 2 Form the circuit as per the given circuit diagram (Fig 1)

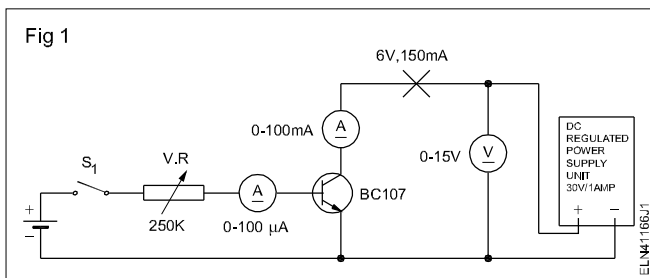

Check for the specific range of instruments and correct polarity.

Keep the supply OFF and the voltage knob of power supply unit at 0V.

- 3 Switch ON the power and set the collector supply to 10V by operating the voltage knob.
- 4 Switch ON the battery supply by closing the switch S_1 to the base-emitter circuit.
- 5 Adjust VR for base current of 5 microamps and note the collector current and record it in Table 1.
- 6 Change I_b to 90 microamps insteps as in the Table 1.

Table 1

Base current in micro-ampere	5	10	20	30	40	50	60	70	80	90
Collector current in milliampere										
State										

- Check the value of I_b for which I_c has not changed, (i.e. I_c is saturated).
- Vary the I_b base current between the two readings to find the exact value of I_b at which I_c reaches saturation.
- Set the I_b to a value just above minimum to cause I_c saturation and check for 'ON' 'OFF' action by operating switch S_1 . Switch OFF power supply.
- Connect a lamp 6V, 150mA in the collector circuit as in Fig 1 and switch 'ON' the power supply.
- Check lamp glowing; if not slightly adjust the base current to increase till the lamp 'ON'.
- Confirm the lamp operation by operating base current of Transistor.

- Draw the base to the collector current graph, and mark the states of the transistor. (Fig 2)

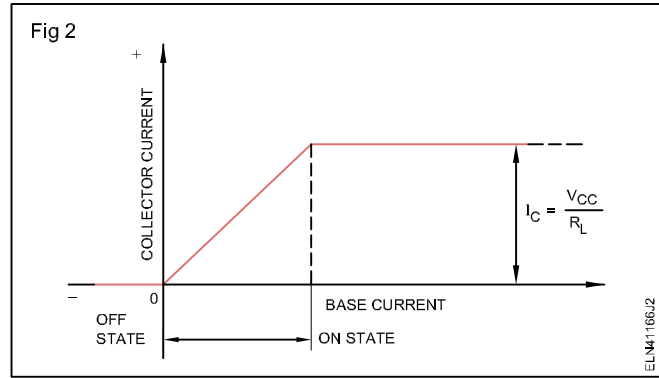

TASK 2 : Construct transistorised series voltage regulator

- Refer data book and record the required details of the given transistor in Table 2.

Table 2

Sl.No.	Input P.S voltage in volts	O/P P.S voltage in volts	Remarks
1	6		
2	8		
3	10		
4	12		
5	14		
6	16		

- Test to confirm the condition of the given components.
- Solder the components on the given Tag board as per the schematic diagram and layout shown in Fig 3 and 4 respectively. Get the wired circuit checked by your instructor.

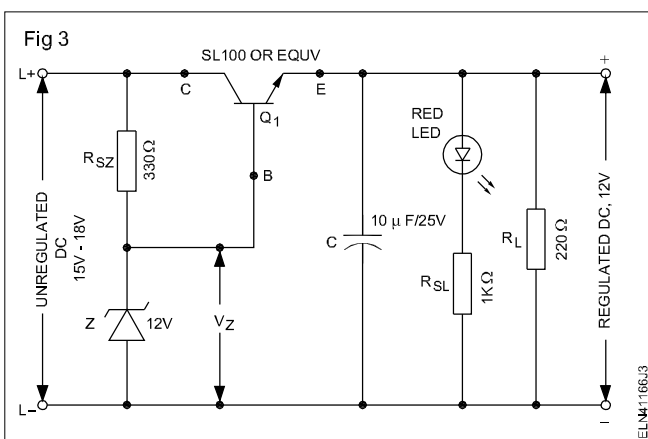

- Measure and record the input voltage and output voltage of the series regulator.
- Measure and record the following voltage levels in observation and tabulation sheet .
 - Voltage across zener, V_z
 - V_{CE} of the transistor Q_1
 - V_{BE} of the transistor Q_1 .
- Keep input P.S Voltage 2V and measure O/P voltage and record in Table 2.
- Increase the voltage steps of two and record the corresponding O/P voltage in Table 2.
- Increase the voltage steps up to 16V and record.

Beyond 12V in the output voltage, any increase in input voltage beyond 12V, 14V or 16V will not make any change in output voltage.

- Connect an unregulated DC voltage of 0 - 30V to the input terminals of the wired series regulator board.
- Get the interconnections made checked by your instructor.
- Switch on the AC mains supply to the unregulated dc supply.

- Switch 'OFF' & Connect to the CRO to the I/P side and O/P side of P.S. (using dual trace CRO) measure and record the ripple presentation the circuit. Record it in Table 2.
- Calculate the ripple factor in Table 2.

Fig 4

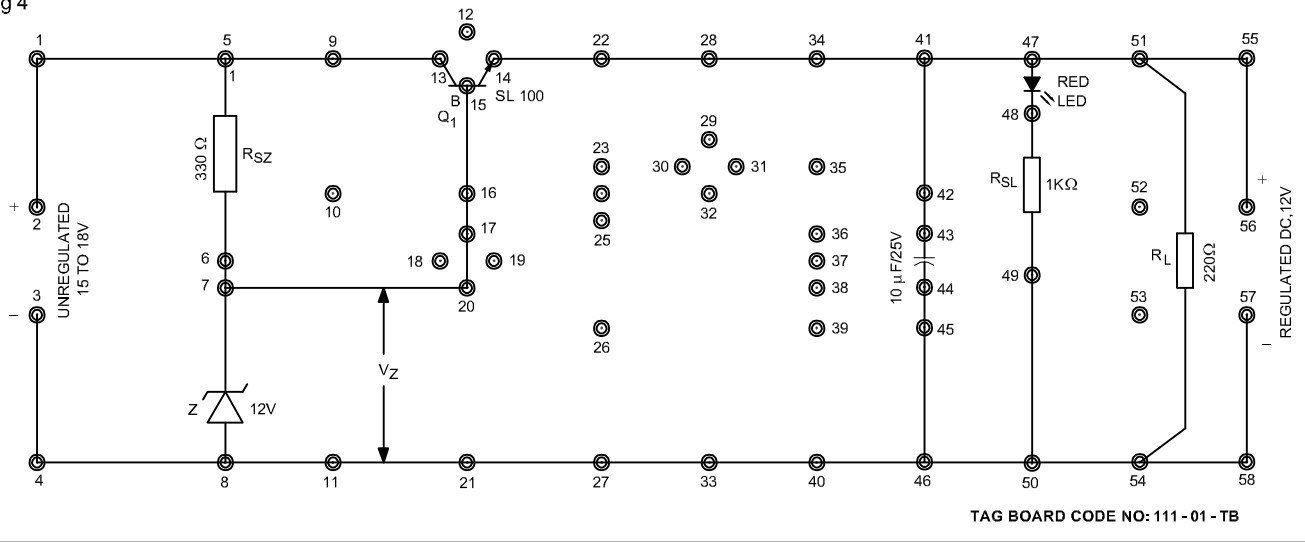

Ripple factor in %

- Calculated _____
- Original _____

Operate and set the required frequency using function generator

Objectives : At the end of this exercise you shall be able to

- identify the various controls of the function generator
- operate the equipment and set the required frequency and wave form
- measure the time and frequency of the set waveform using CRO.

Requirements			
Tools/Instruments		Materials	
• 10 MHz oscilloscope dual Trace	- 1 No.	• Patch cords	- 1 Set.
• Function generator	- 1 No.		
• AF oscillator 20 kHz	- 1 No.		

PROCEDURE

TASK 1: Practice using of a function generator

- 1 Locate the various control of the function generator on its front panel which may look like Fig 1. (Some other model have few changes)
- 2 Keep the amplitude adjustment knob to a minimum position.

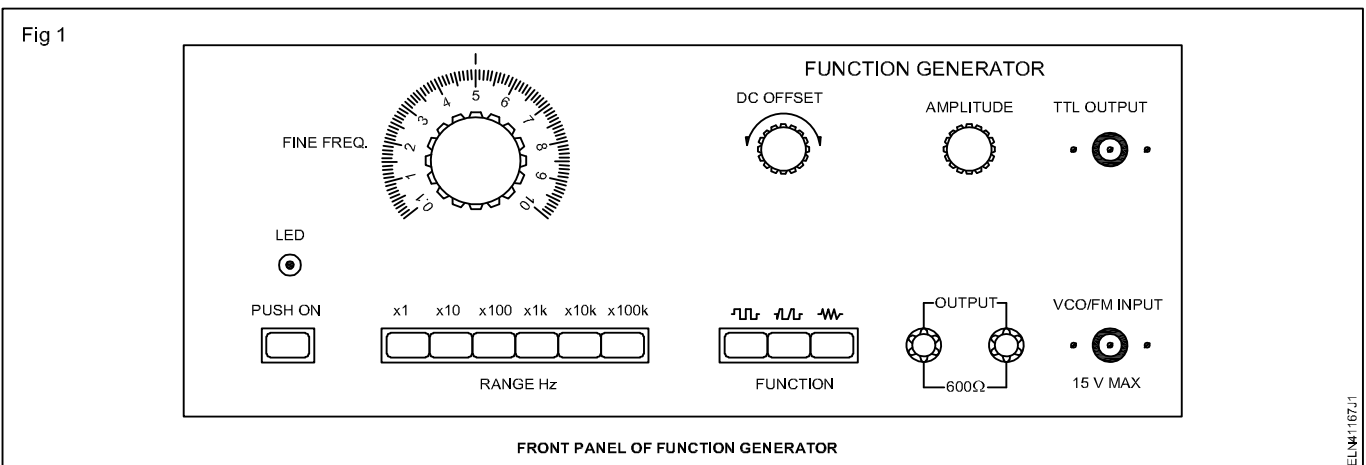

- 3 Connect B & C cable to CRO and set CRO working/measuring conditions.
- 4 Using patch cords connect the output terminals of the function generator to the input terminals of the CRO. Keep both the instruments in OFF position.
- 5 Press the function switch to select sine wave.
- 6 Select 10 Kilo Hertz Range by pressing the range switch marked 'X 10 K'
- 7 Keep the fine frequency dial to position 2 (Fig 1).
- 8 Set AC-DC switch to AC position (out) in the CRO.
- 9 Switch 'ON' the power of both function generator and the CRO. Adjust the trace to be on the centre of the screen.
- 10 Adjust the amplitude knob of the function generator and the Volts/DIV on the CRO To get a clear sine wave on the screen follow the illustration (Fig 2).

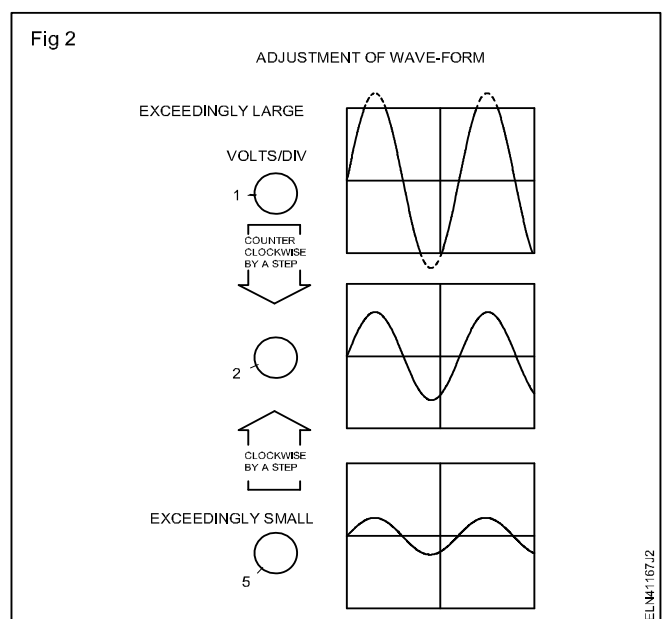

11 Adjust the TIME/DIVISION knob to get adequate number of peaks on the screen.

Relationship between TIME/DIV. (sweep time) and No. of peaks.

When the TIME/DIV. switch is turned clockwise, the time per one period of saw-tooth wave will become small and the wave-form part is stretched. (Fig 3)

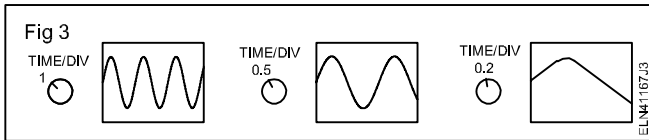

12 Adjust the X-shift control to move the start of the measurement period to a convenient reference point (intersecting point of vertical and horizontal lines). (Fig 4)

13 Check the time period of the wave form. The time between a and b can be determined by counting the no. of horizontal divisions and multiplying it with time base range.

Example

If the time base is set to 0.01 millisecond. There are 5 divisions between 'a' and 'b'.

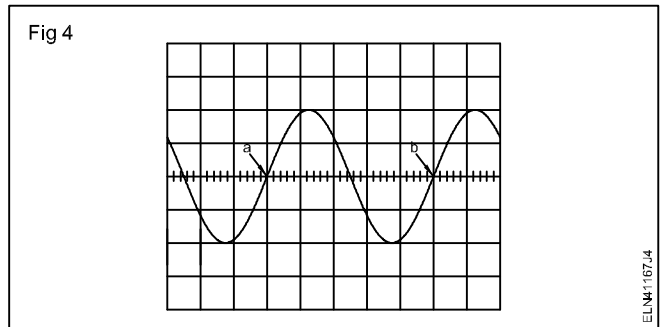

therefore time period $t = 5 \times 0.01 = 0.05 \text{ ms}$

therefore frequency of the wave form

$$f = \frac{1}{t} = \frac{1}{0.05 \times 10^{-3}} = 20 \text{ kHz.}$$

14 Vary the frequency range settings on the functions generator (follow the Table.1) and verify the output frequency using oscilloscope.

15 Set the function switch to some other wave (e.g. square, triangular etc..) and repeat the steps 9 to 13 (Note to record the readings in Table 1). Only sine wave entry is needed in Table 1.

Table 1

Trial No.	Range switch position	Fine freq. dial position	Set frequency	Measured frequency using CRO	Remarks
1	x 1	10	10 Hz	—	
2	x 10	5	50 Hz	—	
3	x 100	3.5	350 Hz	—	
4	x 1K	5	5 kHz	—	
5	x 10K	0.1	1 kHz	—	
6	x 100K	2	200 kHz	—	

TASK 2 : Practice using a AF oscillator

Most of the AF oscillators produce sine wave only. In certain AF oscillator, there will be a provision for square wave in addition to sine wave.

1 Follow the procedure out lined in Task 1 to measure the output frequency of a AF generator (oscillator) and enter the reading in Table 2 for the given settings.

Table2

Trial No.	Range switch position	Fine frequency dial position	Set frequency	Measured frequency using CRO	Remarks
1	x 10	1	10 Hz	—	
2	x 10	5	50 Hz	—	
3	x 100	3.5	350 Hz	—	
4	x 1K	5	5 kHz	—	
5	x 10K	0.1	1 kHz	—	
6	x 100K	2	200 kHz	—	

Make a printed circuit board for power supply

Objectives: At the end of this exercise you shall be able to

- transfer the layout on to a copper clad board
- punch component mounting holes
- paint the pattern using etch-resist ink pen, Indian ink or enamel paint
- etch a painted copper clad board
- trace the component side pattern and make the components
- drill holes on the PCB
- rivet tags/terminals at input and output points.

Requirements

Tools/Equipments/Instruments

- Centre punch, sharp tip - 1 No./batch
- Wooden mallet - 1 No./batch
- Trainee's Kit - 1 No./each
- Hand drill/Push-type drill gun - 1 No./batch
- Drill bit, 0.8 m - 1 No./batch
- Drill bit, 2 mm - 1 No./batch
- Bench vice/Table vice - 1 No./batch
- Wooden block (of PCB size) - 1 No./batch
- Glass rod, 30 cm long - 1 No./batch

Materials/Components

- Detergent soap powder - 10 gms.
- White cotton cloth - 1/4 mt.
- Carbon paper, A4 size - 1 No.
- Adhesive tape - as reqd.
- Etch-resist ink pen, black or Indian ink & fine brush No.6 - 1 No.

- Copper clad, 1 oz, 75 x 60 mm (Phenolic) single side - 1 No.
- Copper clad board - as reqd.
- FeCl₃ in liquid or powder form - 50 ml.
- Detergent soap powder - 10 gm.
- Thinner/Alcohol/Petrol - 100 ml.
- Post-type termination tags, riveting type - 4 Nos.
- Turret type termination tags, riveting type - 2 Nos.
- Carbon paper, A4 size - 1 No.
- Plastic tray, 30 cm x 15 cm aprox. - 1 No.
- Plastic hand gloves - 1 pair
- Glass rod, 30 cm - 1 No.
- Plastic table spoon, 10 ml - 1 No.
- Painting brush, fine, No. 6 - 1 No.
- Permanent marker, blue, fine tip - 1 No.

PROCEDURE

TASK 1: Prepare the tracks on copper clad board

- 1 Clean the copper side of the 75 mm x 60 mm single side copper clad board using soap and water. Dry it using a piece of cloth.

Presence of oil or dust on the clad hinders transferring of the layout on the board.

- 2 Take a fresh carbon paper of 85 x 70mm and fix it on the copper clad board. (Fig 1)
- 3 Take out the PCB circuit pattern diagram of power supply, prepared for making power supply.
- 4 Fix the circuit pattern over the carbon paper (fixed on the copper clad board at step-2) as in Fig 2. Get it checked by your instructor.

Use adhesive tapes at several places such that the layout drawing sheet does not slip off while tracing.

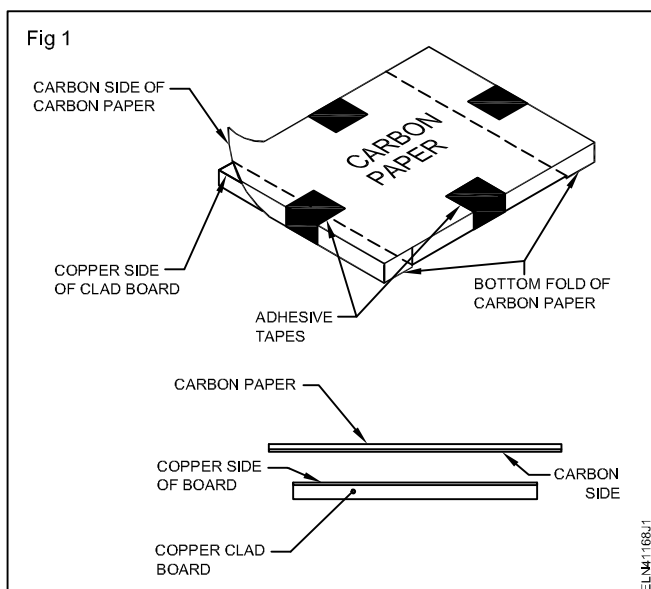

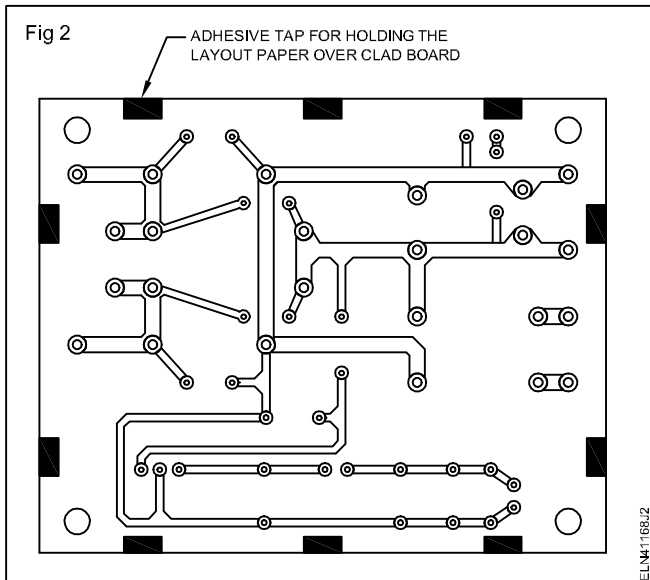

- 5 Make punch marks using a centre punch, at the centres of all inner circles and the mounting hole circles.

The punching is only to make a mark on the copper clad and not to make a hole on the clad. So, do not hit very hard.

- 6 Trace all the pads and connecting tracks using a 2H pencil.

Do not use excessive force while tracing, as this may tear off both the layout and carbon paper. At the same time, do not trace with very little force as this may not transfer the pattern on the copper clad.

- 7 Take out both the circuit pattern diagram sheet and the carbon paper fixed on the clad.
- 8 Check if the all traced impression of the pattern on the copper clad is clearly visible. If not touch up using a sharp tip 2B pencil such that the impression is clearly visible.

- 9 Using etch-resist ink pen or a fine painting brush and Indian ink/ enamel paint, ink the pattern as in Fig 3.

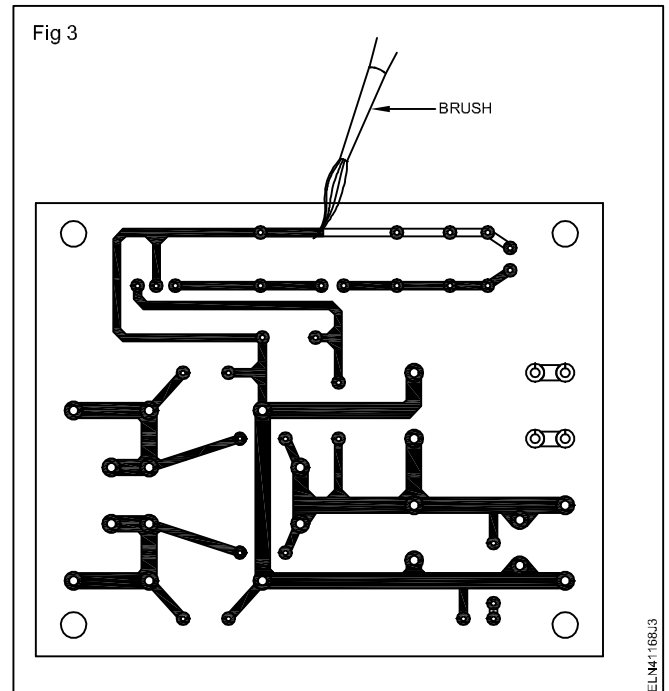

If the ink flows slightly beyond the traced pattern circles and lines, do not try to correct it.

- 10 Allow the ink to dry for 5 to 10 minutes.
- 11 Correct the excessive paint flows outside the intended pattern by using a sharp tip knife or half shaving blade. Allow the pattern to dry up in sunlight for atleast 3 to 4 hours.

The drying period depends on the ink/paint used. Consult your instructor.

- 12 Get your work checked by your instructor.

TASK 2: Etch the painted laminate board and drill holes on PCB

- 1 Take about half litre of luke warm water in a plastic tray of approximately 30 cm x 15 cm.

Do not take an excessively large tray as you may have to make large quantity of etching solution which has to be thrown once the etching is completed.

- 2 Put on hand gloves. Add three spoonful of FeCl_3 etchant to water and stir the solution using a glass rod.

FeCl_3 solution is injurious to bare skin.

- 3 Slide the painted copper clad board PCB-1 (made in Task 1) into FeCl_3 and water solution with the copper clad side facing upward and visible. (Fig 4)
- 4 Move the tray up and down, left and right (Fig 5) such that the solution is agitated adequately in increasing the etching process.

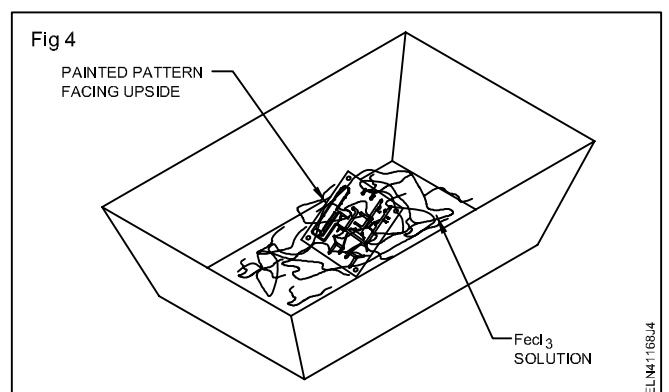

Do not agitate the solution very fast as this may sometimes peel off the paint and etch the required patterns also.

Fig 5

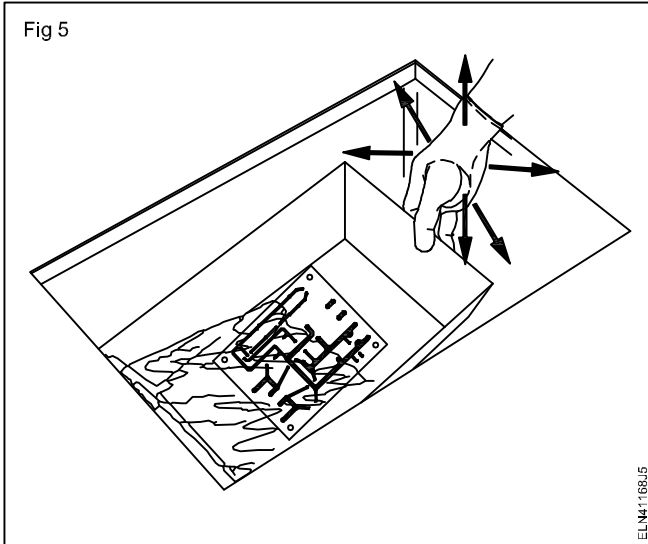

- 5 Repeat step 4 for 10-15 minutes and observe the unpainted portion of the copper clad getting etched OFF.

Once the etching is complete the unpainted portion of the board looks brown or the colour of the board.

- 6 Take out the board from the $FeCl_3$ solution and check visually if the unpainted copper is completely etched. If not, put the board back into solution and allow the board to remain in the solution for 5-10 minutes.

Depending on the concentration of the $FeCl_3$ solution, the etching time may vary from 10 to 30 minutes.

- 7 Take out the board from the $FeCl_3$ solution and wash the board thoroughly in running water.
- 8 Apply a small quantity of detergent powder and wash it again in running water.
- 9 Allow the board to dry in open air or by placing it in front of a fan.

TASK 3 : Trace and mark Component layout on PCB

- 1 Cut the component layout diagram for PCB-1 at its marked border line.
- 2 Fix a carbon paper on the non-pattern side of PCB-1 with the carbon facing the board.
- 3 Take the component side layout diagram of PCB-1 and fix the component layout pattern on the non-pattern side of the PCB. (Fig 7)

Check alignment of holes using a ball pen or poker.

- 4 Trace the pad points and component by using a 2H pencil.
- 5 Remove both papers from the board. If necessary, touch up the tracing using 2B pencil.
- 6 Retrace the component symbols by using a thin tip permanent marker pen and values on the component side of PCB. Allow it to dry for a few minutes.

- 10 Using a thick brush apply thinner or alcohol or petrol on the painted side of the board and remove the ink using a dry cloth.
- 11 Repeat step 10 till the paint is completely removed and the copper pattern is clearly visible.
- 12 Wash the printed circuit board with water and dry it using a piece of cloth.
- 13 Fix the board with a wooden block on a vice as shown in Fig 6.
- 14 Using a hand-drill/push-drill-gun fitted with a 0.8 mm drill bit, drill holes at the punched points at the centre of circular patterns.

Fig 6

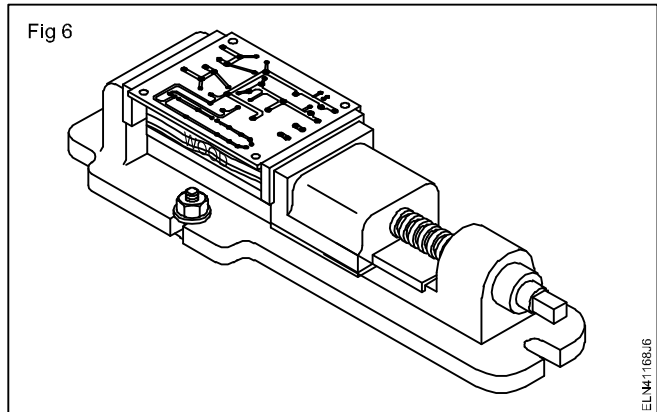

Drill slowly and steadily. Careless drilling may pull the complete circular copper pattern away.

- 15 Drill holes at the corner mounting points by use a drill bit of 2 mm.
- 16 Clean the drilled board from burn and other dirt using cloth or a brush.
- 17 Get your work checked by your instructor.

Fig 7

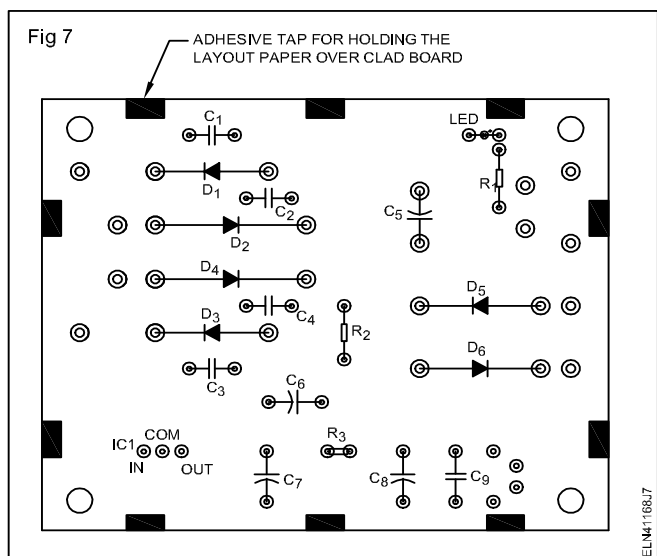

- 7 Rivet 2 number of 2mm post type terminals tags at the AC input 2 numbers at battery input terminals and 4 numbers of turret type terminal tags at the output points marked on the PCB.
- 8 Solder the riveted tags on the solder side of PCB to ensure good electrical joint.
- 9 Get your work checked by your instructor.

— — — — — — — —

Construct simple circuits containing UJT for triggering and FET as an amplifier

Objectives: At the end of this exercise you shall be able to

- construct UJT relaxation oscillator for triggering and test
- identify the terminals with specification of JFET and test a N-channel JFET
- construct an AC voltage amplifier using JFET and find the gain
- plot the graph of gain of the amplifier at different frequencies.

Requirements

Tools/Equipments/Instruments

- Trainee tool kit - 1 No.
- Dual channel oscilloscope 20 MHz - 1 No.
- Power supply unit 0-30V 2A variable - 1 No.
- Function generator 2 to 200Hz - 1 No.

Materials/Components

- General purpose PCB (4 x 8)cm - 1 No.
- UJT 2N2646 - 1 No.
- Carbon resistors - 1/4 watt
 - 47Ω - 1 No.
 - 470Ω - 1 No.
 - 2.2 KΩ - 1 No.
- Potentiometer 1/2 w, 470 KΩ - 1 No.

- Capacitor 0.02 μf, 25V - 1 No.
- Hookup wires - as reqd.
- Solder - as reqd.
- Assorted types of N-channel, JFET (JFET - BF 245 B/BFW 10) - 4 Nos.
- Sleeves - Red, Green, Yellow, Black (2 cm length each) - 4 Nos.
- Capacitors : 5.6 ηF -Disc type - 1 No.
- 270 ηF - 1 No.
- 6.8 μF/24V electrolyte - 1 No.
- Resistors - Carbon Film - 1/4 W
 - 1MΩ, 47KΩ, 10KΩ - 1 No.

PROCEDURE

TASK 1: Construct UJT relaxation oscillator for triggering and test it

- 1 Assemble the relaxation oscillator on the general purpose PCB by referring the circuit diagram (Fig 1)

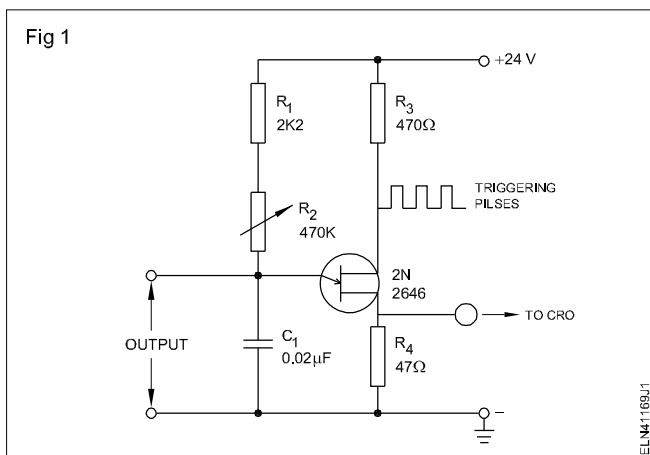

- 2 Get the wired oscillator checked by your instructor.
- 3 Energise the circuit with the stipulated DC.

- 4 Check the triggering pulses by using CRO between emitter and base and sketch these wave forms in Table 1.

- 5 Calculate the frequency from the reading taken at Table 1 and apply formulae given below. Keep the potentiometer at minimum, maximum and middle position, record the details of wave forms on Table 1.

Frequency = $1/t$ where 't' is the time period in seconds.

Time period (Condition 1) $t =$ when $C = 0.02 \mu\text{FD}$ and R_2 is at one extreme end ($R_2 = 0$)

Time seconds = $(R_1 + R_2) \times C$

where R_1 & R_2 are in ohms

C in Farad

$R_1 = 2K2$ ohms and $R_2 = 470 K$ ohms variable

Value of R_2 at middle = $235 K$ ohms

R_2 at other end = $470 K$ ohms

- 6 Get the work checked by your instructor.

Table 1

SI. No.	Waveform at the output terminals	Amplitude	't' time period	Frequency
1	POT at one extreme end			
2	POT at middle position			
3	POT at other extreme end			

- - - - -

TASK 2 : Identify the leads of given JFET's and find specifications of JFET using data manual and testing of N - Channel JFET

- Take a JFET from the given assorted lot. Record the Type number of the JFET and enter it against its label number in Table 2.
 - Maximum power dissipation, P_{max}
 - Package type
 - Pin diagram
- Referring to data manual, identify and record the following important specification of the JFET based on its Type Number;
 - Polarity of the device(N-type/P-type)
 - Maximum drain-source voltage, V_{DS}
 - Maximum gate-source voltage, V_{GS}
 - Maximum drain current, I_D
 - Maximum forward gate current, I_G
 - Pinch-off Voltage(at $I_D=0$), V_P
- Identify the leads of the JFET from the identified package type, and put sleeves of suitable length to the leads following the colour scheme given below;
 - Drain - Red
 - Source - Green
 - Gate - Yellow
 - Shield - Black
- Repeat steps 1 to 3 for the remaining JFETS.
- Get the work checked by your instructor.

Table 2

FET No.	Type	Polarity	V_{DS}	V_{GS}	I_D	I_G	V_P	P_{max}	Pin diagram

- Identify the internal polarity of the terminals of the ohmmeter/multimeter and insert the red probe to the meter terminal connected to +ve of internal battery and black probe to -ve of the internal battery by referring Chart 1.
- Set the meter to Rx1000 range. Refer table given below and test the given JFET. Record the readings taken for each JFET in Table 3.

Chart 1

	GATE	SOURCE	DRAIN	Measured Resistance	
				GOOD FET	BAD FET
1	OPEN	- Ve	+ Ve	Very Low	High/VH
2	OPEN	+ Ve	- Ve	Very Low	High/VH
3	- Ve	OPEN	+ Ve	Very High	Low/VL
4	+ Ve	OPEN	- Ve	Very Low	High
5	- Ve	+ Ve	OPEN	High	Low
6	+ Ve	- Ve	OPEN	Low	High

8 From the recorded resistance readings in Table 3, give your conclusion on the condition of the JFET. (Refer Table 2)

9 Repeat the steps 2 and 3 for the remaining N-channel JFET's.

10 Get the work checked by your instructor.

Table 3

FET No.	Gate	Source	Drain	Measured resistance	Condition good/bad
	open	-ve	+ve		
	open	+ve	-ve		
	-ve	open	+ve		
	+ve	open	-ve		
	-ve	+ve	open		
	+ve	-ve	open		

TASK 3 : Construct and test an AC/FET amplifier and plot the graph

1 Refer Fig 2 and construct an AC voltage amplifier using a N-channel FET.

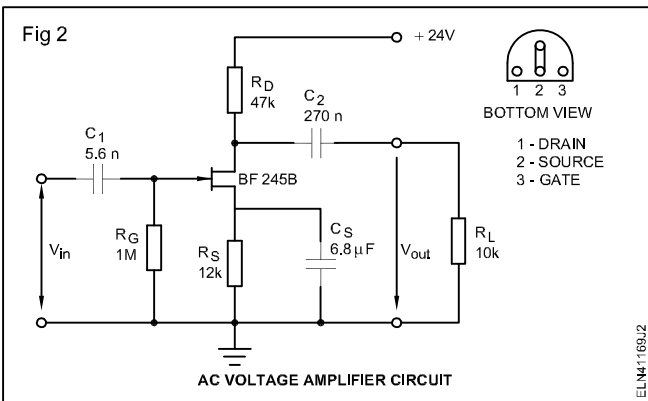

Construct the circuit on a bread board or on a GPCB. If you are wiring the circuit on a GPCB use base for the FET to ensure that it does not get damaged.

- 2 Get the wired circuit checked by your instructor.
- 3 Power ON wired circuit. Feed input, at 10 kHz and level from 1mV to 1V in steps of 100mV. Measure the corresponding output levels by using CRO and record in Table 4.
- 4 From the recorded readings at step 3, calculate and record gain of the amplifier.
- 5 Get the recorded readings checked by your instructor.
- 6 Calculate the gain of the amplifier with an input of 400 mV at frequencies 40 KHz, 80 KHz, 100 KHz, 120 KHz and at 150 KHz in Table 5.
- 7 Get the work checked by your instructor.

Table 4

Input frequency : 10 KHZ			Gain = $\frac{\text{Output voltage}}{\text{Input voltage}}$
Sl. No.	Input voltage	Output voltage	
1	100 mV		
2	200 mV		
3	300 mV		
4	400 mV		
5	500 mV		
6	600 mV		
7	700 mV		
8	800 mV		
9	900 mV		
10	1V		

Table 5

Input volt	Gain = $\frac{\text{Output voltage}}{\text{Input voltage}}$
Frequency kHz	
40	
80	
100	
120	
150	

8 Plot the graph input/output voltage vs gain as in the first case and frequency vs gain in the second case.

9 Get the graph approved by instructor.

Troubleshoot defects in simple power supplies

Objectives: At the end of this exercise you shall be able to

- carry out step-by-step troubleshooting of a power supply having bridge rectifier and capacitor filter
- carry out a short cut method of troubleshooting of the power supply through problem tree and service flow diagram.

Requirements		
Tools/Equipments/Instruments		Materials/Components
<ul style="list-style-type: none"> • Trainees kit 	- 1 No.	<ul style="list-style-type: none"> • Bridge rectifier power supply circuit with filter • Spare components
		- 1 No. - as reqd.

PROCEDURE

TASK 1 : Troubleshoot defects in bridge rectifier power supply

1 In the given power supply board, refer Fig 1. Check for any one of the physical defects listed below; Record the observed defect(s) in Table 1. Service the defect(s).

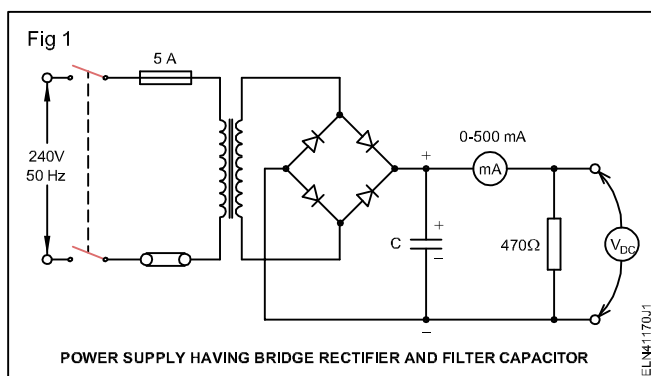

- Loose/open wire connections.
- Loose/open component lead connections.
- Dry solder points.
- Shorting of terminals due to solder spray or bad skinning/bending of wire ends or component leads.

2 Trace the circuit wiring and check the correctness of the following.

- Polarity of diodes
- Polarity of polarized capacitors.

Correct the polarities if found defective and record the defect observed and polarity corrected in Table 1.

3 Open one of the wire ends of the power cord connected to the power supply. (Fig 2)

This will disconnect the transformer primary from the power cord.

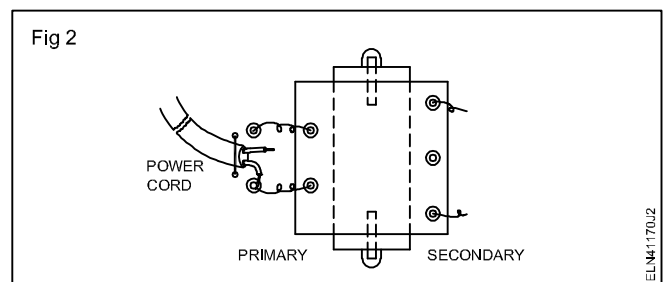

4 Using a continuity tester, check the power cord for any one of the following defects and record the defect observed if any;

- Open or shorted wires in the plug.
- Open or shorted wires in the 2-core cable.

5 Check the continuity of transformer primary winding. If found open or short the coils record defect.

6 Remove the wires soldered at the secondary winding terminals of the transformer (Fig 3). Check the continuity of the secondary windings. Record your observation.

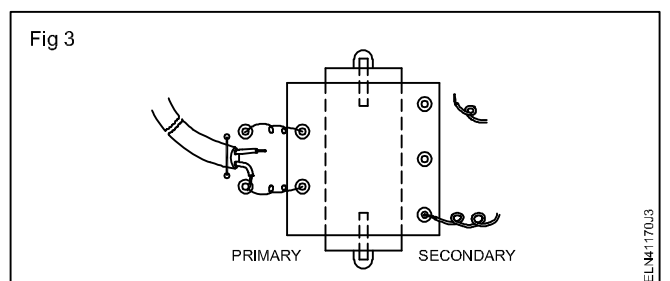

7 Open one lead of each diode (Fig 4). Check the condition of the diodes. Record your observation in Table 1.

Table 1

SI.No.	Name of the defective component	Nature of defect observed	Specification the component to be replaced	Equivalents, if any, for the components to be replaced	Specification of the component to be replaced
Sample	Soldered point	Dry solder	De-soldered

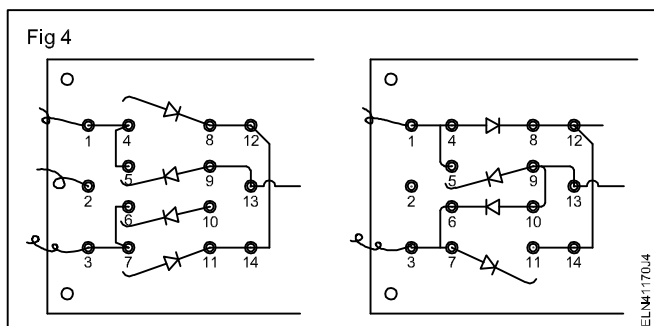

- 8 Open one of the leads of the capacitor. Check the condition of the filter capacitor by carrying out the capacitor action test. Record your observation in Table 1.
- 9 Check the condition of the bleeder/load resistor. Record your observations in Table 1.
- 10 Get the defects recorded in steps above, checked by your instructor. Get his approval to replace the components found defective.
- 11 Collect and test the new components to replace the identified defective components.

- 12 Replace the defective components with the new components and solder back all connections opened while testing.
- 13 Connect serviced power supply to AC mains and switch ON mains supply. Check and record the output condition in Table 2 under the heading final condition after servicing.

If there is no output from the PSU even after carrying out the laid procedure of servicing, consult your instructor.

The output may have problems other than the one for which it is serviced. Record the problem as it is observed.

- 14 Get the work checked by your instructor.

Final condition of power supply after servicing

- a) Output voltage level
- b) Ripple voltage $V_{r(p-p)}$ in output DC

TASK 2 : Troubleshoot defects in power supply using shortcut/logical approach method

- 1 Switch 'ON' the given defective power supply unit and record the identified defect in record sheet.
- 2 Refer the problem tree corresponding to the identified defect.
- 3 Refer the service flow sequence (SFS-1) or (SFS-2) depending on the identified defect of power supply. Follow the logical sequence to service the defective power supply.
- 4 Record the identified component defects and remedial measure taken in Table 2 of record sheet.

Refer the problem tree corresponding to the SFS for finding the possible causes of the defects.

Whenever any component is found defective, record its type, cause of defect and other details in the Table 2 of record sheet.

Whenever any component is replaced, record the specification of the replaced component in Table 2 of the record sheet.

Once the servicing as per SFS is complete, record the final condition of the power supply in Table 2 as done in step 13 of Task 1.

- 5 Get your work checked by your instructor.
- 6 Final condition of power supply after servicing.
 - a) Output voltage level :
 - b) Ripple voltage $V_{r(p-p)}$ in output DC :
- 7 Refer service flow chart 1 & 2 and follow the sequence of approach.
- 8 Interpret the problem Tree-Chart 1 & 2 (PTC-1 & PTC -2) and locate the exact fault / repair.

Table 2

Sl. No.	Name of the defective component	Nature of defect observed	Possible cause(s) of the defect	Specification of the component to be replaced	Equivalents, if any, for the components replaced	Specification of the component replaced

Service flow Sequence (SFS-1)

NATURE OF DEFECT : Low output DC

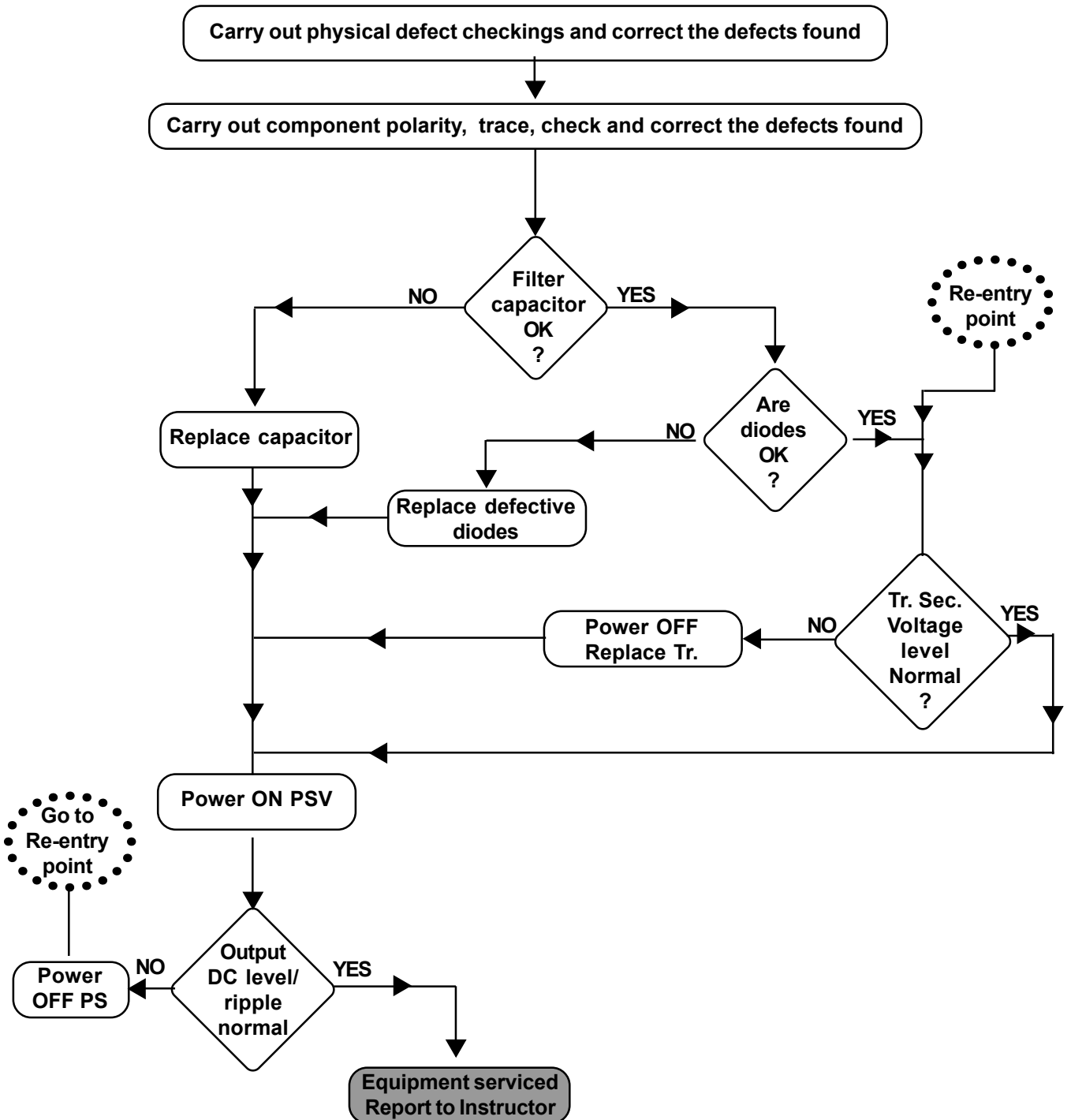

Service Flow Sequence (SFS-2)

NATURE OF DEFECT : Defective power supply with NO OUTPUT VOLTAGE

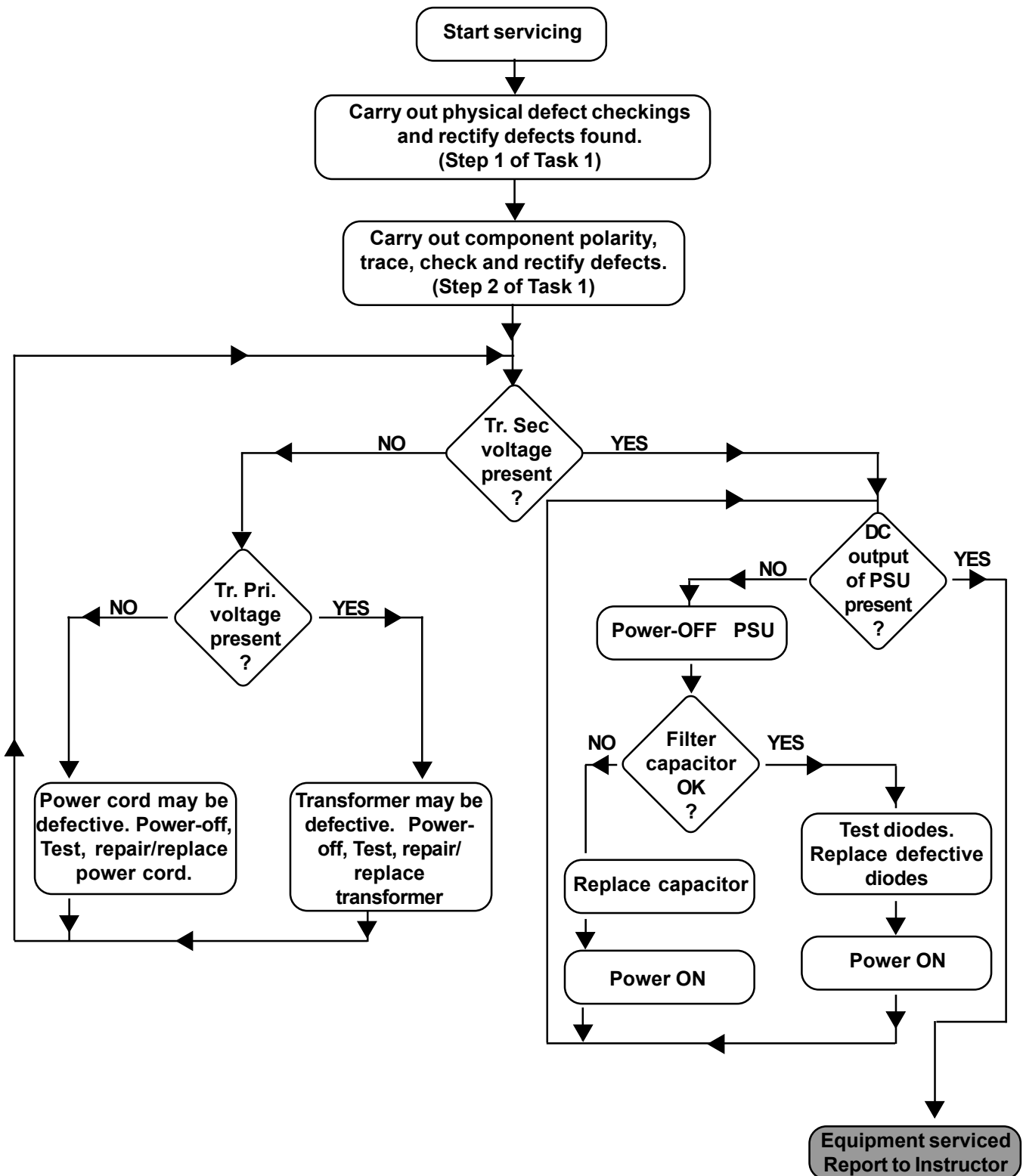

Problem Tree Chart -1 (PTC-1)

NATURE OF DEFECT : **No Output voltage**
 TYPE OF SYSTEM : **Bridge rectifier with capacitor filter**

LEVEL 1

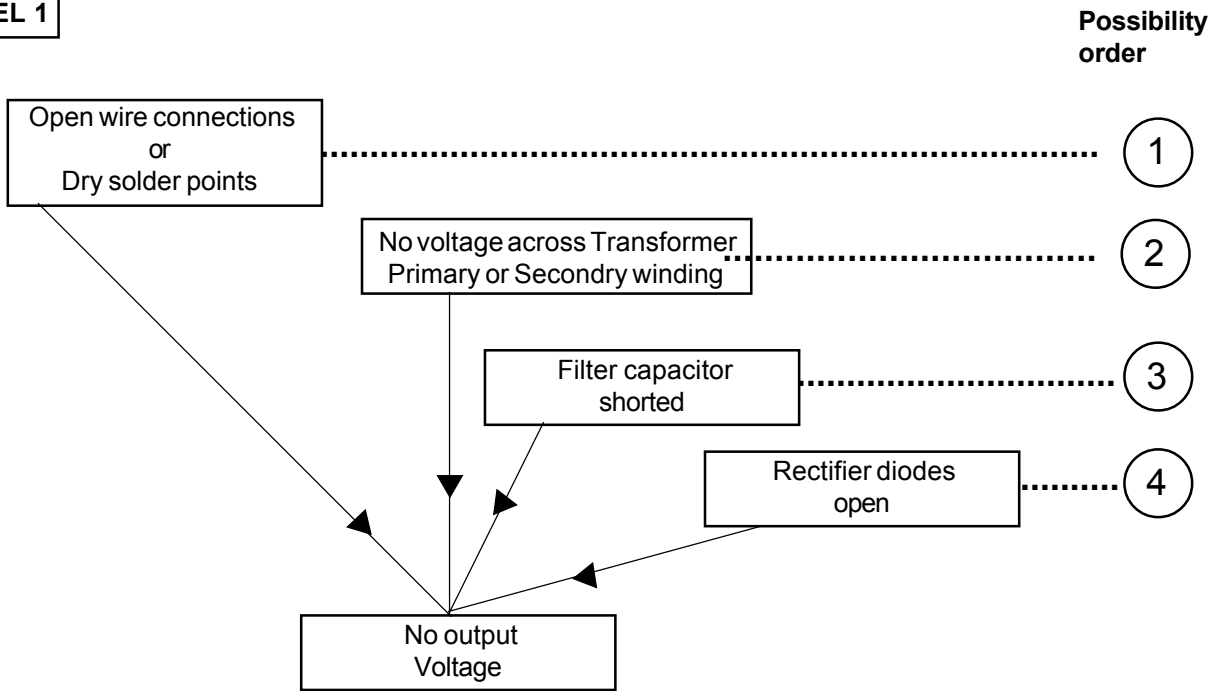

LEVEL 2

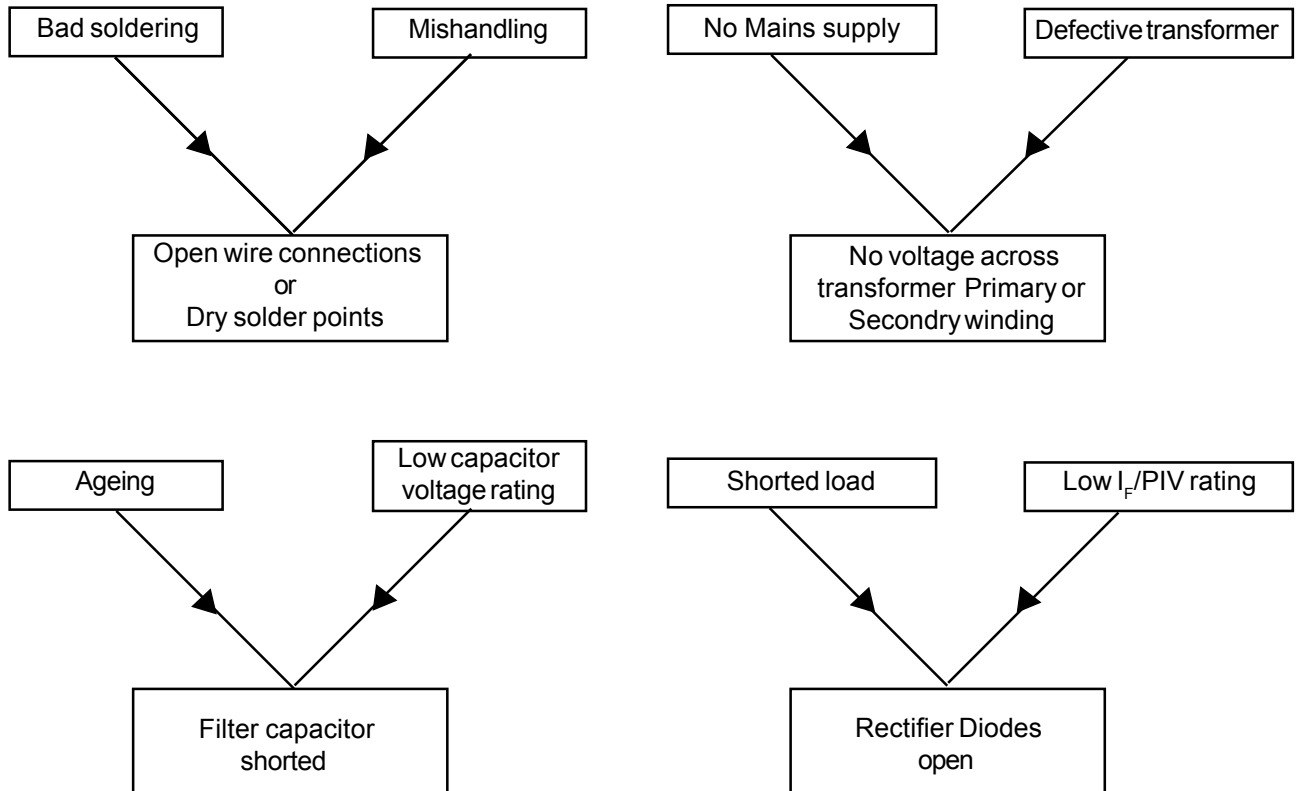

Problem Tree Chart -2 (PTC-2)

NATURE OF DEFECT : **Low Output DC/Increased ripple**
 TYPE OF SYSTEM : **Bridge rectifier with capacitor filter**

LEVEL 1

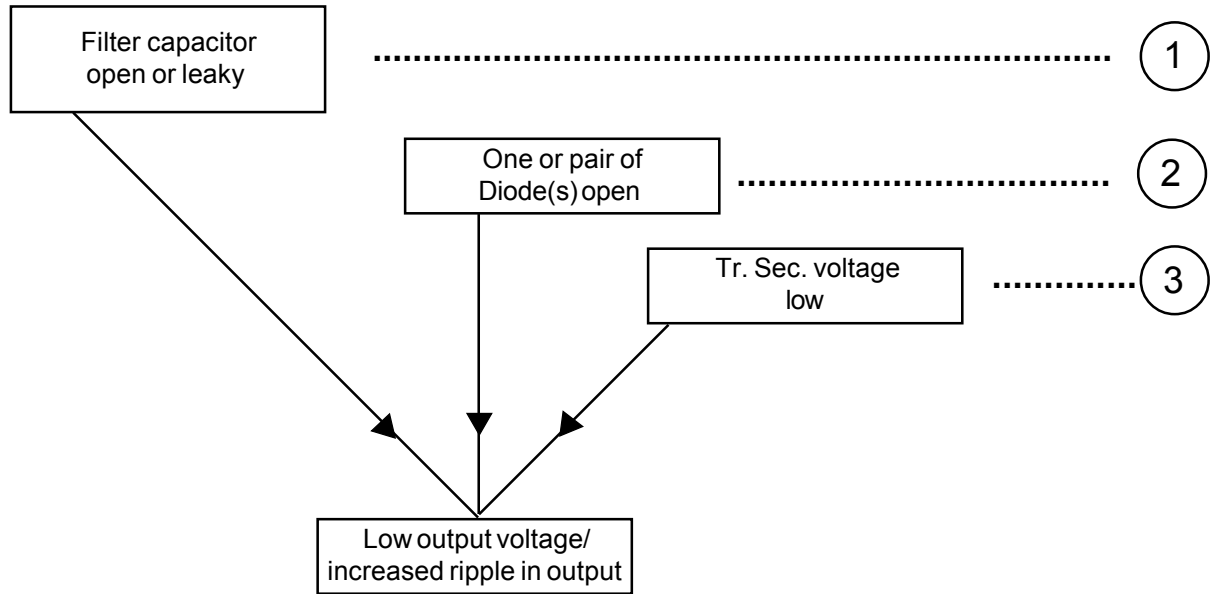

LEVEL 2

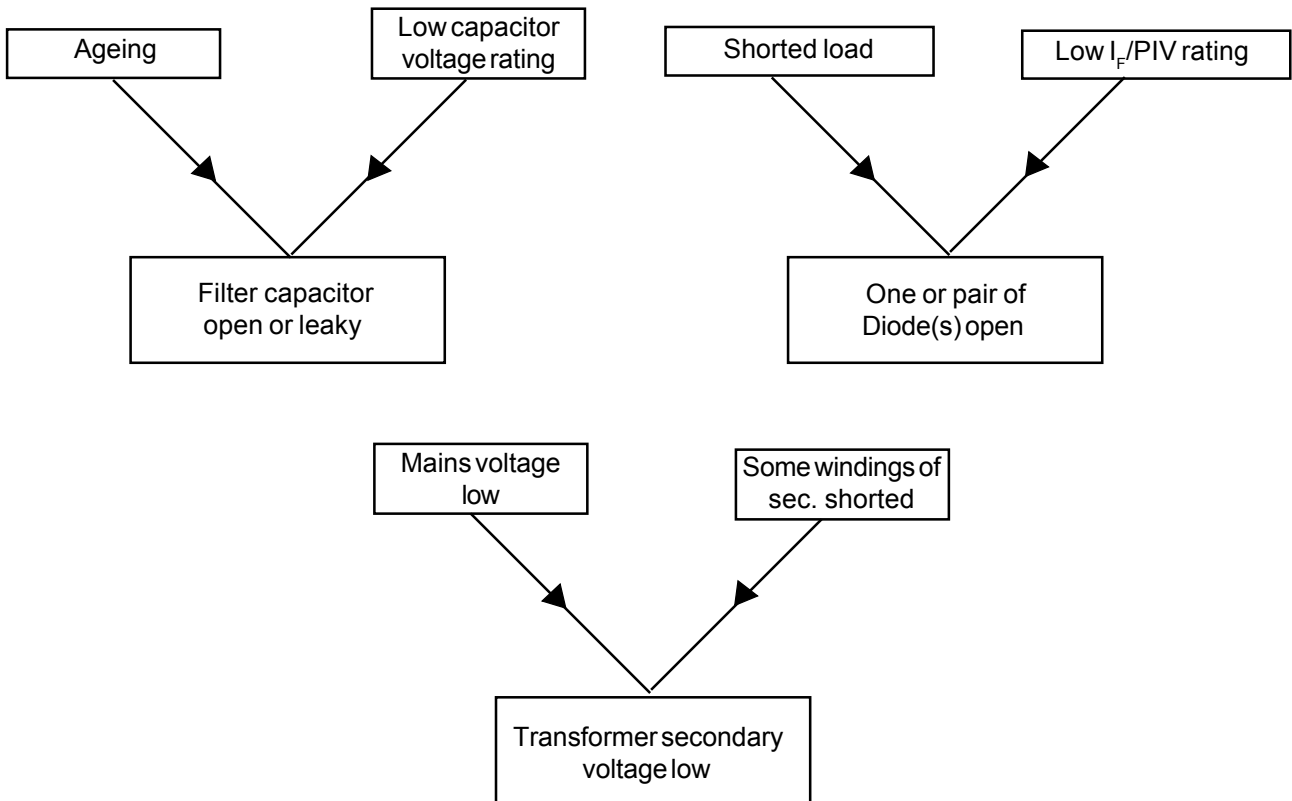

Construct power control circuit by SCR, DIAC, TRIAC and IGBT

Objectives: At the end of this exercise you shall be able to

- assemble and test a lamp dimmer-cum-fan speed regulator using TRIAC and DIAC
- construct and test a power control circuit using SCR
- construct and test a power control circuit using IGBT.

Requirements

Tools/Instruments/Equipments

- | | | | |
|--|---------|--|------------|
| • Soldering iron - 25W/240V | - 1 No. | • Soldering flux (Resin) 60:40 | - as reqd. |
| • Trainees tool kit | - 1 No. | • IGBT - HGTG 12N 60- (pack) | - 1 No. |
| • Lamp load (60 watts 240V) | - 1 No. | • General purpose PCb | - 1 No. |
| • Table fan, 80 watts 240V | - 1 No. | • TRIAC BT 136 or equivalent | - 1 No. |
| • Hand drilling machine with bit (8mm) | - 1 No. | • DIAC D3202 or equivalent | - 1 No. |
| • Universal motor 500W/240V | - 1 No. | • Inductor (25 SWG, 40 turns on 10mm ferrite rod with former made of leatheroid paper) | - 1 No. |

Materials

- | | | | |
|--|------------|-----------------------------------|------------|
| • Triggering pulse module for pulse generator | - 1 No. | • Resistors - 10K, 2W | - 1 No. |
| • Printed circuit board | - 1 No. | 470 Ω | - 1 No. |
| • Resistors | | 1 KΩ | - 2 Nos. |
| – 180 ohms 1w ±5% | - 1 No. | • Pot Meters, 1KΩ, 1W | - 1 No. |
| – 4K7 12 w 5% | - 1 No. | • Capacitors - 2.2 K PF Disc | - 1 No. |
| – 470 K Ohms 1/4w 5% | - 1 No. | 100 PF | |
| • Potentiometer linear 250K, 16 mm plastic shaft | - 1 No. | • SCR - C 106D or equivalent | - 1 No. |
| • Capacitor 0.1 μF 415 Volts | - 4 Nos. | • Transistor - BD 135 | - 1 No. |
| • Solder (Resin) 60:40 | - as reqd. | BD 136 | - 1 No. |
| | | • Diode - 1 N 4007 | - 6 Nos. |
| | | • Connecting cables - 1sq.mm/650V | - as reqd. |

PROCEDURE

TASK 1: Construct power control circuit using TRIAC and DIAC

- 1 Clean the Printed Circuit Board (PCB). Check the circuit components and confirm their working condition.
- 2 Assemble the control circuit referring to the circuit schematic diagram shown in Fig 1a & 1b and PCB layout diagram. (Fig 2)

Use multistrand flexible insulated wire for these connections as these wires will carry A.C mains voltage and large current of the order of a few hundred milliamperes.

- 3 Keep the PCB on any insulated material. Keep the Potentiometer (POT) in mid position. Put AC mains Single Pole Single Throw (SPST) switch mounted on the gang box to 'OFF'.
- 4 Connect a test lamp at the mains output socket (mounted on the gang box).
- 5 Connect AC mains supply to the wired circuit. Put the SPST switch mounted on the gang box to ON. Check if the lamp glows.

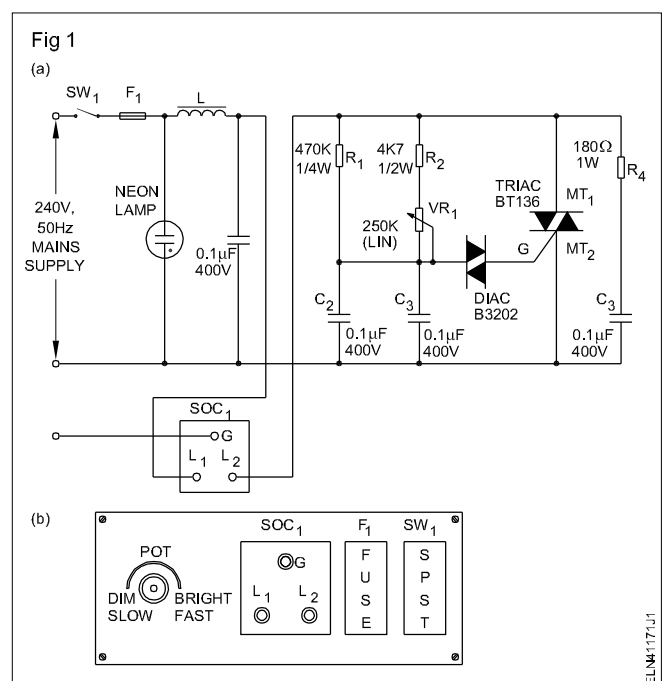

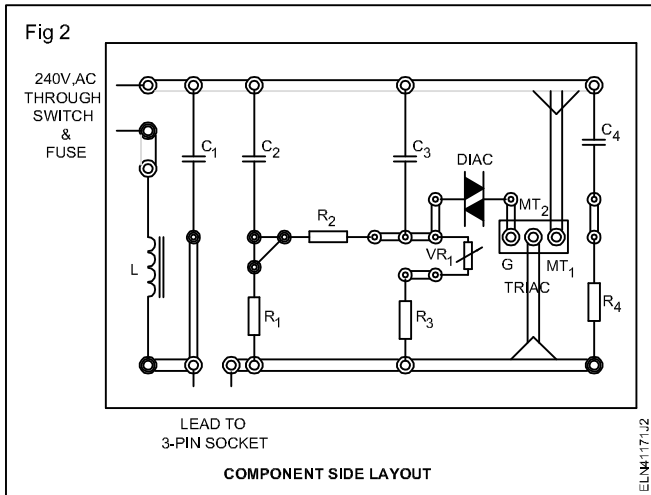

If the lamp is not glowing, switch off mains supply and consult your instructor.

- Vary POT position such that, the light intensity of the output lamp gradually decreases and becomes minimum/zero. Record the status of the lamp intensity at one extreme position of the POT. (Refer Table 1)

Table 1

Status of the lamp intensity when the POT (VR_1) is at one extreme position _____

Light intensity may be recorded as very dim, off or such

- Increase the intensity of lamp gradually by turning the POT from minimum position to maximum position. Check and record the light intensity at other extreme position of the POT. (Refer Table 2)

Table 2

Status of the lamp intensity when the POT VR_1 is at other extreme position _____

Light intensity may be recorded as very dim, off or such

- Repeat steps 6 and 7 a few more times to confirm that the wired lamp dimmer circuit is working satisfactorily. Get it checked by your instructor.
- Remove the lamp load connected at the controlled output of the lamp dimmer circuit. Connect a table fan to the controlled AC output of the wired circuit.
- Switch 'ON' AC mains supply to the circuit. Vary the POT from one end to the other. Observe and record the speed of the fan at minimum, middle and maximum position of the POT.

The Lamp dimmer-cum-fan speed controller is a very versatile and very useful gadget. You can make use of this project constructed for any useful purpose and assembled in a suitable box with all mandatory control and protecting devices.

- Get your work checked by your instructor.

TASK 2: Construct power control circuit using Silicon Controlled Rectifier (SCR)

- Prepare a PCB for the given dimensions (Fig 3). Check the sizes of the components with the soldering position on the PCB. If necessary slightly alter the dimensions of the PCB track.

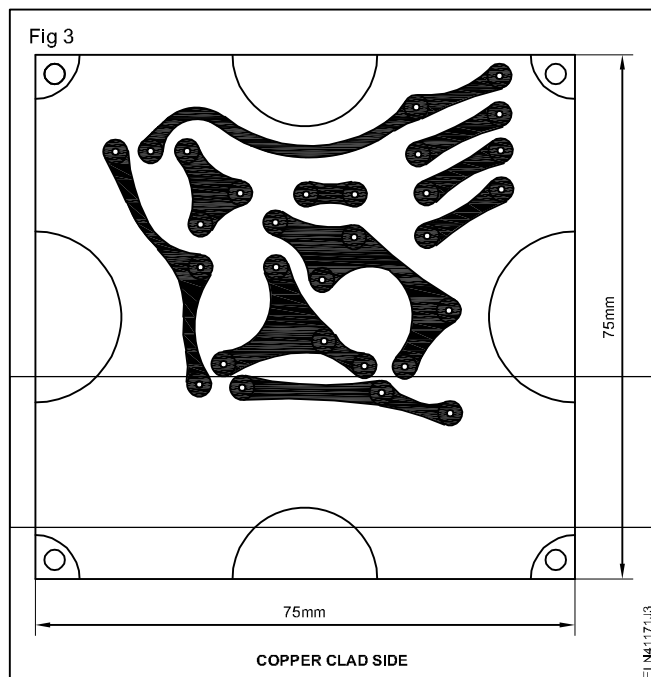

- Check the PCB tracks and clean PCB.
- Test the components to confirm its working condition.
- Wire the power control circuit on the PCB referring to the circuit schematic (Fig 4) and the PCB layout diagram shown in Fig 5. Get the wired circuit checked by your instructor.

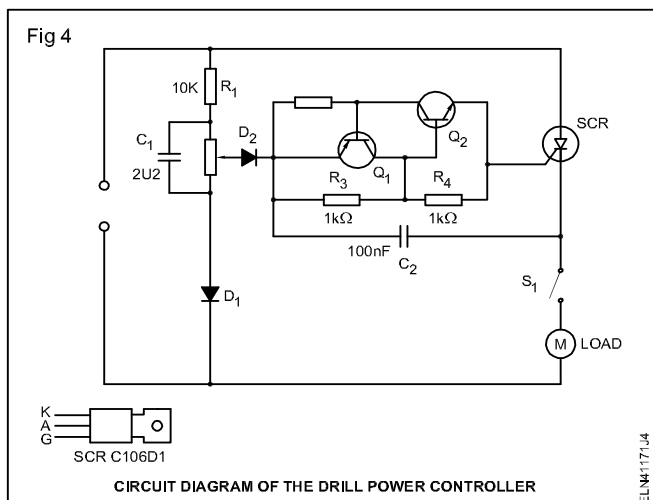

- Using suitable wires make connections for the POT, switch, 6A flush type socket, 3 core cable mains 3-pin top with the wired circuit on PCB. Get the wiring checked by your instructor.

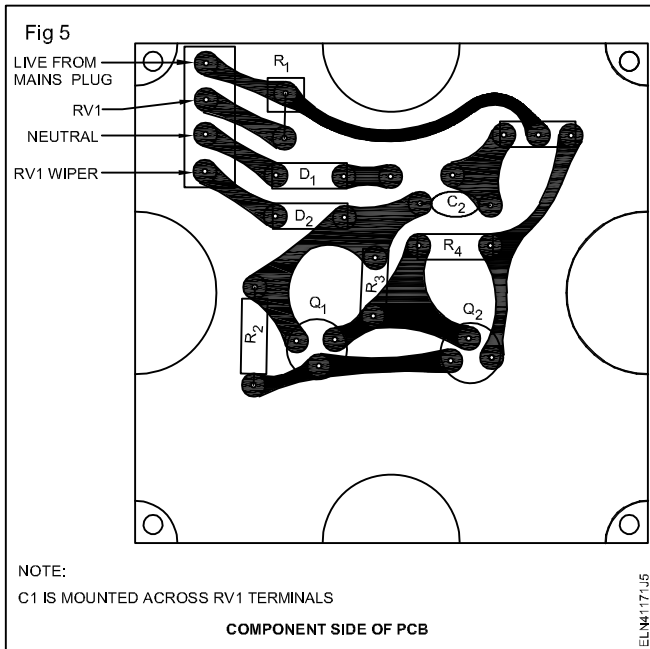

The wire connections made is to test the wired power control circuit. Keep sufficient wire lengths in all connections made for the purpose of safety and ease of testing.

- 6 Test the working of wired circuit by connecting a test lamp load at the output of the speed controller circuit. Find the lamp glow bringing the two extreme positions of the speed.
- 7 Test the speed controller using table fan as load and record your observation.
- 8 Assemble the PCB and other associated items, so that the wired speed controller is ready for use. Get it checked by your instructor.

This wired circuit can be effectively used for a control circuit to use for any speed control purpose. Kept in a box with all mandatory controlling and protecting devices.

- 9 Get your work and recorded readings checked by your instructor.

The wired and tested universal speed controller can be effectively used for any practical applications. So, preserve the project work made and use it whenever required.

TASK 3: Construct power control circuit using Insulated Gate Bipolar Transistor (IGBT)

- 1 Wire the circuit as per the diagram. (Fig 6)

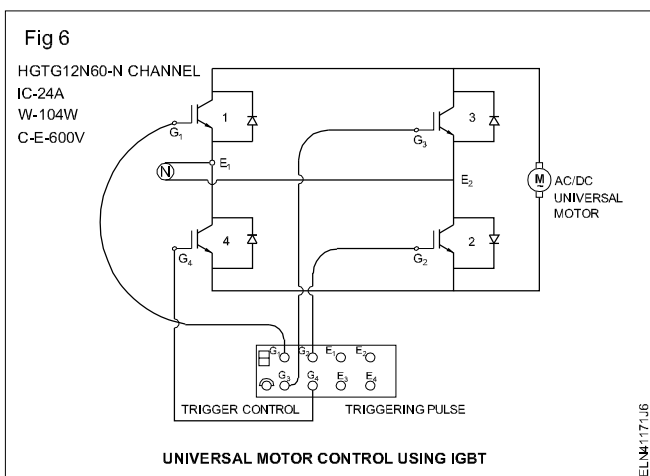

Solder the components on a general purpose PCB and connect the cables for connection.

- 2 Set the input AC single phase supply to 120V and connect to the supply points E₁ & E₂ through a variac.

- 3 Switch 'ON' the triggering pulse generator and set the pulse control minimum position.
- 4 Switch 'ON' the variac.
- 5 Increase the triggering pulse control to rotate the AC/DC motor.

Universal motor rotates slowly with abnormal sound.

- 6 Switch 'OFF' both the control circuit and triggering pulse circuit.
- 7 Set the variac voltage 240V and switch 'ON' the triggering pulse.
- 8 Reduce the speed by controlling trigger control knob. If motor rotates with high speed.

Switch OFF both the circuits. Universal motor not allow to run without load.

Ensure the motor rpm varies as per the variation of trigger pulse control.

- 9 Get it checked with your instructor.

Construct variable DC stabilized power supply using IC

- Objectives:** At the end of this exercise you shall be able to
- construct and test a variable IC regulated power supply
 - test the voltage regulation at various load and ripple rejection.

Requirements

Tools/Equipments/Instruments

- | | | | |
|---------------------------|---------|-------------------------------|---------|
| • Trainees kit | - 1 No. | 10 μ F, 50V, electrolytic | - 1 No. |
| • Soldering iron 25W/250V | - 1 No. | 100 nF, ceramic disc | - 1 No. |
| • Digital multimeter | - 1 No. | • LED, Red | - 1 No. |

Materials

- | | | | | |
|--|----------|--|------------------------------------|------------|
| • General purpose PCB | - 1 No. | • Resistor | 4K7, potentiometer, carbon, rotary | - 1 No. |
| • Step down transformer, 240 V : 24 V or 240 : 12-0-12, 24VA | - 1 No. | • Resistor | 2K2, carbon, 1/2W | - 1 No. |
| • Diodes, 1N4002 or BY127 or equivalent | - 6 Nos. | • Resistor | 220W, carbon, 1/4W | - 1 No. |
| • Capacitors | | • 3-terminal voltage regulator, LM317T, To - 220 package | | - 1 No. |
| 2200 μ F, 50V, electrolytic | - 1 No. | • 1A, slow blow fuse with fuse holder | | - 1 No. |
| 25 μ F, 50V, electrolytic | - 1 No. | • Hook up wires | | - as reqd. |
| | | • Resin cored solder | | - 20 cms. |
| | | • Heat sink for TO-220 package | | - 1 No. |
| | | • Rheostat 100 Ω 1 A | | - 1 No. |

PROCEDURE

- 1 Test all the components to confirm their good working condition. Record the specifications of IC LM317T.
- 2 Check the given general purpose PCB for the following defects and correct them or take a new board;
 - Broken tracks
 - Joined tracks
 - Closed holes
- 3 Clean the copper side of the PCB using alcohol or other cleaning agents. Wash, wipe and dry the PCB.
- 4 Construct a variable regulated output power supply on the given general purpose PCB, referring to the circuit schematic shown in Fig 1.

All components except the transformer to be mounted on GEN-PCB. Use suitable heat sink with IC 317 T.

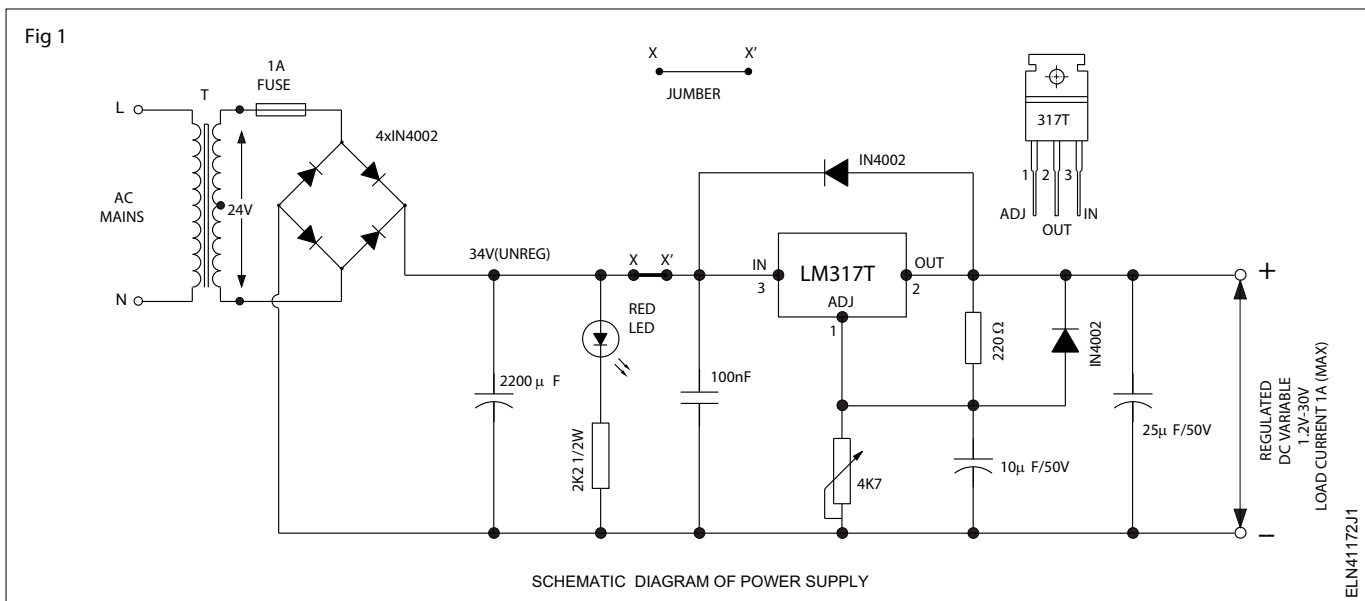

Note : Solder all components except the fuse and transformer on the given PCB

- 5 Get the correctness and neatness of wiring checked by your instructor.
- 6 Connect the secondary of (240:24V) transformer to the wired circuit. Switch ON mains supply.

Switch OFF main supply immediately if burning, smoking overheating, sparks are observed in any of the components, and report to your instructor. Check the IC and ensure that it is not heated-up.

- 7 Measure and record the unregulated dc input and the minimum, maximum variable voltage of the regulator under no-load condition.

- 8 Set the output to +15 volts and load the output using a loading rheostat in steps of 200 mA up to 600 mA. In each step measure and record the output voltage and the ripple voltages.

Load current is restricted to 600mA as heat-sink is provided to the IC may not be the ideal one.

- 9 Calculate and record the output regulation and ripple rejection of the regulator.
- 10 Short the load terminals momentarily by using a DC current meter (0-1A range) and record the short circuit fold back protection current level.
- 11 Get the readings checked by your instructor.

Observation & tabulation sheet

1 Specification of the given 3-terminal regulator IC

Type number	Package type	Output voltage		Max. output current
		Min.	Max.	

- 2 Neatness and correctness of wiring:** Very good Good Satisfactory Poor/Redo Continue Exercise
-

- 3 Unregulated dc input to regulator :** _____
- Minimum adjustable output voltage (No-load) : _____
- Maximum adjustable output voltage (No-load) : _____

4 Set output voltage : 15 volts

Load current	200mA	300mA	400mA	500mA	600mA
Output voltage					
Output ripple (p-p)					
Input ripple					
Output regulation					

- 5 Shorted output current I_{sc} :**
-

Practice on various logics by use of logic gates and circuits

Objectives: At the end of this exercise you shall be able to

- construct an OR gate using lamp and switches and verify its truth table
- construct an OR gate using IC-7432 and verify its truth table
- construct AND gate using lamps and switches
- construct AND gate using IC-7408
- construct NOT gate and verify truth table using transistor.

Requirements

Tools/Equipments/Instruments/Materials

- | | | | |
|--|---------|--|----------|
| • Trainees kit | - 1 No. | • IC base, 14 pin | - 2 Nos. |
| • Regulated DC power supply unit
5V/500mA | - 1 No. | • DC power supply 5V | - 1 No. |
| • DC voltmeter (MC) 0-10V/multimeter | - 1 No. | • SPDT switches
(miniature toggle) | - 2 Nos. |
| • Data Manual | - 1 No. | • General purpose IC
test board/Pin Board | - 1 No. |
| • Digital IC tester | - 1 No. | • Transistor BC 147 | - 1 No. |

Materials/Components

- | | | | |
|---|------------|--------------------------------------|------------|
| • Single pole switch any type/
Toggle switch 240V/6A | - 2 Nos. | • Resistor, carbon film, 1/4w
1KW | - 2 Nos. |
| • Lamp - 250V/100W | - 1 No. | • LED (t5mm)
Green | - 2 Nos. |
| • LED, Red (5mm) | - 2 Nos. | • IC 7404 (Hex inverter) | - 1 No. |
| • ICs
7408 QUAD AND gate | - 1 No. | • IC 4049 (Hex inverter) | - 1 No. |
| 7432 | - 1 No. | • IC base 14-pin | - 2 Nos. |
| • Connecting wires | - as reqd. | • Hookup wire
Red 50cm | - as reqd. |
| • Solder, flux | - as reqd. | Black 50 as reqd.cm | - as reqd. |

PROCEDURE

TASK 1: Construct an OR gate using two switches with lamp and verify its truth table

1 Refer Fig 1 and wire an OR gate circuit on a test board/pin board.

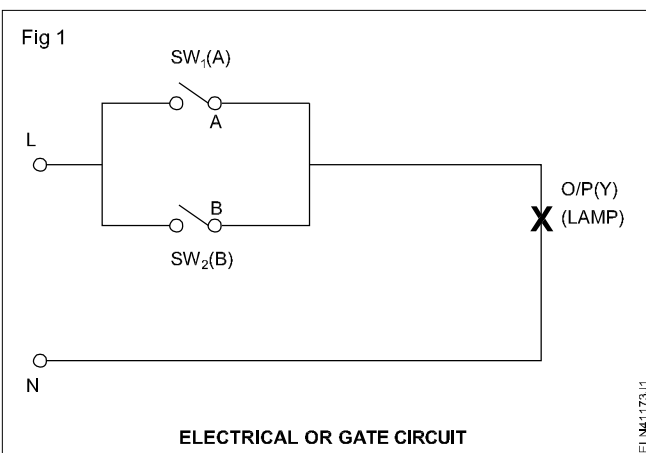

- 2 Apply logic level inputs to A and B of the circuit as given in Table 1. Record the output lamp condition in each case and verify its truth table.
- 3 Get the recorded readings checked by your instructor.

Table 1

Truth table of OR-gate using switches and lamp

Logic input		Logic output
A SW1	B SW2	Y = A + B lamp
0	0	
0	1	
1	0	
1	1	

TASK 2 : Construct a Quad two input OR gate using IC-7432

- 1 Record the details of the given IC-7432 in Table 2 of record sheet referring to data manual.
- 2 Insert the IC-7432 into the IC base of the general purpose IC test board.
- 3 Make other circuit connections to the IC in Fig 2.
- 5 Repeat step 4 for the other three OR gates of the IC.
- 6 Write your conclusion about the condition of each OR gate in Table 3 based on the recorded output of gates.
- 7 Get the recorded readings checked up by your instructor.

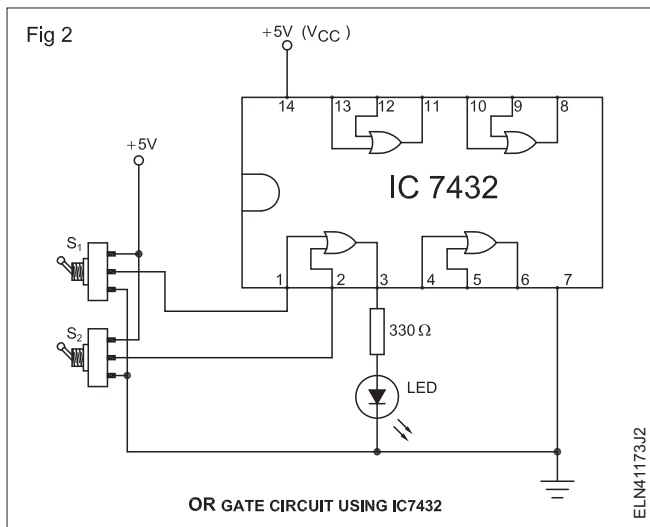

Disconnect connections made at input and output of the gates. Allow the IC 7432 to remain plugged on the board for subsequent tasks.

Table 3

Truth table of OR-gate using IC7432

Logic Input		Output logic at Pin No.			
A	B	3 Gate-1	6 Gate-2	8 Gate-3	11 Gate-4
0	0				
0	1				
1	0				
1	1				

Condition of gate in the IC :

- 4 Set switches SW₁ and SW₂ to apply input logic levels as in Table 3 to the first OR gate (Fig 2). Record the output logic level and verify its truth Table 3.

Table 2

I.C No.	Type of package	Total no. of pins	Input voltage		Output voltage		V _{CC} /V _{DD}		Status	Temperature of IC range
			Logic- 0	Logic- 1	Logic- 0	Logic - 1	max.	min.		
7432										
7402										

TASK 3 : Construct AND gate using two switches with lamp and verify its truth table

- 1 Refer Fig 3 and construct the AND gate circuit using on a board switches and lamp test.
- 2 Get wired circuit checked by your instructor.
- 3 Apply different logic levels to the inputs A & B as given in Table 4 . Record the corresponding output logic level and lamp status.
- 4 Get the work checked by your instructor.

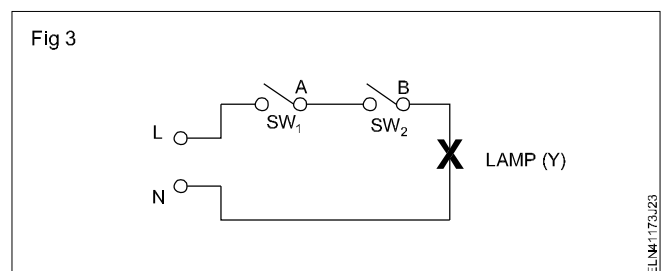

Table 4

Truth table of AND gate using switches and lamp

Input		Output				
Logic level		Equivalent voltage level given as inputs		Logic level	Voltage level	LED status (ON/OFF)
A	B	A	B			
0	0					
0	1					
1	0					
1	1					
open	open					

TASK 4 : Construct and test an AND gate using IC (7408)

- 1 Make circuit connections (Fig 4) using IC 7408 (AND).
- 2 Apply different logic levels to the inputs A and B to gate-1 (between pins 1 & 2) and record output (pin 3).
- 3 Repeat step 2 for the other AND gates in the IC 7408 by suitably modifying the circuit at input & output.
- 4 Conclude the condition of the IC in sheet after verifying truth table at Table 5.
- 5 Get the work checked by your instructor.

Table 5

Truth table of AND gate IC-7408

Input		Output Y = A·B			
Logic level A	B	Y ₁ (pin 3)	Y ₂ (pin 6)	Y ₃ (pin 8)	Y ₄ (pin 11)
0	0				
0	1				
1	0				
1	1				
Condition of gate					

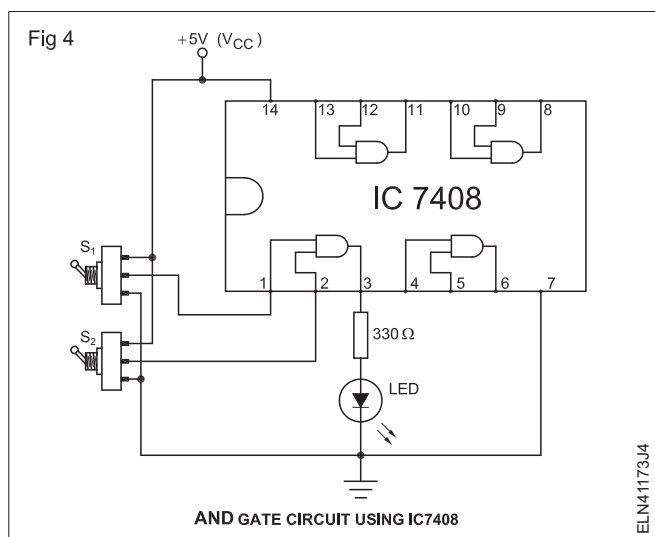

TASK 5 : Construct a NOT gate using discrete components and verify its truth table

- 1 Construct the NOT gate using discrete components as shown in Fig 5 on the general purpose PCB. Get it checked by your instructor.
- 2 Power ON the circuit, by applying 5V Fig 5. Apply logic level-0 to the input (see note below) and record the voltmeter reading, its equivalent logic level and the status of LED.

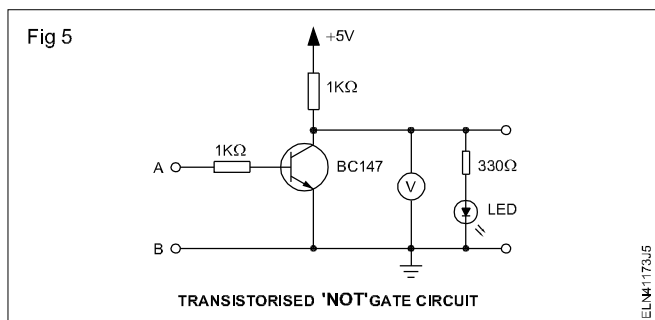

When the input terminal of the circuit is grounded, it is equivalent to applying logic 0. Note that keeping input terminals open is not equal to logic 0 level.

- 3 Apply logic level-1 to the input (see note below) and record the voltmeter reading, its equivalent logic level and the status of LED.

When the input of the circuit is connected to +5V, it is equivalent to applying logic 1.

- Repeat steps 3 & 4 a few times to confirm the recorded values and to have a clear understanding of the logic levels and concept of inversion logic.
- Get the working of the NOT gate and confirm the recorded readings (Table 5) checked by your instructor.

Table 5

Input		Output		LED status ON/OFF
Logic level	Voltage level	Logic level	Voltage level	

TASK 6 : Verify the truth table of a Transistor-Transistor Logic (TTL) NOT gate IC 7404

- Record the following details for the given IC 7404.
 - Manufacturer's name
 - IC number
 - Type of package
 - IC family type
 - Internal connection diagram with pin numbers.

the IC is getting heated up, switch-off power supply and consult your instructor.

Referring to Fig 6 of exercise and IC data book, note down the following readings in Table- 6

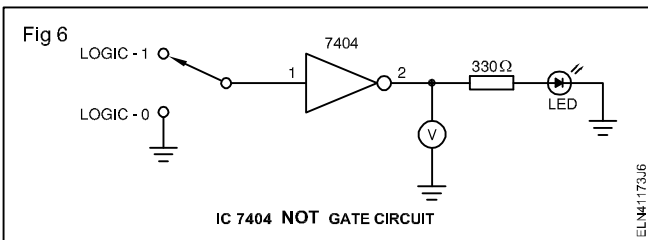

Table 7

- IC 7404 has got _____ inverters.
- Maximum I/P voltage level for Logic-0 is _____ volts.
- Minimum I/P voltage level for Logic-1 is _____ volts.
- Maximum O/P voltage level for Logic-0 is _____ volts.
- Minimum O/P voltage level for Logic-1 is _____ volts.
- In IC 7404, the V_{CC} and ground pins are _____ and _____ respectively.

Table 6

- IC number : _____
- Manufacturer name : _____
- Number of pins : _____
- Type of package : _____
- IC family type : _____
- Internal block diagram with pin numbers and details: _____

- Measure voltage level at V_{CC} and GND pins at the IC to confirm that supply is reaching the IC.
- Apply Logic 0 (Low/Ground/ 0 volt) to the input of the inverter 1 of wired IC NOT circuit. Record the output voltage, corresponding logic level and status of LED in Table 8.
- Give logic 1 (High/+ 5V) at the input of the same inverter and record the outputs as done in step 8.
- Get the recorded readings checked by your instructor.
- Modify the wiring of the circuit to test the next NOT gate between pins 3 & 4. Get it checked by your instructor.
- Repeat steps 8, 9 and 11 to test other NOT gates of the IC.

- Referring IC data book complete the details given in Table 7 and get it checked by the instructor.
- Test the IC using digital IC tester to confirm its good working condition. Exchange IC if found defective.
- Construct the NOT gate test circuit shown in Fig 6 on the general purpose IC test board/pin board. Get the constructed circuit checked by your instructor.
- Insert the IC in the IC base of the wired circuit. Make sure IC inserted as per circuit.
- Switch on the DC supply (+ 5V) to the wired circuit and check if the IC is getting excessively heated-up. If

If any gate is found to be defective, record it and consult your instructor.

- Get your work checked by your instructor.

Do not dismantle the circuit. This is required for next exercise.

- Repeat steps 1 to 12 for the CMOS NOT gate IC, CD4079 following the instructions given below;

Table 8

Input	Output																	
	Inverter-1			Inverter-2			Inverter-3			Inverter-4			Inverter-5			Inverter-6		
Level	O/P voltage	Logic level	Status of LED	O/P voltage	Logic level	Status of LED	O/P voltage	Logic level	Status of LED	O/P voltage	Logic level	Status of LED	O/P voltage	Logic level	Status of LED	O/P voltage	Logic level	Status of LED
0																		
1																		

Working fully satisfactorily Not fully satisfied Not working

4 Condition of the assembled logic probe using IC CD4079

5 Instructor's remarks Very good Good Satisfactory Poor

- Construct the circuit in a different place on the same board.
- After setting up the circuit get it checked before proceeding further.
- Use 12 volts DC for V_{CC} .
- For CMOS ICs, Logic-1 can be equal to V_{CC} .

The minimum logic-HIGH input voltage should be $= 2/3 V_{CC}$ and, maximum logic-LOW input voltage can be $= 1/3 V_{CC}$.

15 Get the work checked by your instructor.

Generate and demonstrate wave shapes for voltage and current of rectifier, single stage amplifier and oscillator, using CRO

Objectives: At the end of this exercise you shall be able to

- **construct a bridge rectifier test the output wave form**
- **test the wave shape without RC filter and with filter and calculate ripple factor**
- **test the wave shapes of a common smith amplifiers and distinguish with the input & output waves**
- **test the oscillator output wave shape and identify the frequency.**

Requirements

Tools/Instruments

- | | | | |
|------------------------------------|---------|--|------------|
| • Trainees kit | - 1 No. | • Resin core solder 60/40 | - as reqd. |
| • Oscilloscope, 20MHz, dual trace | - 1 No. | • Electrolytic capacitor 10 μ F/25V | - 1 No. |
| • Voltmeter MC 0-30V | - 1 No. | • Resistor 10K/1W | - 1 No. |
| • Multimeter | - 1 No. | • Transistor BF 195 | - 1 No. |
| • Soldering iron 25W 240V | - 1 No. | • Capacitors - 0.01 and 0.1 μ f | - 3 Nos. |
| • Function generator | - 1 No. | • Gang capacitor 25-2J | - 1 No. |
| • Regulated DC power supply 12V/1A | - 1 No. | • Resistors - 82K, 18K, 3.9K, 390 Ω /1/4W | - 1 each |

Materials/Components

- | | | | |
|---|------------|--|-----------|
| • Lug board General purpose 5 points | - 1 No. | • Diode IN914/OA79 | - 1 No. |
| • Diode IN4007 | - 4 Nos. | • Capacitor, 100 μ F/25 V, electrolytic, axial | - 1 No. |
| • Resistor 470 Ω | - 1 No. | • Capacitor, 25 μ F/25 V, electrolytic, axial | - 2 Nos. |
| • Step-down transformer, 240V 24V 500mA | - 1 No. | • Resistors 1/4 W, carbon | |
| • Multi strand wire, red, blue 19/0.3 of 600V grade | - as reqd. | 120 Ω | - 1 No. |
| • Base board (Laminated board 30 x 15 x 3mm) | - 1 No. | 470 Ω | - 1 No. |
| • Nuts, bolts and washers | - as reqd. | 1.2 K Ω | - 1 No. |
| • 3 Pin plug 6A 250V | - 1 No. | 5.6 k Ω | - 1 No. |
| | | • Hook-up wires | - 20 Cms. |

PROCEDURE

TASK 1: Construct a bridge rectifier and test the wave shapes with and without filter and calculate ripple frequency

- 1 Construct a bridge rectifier, referring to the schematic and layout diagrams. (Fig 1a & 1b)
- 2 Switch ON the circuit. Measure and record the AC input $V_{s(rms)}$ to the rectifier in Table 1
- 3 Calculate the expected output DC voltage V_{dc} across load R_L using the formula. $V_{dc} = 0.9 V_{s(rms)}$ where, $V_{s(rms)}$ is the AC input to the rectifier (refer Fig 1a). Record the value in Table 1.
- 4 Measure the DC output V_{dc} across the load R_L and record it in Table 1.
- 5 Record the difference in the calculated and measured values in Table 1. Get it checked by your instructor.
- 6 Measure and record the following parameters in Table 1 by using a CRO.
 - peak value of V_s _____
 - frequency of V_s _____
 - peak value of the pulsating V_{dc} _____
 - frequency of pulsating V_{dc} _____
 - Wave forms of output and input voltages.
- 7 Show the waveforms and record the readings to your instructor before switching off mains supply and CRO.

Table 1

Readings of two-diode full-wave rectifier

$V_{s(rms)}$ (1)	Calculated V_{dc} volts (2)	Measured V_{dc} volts (3)	Difference of (2) & (3) (4)	Peak value of V_s (5)	Frequency of V_s (6)	Peak value of pulsating V_{dc} (7)	Frequency pulsating V_{dc} (8)

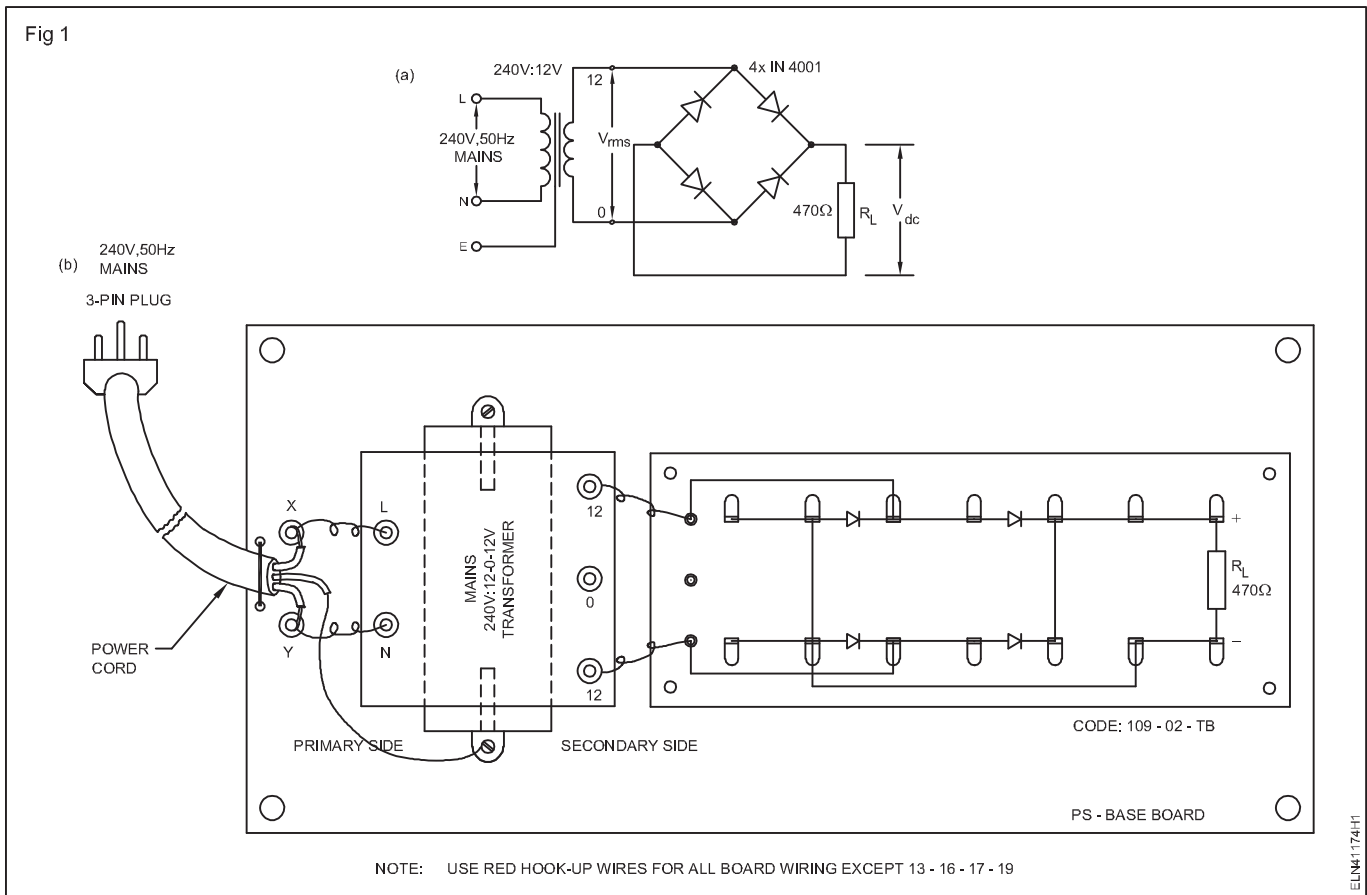

TASK 2: Measure of ripple and calculate ripple factors in bridge rectifiers with RC filter

- 1 Construct the filter circuit in the bridge rectifiers already constructed. (Fig 2)
- 2 Repeat the steps 2 to 6 of task 1. Enter the measured values in Table 2 and 3.

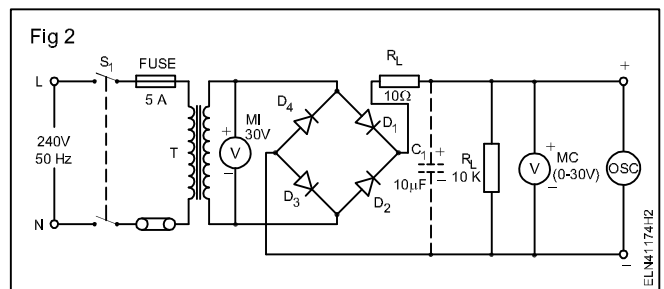
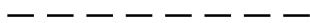

Table 2

Condition	Input AC	Output DC	AC ripple	Ripple factor = $\frac{\text{AC ripple voltage}}{\text{DC voltage}}$
Without RC filter				
With RC filter				

Table 3

Condition		
Output wave form without capacitor		
Output wave form with capacitor		



TASK 3 : Determine the voltage gain A_v of CE amplifier and distinguish input and output wave shapes

- 1 Construct the circuit of CE amplifier in Fig 3.
- 2 Apply V_{cc} measure and record I_c and I_b in Table 4.
- 3 Apply input sinewave from function generator and measure voltage gain of using CRO. Observe the input and output waves.
- 4 Record the input and output wave shapes of the CE amplifiers.
- 5 Get it checked with your instructor.

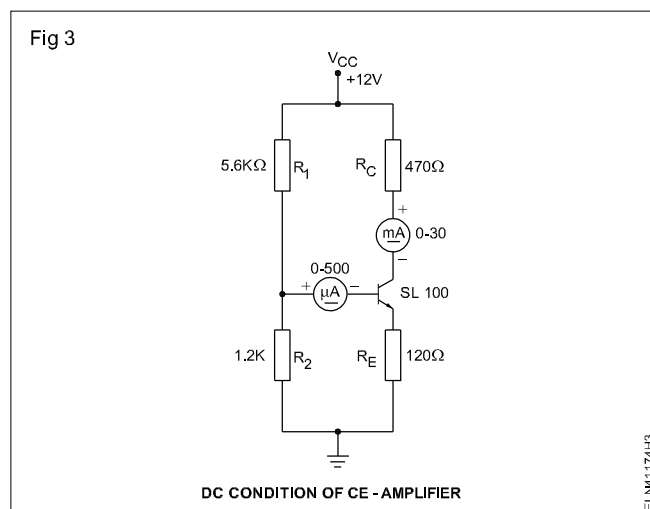
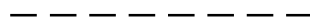

Table 4

Transistor Number	Collector I_c current	Base current I_b	V gain	Input wave shapes	Output wave shapes	Relation between input & output wave



TASK 4 : Assemble a hartley oscillator and test the waves, find frequency with different capacitor values

- 1 Test the components to confirm their good working condition.
- 2 Assemble the Hartley oscillator circuit referring to Fig 4.
- 3 Connect and switch ON + 12V-DC supply to the wired circuit. Check to ensure that the transistor is not getting heated-up.
- 5 Adjust CRO time-base to get a clear sinusoidal wave on the screen. Measure the amplitude and frequency of oscillations and record the observations below:
 - i) amplitude of oscillations
 - ii) Frequency of oscillations

If the transistor is getting heated-up, switch-OFF supply and consult your instructor.

If oscillations are not seen, tune the gang capacitor. If oscillations are still not seen, consult your instructor.

- 4 Connect the secondary terminals of the MW OSC coil, to CRO set to measure the frequency.
- 6 Get the working of the oscillator checked by your instructor.

- 7 Set the gang capacitor to one extreme end. Measure the amplitude and frequency of oscillations and enter in Table 5.
- 8 Set the gang capacitor to the other extreme end. Measure the amplitude and frequency of oscillations and enter in Table 5.
- 9 Set the position of the gang capacitor to approximately mid-position. Measure the amplitude and frequency of oscillations and enter in Table 5.
- 10 Get the recorded reading checked by your instructor.

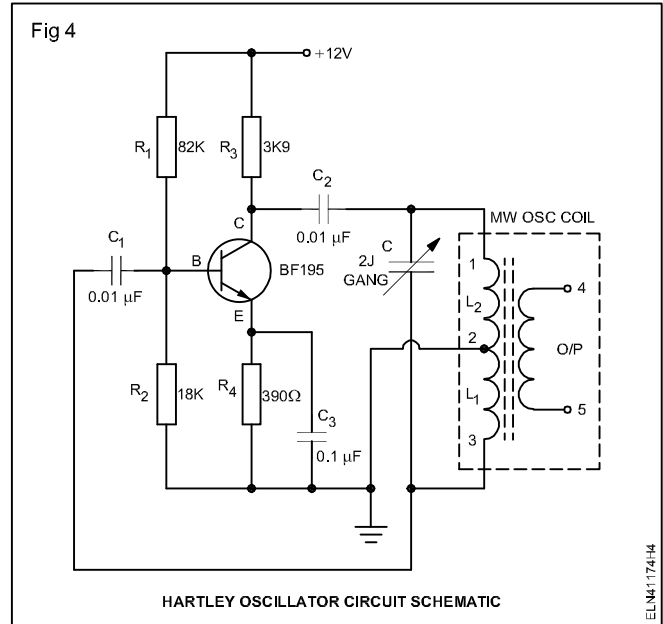

Table 5

Position of gang capacitor	Amplitude in volts peak to peak	Frequency in Hz
At one extreme end		
At other extreme end		
Mid position		

Design layout of control cabinet, assemble control elements and wiring accessories for local and remote control of induction motor

Objectives: At the end of this exercise you shall be able to

- draw the control and power circuit for remote control
- mark the layout on control panel wiring accessories remote control
- drill and tap for fixing accessories
- mount the DIN rail and accessories
- wire up the accessories
- arrange the wiring by routing, bunching and tying
- test the control panel for local and remote control of induction motor.

Requirements			
Tools/Instruments		Materials	
• Trainees tool kit	- 1 No.	• Push button red /green	- 1 each
• Scriber 100 mm	- 1 No.	• Indicator lamp with holder (red, yellow, blue)	- 1 each
• Hacksaw frame with blade- 300 mm	- 1 No.	• MCB 4 Pole 16A , 415V	- 1 No.
• Hand drilling machine 6mm capacity	- 1 No.	• Race ways	- 1 m
• HSS Drill bit 6mm & 4mm	- 1 No.	• DIN rail	- 1 m
	each	• G - channel	- 2 m
• Round nose plier 150 mm	- 1 No.	• Wire clips	- as reqd.
• Crimping tool 200 mm	- 1 No.	• Terminal connectors	- as reqd.
Instruments/Equipments		• Wire ferrule	- as reqd.
• Digital multimeter	- 1 No.	• Grommets	- as reqd.
• Megger 500V	- 1 No.	• Lug/thimble	- as reqd.
• Contactor 4 pole, 16A,240V	- 1 No.	• Cable binding straps and buttons	- 10 m
• Thermal overload relay 10A, 415V	- 1 No.	• Nylon cable ties	- 15 Nos.
• Remote station	- 1 No.	• PVC 1.5 sq mm copper cable 660V (red, black, yellow, blue, green)	- as reqd.
• Over load relay 15A, 415V	- 1 No.	• Assorted size bolt & nut	- as reqd.

PROCEDURE

TASK 1 : Identify the control accessories and wiring accessories used for control panel wiring

Instructor must serially arrange the real items of control elements used for control panel wiring, If it is not possible provide the images without their names. He can explain how to identify them with specification and uses / types.

- 1 Identify the control elements from the real objects (or) from the images.
- 2 Write the name and type of the control elements against the space provided and also write their specification and purpose / application in Table 1.
- 3 Check the identified items with your instructor.

Table 1

Sl. No.	Names of control elements and wiring accessories (from real or image)	Types of the elements (whether protective / control etc.)	Specifications	Purpose / Application
1				
2				
3				
4				
5				
6				
7				
8				

TASK 2 : Develop the layout and mark the layout in control panel

Note : Instructor has to provide a blank control panel along with power and control circuit of the local and remote control of induction motor.

- 1 Draw the layout diagram
- 2 Select and check the accessories required.
- 3 Mark the layout inside the control panel by using steel rule and scribe.
- 4 Mark for fixing holes for isolators and control devices etc., as per layout diagram.
- 5 Mark and cut the DIN rail, 'G' channel and race ways as per layout. Mark the points of drills on it to fix them inside the control panel.
- 6 Mark the drill holes in the front door of the control panel to fix the indicator lamp and push button switches.
- 7 Mark the fixing holes for the wire clips in the control panel door to run the wires. (Fig 1)

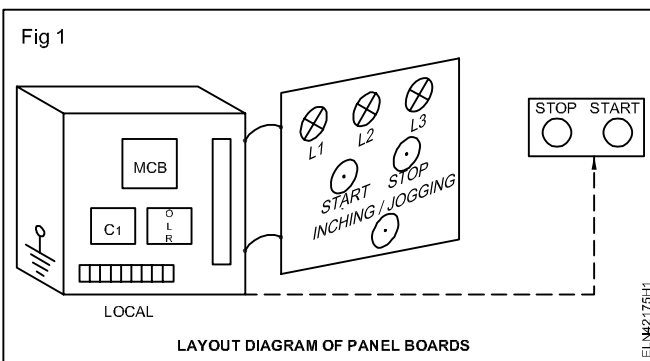

- 8 Make the drills in side the control panel to fix control devices, DIN rails, 'G' channel and race ways as per marking.
- 2 Make the through holes in race ways, DIN rails and G channel.
- 3 Fix the control accessories race ways, DIN rails and G channel using fixing screw, bolt and nuts.
- 4 Make the drills on the door of panel for indicator lamp, push button and wire clips as per marking. (Fig 2)



TASK 3 : Draw and wire the control and power circuit for local and remote control of induction motor

- 1 Draw the control circuit and power circuit and check and verify with your instructor. (Fig 3 and 4)
- 2 Label the Terminal number in the control and power circuit.
- 3 Measure and cut the cable as per layout.
- 4 Insert the ferrule Nos at the both ends of terminals as per layout and run the wires in the race ways one by one. Avoid the cross over of the wires.

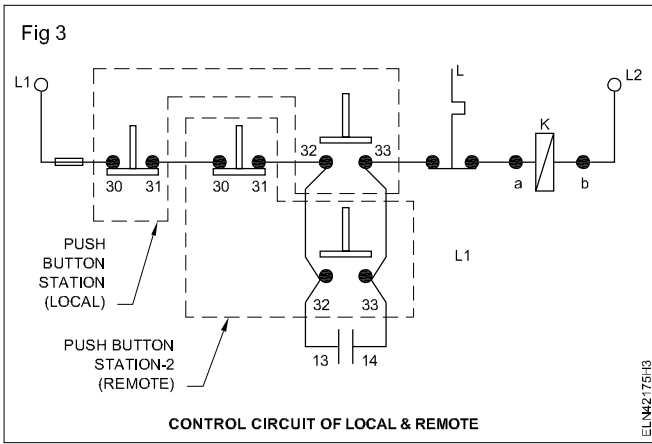

A typical control panel fitted with race ways, DIN rails, control transformer and isolator is shown in Fig 5.

Leave some extra length of wires in the race ways for easy maintenance and repair.

To avoid the cross-over first the vertical wires can be run followed by horizontal run.

- 5 Skin the wire ends and crimp with suitable lugs/thimbles.
- 6 Connect the control circuits wires as per the control circuit and terminals / ferrule table.

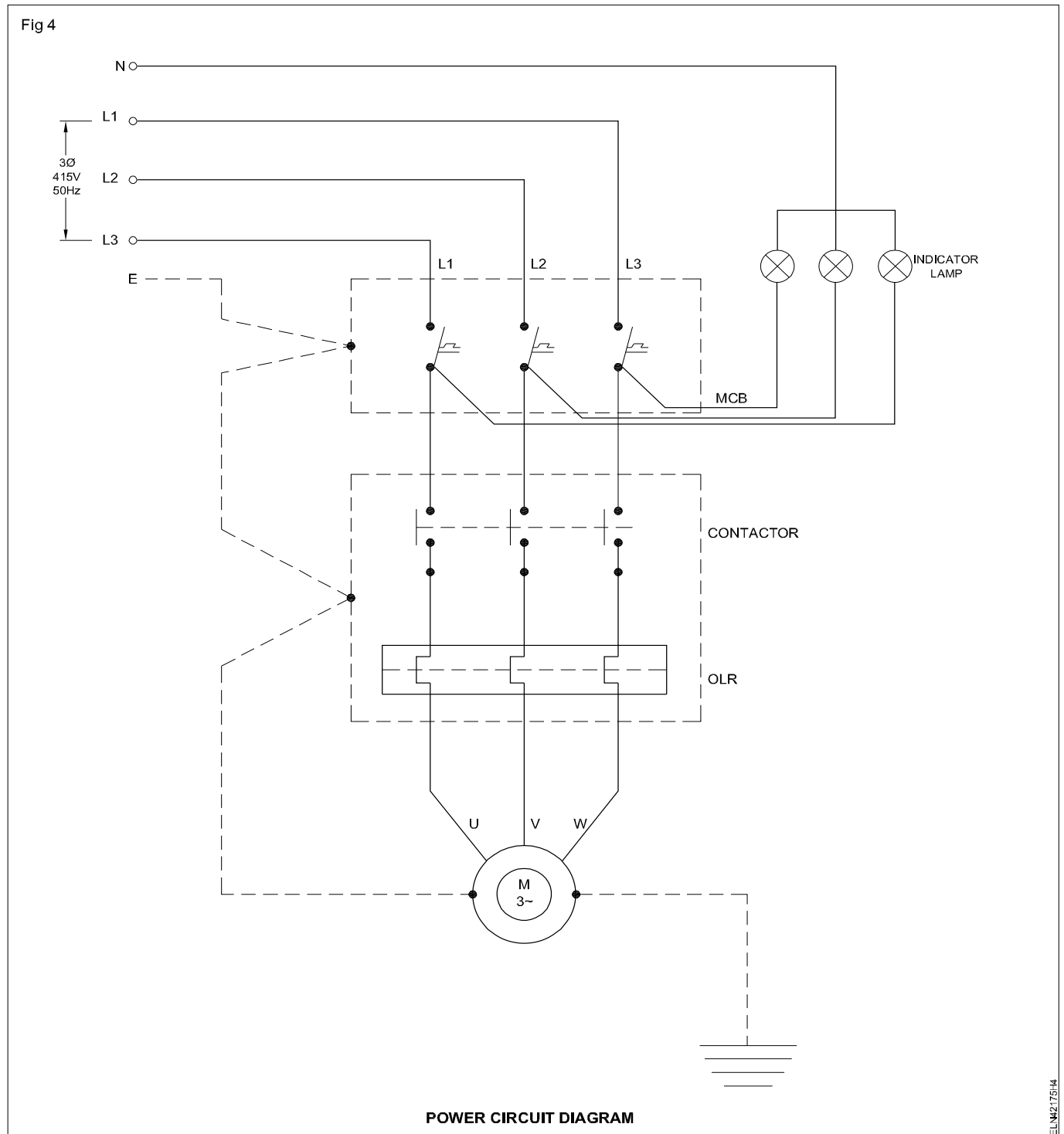

Fig 5



CONTROL PANEL WITH RACEWAYS/DIN RAILS

ELN42175H5

- 7 Connect the power circuit's wires as per the power circuit diagram and terminals / ferrule details.

Avoid the loose connection and over tightness.

- 8 Route the wires in the race ways. Punch and ties the wires in the race ways using cable binding straps and button.
- 9 Cover the PVC race ways over the wiring.

Take necessary care to avoid crushing of cable when cover the race ways.

- 10 Make the "U" loops of wires in the hinged doors. Bunch and tie the cable in the doors.
- 11 Fix the wire clips at suitable places to hold the cables in the panel door.

U loop should not disturb the movement and closing of the panel door.

- 12 Connect the incoming and out going terminals as per diagram and terminal details.

Use the grommets to avoid the strain in the cables.

- 13 Earth the panel and door.

- 14 Measure the insulation resistance of the panel.

If the IR value is less than 1 Meg ohm, take suitable remedy action.

- 15 Set the OLR in accordance with the full load current of motor.

A typical control panel with complete wiring is shown in Fig 6.

Fig 6



CONTROL PANEL WITH COMPLETE WIRING

ELN42175H6

- 16 Test the local and remote control of motor.

- 17 Show and check the control operation with your instructor.

After removing the wiring, get it verified by the instructor and preserve all the fittings for subsequence exercises.

Design layout of control cabinet, assemble control elements and wiring accessories for forward and reverse operation of induction motor

Objectives: At the end of this exercise you shall be able to

- draw the control and power circuit for forward and reverse operation of motor
- mark the layout on control panel
- wire up the accessories
- arrange the wiring by routing, bunching and tying
- test the control panel for forward and reverse of induction motor.

Requirements	
<p>Tools/Instruments</p> <ul style="list-style-type: none"> • Trainees tool kit - 1 No. • Scriber 100 mm - 1 No. • Hacksaw frame with blade- 300 mm - 1 No. • Hand drilling machine 6mm capacity - 1 No. • HSS Drill bit 6mm & 3mm - 1 No. <p style="text-align: right;">each</p> <ul style="list-style-type: none"> • Round nose plier 150 mm - 1 No. • Crimping tool 200 mm - 1 No. <p>Instruments/Equipments</p> <ul style="list-style-type: none"> • Digital multimeter - 1 No. • Megger 500V - 1 No. • Air break contactor 4pole, 16A, 240V - 2 Nos. • Overload relay 15A, 415V - 1 No. 	<p>Materials</p> <ul style="list-style-type: none"> • Push button red /green/yellow - 1 each • Indicator lamp with holder - 5 Nos. • MCB 4 Pole 16A - 1 No. • Race ways - 2 m • Wire clips - 4 Nos. • DIN rail /G - channel - 1 m • 1.5 sq.mm copper cable 660V (red, black, yellow, blue, green) - as reqd. • Terminal connectors - as reqd. • Wire ferrule - as reqd. • Grommets - as reqd. • Lug/thimble - as reqd. • Cable binding straps and buttons - as reqd. • Nylon cable ties - 10 Nos. • Assorted size bolt and nut - as reqd.

PROCEDURE

The control panel board used in the Ex.4.2.175(i) has to be retained with accessories fitted to use for this Exercise.

TASK 1 : Draw the layout and mark the layout in control panel

- 1 Draw the layout diagram for the forward and reverse control of induction motor.
- 2 Select and check the accessories required.
- 3 Mark the layout inside the control panel by using steel rule and scribe for the additional accessories.
- 4 Mark holes for fixing control for accessories etc., as per layout diagram. (Fig 1)
- 5 Mark and cut the DIN rail, 'G' channel and race ways as per layout. Mark the points of drills on it to fix them inside the control panel.
- 6 Mark the drill holes in the front door of the control panel to fix the indicator lamp and push button switches.
- 7 Mark the holes for fixing the wire clips in the control panel door to run the wires. (Fig 1)

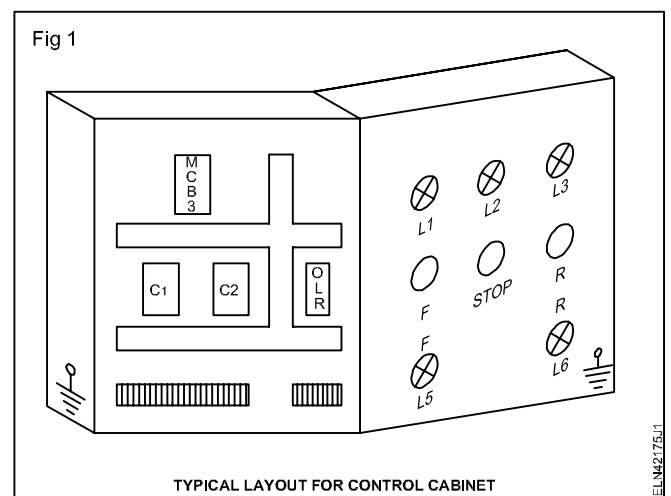

- 8 Fix the control accessories, race ways, DIN rails and 'G' channel using fixing screw and bolt nuts.
- 9 Make the drills on the door of panel for indicator lamp, push button and wire clips as per marking in Fig 2.



TASK 2 : Wire the control and power circuit for forward and reverse (F/R) control of induction motor

- 1 Draw the control and power circuit and check the correctness. (Fig 3 & 4)
- 2 Label the Terminal number in the control and power circuit.
- 3 Measure and cut the cable as per layout.

A typical control panel fitted with race ways, DIN rails, control transformer and isolator etc. is in Fig 5.

- 4 Insert the ferrule Nos at the both ends of terminals as per layout.

Leave some extra length of wires in the race ways for easy maintenance and repair.

- 5 Run the wires in the race ways one by one. Avoid the cross over of the wires.

To avoid the cross-over, run the vertical wire first, followed by horizontal runs.

- 6 Skin the wire ends and crimp with suitable lugs/thimbles

- 7 Connect the control and power circuits as per circuit diagram. (Fig 3 & 4)

- 8 Route the wires in the race ways. Punch and ties the wires in the race ways using cable binding straps and button.

Leave the excess wires if any in the bends or in the race ways.

- 9 Cover the PVC race ways over the wiring.

Take the necessary care to avoid the crushing of cable when cover the race ways.

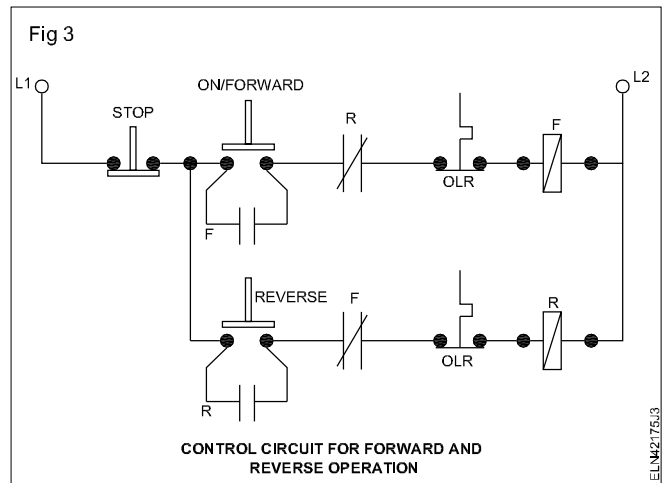

- 10 Make the "U" loops of wires in the hinged doors. Bunch and tie the cable on the doors.

- 11 Fix the wire clips at suitable places to hold the cables in the panel door.

Ensure the 'U' loop should not disturb the movement and closing of the panel door.

- 12 Connect the incoming and out going terminals as per diagram and terminal details.

Use the grommets to avoid the strain in the cables.

- 13 Earth the panel, door and metal devices.

- 14 Measure the insulation resistance of the panel.

If the IR value is less than 1 Meg ohm, take suitable remedial action.

- 15 Set the Over Load Relay (OLR) in accordance with the full load current of motor.

Fig 4

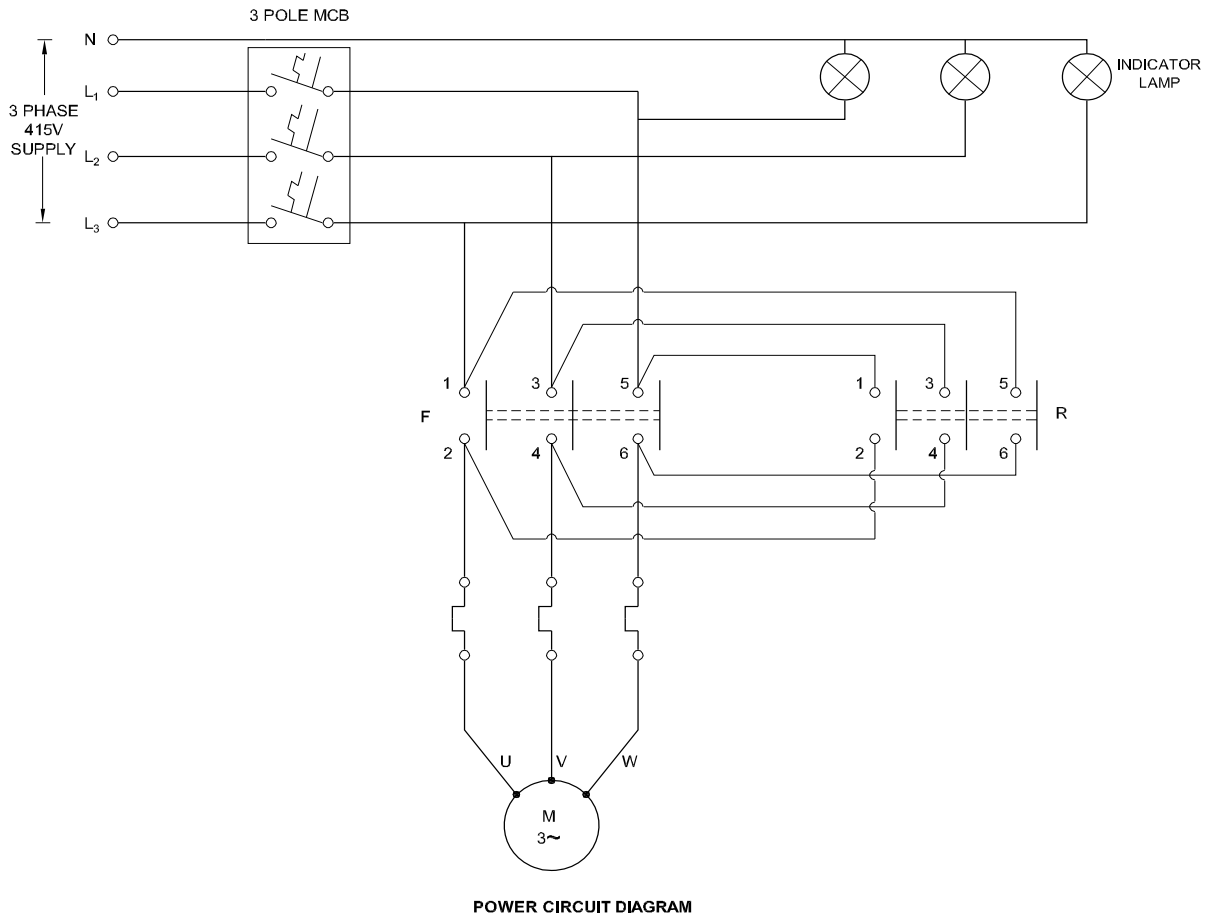

ELN42175.4

Fig 5



CONTROL PANEL WITH RACEWAYS/DIN RAILS

ELN42175.5

A typical control panel with complete wiring is shown in Fig 6.

16 Test the control panel for forward and reverse of induction motor operation.

Fig 6



CONTROL PANEL WITH COMPLETE WIRING

ELN42175.6

17 Check the proper functioning of indicating lamps when motor is in operations.

18 Show the control panel (F/R) working to your instructor for approval.

Note : Remove the wiring you did in the Ex.4.2.175(i) and preserve the remaining devices fitted for the next Exercise 4.2.175(iii)

Design layout of control cabinet, assemble control elements and wiring accessories for automatic star-delta starter with change of direction of rotation

Objectives: At the end of this exercise you shall be able to

- draw the control and power circuit of automatic star delta starter with change of direction of rotation
- mark the layout on control panel
- mount the DIN rail and accessories
- wire up the accessories
- arrange the wiring by routing, bunching and tying
- test the control panel for automatic star-delta starter with change of direction of rotation.

Requirements			
Tools/Instruments		Materials	
• Trainees tool kit	- 1 No.	• Push button green/red/green	- 1 each
• Scriber 100 mm	- 1 No.	• Indicator lamp with holder	- 5 Nos.
• Hacksaw frame with blade- 300 mm	- 1 No.	• Overload relay 0-15A, 415V	- 1 No.
• Hand drilling machine 6mm capacity	- 1 No.	• MCB 3 Pole 25A , 415V	- 1 No.
• HSS Drill bit 6mm & 3mm	- 1 No.	• Race ways	- 2 meter
• Round nose plier 150 mm	- 1 No.	• Wire clips	- 4 Nos.
• Crimping tool 200 mm	- 1 No.	• 1.5 sq.mm copper cable 650V (red, black, yellow, blue, green)	- as reqd.
Instruments/Equipments		• Terminal connectors	- as reqd.
• Digital multimeter	- 1 No.	• Wire ferrule	- as reqd.
• Megger 500V	- 1 No.	• Grommets	- as reqd.
• Contactor 4 pole, 16A, 240V, 2No+2NC	- 5 Nos.	• Lug/thimble	- as reqd.
• Timer 1 No+ 1 INC relay	- 1 No.	• Cable binding straps and buttons	- as reqd.
		• Nylon cable ties	- 10 Nos.
		• Assorted size bolt and nut	- as reqd.

PROCEDURE

The control panel board used in the Ex.No.4.2.175(ii) has to be retained with accessories fitted to use for this exercise.

TASK 1 : Draw the layout and mark the layout in control panel

- 1 Draw the layout diagram for the automatic star delta starter with change of direction of rotation.
- 2 Select and check the accessories required.
- 3 Mark the layout inside the control panel by using steel rule and scriber.
- 4 Mark for fixing holes for control accessories etc., as per layout diagram. (Fig 1)
- 5 Mark and cut the DIN rail, 'G' channel and race ways as per layout. Mark the points of drills on it to fix them inside the control panel.
- 6 Mark the drill holes in the front door of the control panel to fix the indicator lamp and push button switches.
- 7 Mark the fixing holes for the wire clips in the control panel door to run the wires. (Fig 1)



- 8 Make the drills in side the control panel to fix control accessories, DIN rails, 'G' channel and race ways as per marking.
- 9 Make the through holes in race ways, DIN rails and G channel.
- 10 Fix the control accessories race ways, DIN rails and G channel using screws and bolt nut.
- 11 Make the drills on the door of panel for indicator lamp, push button and wire clips as per marking. (Fig 2)

Fig 2



CONTROL PANEL WITH RACE WAYS/DIN RAILS

ELN42175U2

TASK 2 : Wire the control and Power circuit for automatic star delta starter with change of direction of rotation and test.

- 1 Draw the control circuit and power circuit diagram and check with your Instructor. (Fig 3 & 4)

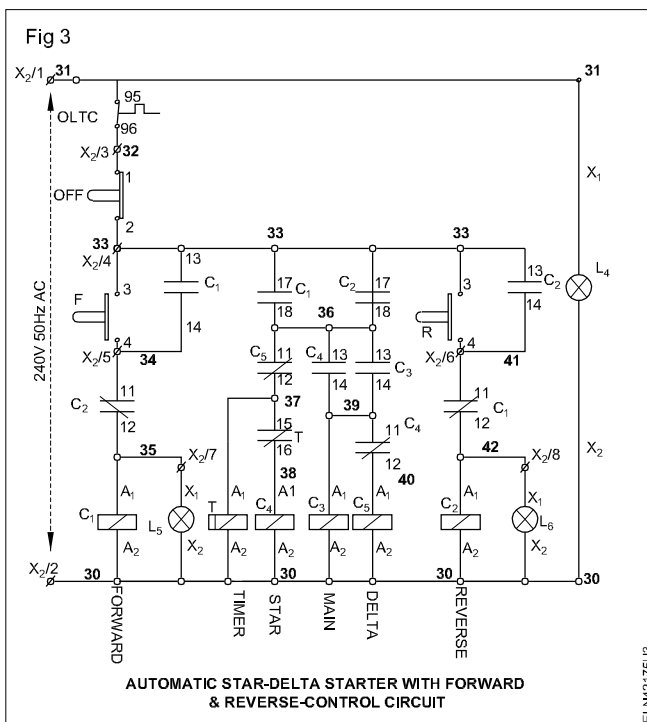

- 2 Label the Terminal number in the control and power circuit.
- 3 Measure and cut the cable as per layout.

A typical control panel fitted with race ways, DIN rails, control transformer and isolator is shown in Fig 5.

- 4 Insert the ferrule Nos at the both ends of terminals as per layout.

Leave some extra length of wires in the race ways for easy maintenance and repair.

- 5 Run the wires in the race ways one by one. Avoid the cross over of the wires.

To avoid the cross - over first the vertical wires can be run followed by horizontal run.

- 6 Skin the wire ends and crimp with suitable lugs/thimbles.
- 7 Connect the power and control circuits wires as per the control circuit diagram.
- 8 Route the wires in the race ways. Punch and ties the wires in the race ways using cable binding straps and button.

Leave the excess wires if any in bends or in the race ways.

- 9 Cover the PVC race ways over the wiring.

Take the necessary care to avoid the crushing of cable when cover the race ways.

- 10 Make the "U" loops of wires in the hinged doors. Bunch and tie the cable in the doors.
- 11 Fix the wire clips at suitable places to hold the cables in the panel door.

'U' loop should not disturb the movement and closing of the panel door.

- 12 Connect the incoming and out going terminals as per diagram and terminal details.

Fig 4

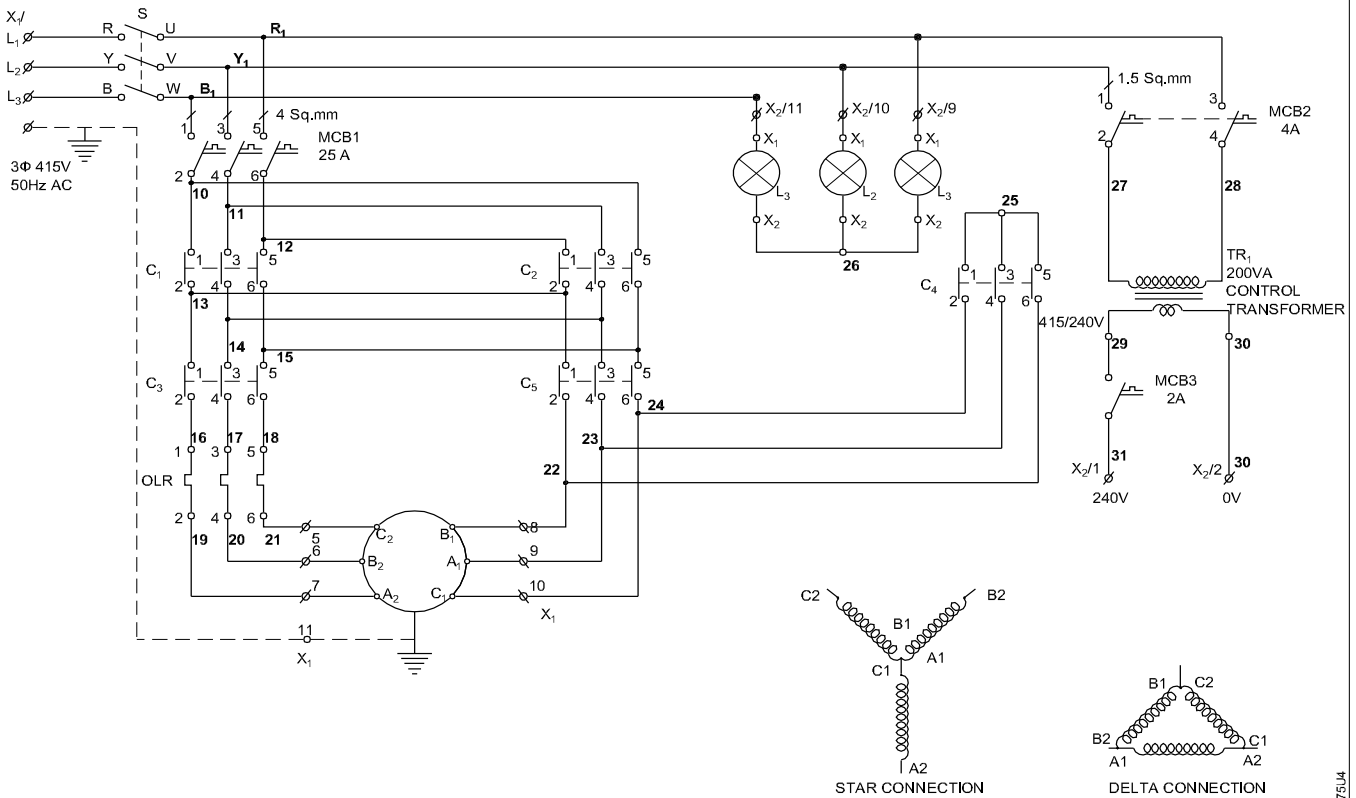

AUTOMATIC STAR-DELTA STARTER WITH FORWARD AND REVERSE-POWER CIRCUIT

ELN42175U4

Fig 5



CONTROL PANEL WITH RAYS/DIN RAILS

ELN42175U5

Use the grommets to avoid the strain in the cables.

13 Earth the panel, door, control devices.

14 Measure the insulation resistance of the panel.

If the IR value is less than 1 Meg ohm, take suitable remedial action.

15 Set the OLR in accordance with the full load current of motor.

A typical control panel with complete wiring .
(Fig 6)

Fig 6



CONTROL PANEL WITH COMPELETE WIRING

ELN42175U6

16 Connect the panel with motor and test the auto star delta starter with change of direction of rotation.

17 Show the control panel working to your instructor and get it approved.

Note: Remove the wiring as you did in the Ex.No.4.2.175(i) and preserve the remaining devices fitted for the next exercise 4.2.175(iv)

Design layout of control cabinet, assemble control elements and wiring accessories for sequential control of three motors

Objectives: At the end of this exercise you shall be able to

- draw the control and power circuit for sequential control of three motors
- mark the layout on control panel
- mount the DIN rail and accessories
- wire up the accessories
- arrange the wiring by routing, bunching and tying
- test the control panel for sequential control of 3 motors.

Requirements			
Tools/Instruments		Materials	
• Trainees tool kit	- 1 No.	• MCB 4 pole, 415V, 16A	- 1 No.
• Scriber 100 mm	- 1 No.	• Push button Red /Green	- 1 each
• Hacksaw frame with blade- 300 mm	- 1 No.	• Indicator lamp with holder	- 7 Nos.
• Hand drilling machine 6mm capacity	- 1 No.	• Limit switches 1NO+INC	- 2 Nos.
• HSS Drill bit 6mm & 3mm	- 1 No.	• Fuse base with carrier	- 9 No.
	each	• MCB 2 Pole 4A	- 1 No
• Round nose plier 150 mm	- 1 No.	• MCB single pole 2A	- 1 No.
• Crimping tool 200 mm	- 1 No.	• Race ways	- 2 m
		• Wire clips	- 4 Nos.
		• DIN rail/ G channel	- 1 m
Instruments/Equipments		• 1.5 sq.mm copper cable 660V (red, black, yellow, blue, green)	- as reqd.
• Digital multimeter	- 1 No.	• Terminal connectors	- as reqd.
• Megger 500V	- 1 No.	• Wire ferrule	- as reqd.
• Air break contactor 4 pole, 16A, 240V	- 3 No.	• Grommets	- as reqd.
• Thermal overload relay 0 -15A, 415V	- 3 Nos.	• Lug/thimble	- as reqd.
• Control transformer 415V/240V, 200VA	- 1 No.	• Cable binding straps and buttons	- as reqd.
• Time control transformer 415V, 1 No + 1 NC	- 2 Nos.	• Nylon cable ties	- 10 Nos.
		• Assorted size bolt and nut	- as reqd.

PROCEDURE

The control panel board used in the Ex.No.4.2.175 (iii) has to be retained with accessories, fitted, to use for this exercise.

TASK 1 : Draw the layout and mark the layout in control panel

Note : Instructors have to provide a blank control panel along with power and control circuit of the local and remote control of induction motor.

- 1 Draw the layout diagram for the sequential control of three motors.
- 2 Select and check the accessories required.
- 3 Mark the layout inside the control panel by using steel rule and scribe.
- 4 Mark for fixing holes for isolators and control transformer etc., as per layout diagram.
- 5 Mark and cut the DIN rail, 'G' channel and race ways as per layout. Mark the points of drills on it to fix them inside the control panel.
- 6 Mark the drill holes in the front door of the control panel to fix the indicator lamp and push button switches.
- 7 Mark the fixing holes for the wire clips in the control panel door to run the wires. (Fig 1)
- 8 Make the drills in side the control panel to fix isolator, control transformer, DIN rails, 'G' channel and race ways as per marking.
- 9 Make the through holes in race ways, DIN rails and G channel.

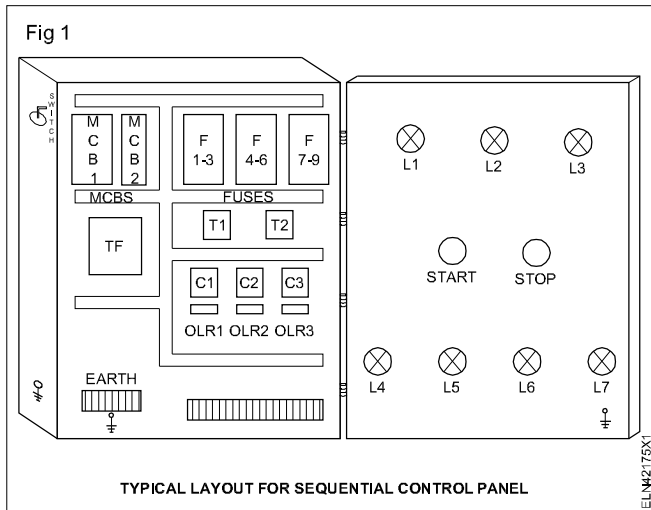

10 Fix the race ways, DIN rails and G channel using fixing screw.

11 Make the drills on the door of panel for indicator lamp, push button and wire clips as per marking. (Fig 1 and 2)

TASK 2 : Wire the control and Power circuit for sequential control of three motors and test

1 Draw the control and power circuit diagram and check with your Instructor. (Fig 3 and 4)

2 Label the Terminal number in the control and power circuit.

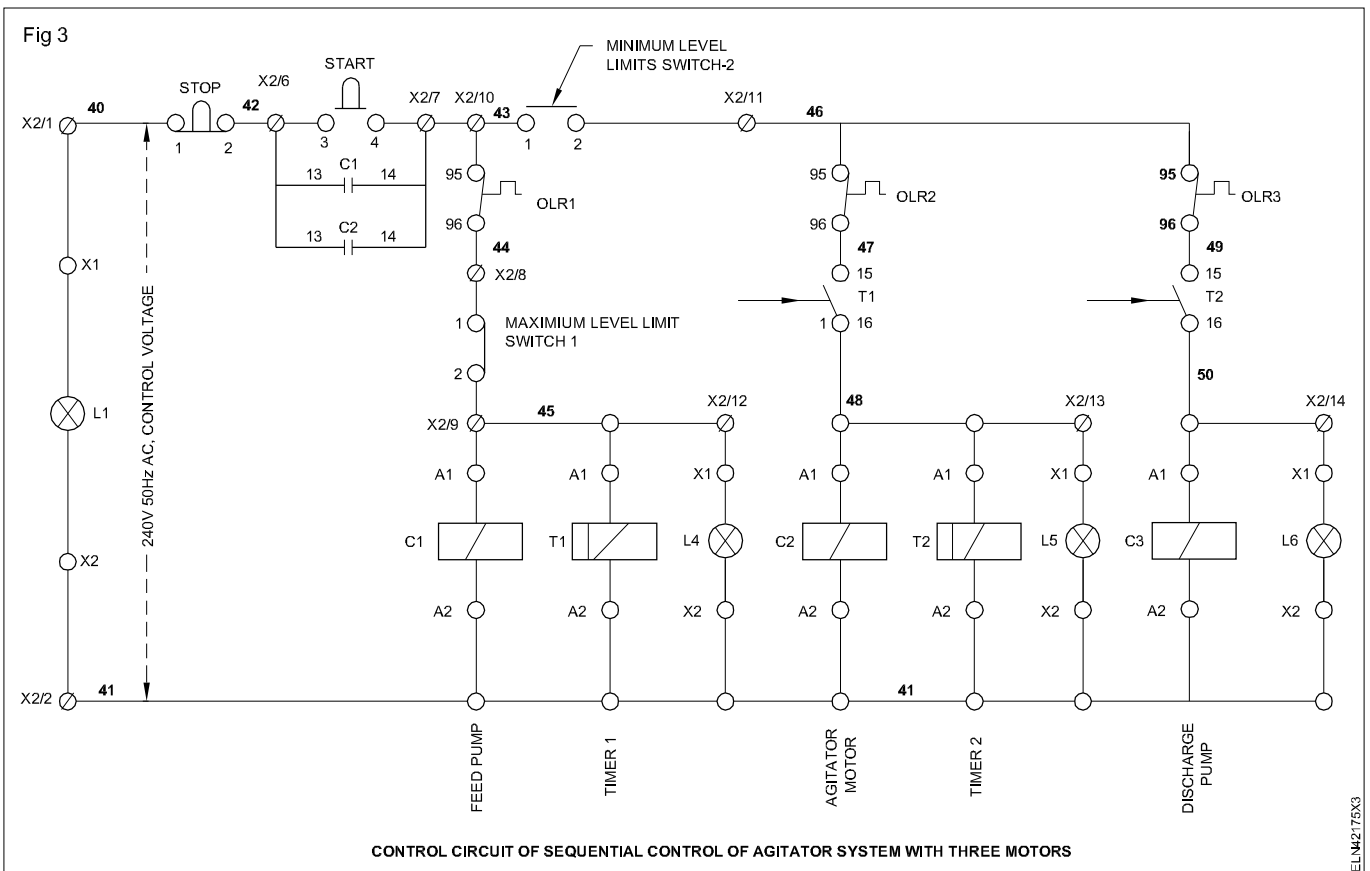

3 Measure and cut the cable as per layout.

4 Insert the ferrule Nos at the both ends of terminals as per layout.

A typical control panel fitted with race ways, DIN rails, control transformer and isolator. (Fig 5)

Leave some extra length of wires in the race ways for easy maintenance and repair.

Fig 4

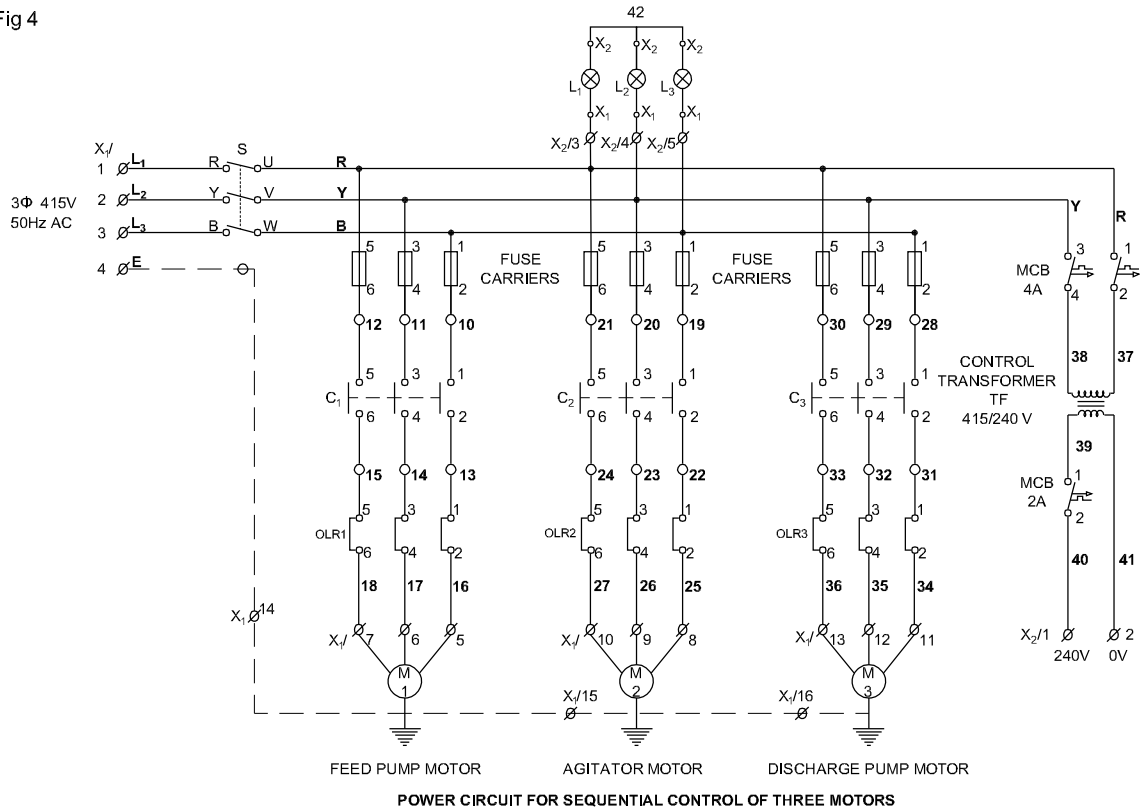

ELN42175X4

Fig 5



ELN42175X5

- 5 Run the wires in the race ways one by one. Avoid the cross over of the wires.

To avoid the cross - over the vertical wires can be run followed by horizontal run.

- 6 Skin the wire ends and crimp with suitable lugs/thimbles.
- 7 Connect the power and control circuits wires as per the circuit diagram.

- 8 Route the wires in the race ways. Punch and ties the wires in the race ways using cable binding straps and button.

Leave the excess wires if any in the bends or in the race ways.

- 9 Cover the PVC race ways over the wiring.

Take the necessary care to avoid the crushing of cable when covering the race ways.

- 10 Make the "U" loops of wires in the hinged doors. Bunch and tie the cable in the doors.

- 11 Fix the wire clips at suitable places to hold the cables in the panel door.

'U' loop should not disturb the movement and closing of the panel door.

- 12 Connect the incoming and out going terminals as per diagram and terminal details.

Use the grommets to avoid the strain in the cables.

- 13 Earth the panel, door, control transformer and motors.

If the multiple earths are used, use a common earth terminals and strips.

- 14 Measure the insulation resistance of the panel.

If the IR value is less than 1 Meg ohm, take suitable remedial action.

15 Set the OLR in accordance with the full load current of motor.

A typical control panel with complete wiring is shown in Fig 6.

15 Test the control panel for sequential operation of 3 motors.

Note: Remove the wiring and preserve the remaining control elements fitted with panel for the next exercise No. 4.2.176.

16 Report and get it checked with your instructor.

Fig 6



CONTROL PANEL WITH COMPLETE WIRING

ELN42175X6

Carryout wiring of control cabinet as per wiring diagram, bunching of XLPE cables channeling, tying and checking etc.

Objectives: At the end of this exercise you shall be able to

- verify the wiring diagram panel board and wire up
- bunch the Cross Linked Polyethylene (XLPE) cables
- channel and tie the cables
- check the wiring.

Requirements			
Tools/Equipments/Instruments			
• Trainees tool kit	- 1 No.	• Ferrule	- as reqd.
• Multimeters	- 1 No.	• PVC channel	- as reqd.
• Wire cutter/stripper	- 1 No.	• G channel	- as reqd.
Materials		• Terminal connector	- as reqd.
• Panel board - 3'x2'x1' - Metal box with winged front door	- 1 No.	• Belt traps	- as reqd.
• DIN rails/race ways	- as reqd.	• XLPE cable 1.5 sq.mm 600V	- as reqd.
• Screws, nuts and bolts	- as reqd.	• 1 sq.mm cable (copper)	- as reqd.
• Tying clips	- as reqd.	• Wire sleeves	- as reqd.
		• Wire clips	- as reqd.
		• Grommets	- as reqd.
		• Banana sockets (5 mm)	- 1 No.

PROCEDURE

TASK 1 : Wire up control cabinet as per diagram with bunching, channeling, typing and checking etc.

The control panel board used in the Ex.No.4.2.175(iv) has to be retained with control accessories fitted is to used for this exercise. For the wiring XLPE cables to be used.

- 1 Draw the wiring diagram and wire up as per the diagram.

Follow the colour coding of cables used for line controller, neutral and ground connections.

Inter connections of devices may be used same colour. Supply line, load line should he colour coded and numbered using ferrule.

- 2 Bunch the XLPE cables by using the tie clips and wire clips. (Fig 1)
- 3 Apply belt traps for excessive bunch of cables.
- 4 Make a U loop on the bunch of cables when it is connected to front door. (Fig 2)
- 5 Cut excessive tie ends and other excessive parts to make a neat bunching of cables.

Clean the panel board and preserve for next Exercise No.4.2.177.

- 6 Show the work done on the panel board to your instructor and get approval.



- 7 Check the wiring for its correctness.

Fig 2



CONTROL PANEL WITH COMPLETE WIRING

ELN42176H2

TASK 2 : Connect the control panel with 3 phase induction motor

- 1 Draw the circuit diagram for the control panel with 3 phase induction motor. (Fig 3)
- 2 Wire up the control panel to the 3 phase motor in conduct wiring.
- 3 Provide double earthing for the motor.
- 4 Test the wiring for the proper operation of control panel controls with motor.
- 5 Check the controls of control panel for changing the direction of rotation of motor.
- 6 Get it checked with your instructor.

Fig 3

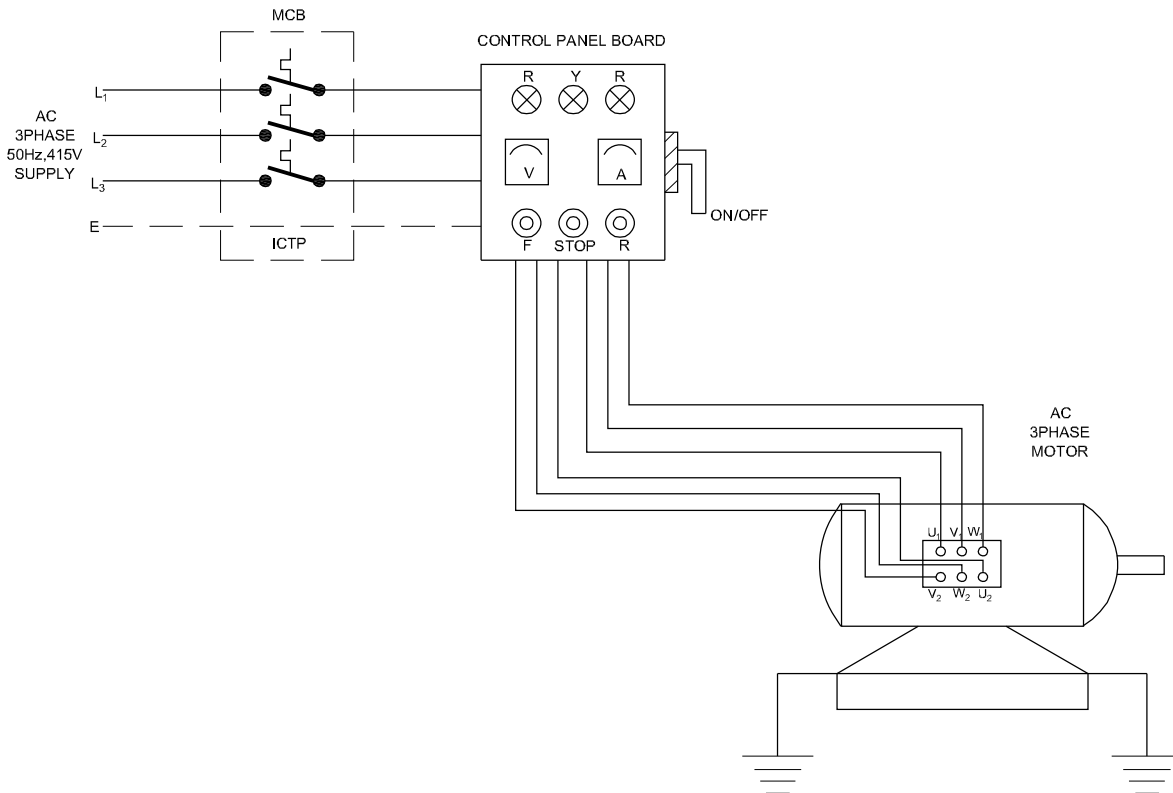

ELN42176H3

Mount various control elements (e.g) circuit breakers, relays, contactors and timers etc.

Objectives: At the end of this exercise you shall be able to

- **drill the holes in the marked places**
- **Mount the circuit breakers, relays, contactors and timer**
- **connect the cables to the control elements.**

Requirements	
<p>Tools/Equipments/Machines</p> <ul style="list-style-type: none"> • Trainees tool kit - 1 No. • Multimeter - 1 No. • Wire cutter/striper - 1 No. • Needle file set - 1 Set. • Round file set - 1 No. • Hand drilling machine (electric) 6mm - 1 No. • Half round file smooth-150 mm - 1 No. • Flat file smooth-150 mm - 1 No. 	<p>Materials</p> <ul style="list-style-type: none"> • MCB 4 pole, 415V/16A - 1 No. • OLR- 3 phase 415V/0-15A - 1 No. • Contactors - 3 phase, 415V/16A 240V coil - 5 Nos. • Timer - 1 phase, 10 sec - 2 Nos. • Push button - 240V, NC/NO red & green - 4 Nos. • Indicating lamp with holder RYB - 3 Nos. • Limit switch - 1 No. • ON-OFF rotary switch 3 phase 32A - 1 No.

PROCEDURE

The panel board used in the Ex.No.4.2.176 is to be used for this exercise.

TASK 1: Mark and make holes for mounting devices

- 1 Measure the total area of base plate on four panel board, where devices are to be mounted.
- 2 Identify and check the area required to mount the devices like circuit breaker, contactor, push button, OLR, ON-OFF rotary switch, Timer, etc: as per the total quantity available.
- 3 Mark the plates where to fix the DIN rail and race ways to mount circuit breaker, contactors. (Fig 1)

While marking the layout for mounting devices, it is distributed equally to the whole area uniformly. Do not fix all the items in one end. Keep some space for future needs.

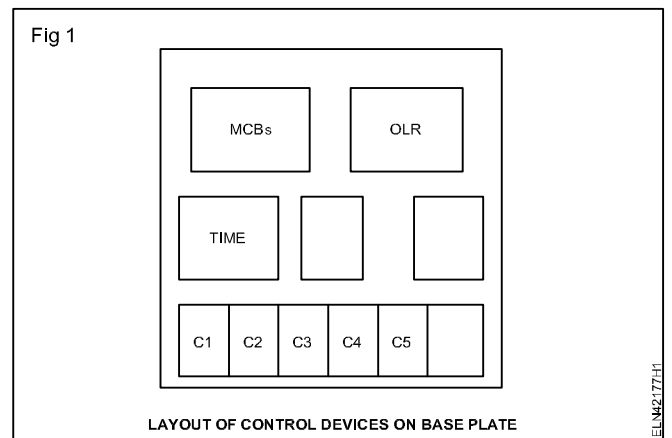

- 4 Make hole by electric drill to the size of nut and bolts. If the bolt is not free in through holes, use needle round file or bigger bits to make the bolt free going.

- 5 Fix the devices according to the layout on base plate check each devices for its rigidity and position correctness and get it checked.

TASK 2: Connect cables to control devices and checking the continuity

- 1 Check the XLPE cables for continuity and tighten before connecting to the device.
- 2 Connect all the cable to the respective terminals and connecting points to the devices, fitted on the base plate.
- 3 Connect the relay coil, contactor coil, etc to a external source of working voltage and confirm the function especially in the Normally Close (NC) and Normally Open (NO) no contacts of push buttons and contactors.
- 4 Report to your instructor for approval.

Identify and install required measuring instruments and sensors in control panel

Objectives: At the end of this exercise you shall be able to

- identify and fix instruments to measure electrical quantities
- identify the sensors and fix it on the panel board.

Requirements

Tools/Equipments/Machines

- Trainees tool kit - 1 No.
- Wire cutter/striper - 1 No.
- Hard drilling machine (electrical) 6mm - 1 No.
- Needle file set (set of 5) - 1 Set.
- Round file smooth - 150 mm - 1 No.
- Flat file smooth - 150 mm - 1 No.
- Tachometer - digital - 3 1/2 digit along with tacho generator set - 1 No.
- Single phase frequency meter digital - 3 1/2 digit - 1 No.

- Temperature indicator - digital 3 1/2 digit - along with thermister sensor unit - 1 No.
- Voltmeter - 0-600V - digital - 1 No.
- Voltmeter - 0-300V - digital - 1 No.
- Ampere meter 0-30A digital 3 1/2 digit - 3 Nos.

Materials

- Nut and bolt (Assorted sizes) - as reqd.
- Washer (Ordinary & spring type) difficult sizes - as reqd.
- 1 sq.mm cable - as reqd.

PROCEDURE

The panel board used in the Ex.No.4.2.177 is to be used for this exercise with accessories.

TASK 1: Fix panel meters and indicators on front panel

- 1 Identify and select proper range of instruments (voltmeter, ammeter etc..) suitable for this control panel.
- 2 Identify and select the required sensors (for temperature and speed) for this control panel.

The control devices are fitted on base cover and indicators are to be fitted on front panel. Wiring is terminated in respective points to be connected in the instruments. Proper sockets for terminating sensor outputs are to be provided on the front panel.

- 3 Mark the positions to fix the indicators on front panel (Line indicators, tripping indicators etc.)
- 4 Make holes for fixing the meters and other fixtures on front panel.
- 5 Fix the meters and indicators on front panel.

Distribution of gadgets on fixing in front panel should be uniform. Proper arrangement and distribution to have a good look on the front panel required. Do not crowd the devices at one places, and indicate devices like line indicator, trip indicator should be at top of the front panel as in Fig 1.

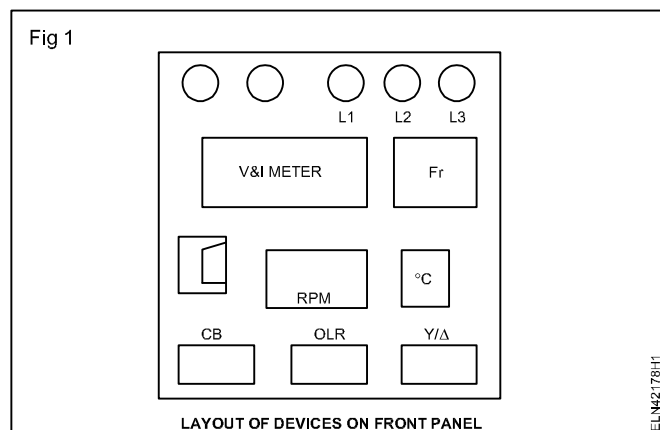

- 6 Wire the fitting in front panel using suitable cables.

Bunching or typing cables in front panel board is to be done if necessary.

- 7 Check the continuity of cables wired inside the panel board.
- 8 Report to your instructor.

Test the control panel for its performance

- Objectives:** At the end of this exercise you shall be able to
- test the control panel for any short circuit earthing with fitted devices
 - test the earthing points connections with connected control devices
 - energise and test the panel board for its working condition.

Requirements			
Tools/Equipments/Machines		Materials	
• Trainees tool kit	- 1 No.	• Connecting leads	- as reqd.
• Megger 1000V	- 1 No.		

PROCEDURE

The panel board used for the Ex.No.178 is to be used for this Exercise with complete accessories and wiring.

The panel board with accessories and wiring is to be preserved for this Exercise No.4.2.179

- 1 Check the Insulation Resistance (IR) value of contactors circuit breakers etc, (Fig 1) enter the values in Table 1.
- 2 Check for any short circuit/open circuit fault.(Fig 1)
- 6 Complete your testing and show to your instructor for approval.

If any IR value shows abnormal or very low, consult with your instructor.

- 3 Switch 'ON' the supply to the panel board and verify the functions of line indicator, meters etc.
- 4 Test the contactor, push button switch, timer for its function. Enter the status in Table 1.
- 5 Switch 'ON' the motor and check the functions of sensors (speed and temperature)

If any control device found faulty replace new control devices and test it.

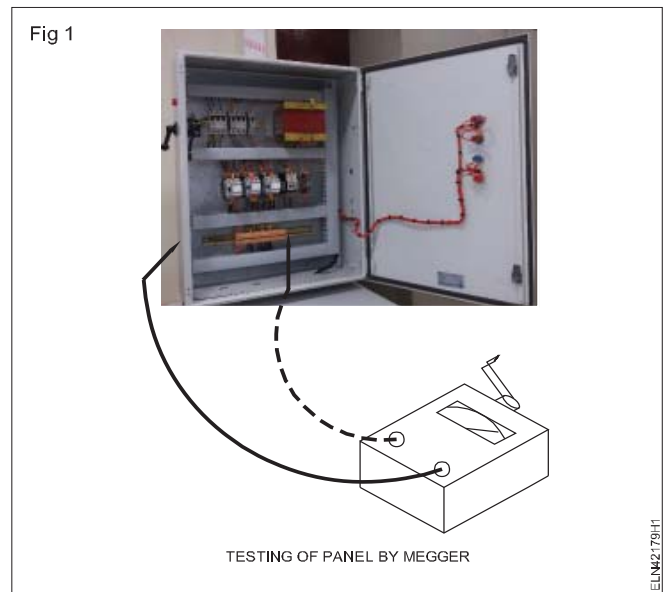

Table 1

SI.No	Description of the items	Megger value in MΩ	Condition OK / not OK
1	Overload relay		
2	Contactor		
3	Circuit breaker		
4	Voltmeter		
5	Ammeter		
6	Frequency meter		
7	Temperature indicator		
8	Tachometer/revolution counter		
9	Indicators		

Perform speed control of DC motor using thyristors/DC drive

Objectives : At the end of this exercise you shall be able to

- read and interpret the name plate details of DC drive
- connect the input/ output terminals of DC drive to motor operate the load
- control the motor speed by using DC drive and operate motor with 1/4th, 1/2th, 3/4th, load
- reverse the DOR by using DC drive and operate motor with different speed.

Requirement	
Tools/Instruments	
<ul style="list-style-type: none"> • Insulated combination pliers 150 mm - 1 No. • Screw driver 200 mm - 1 No. • Connector screw driver 100 mm - 1 No. • Electrician's knife 100 mm - 1 No. • Round nose plier 150 mm - 1 No. • MC voltmeters - 0 - 250 V - 1 No. 	<ul style="list-style-type: none"> • Lamp load : 2000 W (500W x 4) - 1 No. • DC drive 3HP, 220V - 1 No.
Equipment/Machines	
<ul style="list-style-type: none"> • DC motor 3 HP, 220V coupled with DC generator 2KW, 220V - 1 No. 	Materials
	<ul style="list-style-type: none"> • PVC insulated standard copper cable 1.5 sq.mm, 660V - 15 m. • PVC insulated flexible cable 14/0.2 mm - 3 m. • Insulation tape - 1 No.

PROCEDURE

TASK 1: Connect the input/ output terminals of DC drive to DC motor to operate the load

- 1 Note down name plate details of the given motor DC drive and lamp load. (Table 1, Table 2 and Table 3)
- 2 Check and identify terminals of the DC motor and DC drive.

Table 1

DC Motor name plate - details

Manufacturer _____	Speed _____ RPM
Make _____	Insulation class _____
Armature voltage _____ V	Rated current _____ A
Field voltage _____ V	
Power _____ KW/HP	

Table.2

Name plate details of DC drive

1	Rated supply voltage armature	V	
2	Rated input current armature	A	
3	Rated supply voltage electronics supply	V	
4	Rated supply voltage field	V	
5	Rated frequency	Hz	
6	Rated DC current	A	
7	Overload capability	A	

Table 2 (Contd.)
Name plate details of DC drive

8	Rated output	KW	
9	Power at rated DC current (approx.)	w	
10	Rated DC voltage field	V	
11	Rated DC current field	A	
12	Operational ambient temperature	°C	
13	Storage and transport temperature	°C	
14	Installation altitude above sea level	°C	
15	Dimensions (H x W x D)	mm	

Lamp load

Connect with main switch/MCB, 4 Nos of 500 W clear lamps fitted in a enclosure having individual ON - OFF facility.

Table 3

Make & Sl.No		
Rated Mains	V	
Rated Power	KW	

- 3 Remove the drive cover. Identify and trace the internal connection and get it approved by the instructor.
- 4 Select the ICTP switch /MCB, cables and fuse - wire according to the rating of the motor.
- 5 Draw the circuit diagram and connect the ICTP, MCB, drive and the motor, and get it approved by the instructor.(Fig 1)
- 6 Connect double earth independently for the main switch, DC drive and the motor.

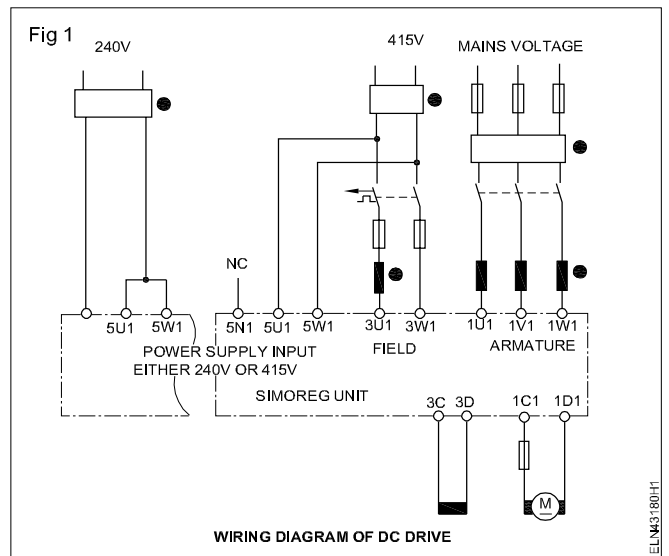

- 7 Check the supply and ensure for proper rating of fuses main switch according to the motor rating.

Improper connection of DC drives leads to shock and material damage.

TASK 2 : Control the speed by setting the parameter of different load and speed

- 1 Select the suitable type of model DC drive with code. (Fig 2)
- 2 Connect MCB, DC drive, M.G set and lamp load. (Fig 3)
- 3 Switch ON power supply.
- 4 Press ON button and measure the speed of the motor by using the Tachometer before loading. Record the readings in Table 4.
- 5 Load the motor by 1/4th load; by switching 'ON' one lamp. Record the current , voltage, frequency and voltage in load terminal, vary the speed and observe the readings.

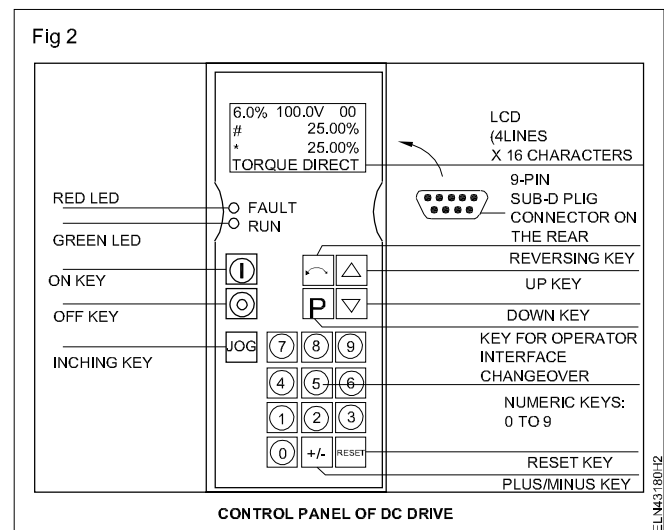

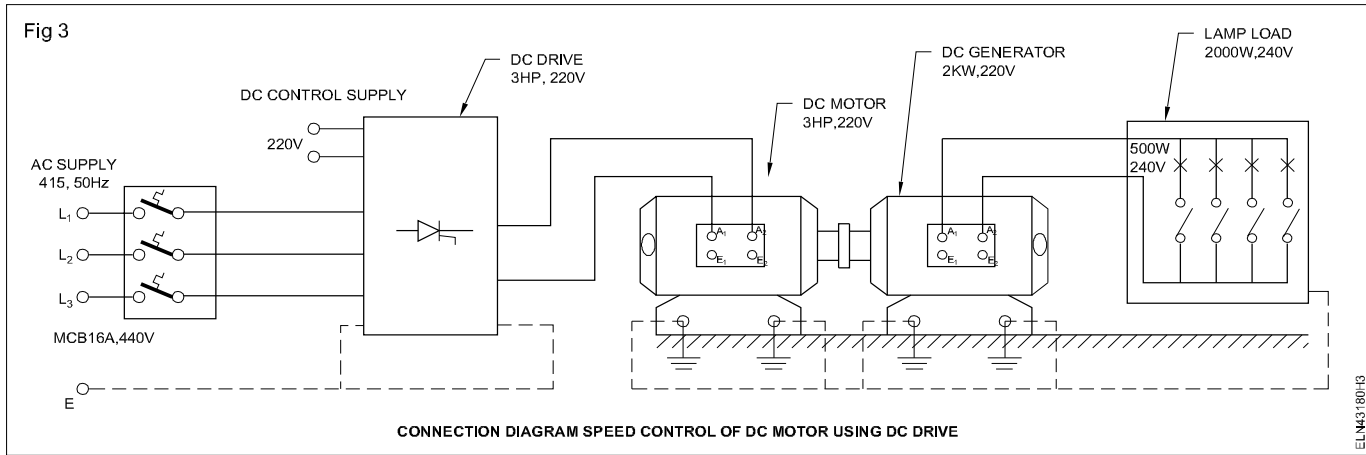

Table 4

Sl.No	Load	Armature voltage in volt	Field voltage in volt	Load		Motor speed in RPM
				Voltage (Volts)	Current (Amp)	
1	1/4 th					
2	1/2 th					
3	3/4 th					
4	Full					

- Load the motor further and switch ON another lamp (Total load now (500 W + 500W=1000W). Record all the readings in Table 4. Vary the speed with 1/2th load and observe the readings and record in Table 4.
- Load further to 3/4th load (500+ 500 + 500=1500W) and repeat step 5 and record the reading in Table 4.

Switch 'OFF' the motor instantly, if anything noticed irregular consult your Instructor.

- If motor maintaining the rated frequency after loading 3/4th load. Load the motor to full load (500+ 500 + 500+500=2000W) condition and switch 'ON' all the

four lamps . Record all readings and repeat step -5.

- Press 'OFF' switch once it is over and check the readings you recorded.

If the frequency reduced considerably when the motor operates in higher loads; Do not run the motor. Consult with your instructor.

- Remove all the connection and supply cables from the motor and supply.

- Record your observations.

TASK 3 : Reverse the direction of rotation by using DC drive

- Connect the AC supply to the input and output terminals of DC drive when the output terminals connected to armature and field of the motor, without connecting load.
- Switch 'ON' power supply main switch.
- Press 'ON' key and note the direction of running (forward direction).
- Press reversing key and check the changing of direction of rotation of DC motor.

Wait, until the motor will obtain stability and then change the DOR.

- Press 'OFF' key to stop the drive.

- Turn 'OFF' main power supply to DC drive and disconnect the DC drive.

Improper connection of DC drive results shock and material damage.

You may have DC drive of different model / make. So refer the drive instruction in manual and take help of your instructor.

The DC drive can be programmed through PC after loading the software in the PC.

The programming procedure /keys may differ according to make /model of the drive in your institute refer to the instruction m a n u a l before connecting the drive.

Perform speed control and reversing the direction of rotation of AC motors by using thyristors/AC drive

Objectives: At the end of this exercise you shall be able to

- read and interpret the name plate details of AC drive
- connect the input / output terminals of AC drive through AC motor
- identify the operating buttons on AC drive
- control the motors speed by using AC drive
- reverse the directions of rotation of 3 phase induction motor by using AC drive.

Requirements			
Tools/Instruments	Equipments/Machines		
<ul style="list-style-type: none"> • Insulated combination pliers 150 mm - 1 No. • Screw driver 200 mm - 1 No. • Connector 100mm - 1 No. • Electrician's knife 100mm - 1 No. • Round nose plier 150 mm - 1 No. 	<ul style="list-style-type: none"> • 3 Phase induction motor 5 H.P/415V - 1 No. • AC drive 3 phase 415V, 2HP - 1 No. 		
	Materials		
	<ul style="list-style-type: none"> • PVC insulated standard copper cable 1.5 sq.mm - 15 m • PVC insulated flexible cable 14/0.2 mm - 2 m • Insulated tape - 1 m • Fuse wire - as reqd. 		

PROCEDURE

TASK 1 : Connect the input/output terminals of AC drive through AC motor

- 1 Note down the name plate details of the given motor and AC drive and enter them in Table 1 & 2.
- 2 Identify the terminals of the 3 - phase induction motor.

Table 1

AC motor name plate - details

Manufacturer _____	Rated frequency _____ Hz
Model _____	Speed _____ RPM
Power _____ KW/HP	Insulation class _____
Voltage _____ Volt	Rated current _____ A

Table 2

AC drive name plate - details

Manufacturer _____	Model : _____
I/P voltage _____ V	
I/P frequency _____ Hz	
O/P frequency _____ Hz	
Serial Interface type _____	
Output voltage _____ V	
Power range _____ HP/KW	
Control type _____	
Braking type _____	

- Identify and trace the internal circuit of AC drive and get it approved by the instructor.
- Check the switch /MCB , cables and fuse - wire rating and match with motor rating.
- Draw the connection diagram of ICTP, drive, motor and get it approved by the instructor.

- Connect the motor, AC drive, main switch as per approved diagram and get it checked the instructor. (Ref. Fig 1)
- Connect double earth independently for the main switch, AC drive and the motor.

Improper connection of AC drive results shock and material damage.

TASK 2 : Connect, run the motor and setting the parameter of different speed

- Select the suitable type of model AC drive.
- Connect and wire the AC drive input power supply with terminals R/L1, S/L2, T/L3, when the output terminals U/T1, V/T2, W/T3, are connected to the motor. (Fig.1)
- Switch ON the power supply main.
- Press RUN/STOP button. The motor will run. (Ref. Fig 1 Measure the speed of motor by using the Tachometer and record it _____ RPM.
- Increase and decrease the frequency and check the change in speed of the motor.
- Press 'STOP' button and turn 'OFF' main power supply to disconnect the supply.

Improper connection of AC drive results shock and material damage.

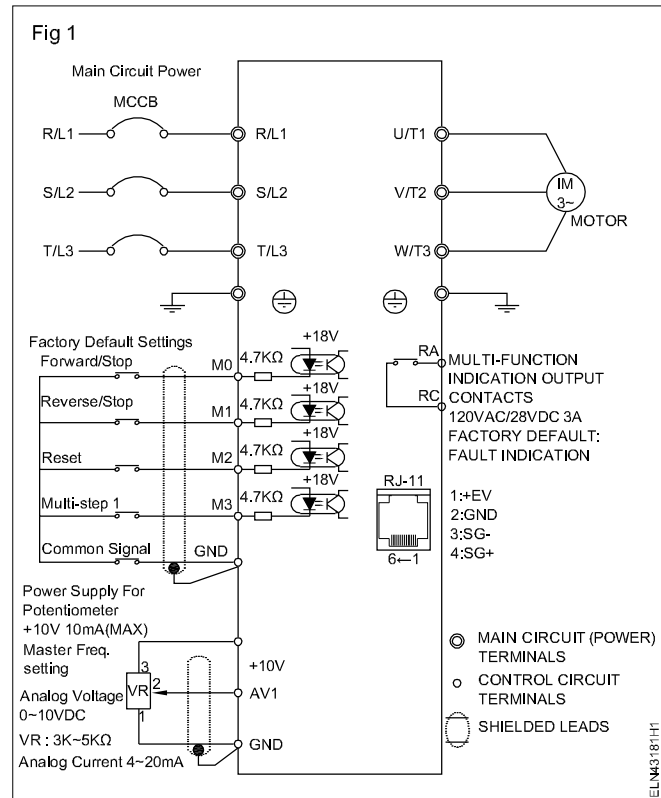

TASK 3 : Reverse the direction of rotation in AC motor by setting in AC drive

- Switch ON the power supply main.
- Press key RUN/STOP button (Ref.Fig 2). The motor will run in forward direction.
- Set the parameter for reverse direction. (Ref.Fig 2)
- Press RUN / STOP, button key, The motor will run in reverse direction.
- Press the STOP button to stop the motor.

Improper connection of AC drive results shock and material damage.

The motor will run as you press the key and will stop as you leave the key

- Turn 'off' the power supply and disconnect the drive.

Do not run the motor at low speed for longer time. Because the motor cooling will not be effective due to low fan speed. So motor will heat up.

The programming procedure /keys may differ according to the make model of the drive in your institute. Refer to the drive instruction manual and take help of your instructor.

Fig 2

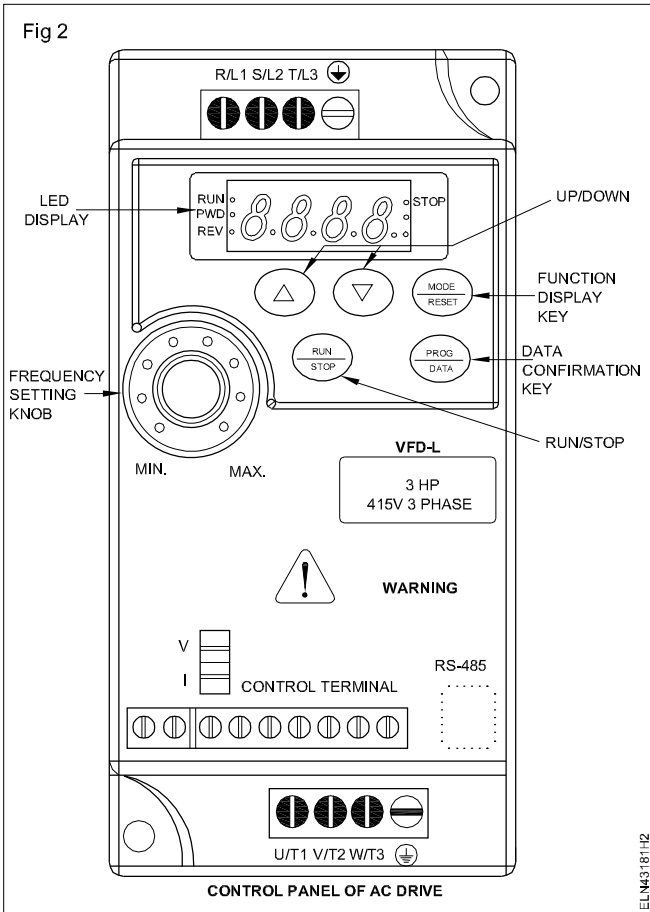

Construct and test a universal motor speed controller using SCR

Objectives : At the end of this exercise you shall be able to

- wire an universal motor speed controller circuit on PCB and test it
- assemble the wired PCB along with POT and socket in a gang box and test
- test the speed controller with lamp, fan, electric drilling machine
- check possible minimum and maximum speed adjustment using contact type tachometer.

Requirements

Tools/Equipments/Instruments

- Trainees tool kit - 1 Set
- Electric hand drilling machine - 1 No.
- Contact type tachometer with necessary attachments - 1 No.
- Wired lamp holder with lamp of 40W or less (Test Lamp) - 1 No.
- Main operated table fan of any make - 1 No.

Materials/Components

- Resistors
 - $R_1 = 10K.5W$ - 1 No.
 - $R_2 = 470 \text{ ohms } \pm 5\%, 1/4W$ - 1 No.
 - $R_3 \text{ \& } R_4 = 1K \text{ ohms } \pm 5\%, 1/4W$ - 2 Nos.
 - Potentiometer (RV_1) = 1K, 1W - 1 No.
- Capacitors
 - $C_1 = 2U2, 63V$ - 1 No.
 - $C_2 = 100 \text{ nf (Polyster)}$ - 1 No.
- Semi-conductors
 - SCR - C106D or equivalent or any SCR of 400V and current rating greater than 3 Amp - 1 No.
 - Q_1 BD135 or equivalent - 1 No.
 - Q_2 BD136 or equivalent - 1 No.
 - (D_1, D_2) IN4004 - 2 Nos.

- Other items
 - PC board code to be made as in Fig 2 - 1 No.
 - 100 x 75 mm gang box used for conduit wiring - 1 No.
 - Hylum sheet 100 x 75mm x 3mm thick - 1 No.
 - Self threading screw 3mm x 10mm for fixing hylum sheet on gang box - 6 Nos.
 - 3mm x 20mm screw and nut (to fix PCB inside the gang box) - 4 Nos.
 - Spacers 3mm x 10mm (to separate PCB from gang box) - 4 Nos.
 - 5Amps, 3 core cable (Mains cord) - 2 m
 - 240V, 6 Amps flush type socket - 1 No.
 - 240V, 6 Amps, flush type SP switch - 1 No.
 - 240V, 6 Amps, 3 pin plug - 1 No.
 - Knob suitable for 16 mm plastic shaft pot - 1 No.
 - Heat sink for SCR (suitable size) - 1 No.
 - Terminal strip 3 way - 1 No.
 - Flexible wire, 5 Amps, 240V (Red, Blue, Green) - 0.5 m each
 - Hookup wire - 1 m
 - Resin core soldering lead - 20 cms

PROCEDURE

- 1 Prepare a PCB for the given dimensions (Fig 1). Check the sizes of the components with the soldering position on the PCB. If necessary slightly alter the dimensions of the PCB track.
- 2 Check the PCB tracks and clean PCB.
- 3 Test the components to confirm its working condition.
- 4 Wire the speed controller circuit on the PCB referring to the circuit schematic in Fig 2 and the PCB layout diagram (Fig 3). Get the wired circuit checked by your instructor.
- 5 Make connections for the POT, switch, 5A flush type socket, mains 3 core cable mains 3-pin top with the wired circuit on PCB by using suitable wires. Get the wiring checked by your instructor.

The wire connections are made is to test the wired speed controller circuit before assembling them in the gang box as in Fig 3. Therefore keep sufficient wire lengths in all connections made for the purpose of safety and ease of testing.

- 6 Test the working of wired circuit by connecting a test lamp load at the output of the speed controller circuit. Check the lamp glow bringing the two extreme positions of the speed.

If the lamp brightness is not varying , vary the position in the wired circuit/connections.

- 7 Test the speed controller using table fan as load and record your observation.

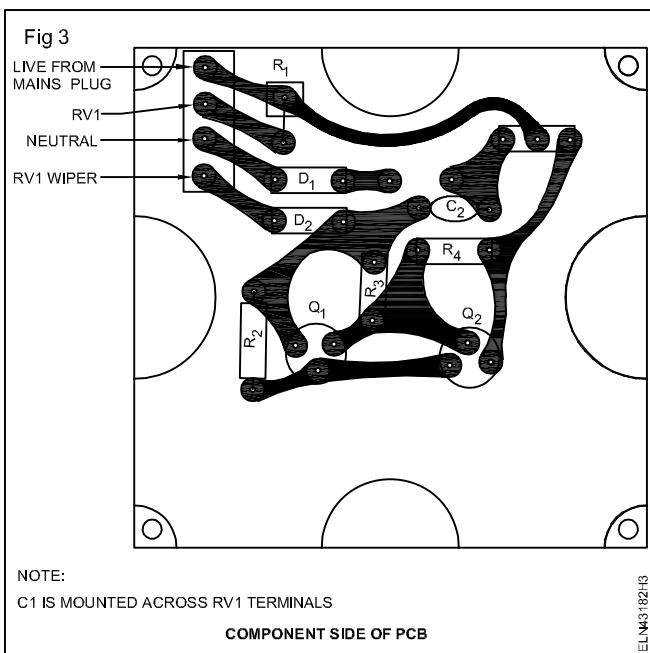
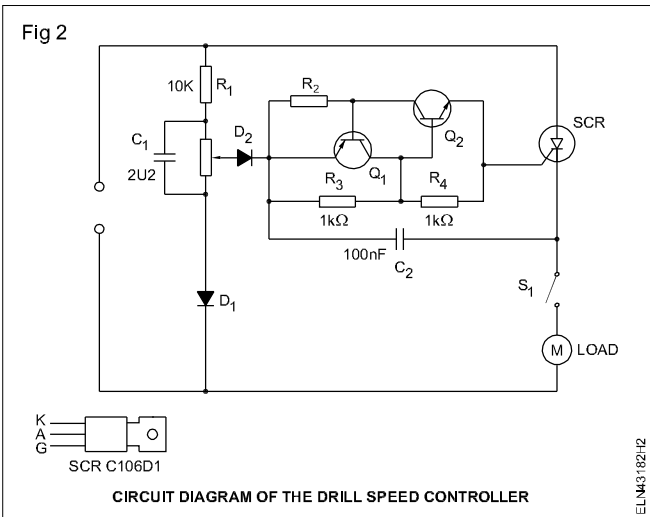
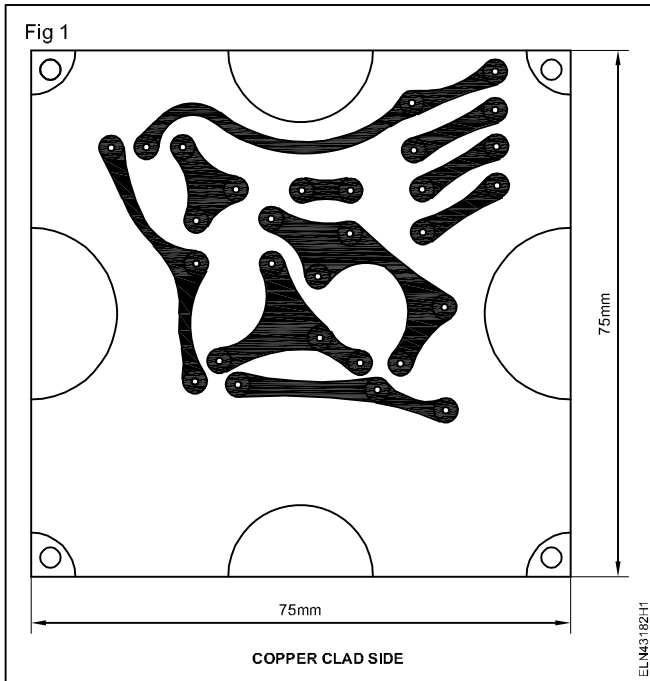

- 8 Assemble the PCB and other associated items, so that the wired speed controller is ready for use as shown in Fig 4. Get it checked by your instructor before fixing the top hylum sheet on the gang box.
- 9 Repeat steps 5 and 6 after making final assembly of the speed controller unit to confirm that no errors are committed during assembly. Record observations made.

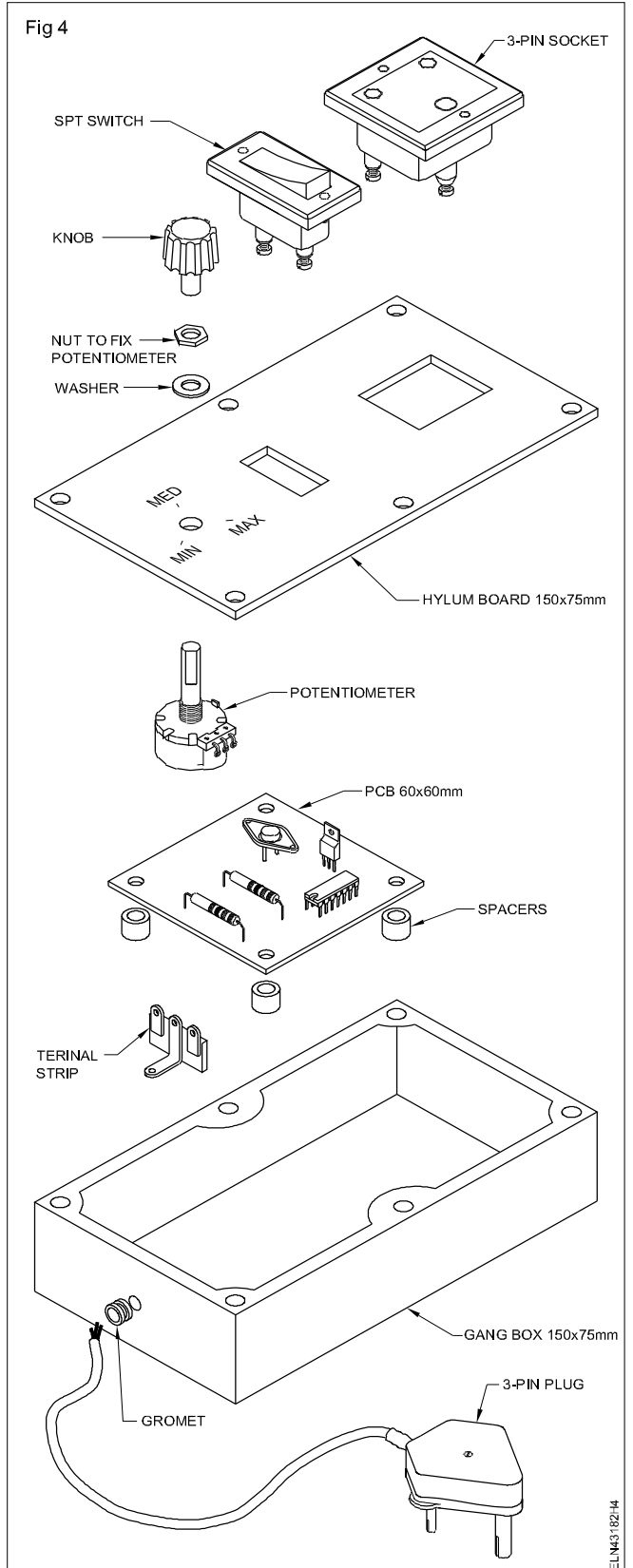

10 Test the universal motor speed controller unit for its range of speed control by connecting an electric drill gun as load and measuring the speed of the gun at minimum, middle and maximum positions of the speed control POT.

11 Record the speed in Table 1. Use contact type tachometer to measure the speed of the electric drill gun at different speed control positions of the POT.

12 Get your work and recorded readings checked by your instructor.

13 Get it checked by your instructor.

The wired and tested universal motor speed controller can be effectively used for any practical applications. So preserve the project work made and use it whenever required.

Table 1

Position POT	Speed in RPM
Minimum	
Middle	
Maximum	

Write the specifications of the wired speed controller on a paper and paste it at the back of the gang box in which the circuit is assembled.

Assemble circuits of voltage stabilizer and UPS

Objectives: At the end of this exercise you shall be able to

- construct voltage stabilizer circuit on PCB
- test the stabilizer for its low and high cut-off ranges
- assemble 'ON' line UPS with assembled PCB modules/circuit boards
- test the 'ON' line UPS for its function.

Requirements

Tools/Instruments

- Trainees tool kit - 1 No.
- Multimeter - 1 No.
- AC Voltmeter 0-300 V - 1 No.
- Variac 0-300V/1A - 1 No.

Materials

- General purpose PCB - 1 No
- Transistors - BC 147/157 - 2 Nos.
- CL 100 - 2 Nos.
- Diode IN 4007 - 2 Nos.
- Zener diode 6V/0.5A - 1 No.
- LED, red & green - 1 No. each
- Inductor - 21 SWG Ferrite core 100 turns - 2 Nos.
- Capacitor - 330 μ Fd/12V - 3 Nos.
- 100 μ Fd/12V - 4 Nos

- Resistors carbon film 1/2 W
1K5, 3K3, 1K - 2 Nos. each
- 560 Ω , 100 Ω - 2 Nos. each
- 4K7, 47K - 3 Nos. each
- 1K Pot - 1 No.
- Electronic relay - 170V - 270 V/6V moulded type : 3 pin - 2 Nos. each
- Buck - boost mains transformer 170V - 270V - 1 KVA - 1 No.
- Assembled modules or PCBs of a ON line UPS - 1 Set
- Incandescent lamps fitted in pendant holders - 1 No.
- Connecting wires/cables - as reqd.
- Solder; flux etc. - as reqd.

PROCEDURE

TASK 1: Construct voltage stabilizer circuit on PCB

- 1 Solder the components on general purpose PCB as per the circuit (Fig 1). Do not fix the transformer on PCB.
- 2 Connect the wires or cables from the PCB to connect with transformer winding terminals.

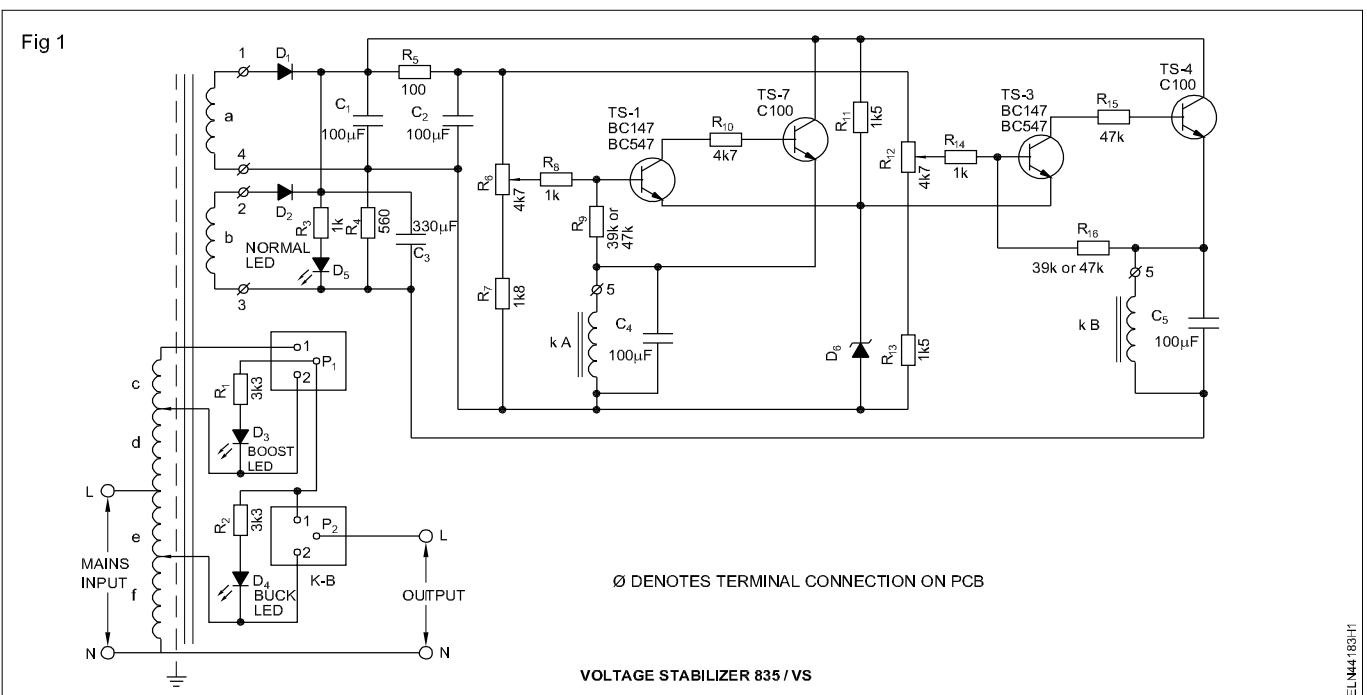

- Finish the wiring and clean the PCB; check the wiring for its correctness.
- Connect the transformer input wires to the Variac for testing the circuit. Connect the incandescent lamp in the output of stabilizer. (Fig 2)

- Switch 'ON' the supply to Variac and slowly increase the voltage till normal LED glow and output lamp glow.
- Switch 'OFF', remove the lamp and connect the voltmeters. Do not change the variac position.

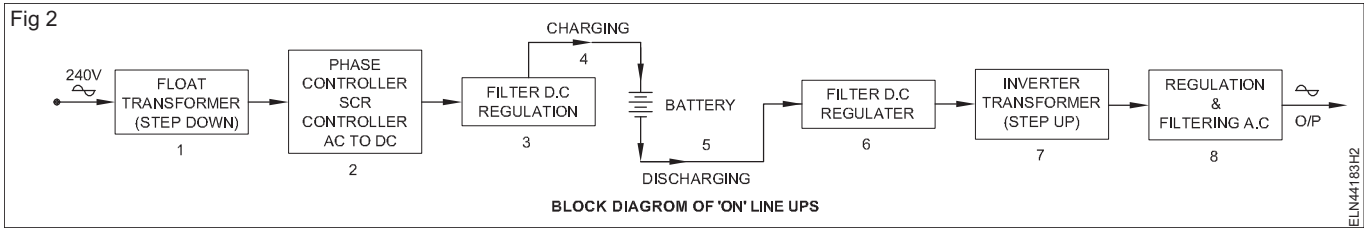

- Switch 'ON' the supply and note down the voltage in Table 1.
- Test the bulk-boost action by increasing and decreasing of Variac voltage increase the variac voltage.
- Check the voltmeter, starts to show increase in voltage initially; but drops to normal voltage. Note down both the voltage; Voltage in output and Voltage at Variac terminals. Record in the Table 1.

- Reduce the voltage of Variac and note the voltmeter reading. The voltmeter voltage will decrease but regains its normal position.
- Note this time voltage : Voltage at output and variac terminal voltage in the Table 1.

If the voltage is not changing when changing variac volt ; consult your instructor.

- Remove all connections and get your voltage readings approved by your instructor.

Table 1

SI. No.	Variac voltage position	Variac terminal voltage (Volt)	Output voltage (Volt)
1	Variac knob in Middle Position		
2	Increase from Middle Position		
3	Decrease from Middle Position		

TASK 2: Assemble of 'ON' line UPS using wired PCB modules

- Refer the block diagram in Fig 2 and arrange the PCB wired modules.
- Wire the PCB modules as per the block diagram in Fig 2 and check the sequence as per the Fig 3.

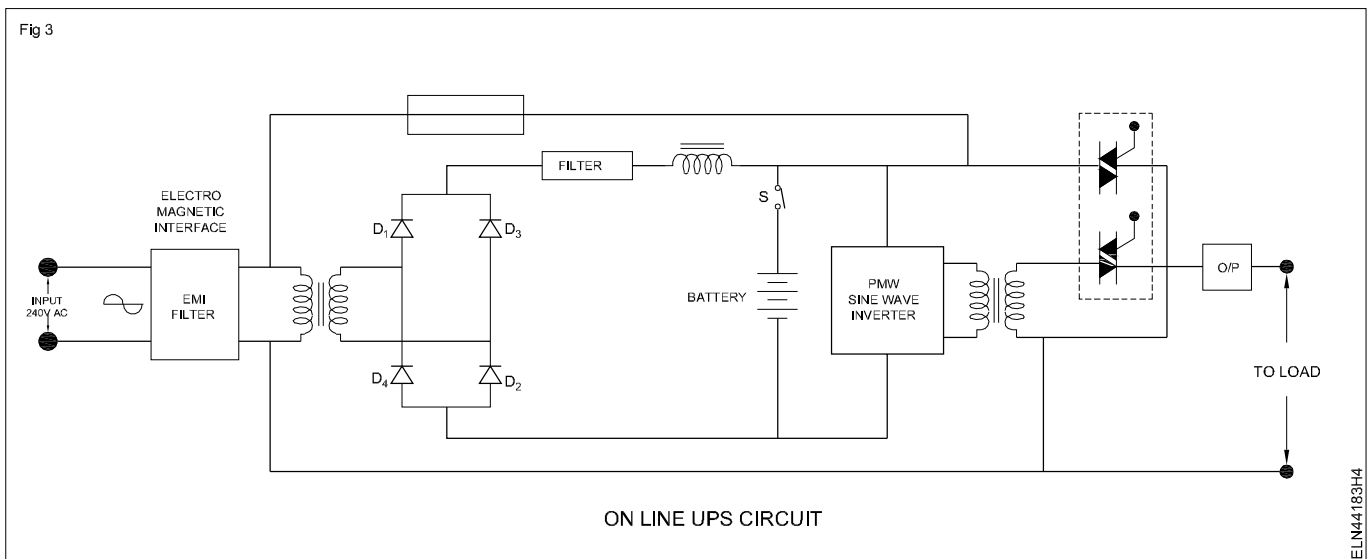

- Connect the charged battery without shorting the battery terminals. Connect one single pole switches initially with battery circuit.

- Connect the input to EMI filter. Check for any circuit problems. Switch 'ON' the circuit 240V AC. Check the output with Voltmeters. Record the meter reading in Table 2.

If it is not indicating any voltage and consult with your Instructor.

- 5 Switch 'ON' the battery. Check the voltage in the output and record the reading in Table 2.
- 6 Switch 'OFF' the Mains 240V and check the voltage in output, record the voltage in Table 2.

If no voltage consult with your instructor.

- 7 Connect the incandescent lamp in the output. Repeat steps 4 to 6.

- 8 Note the lamp brighten while input supply 220V. Switched 'ON' & 'OFF'.

If lamp is not glowing or dim consult with your Instructor.

- 9 Get your readings approved by your instructor.

Table 2

Sl. No.	Input supply voltage	Output voltage (Volt)
1	'ON'	
2	'OFF'	

Prepare an emergency light

Objectives: At the end of this exercise you shall be able to

- assemble the components on the PCB and construct charging circuit for battery
- assemble inverter circuit for emergency light
- assemble charging circuit and inverter circuit for emergency light.

Requirements

Tools/Instruments

- Soldering iron 10W, 240V - 1 No.
- Wire stripper 150mm - 1 No.
- Tweezer 150mm - 1 No.
- Insulated round nose plier 150mm - 1 No.
- Insulated wire cutter 150mm - 1 No.
- Multimeter - 1 No.

Materials

- Step down transformer centre tapped 240/7.5-0-7.5V, 2A - 1 No.
- Rectifier diode in 5402 - 3 Nos.
- Lead acid battery 6V, 10Ah, maintenance free type - 1 No.
- Toggle switch 2A, 240V SPST - 1 No.
- Toggle switch 2A, 240 DPST - 1 No.
- Relay 6V DC, 5A with one 'NO' and one 'NC' - 1 No.
- Fuse unit with fuse 0.5A (glass type) - 1 No.
- Fuse unit with fuse 2.5A (glass type) - 1 No.
- LED holder 5mm - 2 Nos.
- LED 5mm red - 1 No.
- LED 5mm green - 1 No.

- Resistance 1K, 1/4W - 1 No.
- Resistance 2.2K, 5 W - 2 Nos.
- Resistance 2.2 Ω 1/4 W - 1 No.
- Capacitor 10 μF, 25V - 1 No.
- Capacitor 1000 μF, 25V - 1 No.
- Soldering flux - 10 gms
- Soft solder 60% lead and 40% Tin - 50 gms
- General purpose PCB 150mm x 100mm - 1 No.
- PVC insulated tinned copper cable 14/0.38 mm - as reqd.
- P.V.C. Insulation tape 20mm, 10m - 1 roll
- Screw type incandescent lamp 6V 15W - 1 No.
- Transistor 2N 3055 with the heat sink - 1 No.
- Resistance 50Ω, 5W - 1 No.
- Capacitor 2.2 μF, 250V - 1 No.
- Inverter transformer 6V, 20W - 1 No.
- Complete fluorescent tube light fitting with 20W tube in suitable sheet metal box - 1 Set
- Silicon grease - 5 gms

PROCEDURE

TASK 1 : Construct charging circuit for emergency light

- 1 Draw the circuit diagram (Fig 1) of a simple emergency light circuit.
- 2 Identify each component in the circuit.
- 3 Test the collected components for their condition.
- 4 Arrange the components except the battery on the PCB to meet the technical requirement and aesthetic sense.
- 5 Draw the layout of the components of the PCB.
- 6 Mount the components on the PCB in the respective places.
- 7 Solder the components as per Fig 1.
- 8 Check the connection as per circuit diagram.
- 9 Switch 'ON' the AC supply for charging the battery.
- 10 Check the glow of red LED which is an indication for the presence of AC supply.
- 11 After charging the battery switch 'OFF' the AC supply, put 'ON' the lamp and observe the functioning of the emergency light and also check the indicator green LED is 'ON'.

Do not allow the emergency light battery to discharge fully.

While soldering the components ascertain correct polarity.

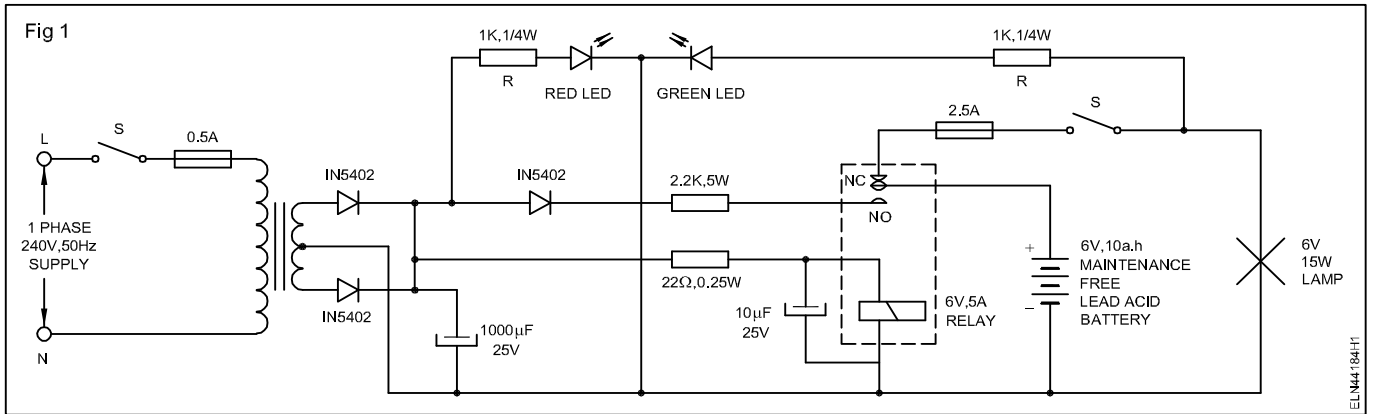

TASK 2 : Construct inverter circuit for emergency light

- 1 Trace the circuit diagram of an emergency tube light circuit as per diagram. (Fig 2 and 3)
- 2 Identify the each component of the circuit.
- 3 Solder the components on PCB for making inverter circuit. (Fig 3)
- 4 Mark the inverter circuit board with charging circuit. (Fig 2)
- 5 Test the emergency light after connecting fluorescent tube light.
- 6 Fix permanently the charging unit, inverter and fluorescent tube suitably in a box/case.
- 7 Check the indicating LED Red and Green functioning correctly.
- 8 Get the work checked and approved by instructor.

Inverter circuit preferably to be assemble in a separate small PCB

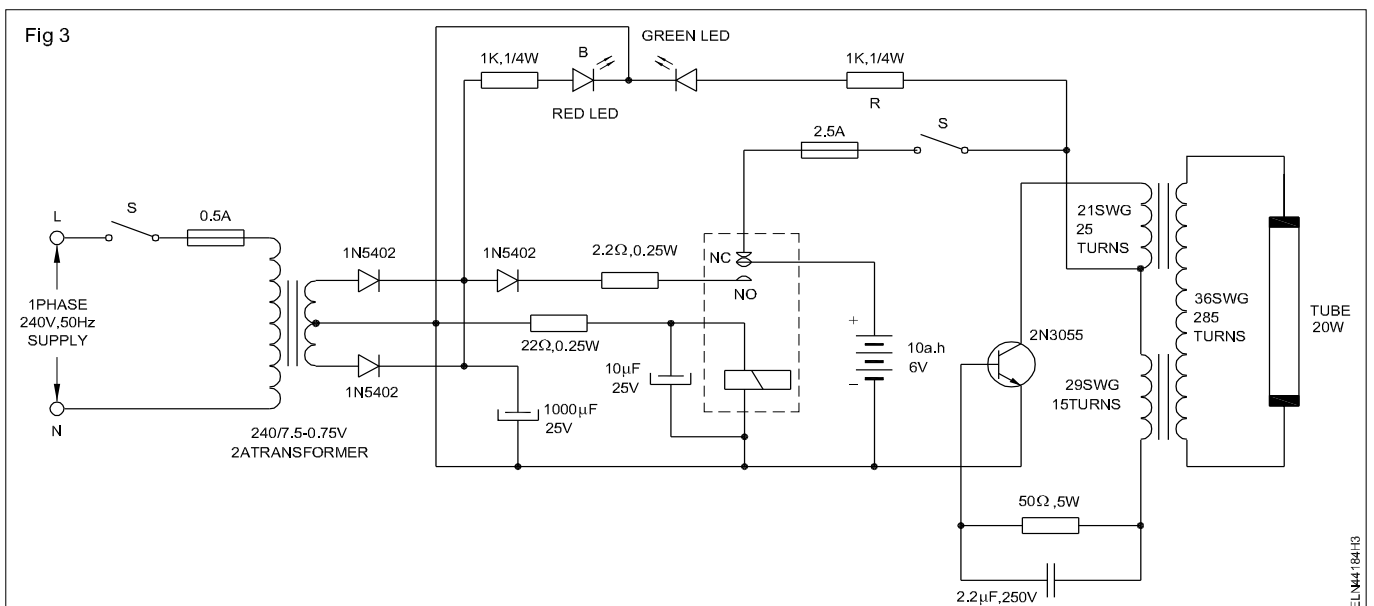
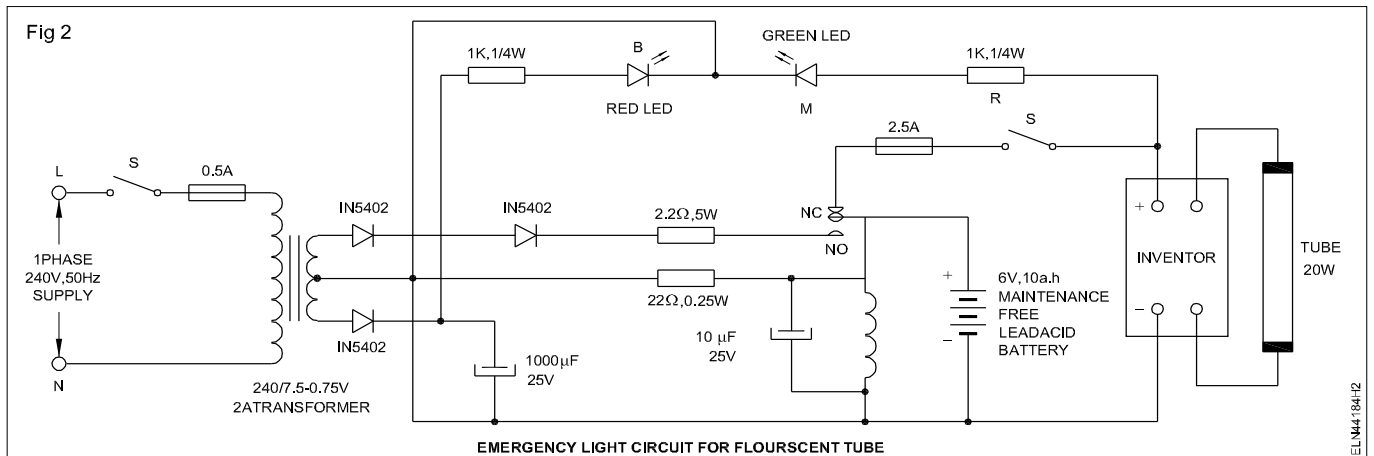

Assemble circuits of battery charger and inverter

Objectives: At the end of this exercise you shall be able to

- assemble the battery charging circuit wired on PCB and test it
- construct and test inverter.

Requirements

Tools/Instruments

- Trainees tool kit - 1 Set
- soldering iron 35W/250V - 1 No.
- De soldering gun 65W/250V - 1 No.
- Star screw driver set (set of 6 Nos) - 1 Set
- Ammeter 0-10 A M.C - 1 No.
- Voltmeter 0-50V M.C - 1 No.
- Digital multimeter (31/2 digits) - 1 No.

Equipments/Machinery

- Auto transformer 0-270 V-5A - 1 No.
- Step down transformer 240/40V, 300VA - 1 No.
- Charger transformer with centre tapping 6V-0-6V,500mA - 1 No.
- Sealed maintenance Free battery 6V/120AH - 1 No.
- Relays double pole - 3 Nos.

Materials/Components

- PCB -115-General purpose - 2 Nos.
- Push button switches - 2 Nos.
- Toggle switches 250V/6A - 2 Nos.
- Diodes 1N4002 - 4 Nos.

- Diodes for bridge 1N112 - 4 Nos.
- Capacitors -250mfd/12V - 1.No.
- Resistors,10Ω, 1W - 1 No.
- Pot 1.5Ω/10W - 1 No.
- Low voltage lamp 6.3V - 1 No.
- Fuse 250 mA - 3 Nos.
- Neon lamp - 1 No.
- Buzzer 250V - 1 No.
- Soldering flux and 60/40 solder - as reqd.
- Diode IN 5402 - 3 Nos.
- LED : Red and Green - 1 No.
- Transistor - 2N 3055 - 1 No.
- Resistor : 2.2Ω, 22Ω, 50Ω, 1K (1 Watt) - 1 No. each - 2 Nos.
- Electrolytic capacitors 1000 μfd/25V, 10 μfd, 25V - 2Nos. each
- 2.2 μfd/250V - 1 No.
- Relay NC/No 6V - 1 No.
- Transformer 240V/7.5 - 0 - 75V, 2A - 1 No.
- Inverter transformer- iron core laminated 21 SWG - 25 turns, 29 SWG - 15 turns - Primary 36 SWG - 285 turns - Secondary - 1 No.
- Fuse 2.5A, 0.5A - 1 No. each
- SP Switches (Toggle - 6V) - 2 Nos.

PROCEDURE

TASK1 : Assemble the battery charging circuit

- 1 Select suitable PCB (wired PCB)and other components
- 2 Check all components ie. transformer, relays, battery for their good condition
- 3 Construct the transformers relays, and other components on PCB. (Fig 1)
- 4 Connect the charger Transformer (X1)to the auto transformer (X2).
- 5 Connect the secondary of charger transformer (X1) to the full wave bridge rectifier which supplies rectified voltage to the battery under charge through ammeter, voltmeter and potentiometer.

- 6 Connect the pole (P1) of relay (RL1)to A.C main supply and connect pole (P2) is cut off circuit.
- 7 Connect the poles (P1 & P2) to normally open (N/O) pin, which will switch 'OFF' AC Main supply to the circuit.
- 8 Connect the test switch (S3) to check battery polarity.

Reset switch (S4) is used to reset the charger, when any fault occurs and the charger is cut off. The switch (S1) for ON/OFF.

- 9 Connect the ON/OFF switch (S1) to the input of AC main supply.

Step down transformer (X3) keeps the cut off relay in energised condition when the main AC supply is cut off to the charger circuit. Relay (RL1) is used to cut off the AC main supply to the charger circuit.

Normally a fully charged lead acid battery voltage 2.1 V/cell, During on charge ,and can be increased up to 2.7 V/cell .The voltage of a battery is multiple of the number of cells in that battery .The voltage on Fully discharged condition is 1.8 V.

- 10 Connect the diodes neon lamps, fuses, capacitor, resistor, buzzer, low voltage lamp in correct position as in the circuit.
- 11 Solder all PCB connection neatly and clean the PCB, without making any short circuit.
- 12 Set the auto transformer (X2) is in zero level position, before charging the battery.
- 13 Keep the switches S1,S2 & S5 on open position .
- 14 Connect the battery to the charger output terminal (positive terminal to the battery positive pole and negative terminal to the battery negative pole)and close the switch S3.
- 15 Check the readings in voltmeter which is connected through diode D9 and switch S3.

If the battery is connected in wrong/reverse polarity, then the diode will block the battery voltage and no reading in voltmeter. Correct the battery polarity by charging the connection to read the volt meter.

- 17 Vary the setting of Auto transformer slowly from zero position until the voltmeter shows the reading nearer to the voltage of battery to be charged.
- 18 Switch 'ON' the charging switch (S2) and increase the voltage by varying auto transformer till, the required charging current (5 Amp) is displayed by the ammeter.
- 19 Leave the charger on to charge the battery to the required level.

If the battery is fully charged automatic cut-off circuit will switch 'OFF' the supply to the battery, and automatically switch 'OFF' the charging current which flows through potentiometer VR1, to cut off relay RL1.

When the battery is fully charged the current through the potentiometer increases and relay RL1 is energised through diode D7 and D8, and the pole of relay RL1 (ca) is connected to N/O contact which will cut off main A.C supply to auto transformer X2 and switch on the error indicator buzzer and the warning neon 'N2' lamp.

- 16 Close the main ON/OFF switch (S1) by keeping the zero position of an autotransformer (X2) and neon lamp (N1) and Lamp (L1) will indicate 'ON'.

- 20 Switch 'OFF' the buzzer by the switch (S5).

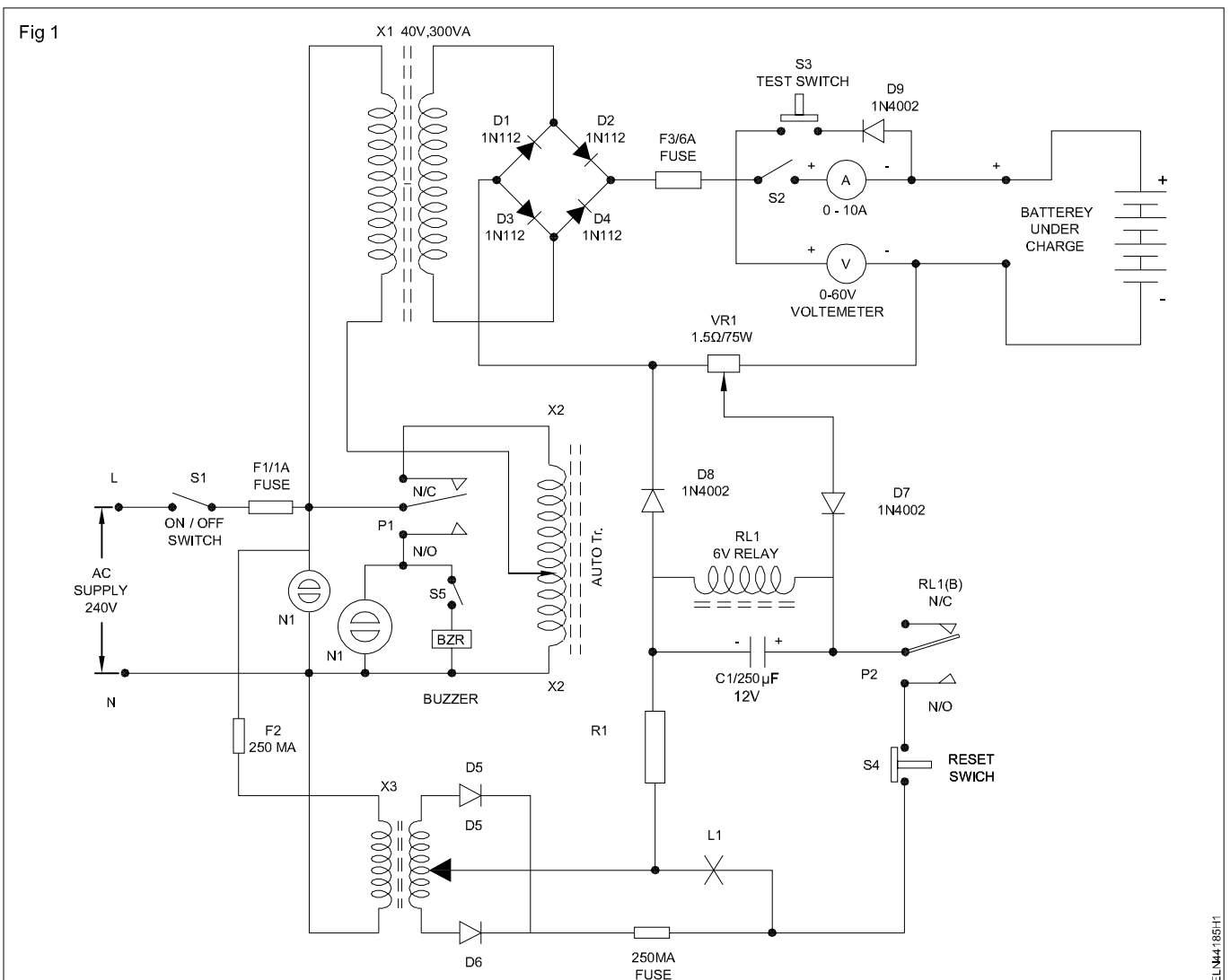

Test analyse, defects and repair voltage stabilizer, emergency light and UPS

Objectives: At the end of this exercise you shall be able to

- analyse the defect and repair voltage stabilizer
- repair and maintenance of emergency light
- analyse the fault and repair the defects in UPS.

Requirements			
Tools/Instruments			
• Trainees Tool kit	- 1 Set	• CRO 20 MHz/dual trace	- 1 No.
• Connector screw driver set	- 1 Set	• Assembled circuit of voltage stabilizer in Ex. No. 4.4.183	
• Line /Neon tester 500 V	- 1 No.	• Assembled circuit of emergency light in Ex. No. 4.4.184	
• Soldering iron 35 W/250V	- 1 No.	• Assembled circuit of 'ON Line' UPS in Ex. No. 4.4.183	
• Desoldering gun	- 1 No.		
• Multimeter (analog (or) digital)	- 1 No.		
• Clamp on meter	- 1 No.		
Equipments		Materials/Components	
• Common UPS 625 VA/12 V	- 1 No.	• Spare components	- as reqd.
• Sealed lead acid battery with operation manual (maintenance free battery) 12V/120AH	- 1 No.	• Solder 60/40	- as reqd.
		• Soldering flux	- as reqd.
		• Connecting wires	- as reqd.

PROCEDURE

TASK 1: Analyse the fault and repair of voltage stabilizer with the help of a Service Flow Sequence (SFS)

- 1 Check the circuit carefully before connecting the supply for any short circuit in the components/parts in the stabilizer.
- 2 Connect the main supply cable into ohm meter and check the resistance by switch 'ON' the circuit (note to be connect with AC mains)

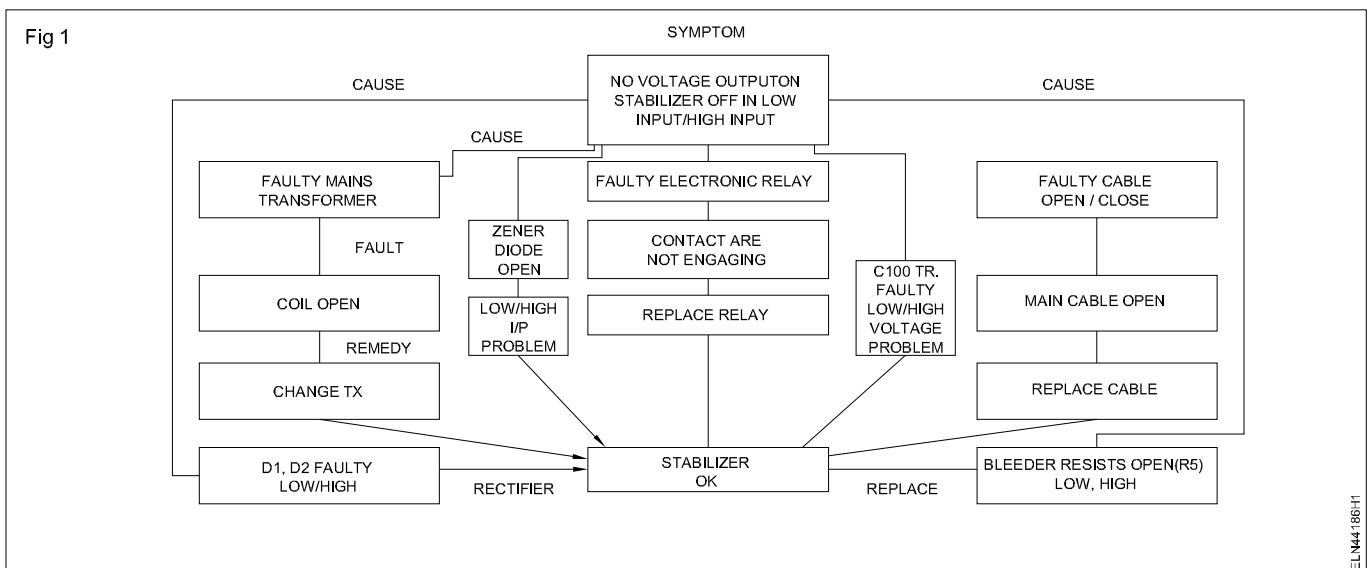

If it shows '0' resistance, it indicates a dead short. Consult your instructor.

If the meter shows infinity i.e. open circuit. Otherwise, if it is a healthy circuit it will show some resistance reading.

- 3 Check for any open circuit visually or by ohm meter after testing for short circuit.
- 4 Analyze the status of the circuit by the meters reading.

5 If the stabilizer is without short circuit fault, connect it to the supply mains and switch 'ON'. Check the

symptoms of the unit, and record the symptoms. Analyze the fault with the help of service flow sequence.

TASK 2: Repair and maintenance of emergency light with the help of trouble shooting sequence block

1 Steps 1 to 5 on as same as follow in Task 1 . Refer the service flow sequence diagram (Fig 2) and solve it.

There may be single fault or multi fault involving more components. A visual check will help in to find burning of components, dry soldering, loose connection, etc. A careful visual check is very much essential.

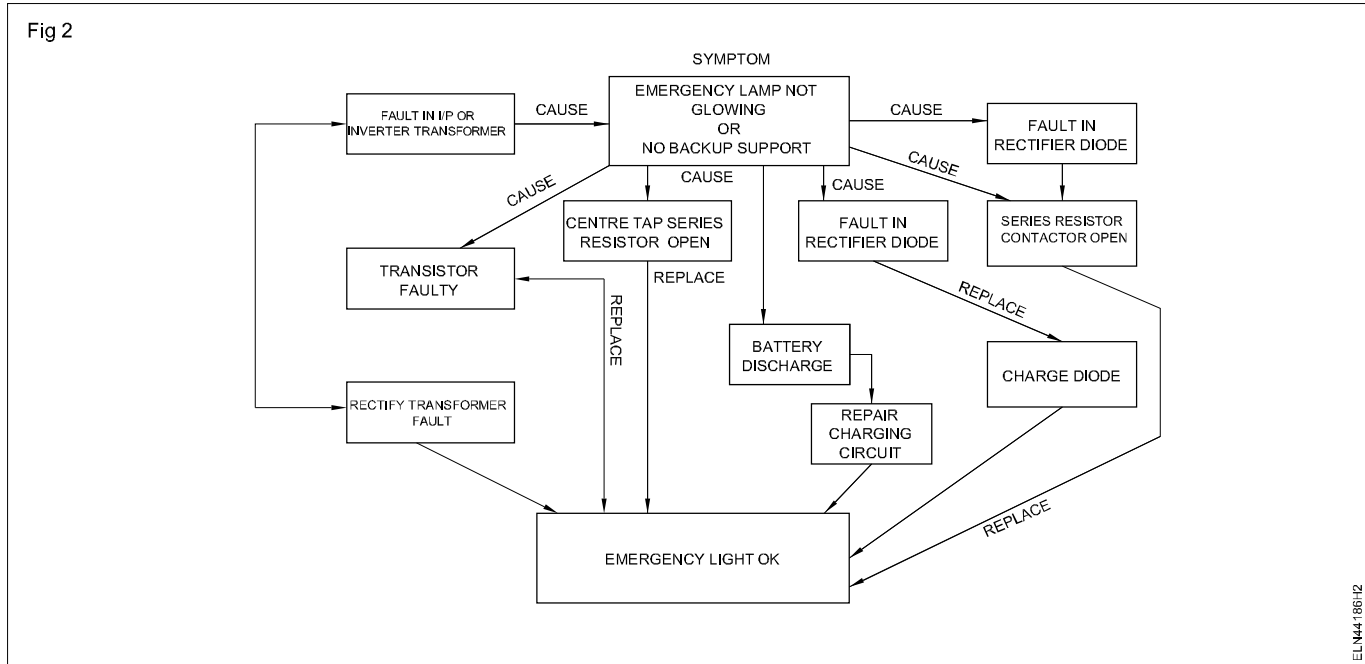

TASK 3 : Test UPS and identify the faults and rectify

1 Read and interpret the name plate details of the given UPS

Type of UPS.....ON line/OFF line

Model

Power ratingVA

Change over timem sec

Battery rating

Back up timeHours

- 2 Switch 'ON' the UPS, with UPS. 'Plugged in'
- 3 Press and hold the ON/OFF /test /silence button for more than one second until "Line normal 'LED green lights up. (i.e U.P.S .'ON' and ready for use)

If green LED does not light up, the possible causes may be (i) button not pressed (or) pressed to short (ii) voltage of battery less than 10V (iii) PCB - failure and (iv) load may be less than 20 W at battery mode.

4 Identify the problem by self testing UPS., and rectify this fault by referring the trouble shoot sequence block diagram (Fig 3)

5 To switch 'OFF' the UPS press and hold the ON/OFF/ test/ silence button for more than 3 seconds until the "Line normal" or "backup" LED 'OFF'.

6 Check the condition of switch, (or) back up LED (yellow LED) (or) press the switch for more than 3 seconds and rectify the problem, if the UPS not switched 'OFF'.

To de-energise the UPS properly in emergency, the right way is to switch 'OFF' the output switch to 'OFF' position and disconnect the power cord from the main supply.

7 Press the ON/OFF/test/silence switch, more than 3 seconds, to switch 'OFF' the UPS and battery.

8 Check the back up (LED yellow).

If the yellow LED (back up) lights 'OFF', the UPS and battery is on 'OFF' position. If the back LED is not 'OFF', it indicates UPS always at battery mode. The causes for this fault may in power cord, fuse or up normal voltage.

- 9 Check the condition of power cord, A.C fuse, abnormal voltage and PCB.
- 10 Rectify problem by referring the trouble shooting sequence block diagram (Fig 4)

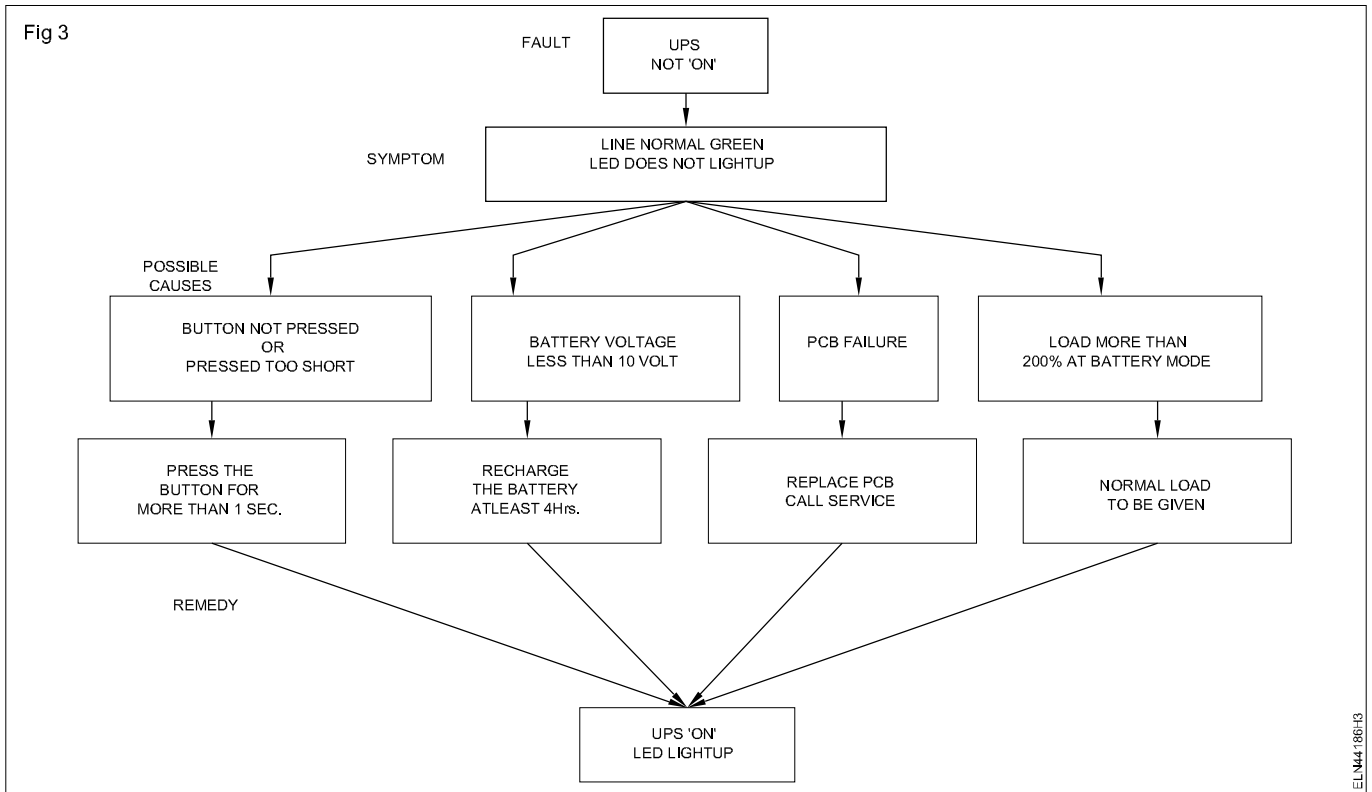

ELN44186F3

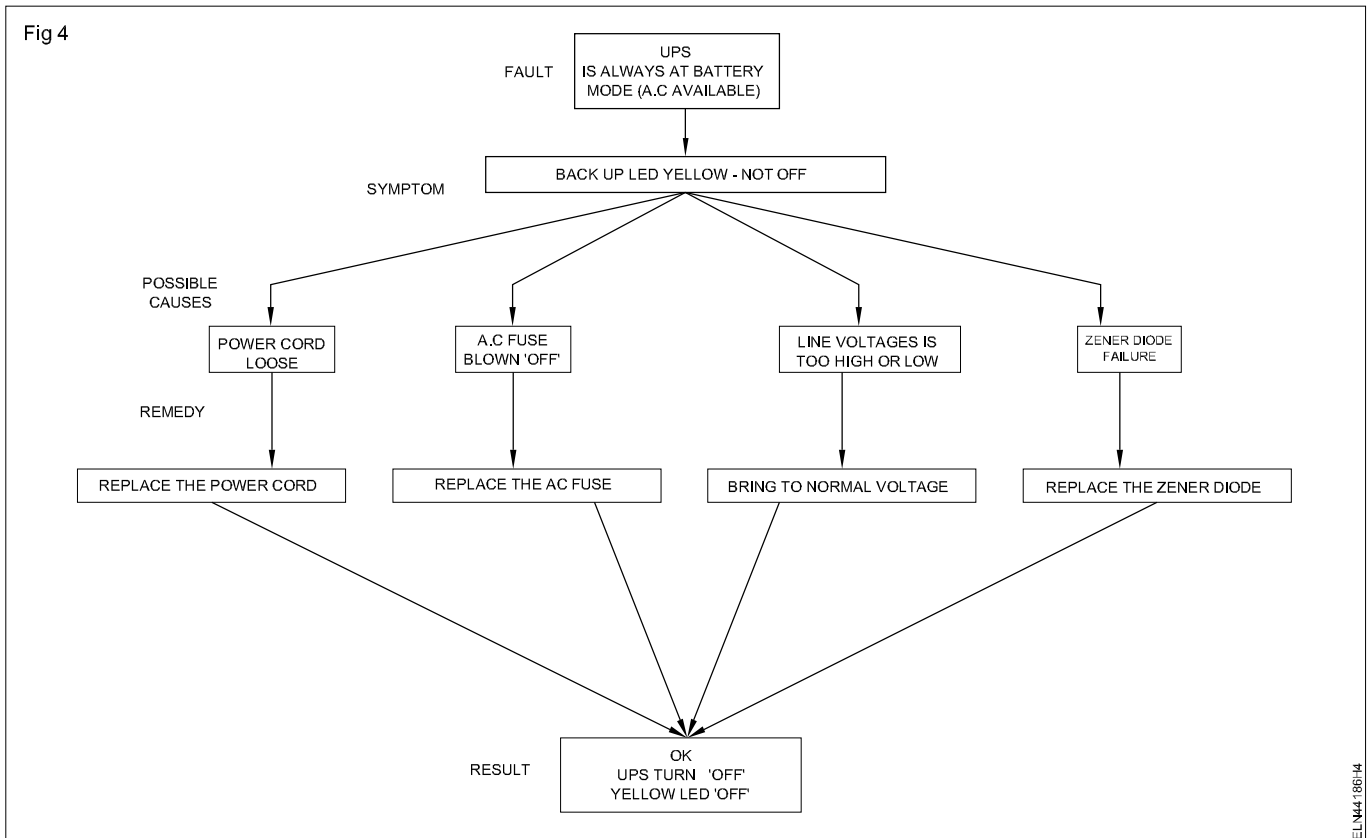

ELN44186F4

- 11 Press the ON/OFF/TEST silence button less than one second, when A.C mains supply is available observe the operation UPS

If the UPS operates on load on battery mode, then battery LED lights up, it indicates UPS is in 'ON' line operation.

If the UPS does not operate on load on battery mode and immediately returns to 'ON' line operation and lights up the RED-LED ,It indicates that the back up time is too short the battery is to be replaced (or) to be recharged.

- 12 Recharge the battery immediately for atleast four hours.
13 Check and test UPS with recharged battery and rectify the fault by referring Fig 5, Trouble shooting sequence block diagram.

If the "replace battery" (red LED) is still on, replace the battery.

- 14 Press the ON/OFF/test/silence button for less than 1 sec in 'Backup' mode ,observe the audible alarm, It should be 'silence.

If does not function under 'Low battery (or) over load conditions.

- 15 Check the beeping alarm ,when pressing the silence button to stop the operation of UPS.

Fig 5

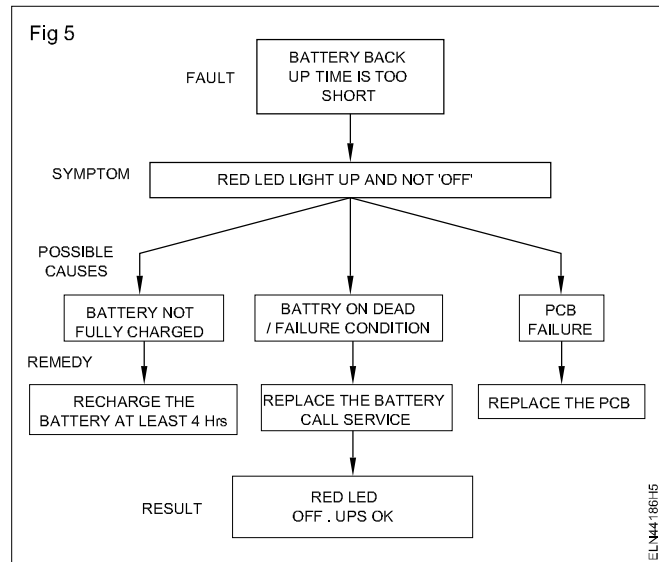

If it is stopped in back up mode it indicates UPS is in normal . But, If the beep sound alarms continuing, It indicates that UPS is over loaded.

- 16 Press the button (ON/OFF)during alarms to stop the beeping when yellow LED (backup) lights up.
17 Check for the maximum connected load to UPS and rectify this fault by disconnect the excess until the beep alarm is not available.

TASK 4 : Replacement of battery

Follow the instruction and procedure below for easy battery replacement

- 1 Unplug unit from AC power source and disconnect all connected equipments /load
- 2 Disconnect AC power cord from UPS unit
- 3 Turn the unit upside down and unscrew the 4 screws on top of the battery.
- 4 Keep the screws in a safe place for re assembling
- 5 Turn the entire unit right side up, by holding the top firmly
- 6 Lift top cover off and place to the side.

The connection and electronics components will be exposed. Do not touch an inner components when changing the battery.

- 7 Disconnect and remove the two leads (red & black)from the battery.

- 8 Remove the battery from the unit easily.

Cautions:

- Do not dispose of battery in fire
- Do not attempt to open the battery
- Use tools with insulated handles
- Remove watches rings etc while charging the battery

- 9 Place the new battery in the same position (or) direction as the old one.
- 10 Reconnect the leads (ie) read lead to positive (+ve) position and black lead negative (-ve)position.
- 11 Reconnect the equipment properly by following the steps 6,5 and 3 (in that order)
- 12 Check the unit for its good condition and performance.

Maintain service and troubleshoot battery charger and inverter

Objectives: At the end of this exercise you shall be able to

- carryout service and troubleshoot a battery charger
- troubleshoot and repair a inverter.

Requirements		
Tools/Equipments		Material
<ul style="list-style-type: none"> • Trainees kit • Multimeter 	<ul style="list-style-type: none"> - 1 No. - 1 No. 	<ul style="list-style-type: none"> • Collect the circuits already constructed in Ex.No. 4.4.185

PROCEDURE

TASK 1: Service and troubleshoot of battery charger

- 1 Trace the battery charger circuit made in Ex.4.4.185 as in Fig 1.
- 2 Check the circuit for an availability of charging volt at battery connecting terminals.

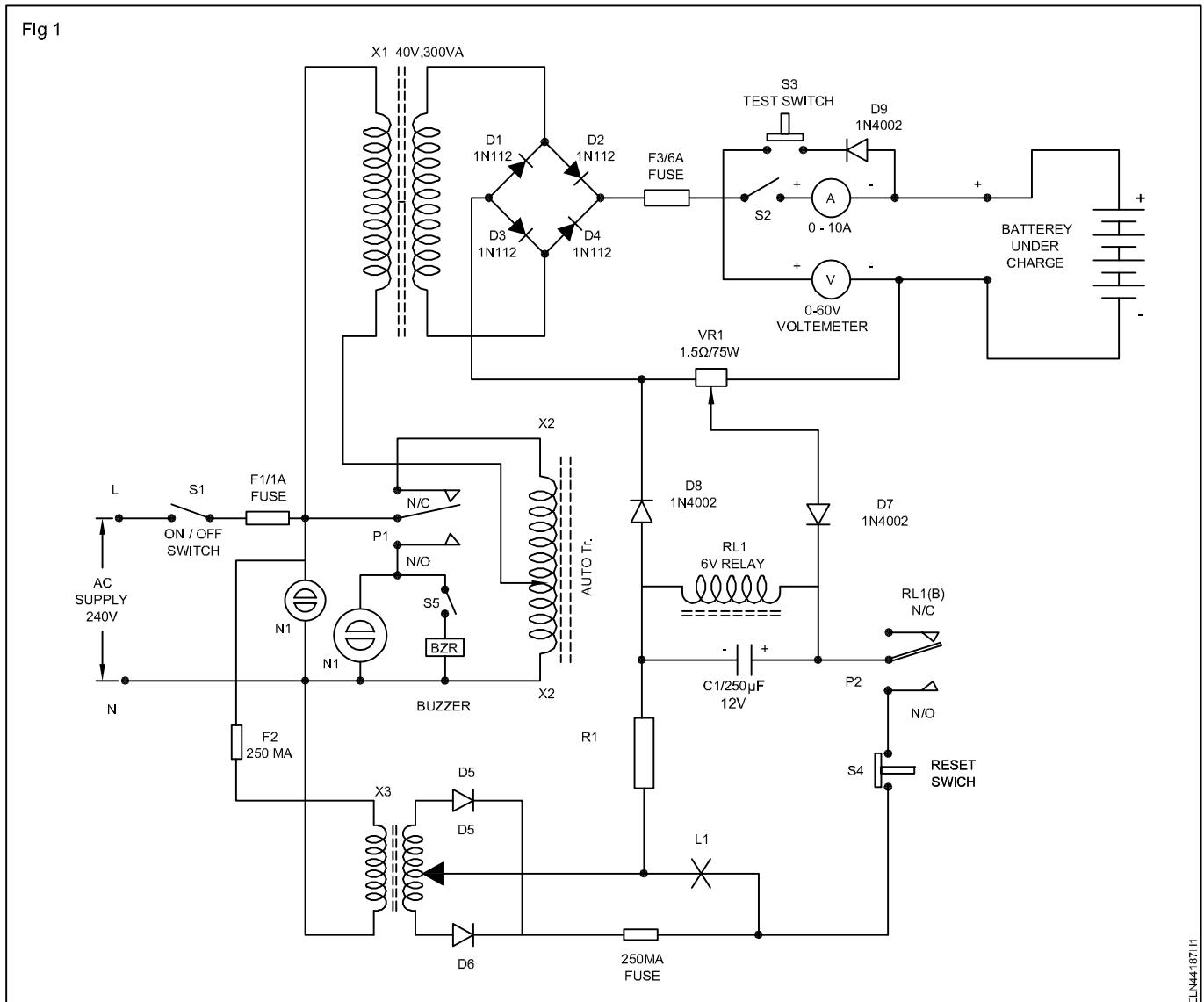

- 3 Check the fuse provided in the fuse carrier. If the voltage is not available.
- 4 Test the voltage output at the bridge rectifier output with multimeter.
- 5 Check the conditions of bridge rectifies diodes if found defective replace. If no voltage available.
- 6 Check the AC input to Bridge network. If the diodes are OK.
- 7 Check the relay contacts and; ensure supply is available at primary of the auto transformer. If the AC is not available
- 8 Check the charging control circuit for normal working after the charging circuit is repaired.
- 9 Check that auto cut-off of AC Mains is 'OFF' the battery is fully charged.

- 10 Check the diode connected to potentiometer and voltage at relay terminals, If auto cut-off is not working or functioning, and if the voltage is present at relay terminal (pole) Auto cut-off is OK.
- 11 Check the conditions of the battery, fully charged battery will show DC Voltage in no load about 20% more than the rated voltage.

Do not allow the battery Voltage (no-load) drop below 70% of the rated voltage. If it is so revival of the battery is difficult.

- 12 Check while charging battery; ensure that it is topped-up with distilled water and caps are removed for easy gaseous out from the cells.
- 13 Complete the work and show to your instructor for approval.

TASK 2: Service and troubleshoot of inverter circuit

- 1 Trace the circuit made in Ex. No.4.4.185 (Inverter circuit) and locate the Active Components. (Fig 2)
- 2 Carry out short circuit and open circuit test.

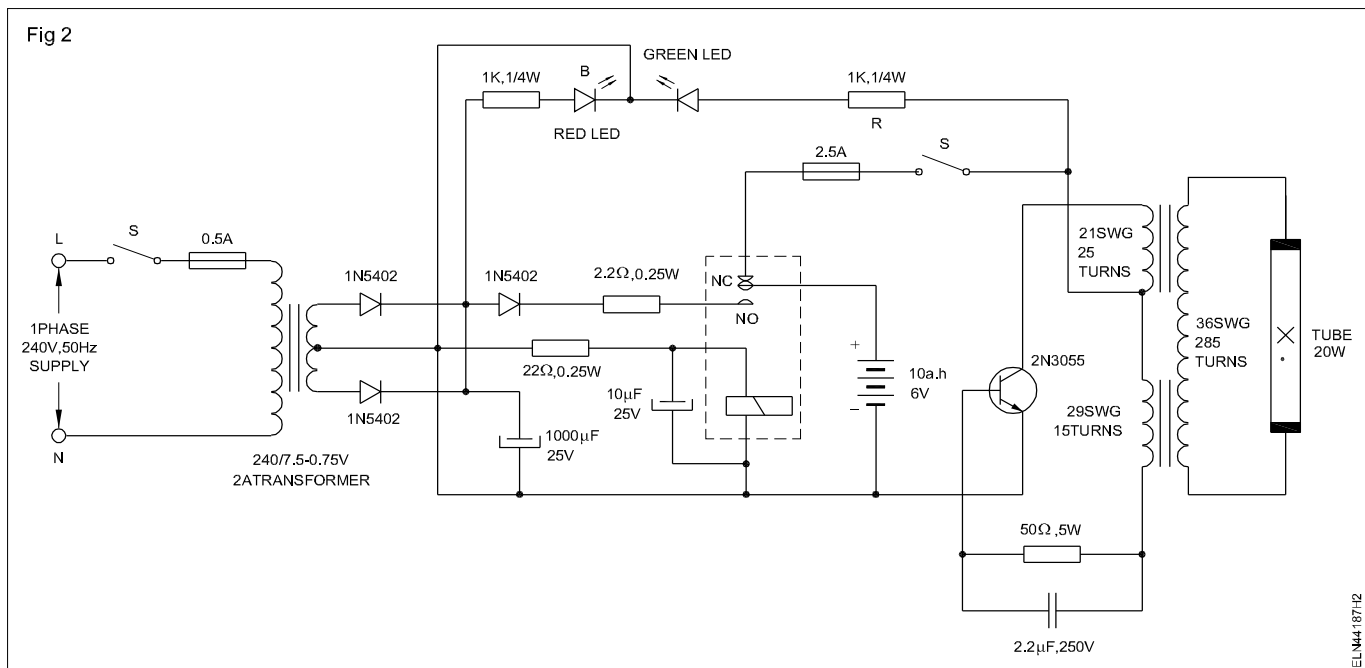

- 3 Remove the battery connect to AC Voltage check the inverter output with mains 'ON'.
- 4 Check the continuity of inverter transformer primary and secondary windings. If then is no output.
- 5 Check the transistor 2N3055 and the base supply. If the transformer is OK,
- 6 Check the fuse provided with NC of relay and check the conditions of relay contacts.
- 7 Check the rectifier diodes and bleeder resistor connections secondary to the Mains transformer.

- 8 Check the mains transformer primary and secondary windings. Check the main fuse.
- 9 Once the repair is completed check the output voltage without battery connections.
- 10 Connect the charged battery if output is available and operate it and ensure its working. Maintenance of battery is explained in the Task 1 and follow the same.
- 11 Complete the work and show to your instructor for approval.

Install an inverter with battery and connect it in domestic wiring for operation

Objectives: At the end of this exercise you shall be able to

- **select the proper rating of inverter to install**
- **select suitable place for the inverter in the house**
- **select a correct rating of battery and the place to keep with inverter**
- **install the inverter and make connection to the load**
- **test the inverter for its good performance in 'OFF' and 'ON' supply mains.**

Requirements			
Tools/Instruments		Materials/Components	
• Trainees kit	- 1 Set	• 4 way MCB -20A	- 1 No.
• Portable electric drilling machine 6mm	- 1 No	• 1.5mm ² P.V.C. copper (1/18)wires	- as reqd.
• Star head screw driver set (set of 6mm)	- 1 No.	• Auto wires (stranded)	- as reqd.
• Rawl jumper No.8	- 1 No.	• I.C.D.P switch 16A/250V	- 1 No.
• Cutting plier 150mm	- 1 No.	• 4 way MCB/ICDP20 A switch	- 1 No
• D.E spanner set 6mm-25mm	- 1 Set	• Power socket 250 V/16A	- 1 No
• Ballpein hammer 0.75 kg	- 1 No	• Multi pin wall socket 250V/6A (2 in one)with switch	- 1 No
• Single phase energy meter 250V/15A	- 1 No	• Grease/Vaseline	- as reqd.
• Multi pin socket 3/5 pin 250V/6A	- 1 No.		
Equipments/Machinery			
• 200W/250V/6A-inverter	- 1 No.		
• Battery 12V/120AH	- 1 No.		

PROCEDURE

TASK 1: Select, install inverter with battery to connect in domestic wiring

- 1 Select the suitable rating of the Inverter considering the total connected load in that house, like fan, lamp etc.

The rating of the inverter should not exceed 60% capacity of the inverter key. (for a 100w inverter, total load should not be more than 60W).

- 2 Select the right place to install the inverter, where good ventilation is available.

The place for installation for inverter should be nearer to the D.P switch and the energy meter position.

- 3 Select the correct place to install battery, which is nearer to the inverter and to the ventilation.
- 4 Install the inverter and battery close to each other.

Do not provide the battery away from inverter. If should be closed to the inverter because it helps in reducing the current loss due to resistance of wire.

- 5 Make wiring connection to the inverter with 1.5 mm² wire.
- 6 Connect the three pin output socket from the mains supply (Fig 1)
- 7 Connect the positive terminal of the battery (i.e red wire) to the place provided for the positive terminal on the Inverter.
- 8 Connect the negative terminal of the battery (i.e black wire) to the place provided for the negative terminal of the inverter.

When connecting battery terminals to the inverter use special auto wires, do not use common 3/20 (or)7/20 wires and ensure that the battery is fully charged.

- 9 Put grease (or) vaseline on the battery terminals for reducing the terminal corrosion.
- 10 Complete the connection Take the output from the inverter output socket and use it to power the load.

To connect the inverter output to the load use only 1/18 wire, and do not use 3/20 or 7/20 wires.

Fig 1

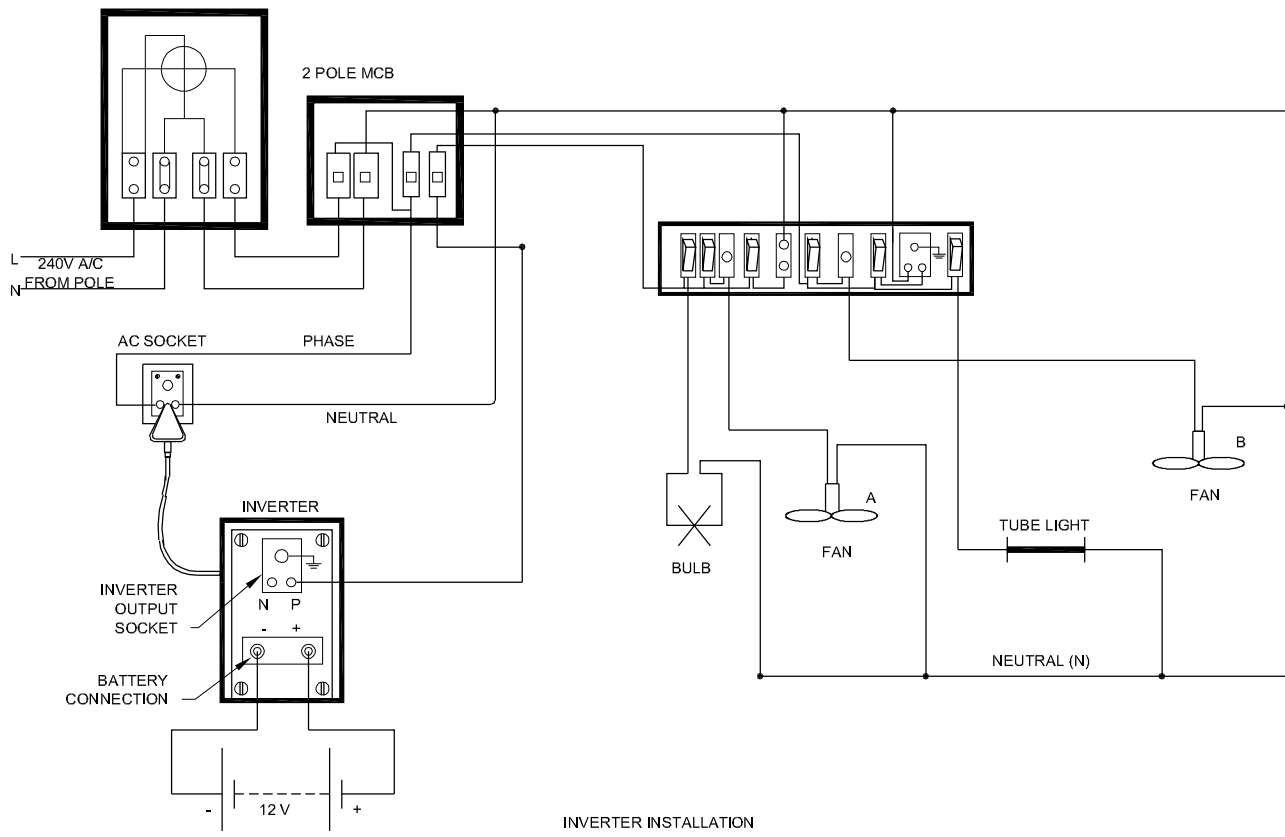

INVERTER INSTALLATION

ELN44188H1

Fig 2

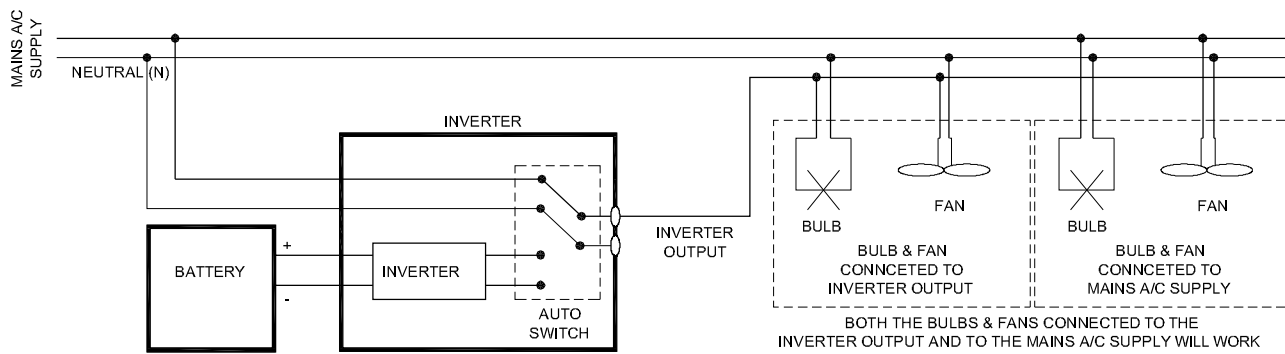

(a)

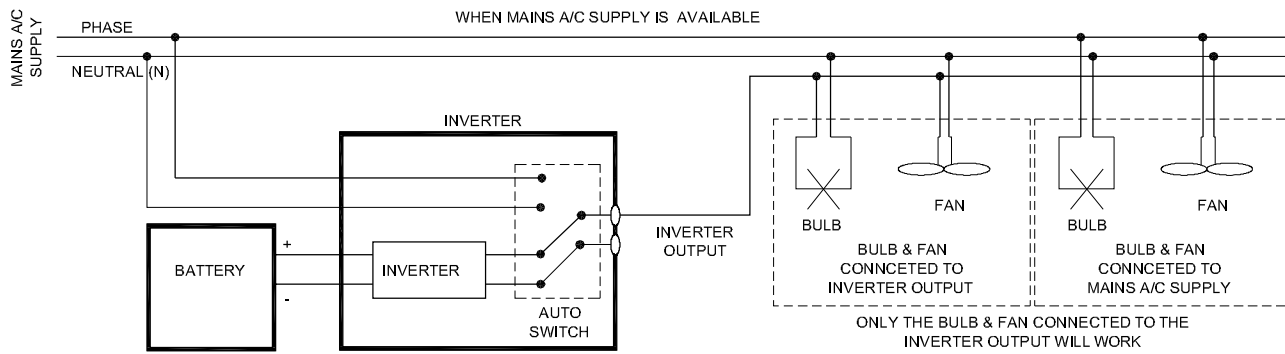

(b)

WHEN MAINS A/C SUPPLY IS NOT AVAILABLE

ELN44188H2

- 11 Connect the ON/OFF switch on the wall panel from the phase output pin of inverter output socket (Fig 1)
- 12 Connect one common Neutral line of both inverter output and mains AC supply.
- 13 Connect only one wire for the phase line from the inverter output socket to the switches.
- 14 Give connection to one bulb, one fan (A) and 2 pin socket only to the inverter output as in Fig 1.
- 15 Connect the other devices in the room i.e the tube light, fan (B) and 3 pin socket directly to the mains AC line.

Low wattage load only to be connected on the two pin socket during the power 'OFF' time. Heavy load should not be connected to this socket., such as heater, geyser, motors in HP etc.

- 16 Show the connection and get it approved by your instructor.
- 17 Check the operation of inverter during power 'OFF' and then power returns.

If the main supply is 'ON' the load connected to the inverter will get the main AC supply and the other devices which are directly connected to the mains AC supply will also work on the main supply. (Fig 2a)

During power shut down, the devices which are directly connected to the mains AC will stop functioning and the devices connected to the inverter will keep on working on the inverter output . when the mains AC supply returns the inverter will again connect the load to its output. (Fig 2b)

Draw layout of thermal power plant and identify function of different layout element

Objectives : At the end of this exercise you shall be able to

- visit the thermal power plant and identify the various stages in the plant
- interpret the function of each stages of thermal power plant
- prepare and draw the schematic diagram of thermal power plant.

Requirements			
Materials			
• Drawing sheet	- 1 No.	• Eraser	- 1 No.
• Pencil (HB)	- 1 No.	• Scale -300mm	- 1 No.

PROCEDURE

Instructor may take the trainees to a nearest thermal power plant to visit the various stages of the power station and explain the functions of each stage.

Before entering the power station the instructor should explain to the trainees all the safety regulations pertaining to the power plant.

- 1 Visit the stages of a thermal power plant i.e.
 - a. Coal and ash handling arrangement
 - b. Steam generating plant
 - c. Steam turbine
 - d. Alternator
 - e. Feed water supply
 - f. Cooling arrangement
- 2 Identify the following constituents of a steam generating plant and write down their functions in Table 1.

Table 1

Constituents	Type	Function
a Boiler		
b Super heater		
c Economizer		
d Air pre-heater		
e Turbine		
f Condenser		
g Cooling tower		
h Water treatment chamber		

- 3 Note down the details of the steam turbine and enter it in the diary.

- 4 Trace the various parts of alternator and note down the name plate details in Table 2.

Table 2

No.of phase _____	Single / three
Capacity _____	KVA / MVA
Speed _____	RPM
Output voltage _____	Volt
Current _____	Amp.
Frequency _____	Hz
Excitation current _____	Amp.
Sl.No _____	
Year of Manufacturing _____	
Model No _____	

- 5 Draw the schematic diagram of thermal power station you visited in your record and get checked by your instructor.

Fig 1 is the model schematic diagram of a thermal plant given for general guidance to trainees. The trainees have to prepare and draw the schematic diagram of the plant they visited.

- 6 Note down the main stepup transformer specification and the type of cooling arrangements.

7 Note down the voltage ranges transmitting from the power station.

Note down the boiler temperature range and method of temperature controlling and types of thermo couples used in boiler.

Fig 1

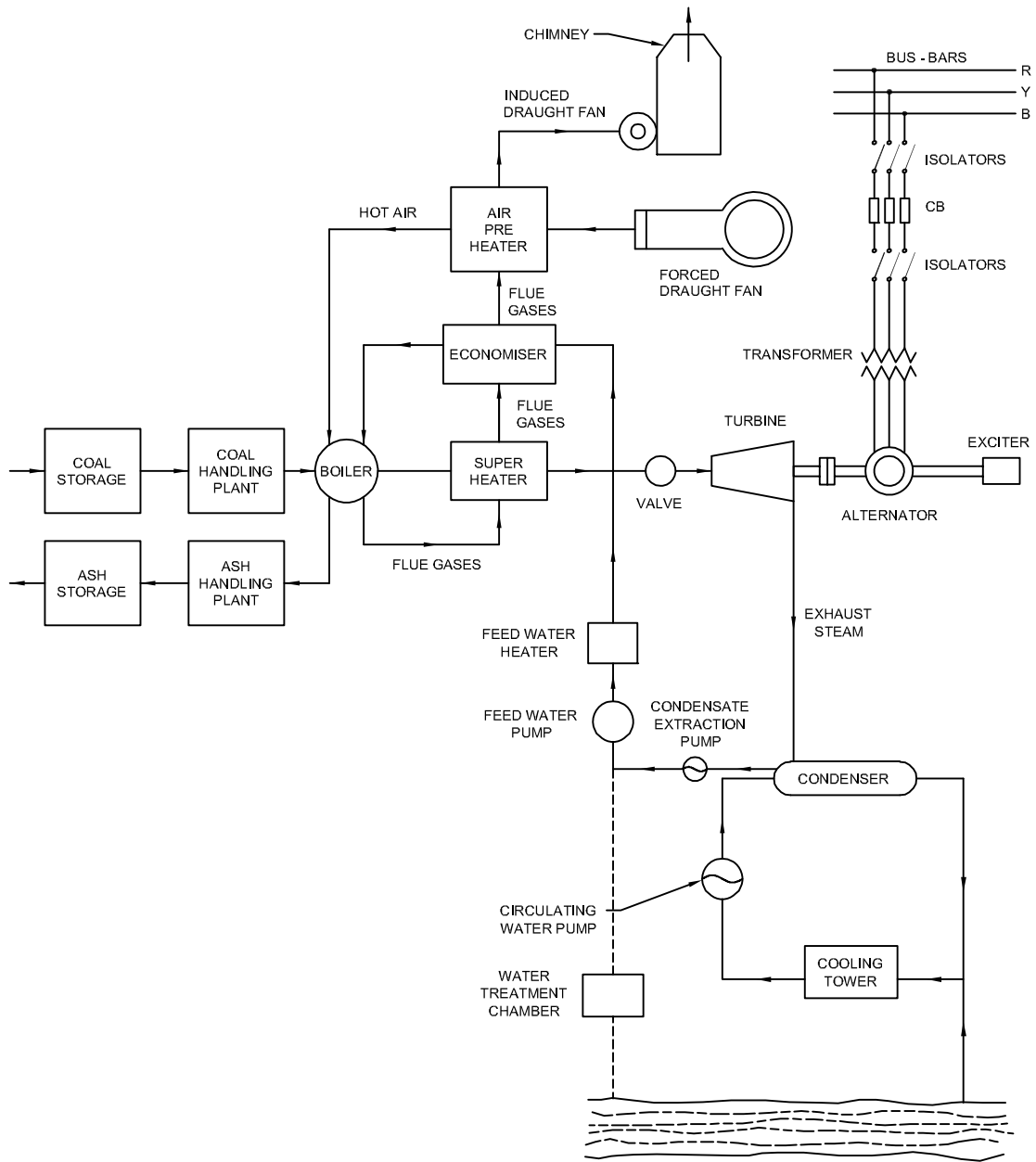

SCHMATIC ARRANGEMENT OF STEAM POWER STATION

ELN45185H1

Draw layout of hydel power plant and identify functions of different layout elements

Objectives : At the end of this exercise you shall be able to

- visit the various stages of hydro-electric plant
- interpret the functions of each hydro-electric plant
- prepare and draw the schematic diagram of hydro plant.

Requirements			
Materials			
• Drawing sheet	- 1 No.	• Eraser	- 1 No.
• Pencil	- 1 No.	• Scale -300mm	- 1 No.

PROCEDURE

Instructor may take the trainees to a nearest hydro-electric power station to visit the various stages of the power station and explain the functions of each stage.

Before entering the power station the instructor should explain to the trainees all the safety regulations pertaining to the power plant.

- 1 Visit the stages of a hydro-electric power plant i.e.(1) Hydraulic structures (2) Water turbines (3) Electrical equipments.
- 2 Identify the following stages of a hydro-electric plant and write down their functions in Table 1.

Table 1

Constituents	Type	Function
a Dam		
b Spill ways		
c Head works		
d Surge tank		
e Pen stocks		
f Tail race		
g Draft tube		
h Turbine		

- 3 Note down the speed of the water turbine and other details and enter it in the diary.
- 4 Trace the various parts of alternator and note down the name plate details in Table 2.

Table 2

No.of phase _____	Single / three
Capacity _____	KVA / MVA
Speed _____	RPM
Output voltage _____	Volt
Current _____	Amp.
Frequency _____	Hz
Excitation current _____	Amp.
Sl.No _____	
Year of Manufacturing _____	
Model No _____	

- 5 Draw the schematic arrangement of a hydro-electric power station in your record and get checked by your instructor.
- 6 Note down the main step-up transformer specifications and the type of cooling arrangements.
- 7 Ensure that the cooling arrangement of power transformer, is water cooling or any other types.
- 8 Note the transmitting voltage range and the no. of transmission lines.

- 9 Note down the total installed capacity of the power station and maximum number of turbains working together at peak load hours.
- 10 Show your observation to your instructor.

Fig 1 is the model schematic diagram of hydro electric plant given for general guidance of trainees. The trainees have to prepare and draw the schematic diagram of the plant they visited.

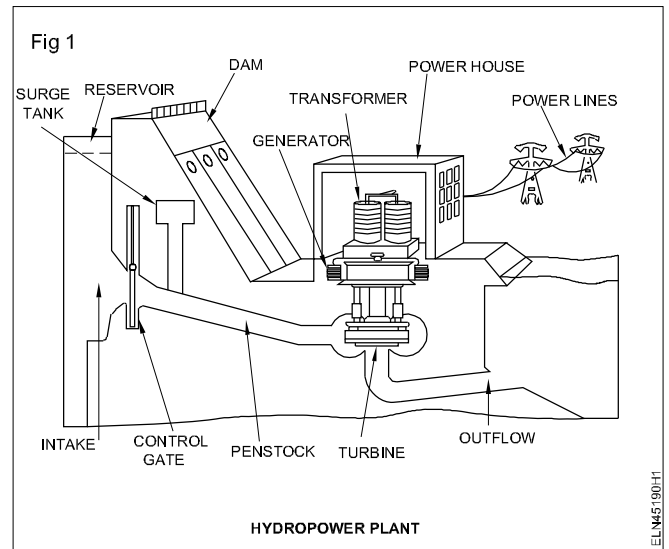

Visit to transmission/distribution substation

Objectives: At the end of this exercise you shall be able to

- visit and trace the transmission and distribution line of substation
- identify the equipments in sequential stages of distribution substation
- prepare the layout and draw the single line diagram of the transmission and distribution substation
- visit and trace the transmission and distribution line of major substation.

Requirements			
Tools/Equipment /Material			
• Drawing sheet	- 1 No.	• Eraser	- 1 No.
• Pencil (HB)	- 1 No.	• Scale-300mm	- 1 No.

PROCEDURE

The instructor may take the trainees to the nearest transmission /distribution main substation, and explain the name of the equipments, their specification and function also instruct the trainees to follow the safety regulation while visiting the substation.

- 1 Visit the transmission and distribution main substation.
- 2 Identify the sequential stages of transmission/ distribution substations.
- 3 Trace and identify the various equipments like transformers, feeders, circuit breakers, Isolator, CT & PT etc, from the generator to the consumer points in sequence of transmission and distribution substation.
- 4 Note down the earthing system. The major substation provided with system earthing. Note the different values of earth resistance displayed in the earth pit. Note down which equipment/installation requires the least earth resistance value and irregular value. Identify the hollow conductors used for connection between feeders.
- 5 Note down their details in Table 1 (Name, Specification and functions)

Table 1

Sl.No	Name of the equipments	Specification	Function
1			
2			
3			
4			
5			
6			
7			
8			

- 6 Locate the places of equipments and draw the single line diagram of transmission and distribution substation, which you have visited.

It may be like the diagrams (Fig 1, 2, 3 and 4) given for your guidance. Refer related theory of this exercise also.

- 7 Get it checked with your instructor.

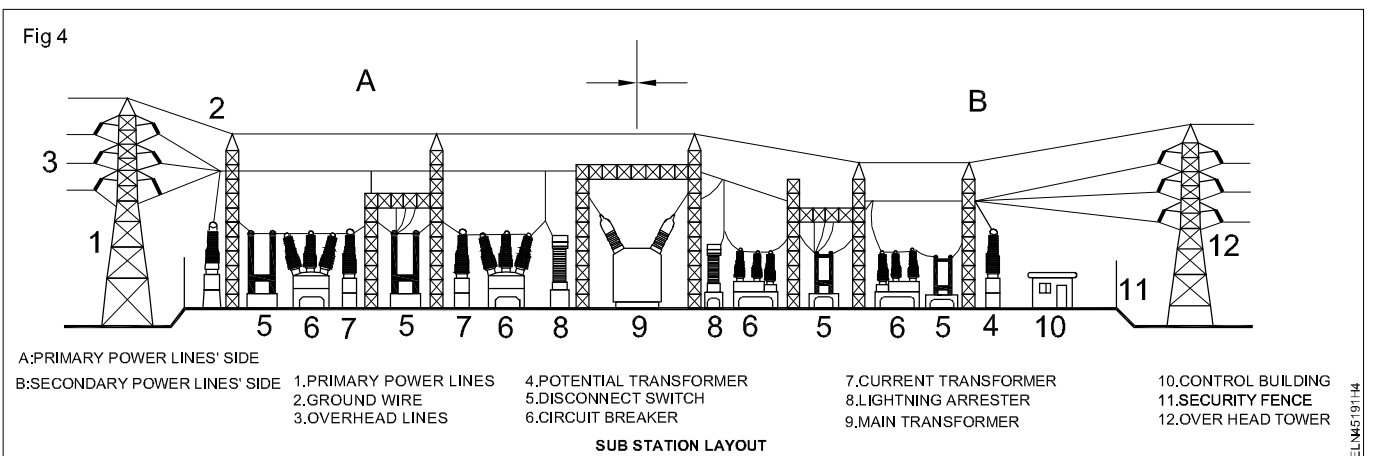
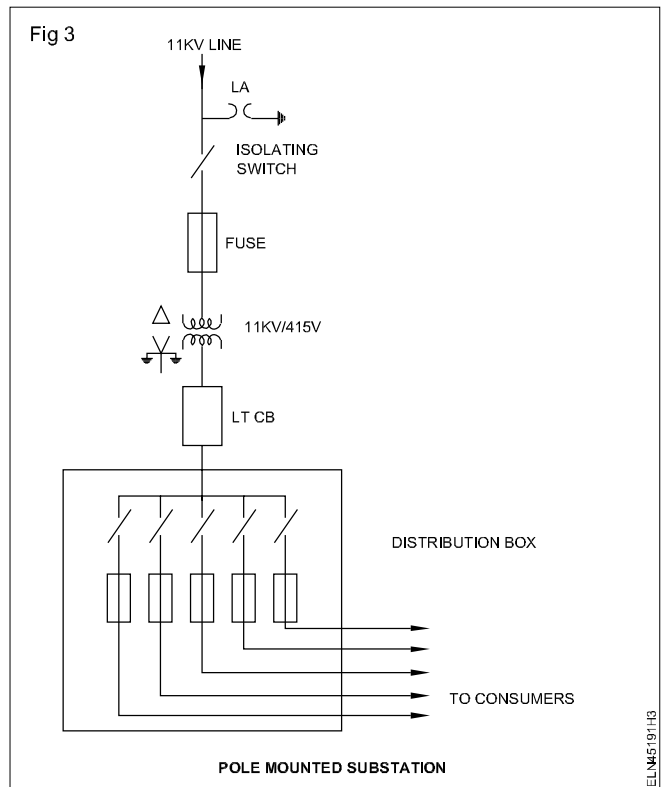
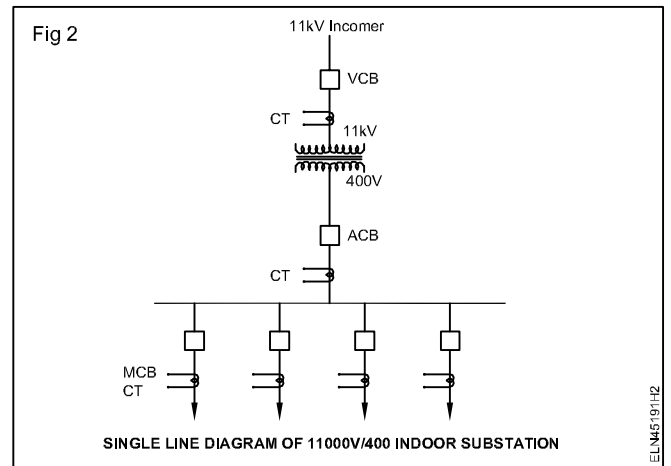
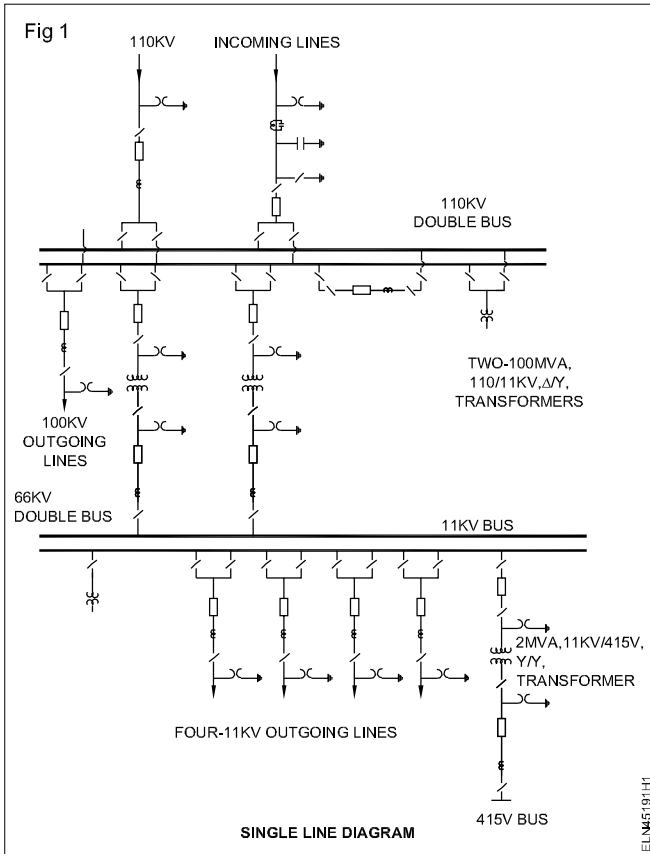

Draw actual circuit diagram of substation visited and indicate various components

Objectives: At the end of this exercise you shall be able to

- visit of substation and note down the various components
- draw the actual circuit diagram of substation with components.

Requirements

Materials

- | | | | |
|-----------------|---------|----------------|---------|
| • Drawing sheet | - 1 No. | • Eraser | - 1 No. |
| • Pencil HB | - 1 No. | • Scale -300mm | - 1 No. |

PROCEDURE

1 Visit the substation which is nearer to your institute with your instructor and note the various components installed as below.

- Incoming protection devices and their installations.
- Transformer specification - voltage rating capacity cooling method, earthing, HT and LT terminal connections.
- Installation of CTs and PTs and their connections.
- Installation of over voltage, under voltage, over current, earth fault relays and their protections - earthing - etc.
- Position of isolators, earth switches, feeders cable terminations and lights arrestors etc.
- Number of earth pits and their resistance values- periodical maintenance and testing procedure.

- The load distribution method adopted in substation to customers.
 - Methods followed in substation to meet maximum demand and monitoring.
 - Substation maintenance chart and methods to carryout maintenance without effecting power shut down totally.
 - Any other points noticed or learned in the substation.
- 2 Draw the circuit diagram of substation, which actually you visited and draw the layout diagram of substation with various components.

Refer the drawing illustrated in previous Exercise 4.5.191 (Fig 4) for your reference.

3 Get it checked with your instructor.

Prepare layout plan and identify different elements of solar power system

Objectives : At the end of this exercise you shall be able to

- visit and interpret the details of solar power plant
- trace and identify the components used in solar plant and write their functions
- prepare and draw the schematic diagram of solar power plant.

Requirements			
Materials			
• Drawing sheet	- 1 No.	• Eraser	- 1 No.
• Pencil HB	- 1 No.	• Scale -300mm	- 1 No.

PROCEDURE

Instructor may take the trainees to the nearest solar power plant to visit the various stages of power station and explain the function of each stage.

Before entering the power station the instructor should explain to the trainees all the safety regulations pertaining to the power plant.

- 1 Visit the solar plant and note the details of the plant.
 - i Capacity of the plant _____ KW / MW
 - ii Output voltage _____ KV
 - iii Permitted Maximum Load Circuit _____ Amp.
- 2 Trace and locate the components used in that solar plant.
- 3 Note down their functions as in Table 1
- 5 Note specification of solar panels - make, voltage ratings etc.
- 6 Note tracking systems method provided for maximum output.
- 7 Note protection of cells from natural calamities.
- 8 Note installed cells whether in ground level or elevated.
- 9 Draw the schematic diagram of solar power plant as per the guidance. (Fig 1)
- 10 Get your work checked by instructor.

Table 1

Sl.No.	Name of the components	Functions/ specifications
1	Total solar panel area	
2	Method of mounting panels	
3	Controller circuits	
4	Battery system installed	
5	DC/AC Inverter Capacity & Voltage ratings	
6	Distribution panel to grid connections	

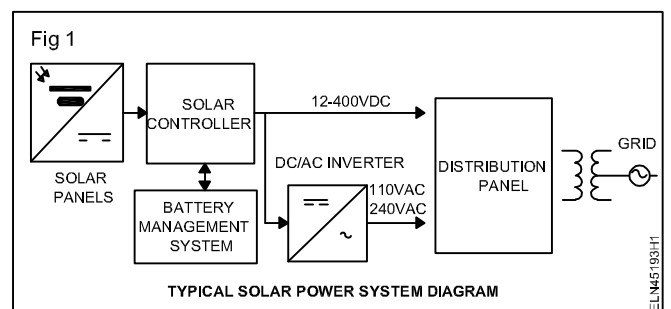

Fig 1 is the model schematic diagram of solar power plant given for the general guidance of trainees. The trainees have to prepare and draw the schematic diagram of the solar power plant they visited.

- 4 Note down the daily average power output of the plant for distribution.

Prepare layout plan and identify different elements of wind power system

Objectives : At the end of this exercise you shall be able to

- visit and identify the various components used in wind power generation plant
- prepare and draw the schematic diagram of wind power plant.

Requirements			
Materials			
• Drawing sheet	- 1 No.	• Eraser	- 1 No.
• Pencil HB	- 1 No.	• Scale - 300 mm	- 1 No.

PROCEDURE

Instructor may take the trainees to the nearest wind power plant to visit the various stages of power station and explain the function of each stage.

Before entering the power station the instructor should explain to the trainees all the safety regulations pertaining to the power plant.

- 1 Visit the wind mill power plant, and note the details of the plant.
 - i Capacity of the plant _____ KW / MW
 - ii Output voltage _____ KV
 - iii Maximum load Current _____ Amp.
- 2 Trace and identify the equipments/parts used in this wind mill power plant.
- 3 Write the names of the equipments and their functions in Table 1.
- 4 Note down the daily average power output of the plant.
- 5 Note down the minimum rpm of turbine to maintain the rated voltage.
- 6 Note down the chopper/circuit characteristics and its importance in turbine controller.
- 7 Note down the protection provided from natural calamities.
- 8 Prepare and draw the schematic diagram of wind power station in your diary and get checked by the instructor.

Table 1

Sl.No.	Name of the equipments/parts	Specification Functions
1	No. of wind blades	_____
2	Gear box	_____
3	Generator	_____
4	Exciter	_____
5	Turbine controller	_____
6	Rectifier Unit (RU)	_____
7	Line Converter Unit (LCU)	_____
8	High voltage transformer	_____
9	Internal Supply Unit (ISU)	_____
10	Chopper	_____
11	Wind turbine	_____
12	Grid	_____

Fig 1 is the model schematic diagram of wind power station given for the general guidance of trainees. The trainees have to prepare and draw the schematic diagram of the plant they visited.

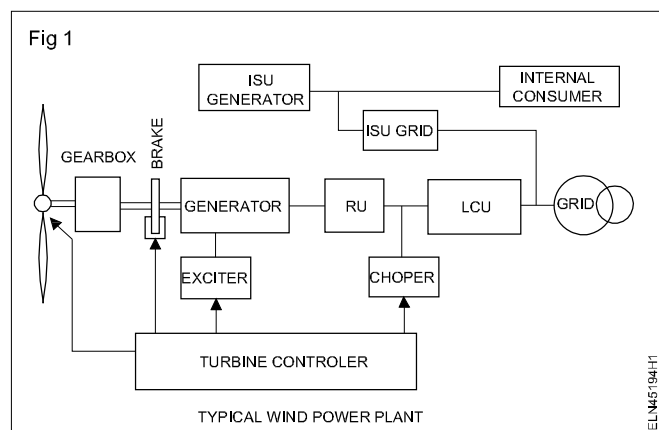

Assemble and connect solar panel for illumination

Objectives: At the end of this exercise you shall be able to

- calculate the total no. of cells required to make series parallel combination for one panel
- fix the 4 Nos of LED lamp 12V/3W at required position in the lamp
- Wire the circuit from panel to light in the lab
- fix the panel board with control and protection devices to illuminate the lab
- assemble and install solar panel at mid clamp and roof top.

Requirements			
Tools/Equipments			
• Trainees kit	- 1 No.	• LED lamp with shad and reflector 12V/3W	- 4 Nos.
• Multimeter	- 1 No.	• Fixing screws, wiring accessories	- as reqd.
• Power drilling/hammering machine with suitable drill bits	- 1 Set.	• Base pipe	- as reqd.
• Solar panel	- 1 No.	• Contact pipe	- as reqd.
Material		• Supporting pipe	- as reqd.
• Solar cells 0.45 V/57mt. 125mW/cm ²	- 540 cells	• Rail splice	- as reqd.
• Connecting wires 1 sq.mm PVC cable	- as reqd.	• Rail	- as reqd.
• Gang box with one switch (F/type one way) 250V/5A	- 4 Nos.	• Rail contract AC	- as reqd.
• Panel frame suitable to fix the wired solar cells	- 4 Nos.	• End clamp	- as reqd.
		• Mid clamp	- as reqd.
		• M8x25mm screws	- as reqd.
		• Bolt and nuts	- as reqd.

PROCEDURE

TASK 1 : Calculate the number of cells required to illuminate one panel

(Assume the lamp voltage is 12V and power 3W)

1 Determine the number of solar cells in series group.

$$\text{No. of cells in series group} = \frac{\text{Total required voltage}}{\text{Volt/cell}}$$

$$1 \text{ cell} = 0.45 \text{ V and } 57\text{mA}$$

$$= \frac{12\text{V}}{0.45} = 27 \text{ cells.}$$

27 x 0.45 = 12.15V considering line losses voltage of 0.15 V taken as extra (0.15V taken for line lines)

No. of series group required for the correct of 250mA

$$= \frac{\text{Current required for one lamp}}{\text{Current in one series group}}$$

$$(\text{LED lamp requires } 250 \text{ mA}) = \frac{250\text{mA}}{57\text{mA}}$$

$$= 4.38 = 5 \text{ groups}$$

Considering the line losses few cells one connector for extra current.

TASK 2 : Assemble of solar panel and its installation

- 1 Collect solar cells and make the series connection. (27 cells in series) on the panel board.
- 2 Prepare five nos of series connection and wire them for parallel as shown in Fig 1.
- 3 Make four similar solar panels in total.
- 4 Locate the suitable places and fix it on roof top where sunlights are falling directly.

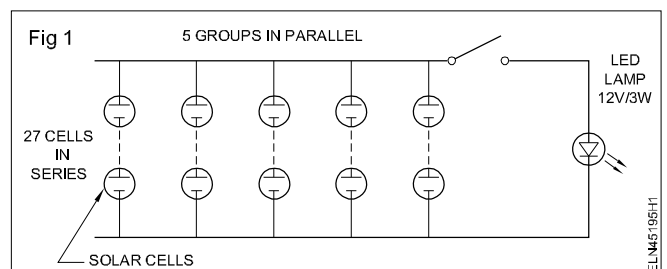

Locate the places of fixing panels should not be under shadows of trees and buildings etc.

TASK 3 : Fix lamps and gang box

- 1 Locate the lamp position and switch position as short as possible from solar panel for all the four panels.
- 2 Wire the panel to gang box and the lamp neatly.

Wiring can be done in PVC conduit or PVC casing and capping to give aesthetic look

- 3 Fix the lamp assembly and complete the wiring with switch control.

- 4 Test the wiring for any short (or) open circuit fault.
- 5 Connect the wire to the panel terminals and measure the voltage at lamp terminal.
- 6 Connect the lamp and operate the switch for illumination.
- 7 Report to your instructor for his approval.

TASK 3 : Assemble and install solar panel at mid clamp roof top

- 1 Select the roof without shading for the solar panel installation.
- 2 Check that sure the direction of installation of the solar panels receives more sun rays to mount the solar panel.

Select an area of roof to install the solar panels that gets the sun light rays as along as possible all days.

The solar panels can either be mounted flush on the roof or stand, or mounted at an angle to maximize the position of accessibility to the sun's direct rays.

- 3 Collect contact pipe with M8 x 25 contact base pipe. (Fig 1)

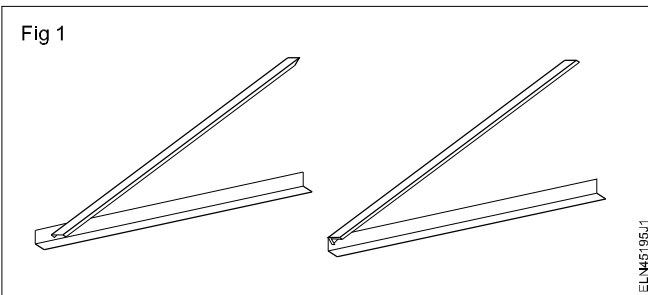

- 4 Fix the contact support pipe and contact pipe with M8 x 25 screw. (Fig 2 & 3)

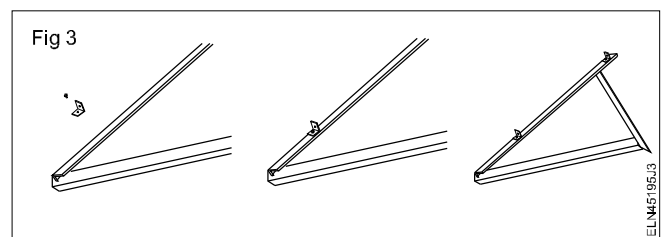
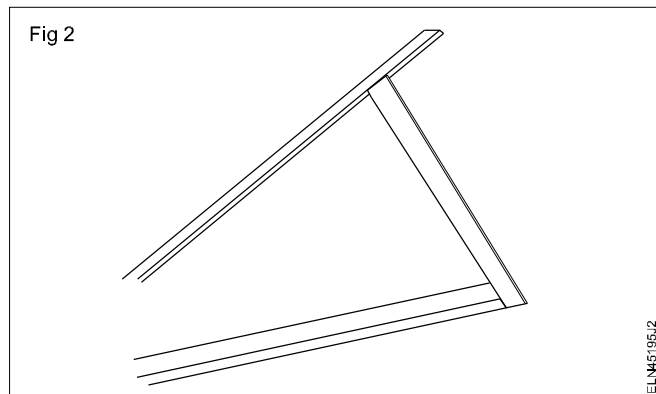

- 5 Take 2 fixed tile rack and position them with rail as in Fig 4.

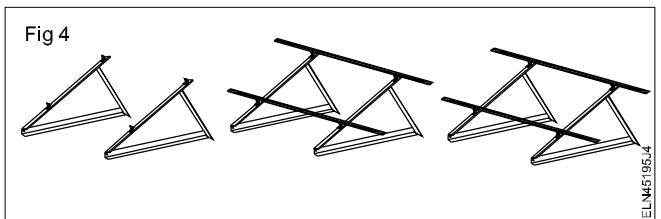

- 6 Put one panel on the rack, use 2 end clamps to hold and fix it (Fig 5). (Attention end of rail distance must <25mm to 30mm).

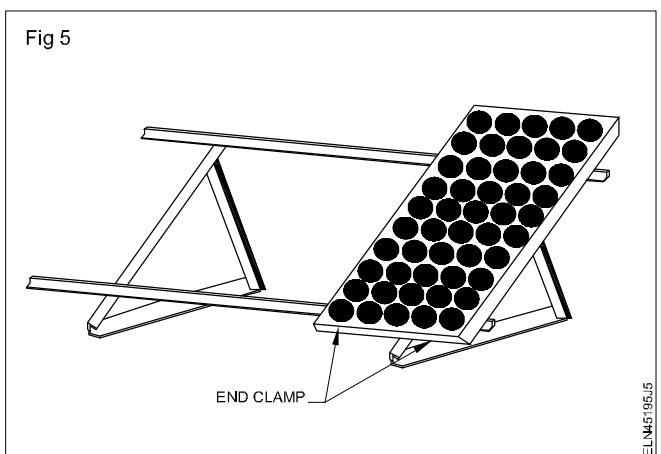

- 7 Install the modules an mid clamp and end clamp.
- 8 Install panel by fixing mid clamp between panels. (Fig 6)
- 9 Select the best/perfect angle for solar panels with the help of manual to produce the maximum power.
- 10 Drill the hole on the roof with the help of drilling machine.
- 11 Fix the frame with the help of screws and place the panel on frame. (Fig 7)

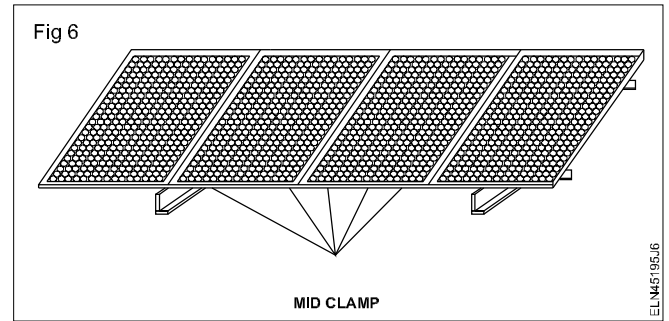

- 12 Get the work checked by the instructor.



Practice installation of insulators used in HT/LT lines for a given voltage range

Objectives: At the end of this exercise you shall be able to

- identify the type of HT/LT line insulators
- install the shackle type insulator on HT over head line
- install the pin type insulator on LT over head line.

Requirements	
<p>Tools/Instruments</p> <ul style="list-style-type: none"> • Insulated combination plier 200 mm - 1 No. • DE spanner set 6mm to 25 mm - 1 Set. • Adjustable spanner 6mm to 25 mm - 1 Set. • Safety belt - 1 No. • Wooden or nylon mallet 1/2 kg - 1 No. • Ladder 6m long • Jute rope of 25 mm dia and 15 m length - 1 No. • Wire stretcher 25 mm - 1 No. • Megger 500 V - 1 No. 	<p>Materials</p> <ul style="list-style-type: none"> • Shackle insulator, porcelain 1kV - 4 Nos. • Pin insulator, porcelain 1kV - 2 Nos. • Suspension insulator - 1 No. • Strain insulator - 1 No. • Ring insulator - 1 No. • Stay/egg insulator - 1 No. • Cotton waste - as reqd. • Binding wire 14 SWG aluminium - as reqd. • Scrap piece of ACSR conductor of length 1m (for bow) - 3 pieces • Sandpaper or emery sheet - as reqd. • Flat aluminium tape - as reqd. • Protective grease suitable to apply over the ACSR line conductor - as reqd. • Line accessories - as reqd.

PROCEDURE

TASK 1 : Identify the LT and HT types of insulators

1 Identify the LT and HT type line insulators from Figures 1 to 6.

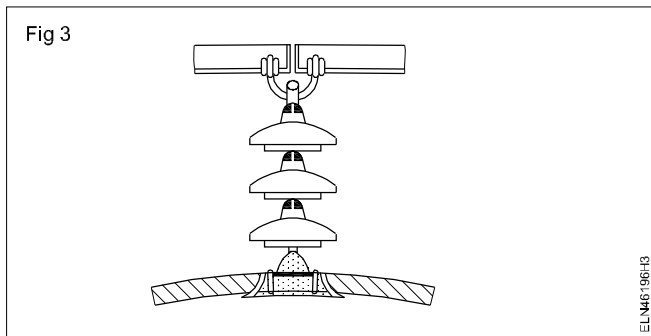
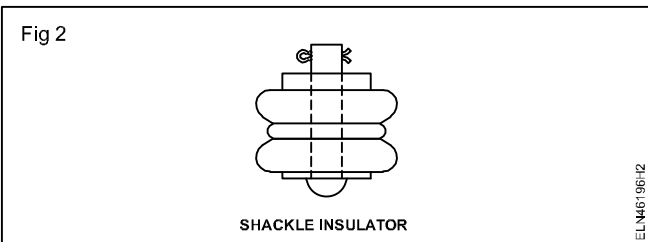
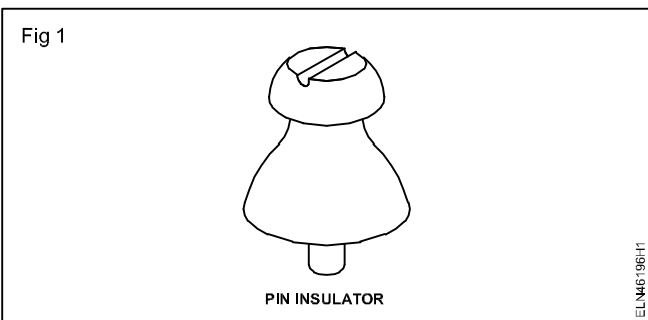

2 Write their names with voltage range and purpose in Table 1.

3 Get it checked with your instructor.

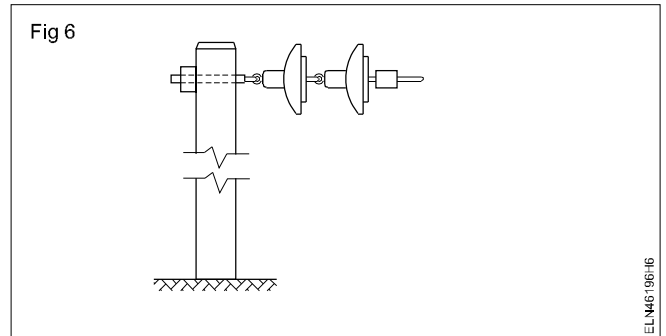
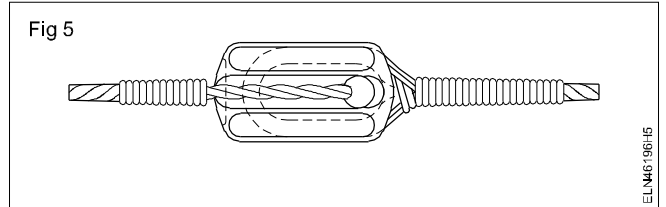
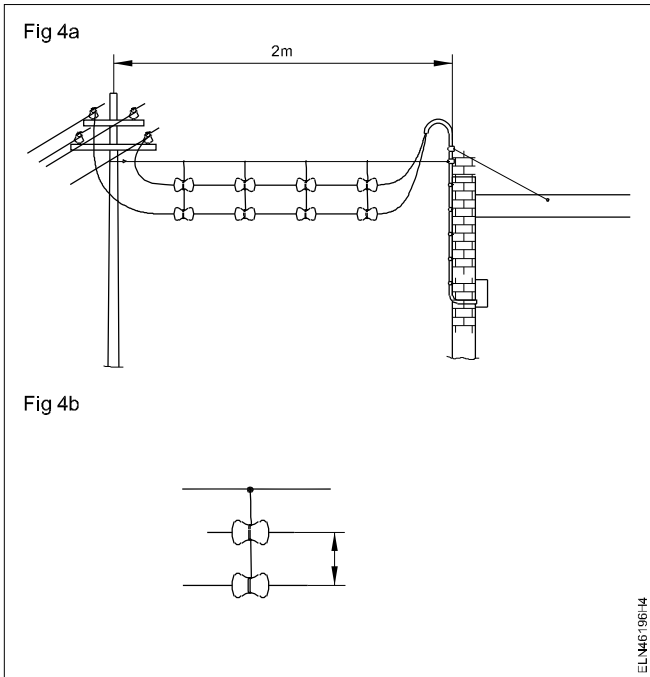

Table 1

Sl.No	Name of the Insulator	Voltage range	Purpose of insulator
1			
2			
3			
4			
5			
6			

TASK 2 : Install the shackle insulator in HT

Take shutdown if the nearest lines are energised. Use a safety belt while working on a pole.

Before starting the work check the ladder, safety belt and all the connected accessories.

- 1 Fasten the safety belt, lay the ladder on the pole.
- 2 Release the conductor from the reel, measure the actual span plus sag and binding. Keep two lengths of conductor. (Length of span + 1ft. Sag)
- 3 Check the shackle insulator for its damage and select a good one. (Clean and carbonize etc.)
- 4 Check the assembly of the shackle insulator for its proper fitting.
- 5 Ask the helper to hold the ladder, climb up the ladder with the guide rope and spanner set.

While working on the ladder, the ladder should be held by a helper to avoid slipping.

- 6 Position yourself conveniently on the cross-arm, tie the safety belt end to the cross-arm. Send one end of guide rope to the helper and ask him to tie to the shackle assembly and lift it to the top.
- 7 Fix the shackle insulator to the cross-arm by 'C' clamps. (Fig 1)

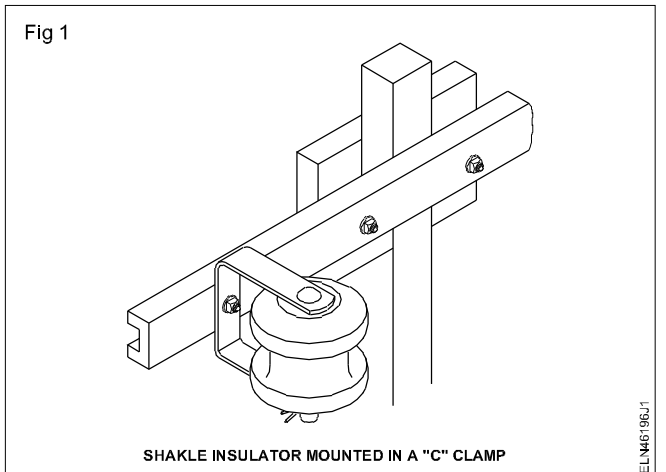

- 8 Get the draw pulley from the ground and secure it on the cross-arm. Interlace the rope through the pulley and send the other end to the helper.
- 9 Ask the helper to properly tie the O.H. conductor to the rope and lift the conductor to the cross-arm position.

While lifting the conductor both the end conductors should be lifted at a time first, and then middle conductors to avoid the fitting of the cross-arm.

While tying, the conductor to the rope the helper should leave at least 1 metre length of conductor free at the end from binding.

- 10 Twist the end portion of the conductor over the main line conductor. (Fig 2)

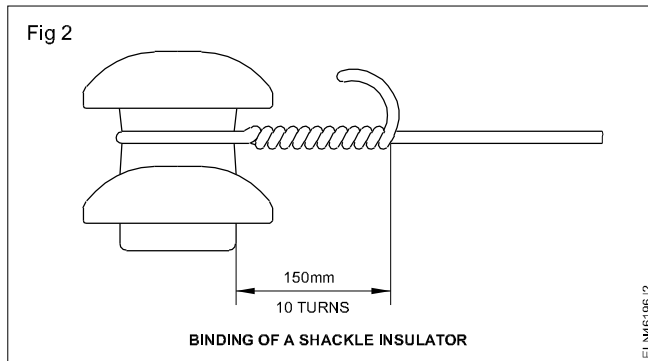

- 11 Bind the shackle insulators with the one fixed at the last cross-arm.

Ground clearance of overhead conductor should not be less than 4.572 m for low and medium voltage.

- 12 Get down from the pole after checking the binding.

TASK 3 : Install the pin type insulator in LT

- 1 Climb the next pole following the previous procedure
- 2 Lift the conductor and keep it on the pin insulator. Ask the other helper to lift and stretch the conductor with wire stretcher.
- 3 Fix the pin insulator to the cross-arm of the existing pole.

If the span is less, there is no need to use a draw pulley, pulling with the help of a rope is sufficient.

- 4 Bind the pin insulators as per procedure.

The binding wire must be of the same metal as the line wire.

Binding should be mechanically strong.

- 5 Bind the free ends of the binding conductor over the line conductor tightly in the opposite direction. (Fig 3)

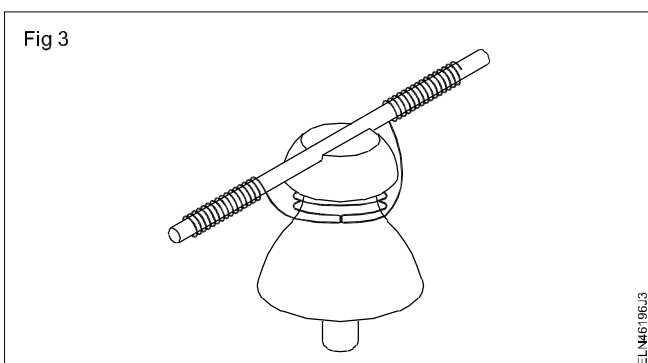

Binding should be tight without any gap.

Alternatively the conductor can be placed in the side groove for binding the conductor with the pin insulator as in Fig 4.

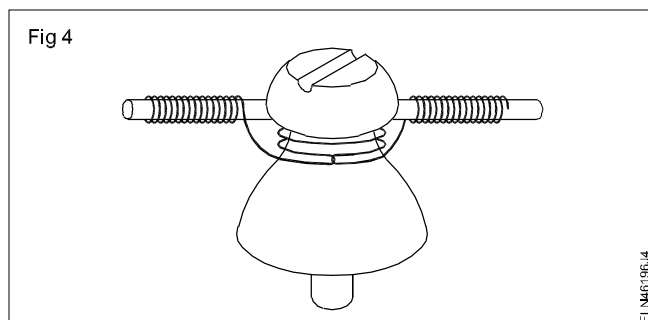

- 6 Complete the binding by giving about 15 turns on both sides.

- 7 Cut the extra binding wire and round off the raised ends.

- 8 Repeat the procedure for the other pin insulator by the side of the same cross arm.

Check the bindings before getting down. No tool and wire should be left on the cross-arm.

- 9 Test by a Megger of 500 Volt for insulation between conductors and insulation resistance between conductors and earth. Enter in Table 2.

Table 2

Test results

Sl.No.	Measurement between	Insulation value
1	Insulation resistance between conductors	Megohm
2	Insulation resistance between first conductor and earth	Megohm
3	Insulation resistance between second conductor and earth	Megohm

The distribution lines shall be charged only when the megger test is satisfactory. It must be a minimum of 1M and above for medium voltage lines.

10 Climb on the first pole and tie the jumpers for extending connections to the existing supply line to the new erected line. Carry out the same procedure for other conductor also.

Verify before touching any overhead time whether the tine is dead and all the safety measures are followed.

Draw single line diagram of transmission and distribution system

Objectives: At the end of this exercise you shall be able to

- visit and trace the transmission and distribution system
- identify the equipments in sequential stages of transmission and distribution system
- prepare the layout and draw the single line diagram of the transmission and distribution system.

Requirements			
Tools/Equipment /Material			
• Drawing sheet	- 1 No.	• Eraser	- 1 No.
• Pencil (HB)	- 1 No.	• Scale-300mm	- 1 No.

PROCEDURE

The instructor may take the trainees to the nearest transmission and distribution line system and explain the name of the equipment, their specification and function also instruct the trainees to follow the safety regulation while visiting the substation.

- 1 Visit the transmission and distribution line system and power plant.
- 2 Identify the sequential stages of transmission and distribution line system.
- 3 Trace and identify the various equipments like transformers, feeders, circuit breakers, Isolator, CT and PT etc, from the generation to the consumer points in sequence of transmission and distribution system.
- 4 Note down the earthing system. Note the different values of earth resistance displayed in the earth pit. Note down which equipment and installation requires the least earth resistance value and irregular value. Identify the hollow conductors used for connection between feeders.
- 5 Note down their details in Table 1 (Name, Specification and functions) for transmission system and Table 2 for distribution system.

Table 1

Transmission system

Sl.No	Name of the equipment	Specification	Function
1			
2			
3			
4			
5			
6			
7			
8			

- 6 Locate the places of equipments and draw the single line diagram of transmission and distribution system. Which you have visited.

It may be like the diagram shown in Fig 1, 2. Refer related theory of this exercise also.

Table 2
Distribution line system

SI.No	Name of the equipments	Specification	Function
1			
2			
3			
4			
5			
6			
7			
8			

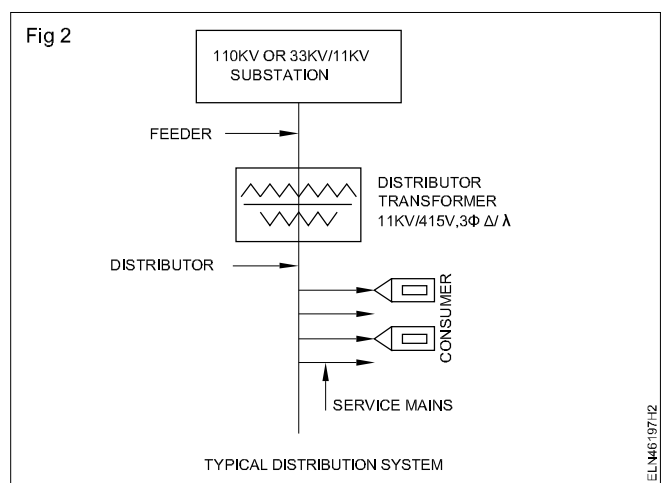
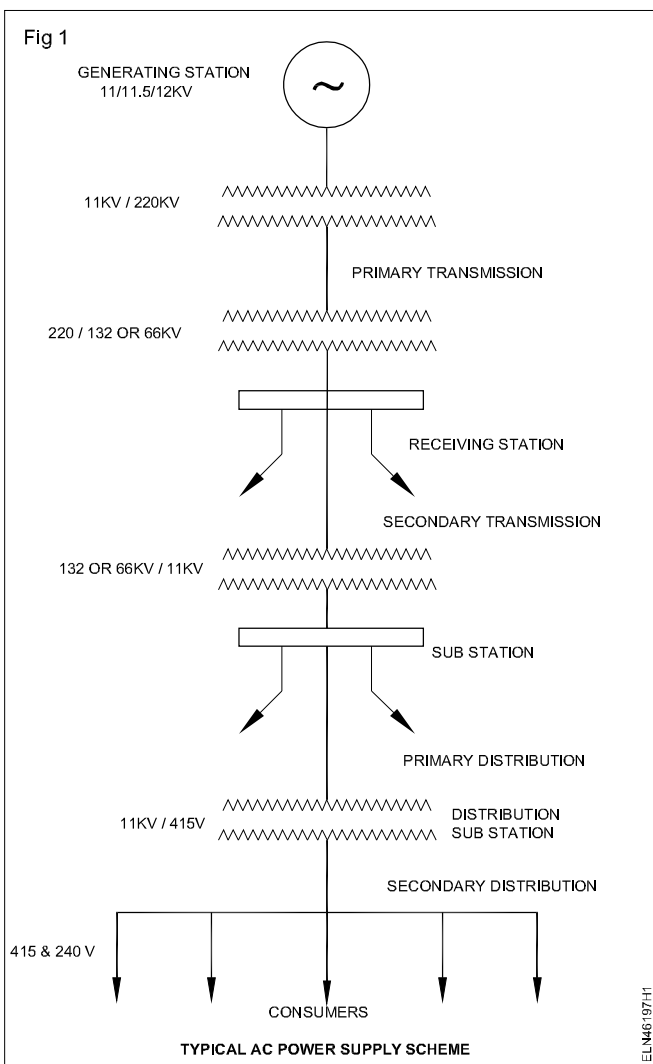

Measure current carrying capacity of conductor for given power supply

Objectives: At the end of this exercise you shall be able to

- identify and select 3 different conductors i.e. copper, aluminium and alloy
- connect the circuit and measure the breaking current of the conductor.

Requirements	
Tools/Instruments/Equipment	Material
<ul style="list-style-type: none"> • Trainees tool kit - 1 No. • Ammeter M.C. 0-10A - 1 No. • Voltmeter M.C. 0-15V - 1 No. • Rheostat 270Ω 2A - 1 No. • Lead acid battery 12V 60AH - 1 No. 	<ul style="list-style-type: none"> • Wooden board with switch 16A 250V - 1 No. • 32 SWG copper conductor, aluminium conductor and alloy conductor - 10 cm • Connecting wires 2.5 sq.mm copper - as reqd.

PROCEDURE

- 1 Select 32 SWG copper conductor, aluminium conductor and alloy conductor of 10 cm length each.
- 2 Connect it on the test board. (Fig 1)

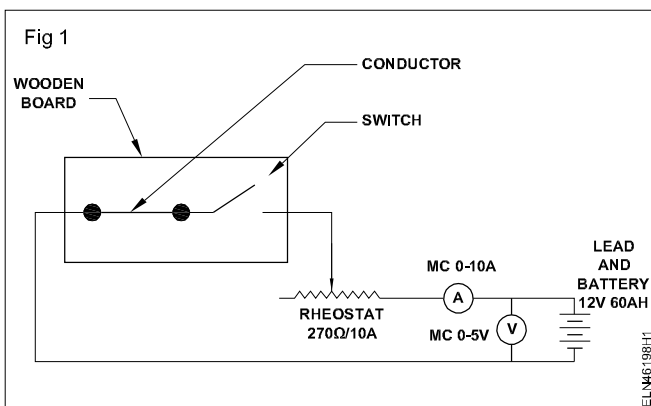

- 3 Connect rheostat, ammeter voltmeter and battery. (Fig 1)
- 4 Keep rheostat at cold end (maximum resistance position) and switch 'ON' and note the ammeter and voltmeter readings and enter in the Table 1.
- 5 Move the rheostat at middle position and note down the ammeter and voltmeter readings and enter in Table 1.

At this stage the conductor may get heated up (or) it will show the system of heating.

- 6 Adjust further more the rheostat position to hot end (reduce the resistance) slowly keeping a watch on conductor it may brake now.
- 7 Observe if the conductor is not broken and increase further position of rheostat towards hot end till the conductor breaks and note down the corresponding meter readings in Table 1.
- 8 Note down this is the maximum current carry capacity of the conductor.

If the conductor is not broken, reduce the thickness of conductor (or) change the battery.

- 9 Connect the aluminium and alloy conductor separately and repeat the steps to find the maximum current capacity of the 2 to 9 conductors.
- 10 Tabulate all the readings and show to your instructor.
- 11 a Maximum current capacity of copper conductor is _____ Amp
- b Maximum current capacity of aluminium conductor is _____ Amp
- c Maximum current capacity of alloy conductor is _____ Amp

Table 1

Sl.No.	Rheostat Position			Conductor	Voltage	Current	Remarks
	Cold end	Mid end	Hot end				
1		X	X	Copper			
2	X		X				
3	X	X					
4		X	X	Aluminium			
5	X		X				
6	X	X					
7		X	X	Alloy			
8	X		X				
9	X	X					

'X' denotes the inactive positions of the rheostat and blank space denotes active positions in the above Table 1.

Fasten, jumper in pin, shackle and suspension type insulators

- Objectives:** At the end of this exercise you shall be able to
- select the pin type, shackle type and suspension type insulators
 - fasten jumper in cross-arm of pole with pin insulator
 - fasten the jumper in shackle type insulator
 - fasten the jumper in suspension type insulator.

Requirements	
<p>Tools/Equipment /Material</p> <ul style="list-style-type: none"> • Insulated combination plier 200mm - 1 No. • DE spanner set 6 to 25mm - 1 Set • Adjustable spanner 25mm - 1 No. • Wooden or nylon mallet 1/2kg - 1 No. • Ladder 6m long - 1 No. • Wire stripper 150mm - 1 No. 	<p>Material</p> <ul style="list-style-type: none"> • Suspension type insulator - 2 Nos. • Shackle type insulator - 2 Nos. • Pin type insulator - 2 Nos. • Flat aluminium tape - as reqd. • Binding wire 14 SWG aluminium - 5m • ACSR conductor - as reqd. • Safety belt - 1 No. • Clamp - as reqd. • Nut and bolt - as reqd.

PROCEDURE

TASK 1 : Fasten the jumper in pin insulator

- 1 Keep the ladder on the pole and ask the helper to hold the ladder. climb up the ladder with the guide rope and spanner set.
- 2 Fix the pin type insulator to the cross-arm of the existing pole.
- 3 Tape the neck of the pin insulator with flat aluminium tape.
- 4 Lift the Aluminium Contactor Steel Reinforced (ACSR) conductor and keep it in between pole and the pin insulator.
- 5 Lay the ACSR wire on the slot of the pin insulator and ask the other helper to stretch the conductor with a wire stripper.
- 6 Take the binding wire of about 2 metres length, leaving equal length on both sides. Bind two turns on the insulation (Fig 1a) around the neck of the pin insulator.

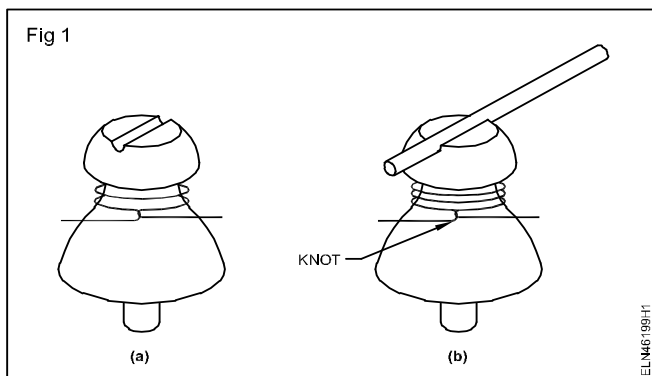

- 7 Make a knot of the binding wire with the free ends tightly. (Fig 1b)

Binding should have mechanical strength.

- 8 Bind the free ends of the binding conductor over the line conductor tightly in the opposite direction. (Fig 2)

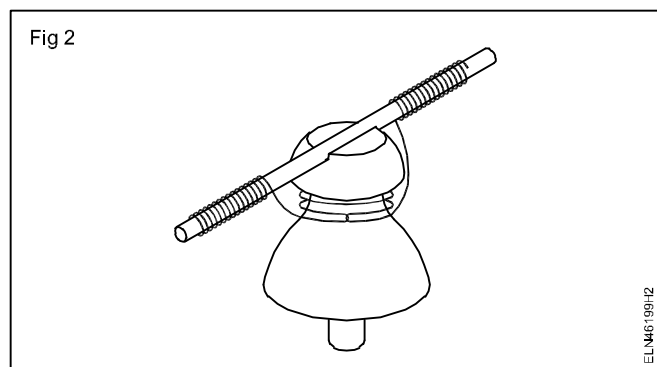

Binding should be tighten without any gap. Where deviation or bend comes the ACSR conductor bind on the neck of the pin insulator. (Fig 3)

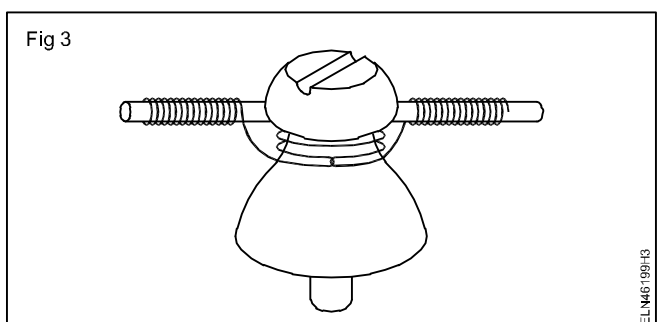

9 Complete the binding by giving about 15 turns on both sides.

10 Cut the extra binding wire and round off the raised ends.

TASK 2 : Fasten jumper in shackle insulator

- 1 Keep the ladder on the pole and ask the helper to hold the ladder. Climb up the ladder with the guide rope and spanner set.
- 2 Fix the shackle insulator to the cross-arm with 'C' clamp.
- 3 Tape the ACSR conductor with flat aluminium tape where it touches the insulator.
- 4 Ask the helper to properly tie the O.H. conductor to the rope and lift the conductor to the cross-arm position.

While tying the conductor to the rope the helper should leave atleast 1 metre length of conductor free at the end for binding.

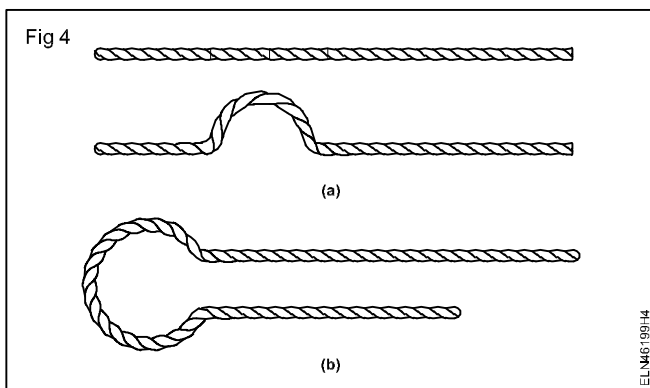

- 5 Insert the conductor around the groove of the insulator leaving half metre at the end. (Fig 4a & 4b)
- 6 Bind the ACSR conductor with 14 SWG aluminium binding wire tightly (Fig 5a) about 100 to 150 mm approximately.
- 7 Bend the end of the ACSR conductor in Fig 5(b). and complete the binding work .

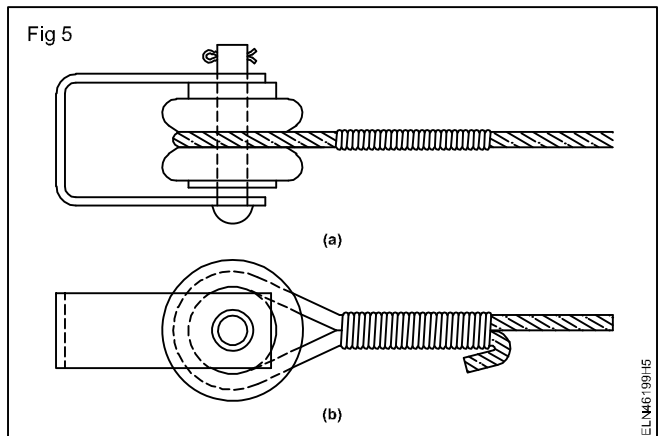

Ground clearance of overhead conductor should not be less than 4.572 M for low and medium voltage.

TASK 3 : Fasten Jumper in suspension type insulator

- 1 Keep the ladder on the pole and ask the helper to hold the ladder. Climb up the ladder with the guide rope and spanner set.
- 2 Fix the suspension insulator to the cross-arm.
- 3 Ask the helper to properly lift the conductor to the cross-arm position.
- 4 Place the conductor in between two clamps.
- 5 Tight the bolt & nut of the clamp perfectly.
- 6 Bind the ACSR conductor with 14 SWG aluminium wire tightly Fig 6 in the suspension insulator.

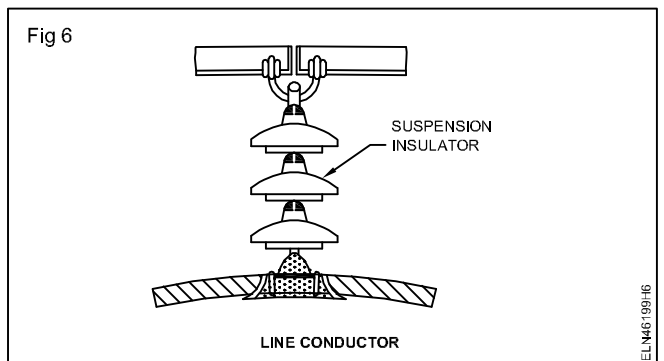

- 7 Complete the work and report to your instructor.

Erect an overhead service line pole for single phase 240V distribution system in open space

Objectives: At the end of this exercise you shall be able to

- select the place to erect the pole
- select the type of pole to be erected
- fix the cross-arm on the pole
- dig the pit and erect the pole.

Requirements

Tools/Instruments

- D.E. spanner set 6mm to 32mm - 1 Set.
- Combination pliers 200mm - 1 No.
- Heavy duty screwdriver 300mm - 1 No.
- Safety belt to work on pole - 1 No.
- Crowbar 2m long 40mm dia - 1 No.
- Spade - 1 No.
- Shovel - 1 No.
- Plumb bob with thread - 1 No.
- Cotton or jute rope 15m long - 1 No.
- Hammer ballpein 500g - 1 No.
- Safety belt - 1 No.
- Bamboo ladder - 1 No.
- Draw pulley - 1 No.
- Aligning rod - 1 No.
- Metal ram - 1 No.

Materials

- Wooden/RCC/iron/tubular pole of 6m length - 1 No.

- M.S. angle iron cross-arm 50mm x 50mm x 6mm size suitable for 240V supply line - 1 No.
- 'C' clamp M.S. size as required with nuts, bolts and washers - 2 Sets.
- Country wood plank 2m long, 30cm width 5cm thick - 1 No.
- Cement, sand, blue metal chips etc as per the size of pit - as reqd.
- Stay insulator (egg insulator) - 2 Nos.
- Double screw stay tightener - 2 Nos.
- C.I. stay plate - 2 Nos.
- Stay rod - 2 Nos.
- H.D.G. steel wire (stay wire) 7/16 SWG - 16m
- 50 x 12mm size M.S. bolts and nuts with washers - 2 Nos.
- Base plate for pole - 1 No.
- Casuarina pole of suitable height - 4 Nos.
- Wooden box of suitable size having 2 side openings for concrete pedestal - 1 No.

PROCEDURE

- 1 Select the place for fixing the pole near the building based on the span.
- 2 Select the type of pole to be erected. (Fig 1)

- 3 Dig a pit about 1/6th height of the pole having a diameter of minimum 3 times that of the dia of the pole bottom.
- 4 Prepare a mixture of concrete having a ratio 1:2:4 (one part cement, two part coarse sand and four part 2 cm blue metal chips) and pour the same in the bottom of the pit to a height of 15cms.
- 5 Ram the concrete and allow it to settle for a minimum period of 48 hours.
- 6 Keep the base plate for the pole at the bottom of the pit.
- 7 Fix a vertical straight pole on the plumb line in the pit. Refer (Fig 2)
- 8 Bring the pole and place it near the pit so that the bottom of the pole is at the edge of the pit.
- 9 Insert the wooden plank (board) vertically at one side of the pit facing opposite to the bottom portion of the pole.

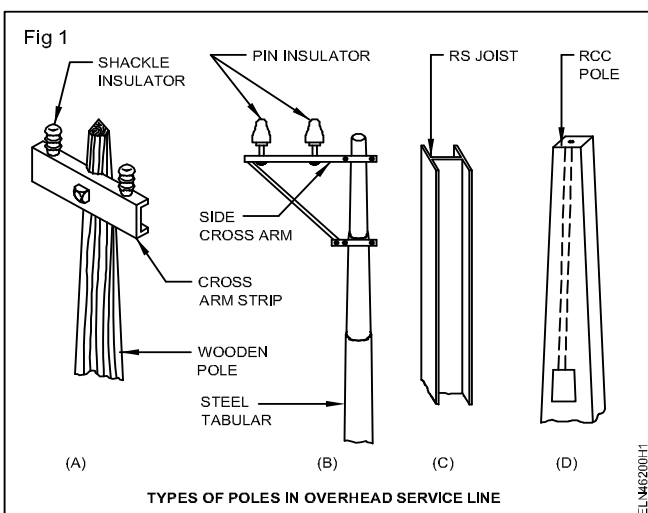

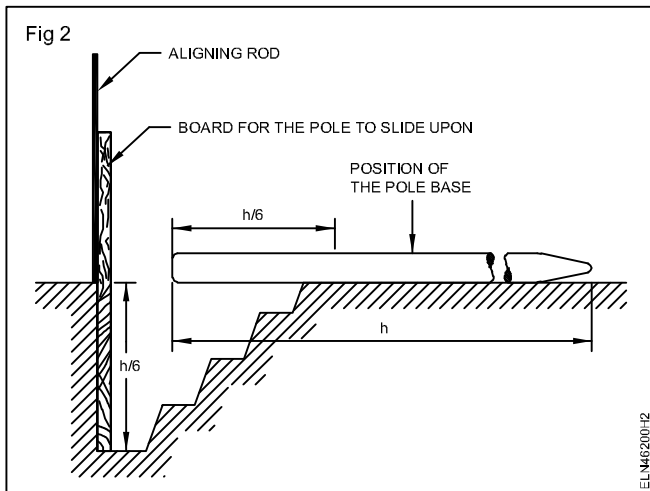

- 10 Fix the cross arms at the top of the pole below 30 cm from the top, with the help of 'C' clamps rigidly.
- 11 Tie the two ropes just below the cross arms.

Ensure that the cross arm is in the required direction

- 12 Place the casuarina pole at a distance of $\frac{1}{3}$ height of the top and also $\frac{1}{3}$ height from the bottom of the pole.
- 13 Prepare concrete mixture in the ratio of 1:3:4 (cement, sand and 1 cm blue metal chips).
- 14 Lift the pole step by step with the help of a rope and casuarina pole (Fig 3) and place it on the pit exactly vertical.
- 15 Check the vertical position with the help of an aligning a rod and plumb bob.
- 16 Pour the concrete mixture around the pole inside the pit and then place the wooden box around the pole.
- 17 Pour the concrete mixture in the box to a height of 0.5m above the ground level. Ram the mixture properly.
- 18 Cure the cement concrete for about 48 hours.

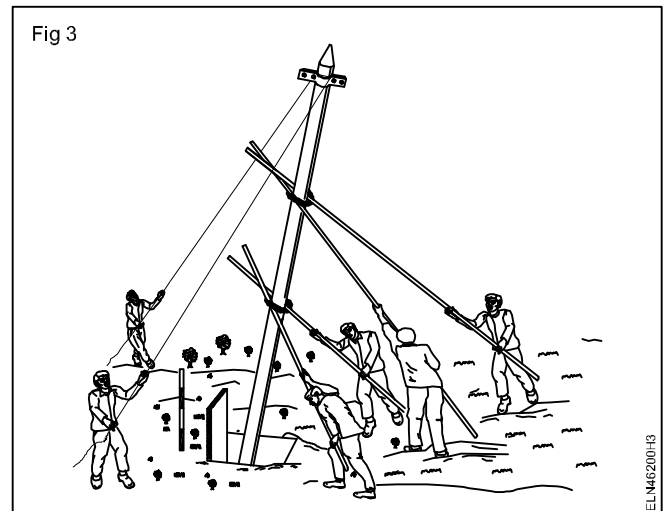

- 19 Remove the wooden box and plaster the cement concrete above the ground surface to have a smooth finish.
- 20 Fix the stay rod to the ground at a distance so as to get 45° to 60° between ground level and stay wire should be placed in the opposite direction to the line.
- 21 Cut the stay wire into 2 pieces of equal length.
- 22 Fix one end of each piece of the stay wire to the strain insulator (egg insulator).
- 23 Fix the other end of the second piece of stay wire to the stay. Tighten using a thimble.
- 24 Fix the stay and tighten to the stay.

Assuming the stay rod is fitted to the ground through a concrete structure which was sufficiently cured.

- 25 Tighten the stay tightener nut till there is no sag in the stay.

After drawing the overhead lines the stay should be tightened to compensate the tension of the overhead lines and to keep the pole in the vertical position.

Practice on laying of domestic service line

Objectives: At the end of this exercise you shall be able to

- locate the nearest pole, specify and estimate the quantity of materials required
- prepare the GI pipe, bend in the form of a goose neck and install it in position
- prepare the support GI wire with (ring insulator as) separators and service cable
- draw the service cable and connect it to the energy meter
- connect the service cable to the overhead lines through an aerial fuse
- earth the service cable support wire at both ends.

Requirements

Tools/Instruments

- Electrician tool kit - 1 No.
- Pipe jumper 25 mm dia. 40 cm length - 1 No.
- Pipe wrench 50 mm - 1 No.
- Megger 500V - 1 No.
- Rawl plug tool No.10 with bit - 1 No.
- Hacksaw adjustable with blade 300 mm - 1 No.
- Safety belt - 1 No.
- Bamboo ladder 6 m. height - 1 No.
- GI die set with stock 15 to 40 mm - 1 set

Materials

- Earth clips 40 mm - 6 Nos.
- Twin core service cable weather-proof or PVC sheathed insulated cable 2.5 sqmm., 250V grade - 20 m
- GI wire 10 SWG - 30 m
- GI wire 12 SWG and 22 SWG - 15m each

- GI wire 7/3.15 mm size - 5 m
- Porcelain ring insulator - 70 Nos.
- GI pipe 40 mm - 3 m.
- GI bends 40 mm - 1 No.
- MS clamps 40 mm, 3mm thick - 4 Nos.
- Wood screws 40 mm No.8 - 8 Nos.
- Silver paint 200 ml. - 1 No.
- Stay insulator - 2 Nos.
- Bombay nails - 8 Nos.
- Cable glands (heads) - as reqd.
- Bricks - as reqd.
- Sand - as reqd.
- Cable compound - as reqd.
- Solder - as reqd.
- Clamps for fixing cable - as reqd.

PROCEDURE

Drawing a service line is the work of the staff of the electricity board. Some of the trainees may get employment in state electricity board. When working on a service line it is utmost necessary to make a shut down before connecting the service cable to the service line.

- 1 Locate the nearest electrical pole and measure the distance from the pole to the building to which the service line is to be drawn (Fig 1) . Enter the measured value in Table 1.

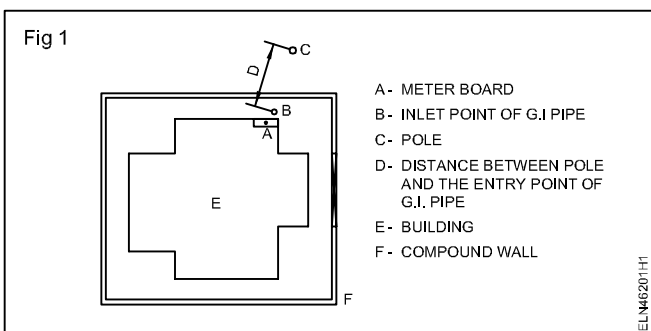

Care should be taken to see that the service cable does not cross the adjacent building area. In some cases an intermediate pipe structure may be needed to avoid crossing.

- 2 Identify whether the supply required for the house is single or 3-phase and enter it in Table 1.
- 3 Locate the position of the meter board and determine the height of GI pipe to be fixed for service connection. Refer to Fig 2, record the findings in the Table 1.

Preferably the entry height of the service cable of the GI Pipe should be at the height of the pole. If this is not possible due to the lower height of the house, arrange to fix the GI pipe at a maximum possible height.

- 4 Determine the length required for the goose neck bend and the thickness of the wall. Refer to Fig 2 and enter these particular in Table 1.

Normally a goose neck bend should have a diameter 12 times the diameter of the pipe. Say for a 25mm pipe the goose neck diameter will be $25 \times 12 = 300$ mm.

Table 1
Service connection measurements in metres for the supply of single/three phase

Distance between the pole and the entry point of the GI pipe D	Height of the GI pipeneck bend H	Length of the goose neck bend P	Wall thickness in mm T	Height of the meter L	Total length board
					<p>Length of the GI pipe H+P+T - (Length of bend)metres.</p> <p>Length of the GI wire as service line support wire. D+P+3 metres.</p> <p>Length of service cable</p> <p>Single phase = $[(D+H+P+T)L] 2$ + 10%</p> <p>3-phase = $[(D+H+P+T)L] 4$ + 10%</p>

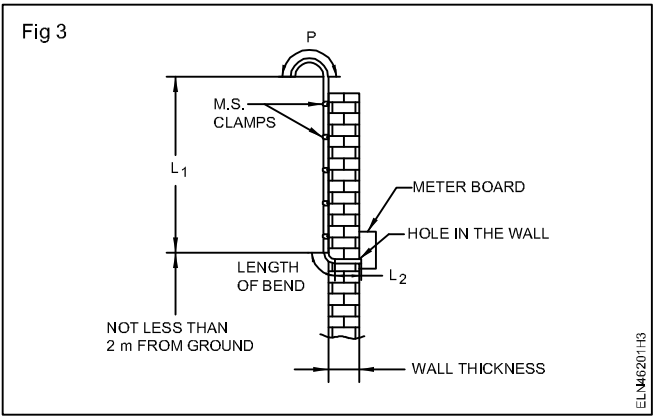
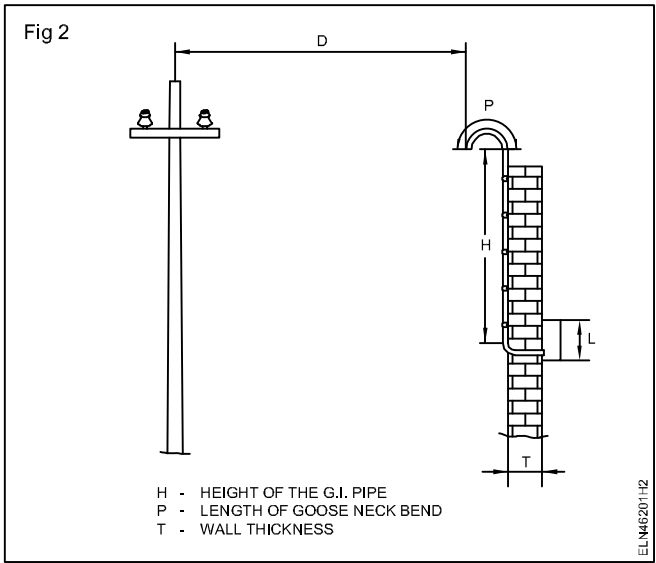

The hole should not be less than two metres from the ground.

- 5 Determine the length of the cable required from the inside wall to the meter terminals and enter the recorded measurements in Table 1. Calculate the required length of service cable and GI pipe from the above particulars and enter the values in Table 1.
- 6 Mark and cut two pieces of GI pipe of length L_1 and L_2 . Refer to Fig 3.
- 7 Thread the GI pipe of length L_1 and L_2 at one end.
- 8 Bend one end of the longer GI pipe L_1 to form the goose neck having a diameter equal to 12 times of the pipe diameter.
- 9 Make a hole in the wall with a pipe jumper such that the pipe when fitted is nearer to the energy meter terminals.

- 10 Fix the GI bend to the GI pipe. (Fig 3)
- 11 Pass the fish wire (GI wire of 20 SWG) through the assembled pipe.
- 12 Fix the GI pipe vertically to the wall using MS clamps. (Fig 3)

Use minimum one stay bow to the GI pipe in case the GI pipe has to be erected above the wall. Refer to (Fig 4a) and fix the other end of the stay bow to the eye bolt fixed to the roof.

- 13 Bind two numbers of the small ring insulators (separators) in the case of single phase supply, in one set by means of suitable GI wire of 20 SWG. (Fig 4b)

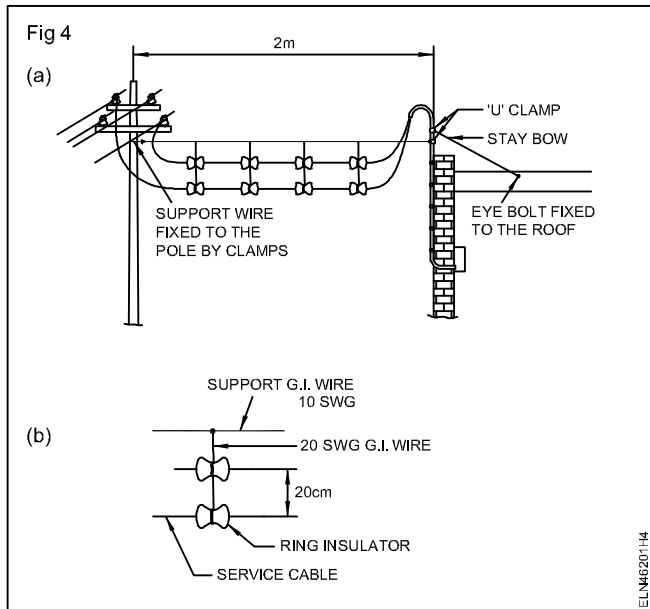

Keep 20 cm gap between the ring insulators for 250 volt and 30cm for 440 volt.

14 Bind such sets at a uniform distance to a main support G.I. wire of 10 SWG.

15 Pass the service wire (cable) through the ring insulators leaving sufficient length of wire for connection at both ends.

Mark the cables as phase and neutral at both ends.

16 Fix one end of the support GI wire to the vertical pipe, below the goose neck using 'U' clamps. (Fig 4a)

The 'U' clamp fixture should be sufficiently strong to withstand pull exerted by the weight of the service line and wind force.

17 Fix the other end of the support GI wire to the pole. (Fig 4a)

Use a ladder and wear a safety belt. Before climbing up the pole permission should be obtained from the electricity board and a shut down taken for safety.

18 Draw the service cables through the GI pipe by fish wire providing bushes at both ends of the pipe.

19 Connect the service lines to the energy meter and then to the cut outs.

20 Connect an earth continuity conductor (GI 12 SWG) between the 'U' clamp of the GI pipe and to the consumer main board earth terminal.

21 Provide earth clamps on the GI pipe for earthing.

22 Connect the phase cable of the service cable to the phase wire of the distribution line through a joint or by a connector.

In some electricity boards aerial fuses are introduced between the distribution line and the service cable. Follow the procedure as per the local regulation.

23 Connect the neutral cable of the service cable to the neutral wire of the distribution line through a joint or by a connector.

Service lines should be inspected by competent authority (EB) and the aerial fuse will be provided by them only.

24 Inspect the service line connections and then energise the line.

Install bus-bar and bus coupler on LT line

Objectives: At the end of this exercise you shall be able to

- **determine the location for installing bus bar and select the bus bar with bus coupler**
- **mount and fix the bus bar**
- **insert the plug -in-boxes in the bus bar system and also bus coupler**
- **test for earth continuity of bus bar and for insulation resistance.**

Requirements

Tools/Instruments

- Electrician tool kit - 1 No.
- DE spanner set (6 mm to 25 mm) - 1 Set
- Crimping tool - 1 Set
- Ladder with adjustable height - 1 No.
- High stool - 1 No.
- Hand hacksaw frame 300 mm - 1 No.
- Megger 500V - 1 No.

Materials

- Busbar of available current rating and standard length / current rating - 2 Nos.
- Plug - in boxes 32A - 2 Nos.
- Busbar brackets, M.S flat, for suspending - as reqd. the bus bar or GI pipe for supports and all supporting accessories
- Nut and bolts size and quantity for busbar extension standard accessories - as reqd.
- Bus coupler - 1 No.

PROCEDURE

- 1 Trace the workshop layout and calculate the total electrical capacity of machines, main power supply entry point and determine the rating.
- 2 Determine the busbar layout and the required length of the busbar.
- 3 Determine from the site what type of support is required to lay the busbar.
- 4 Mount and fix the busbars to the supporting structure. (Fig 1 and Fig 2).
- 5 Insert the plug - in-boxes in to the plug -in-points. (Fig 1)

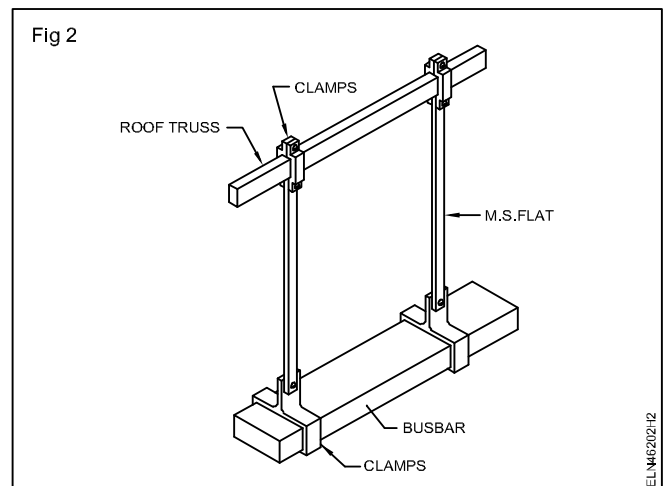
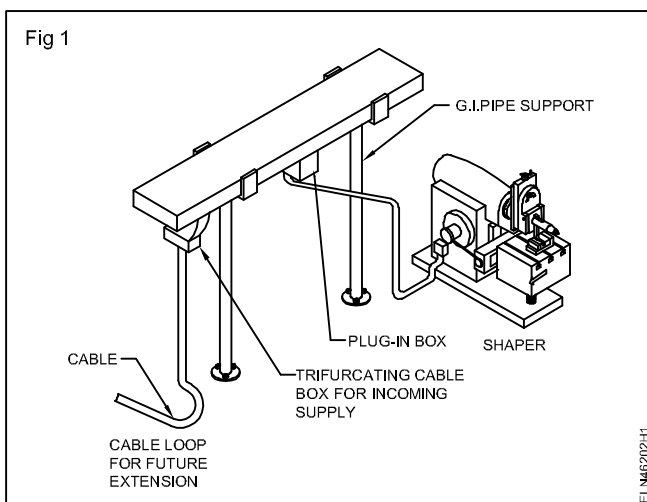

- 6 Couple the new busbar mechanically and electrically by using bus coupler, if another length is needed. (Fig 3)

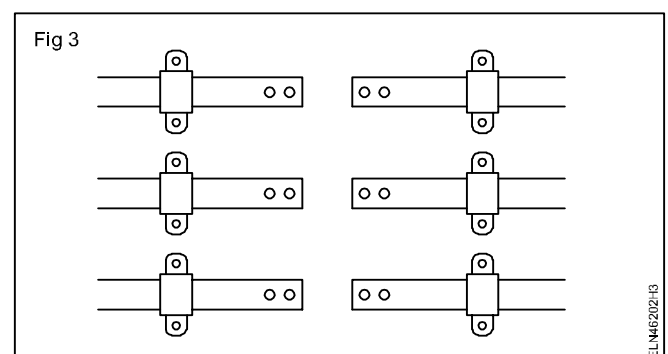

If any over lapping ends of the busbar join by bolting together.

7 Secure busbar with screws locking plates.

A connector - assembly which is commercially available comprises of

- rubber locating ring,
- busbar insulating tube

If connector insulating tube in knocked out condition. While coupling, make sure that the connector - assembly is properly secured.

- 7 Terminate the plug in boxes to the loads through metal conduit runs and suitable cables.
- 8 Test the bus bar system for earth continuity.
- 9 Test the system for continuity and insulations.
- 10 Connect the busbar to the incoming supply cable through trifurcating box. After ascertaining test results are OK. (Fig 3)

Identify various parts of relay and ascertain the operation

Objectives: At the end of this exercise you shall be able to

- identify the external controls and parts of a electromagnetic relay
- identify the external parts of the single pole over current relay.

Requirements			
Tools/Equipment			
• Trainees tool kit	- 1 No.	• Single pole over current/earth fault relay with instruction manual	- 1 No.

PROCEDURE

TASK 1 : Identify external controls and parts of a electromagnetic relay

- 1 Locate the relay parts provided in front of the relay (Fig 1) and identify the parts and fill in Table 1.
- 2 Note down the tap setting of current ranges at Table 2.
- 3 Note down in Table 2 the Indication displayed in the dial, multiplier along with percentage of fault current tripping time.
- 4 Locate the tripping. Flag indicator resetting level provided in front panel.

Once the relay tripped the flag will indicate a red line once it is tripped needs manual resetting by operating the lever.

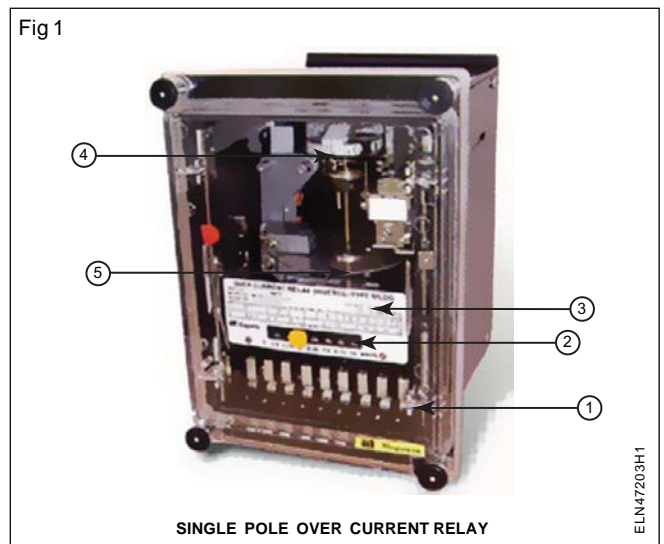

Table 1

Sl.No.	Part No.	Name of the external part	Function
1	1	Tripping flag indicator	Display tripping condition
2	2		
3	3		
4	4		
5	5		

Table 2

Sl.No	Current range	Multiplier of fault current	Time in seconds
1	Tap setting - 0.25A		

TASK 2 : Identify internal parts of a single pole over current relay

Instructor has to explain how to locate the internal parts and function of the circuit breaker and ask the trainees to tabulate the identified part of the available circuit breaker in your section.

- 1 Remove the front cover by loosening the four knobs provided in the corner of relay and preserve the cover with knobs carefully. (Fig 1)

Don't touch (or) try to operate any projected parts inside the relay.

- 2 Locate the aluminium disc fitted in the bottom of the spindle. (Fig 2)
- 3 Locate the Time Multiplier Setting (TMS) fitted in the top of the spindle.
- 4 Check the divisions marked on the TMS disc used for time setting.
- 5 Locate the spiral spring mounted on the top of spindle to bring back the disc to its original position after tripping.
- 6 Locate the moving contact fitted along with the spindle on the top of disc enabling tripping circuit.
- 7 Locate the two terminals contact points acting as a switch to trip the circuit.

Do not allow any dust or tiny particles enter inside. Dust will deposit in the pinion and effect the disc movement.

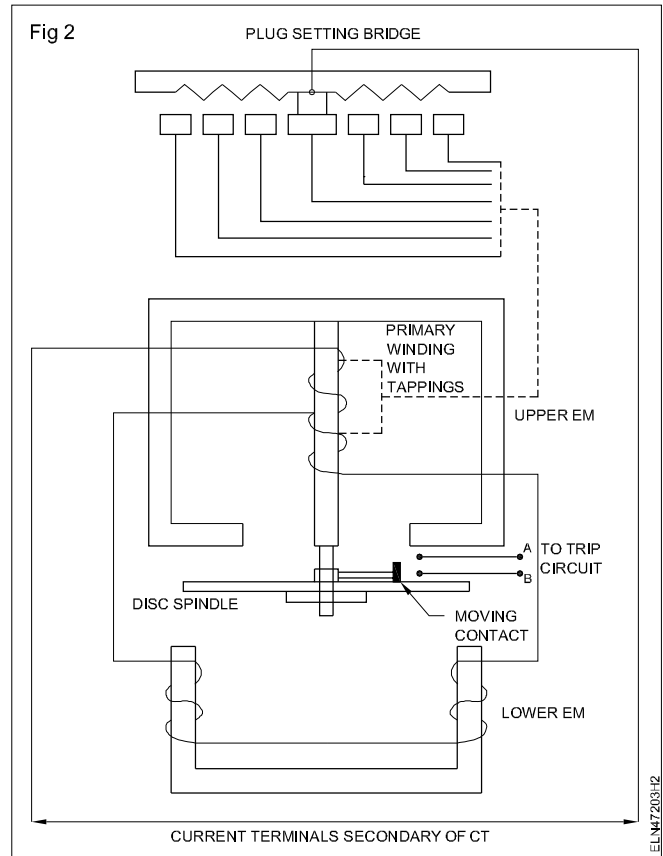

- 8 Close the front panel and show the findings to your instructor.
- 9 Note down the identified parts in Table 3.
- 10 Get it checked by your instructor.

Table 3

SI.No.	Part No.	Name of the internal part	Function

Practice setting of pick up current and time setting multiplier for relay operation

Objectives: At the end of this exercise you shall be able to

- calculate the fault current in different percentage
- set up current in injector unit for different fault current
- set the pick up current of a 50% fault current
- set the time multiplier for time setting under various fault condition.

Requirements			
Tools/Equipments			
• Trainees tool kit	- 1 No.	• Current injection unit with manual	- 1 No.
• Over current relay with manual (used in previous Ex.No.4.7.203)	- 1 No.		

PROCEDURE

TASK 1 : Identify of pickup current and tripp the relay for different fault current

- 1 Identify the supply voltage required for operating over current relay to its tripping coil.
- 2 Identify the current input terminals of relay.
- 3 Identify the shorting pins of NC/NO relay contacts.

Note : A sample reading is recorded in Table 1 on the tap setting at 1A; and multiplies value-2. Trip time displayed in dial an 10seconds

The current Injector unit is required to provide different fault current levels. The fault current settings is done in tap setting provided in the relay along with percentage of fault current with time.

Note : Select multiplier 2, so that the total fault current is 2 amp. ensure the time multiplier disc kept at position 1.

- 4 Connect the tripping coil voltage and fault current connections from current injector to relay as per the manual instruction. Keep all the controls at zero position in current injector unit.

- 6 Note down the corresponding time displayed on the dial for multiplier 2.

Some coils requires DC supply that can be taken from current injector unit.

The current injection unit have different makes and specifications . Energise the relay using manual supplied along with current injection unit.

- 5 Set the tap on relay for one amp. Calculate the multiplier from the dial and set the current in current injector unit. Record the values in Table 1.

- 7 Switch on the current injector unit ensure that relay is energised.

- 8 Increase slowly the current which is the input of relay to pickup.

Table 1

SI. No.	TMS Position	Tap set current (A)	Multiplier value	Time in seconds	Total fault current	Pickup current	Actual trip time
1	1	0.5	2 x 0.5 = 1A	10 Sec.	1A	<1A	
2	1	1.0					
3	1	1.5					
4	1	2.0					

- 9 Increase the current slowly, the disc of relay start to move that is the pickup current. Note down the value in Table 1.
- 10 Change the tap set current to some other current value and repeat the step 5 to 9.

- 11 Change the tap set for other value and repeat the steps 6 to 10 and record the readings.
- 12 Try few more tap set values and check the pickup current.

TMS position should not be changed while doing the exercise.

TASK 2 : Reduce the tripping time by setting time multiplier setting

- 1 Keep all the controls knobs at zero position.
- 2 Set the TMS disc at 0.5 position by rotating TMS disc fitted on the main spindle.

- 3 Repeat the steps 5 to 10 for the new TMS value of 0.5. Enter all the readings in Table 2.

Note : It may be noted that when TMS set for 0.5 the actual trip time reduced by 50% of the trip time actual in Task 1.

Table 2

Sl. No.	TMS Position	Tap set current (A)	Multiplier value	Time in seconds	Total fault current	Pickup current	Actual trip time
1	0.5	0.5 A	2 x 0.5 = 1A	10 Sec.	1A	<1A	
2	0.5	1.0 A					
3	0.5	1.5 A					
4	0.5	2 A					

Identify the parts of circuit breaker, check its operation

Objectives: At the end of this exercise you shall be able to

- identify the external parts of air circuit breaker
- identify the internal parts of air circuit breaker
- test the manual tripping of air circuit breaker.

Requirements		
Tools/Equipments		
<ul style="list-style-type: none"> • Trainees tool kit • Multimeter/ohm meter 	<ul style="list-style-type: none"> - 1 No. - 1 No. 	<ul style="list-style-type: none"> • Air circuit breaker 3 phase 415V maximum capacity 400 KA with instruction manual <p style="text-align: right;">- 1 No.</p>

PROCEDURE

TASK 1 : Identify the external parts and control switches of air circuit breaker

1 Verify the specifications of air circuit breaker with instructions manual. (Fig 1)

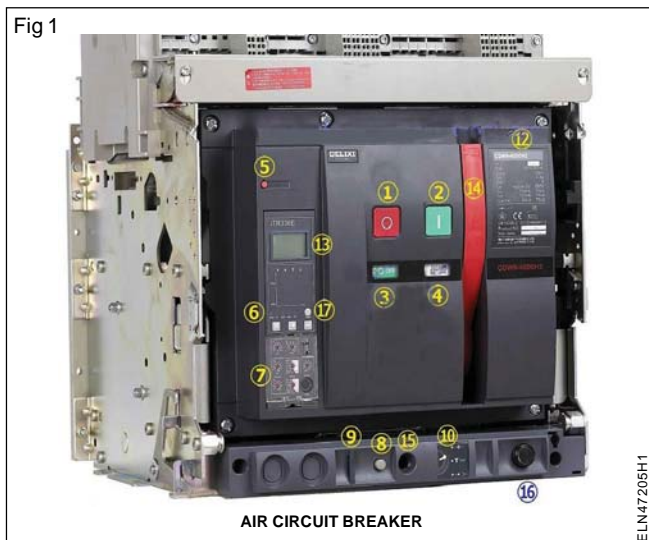

- 2 Identify the label numbers of the external part mentioned in Fig 1.
- 3 Write the corresponding label numbers against the corresponding external parts names only given in Table 1.

Table 1

Name of external parts

SI.No.	Parts label no	Name of the part
1	1	
2	2	
3	3	
4	5	
5	6	
6	7	
7	9	
8	13	
9	17	

Different makes of circuit breakers are available in the market. The air circuit breaker mentioned here is only a sample model for your guidance. The instructor may arrange the available model with necessary instructions if necessary.

4 Get it checked with your instructor.

TASK 2: Identify the internal parts of air circuit breaker

1 Remove the front cover carefully.

Do not remove any permanent parts of the breaker.

2 Identify the main internal parts (Fig 2) fitted in the breaker and note down in Table 2.

- 3 Locate the fixed main contact and movable main contacts.
- 4 Check the continuity of the contacts.
- 5 Locate the tripping coil terminals.
- 6 Remove the arcing chamber unit and test the arc chutes and diverters.

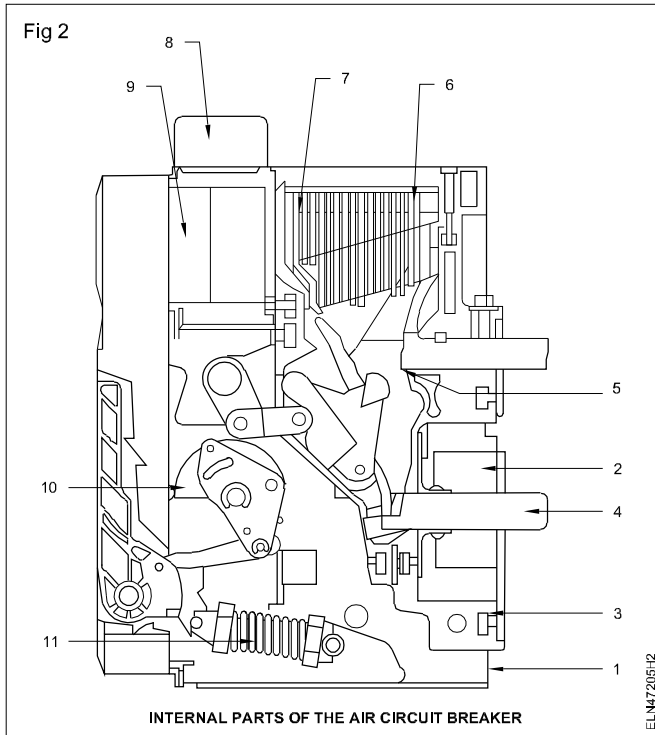

- 7 Locate the manual tripping lever to trip manually.
- 8 Connect the ACB to the main supply and switch ON.
- 9 Check the condition of indicating and tripping lamps.
- 10 Charge the breaker manually by operating handle.
- 11 Check the engaged main contact and confirm by checking its continuity.

- 12 Press the manual tripping switch and confirm its disengagement of the contacts.
- 13 Charge again the breaker and confirm the engagement of the main contacts.
- 14 Switch 'OFF' the AC mains, the arcing chamber and close the removed covers.
- 15 Submit the reports to your Instructor and get it approved.

Table 2
Name of internal parts

Sl. No	Parts no	Name of the part	Function
1			
2			
3			
4			
5			
6			
7			
8			
9			
10			
11			

Test tripping characteristic of circuit breaker for over current and short circuit current

Objectives: At the end of this exercise you shall be able to

- connect relay and circuit breaker for test tripping
- set the current injection unit for tripping current
- set the tripping current for definite time lag (over current)
- set the current for extreme inverse characteristic (short circuit current).

Requirements			
Tools/Equipments			
• Trainees tool kit	- 1 No.	• Over current relay with manual	- 1 No.
• Air circuit breaker 400 KA 415V with manual	- 1 No.	• Current injection unit with manual	- 1 No.

PROCEDURE

TASK 1: Tripping of circuit breaker for definite time with set fault current

This exercise is prepared to set the relay in definite time tripping in over current conditions and extreme inverse tripping in short circuit situations. This model relay is not having the facility of various tripping characteristics.

However short circuit current situation can be provided to trip the relay in short time by setting Time Multiplier Setting (TMS) to trip the relay instantly at high fault current situation.

- 1 Connect the relay, circuit breaker with the current injection unit by referring in block diagram. (Fig 1)

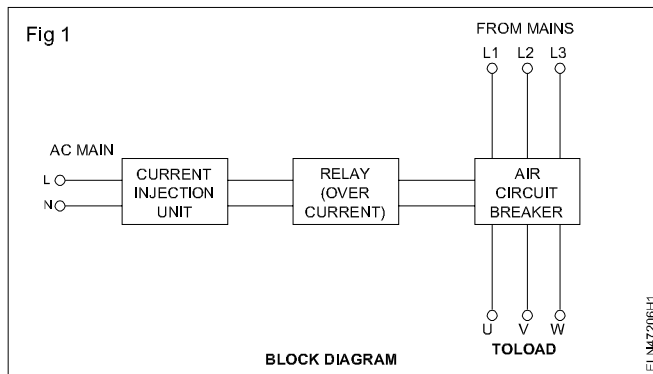

- 2 Check all the connections as per the instruction manual.
- 3 Set the tap setting current in 1 amp and note down the multiplier, time in seconds in Table 1.
- 4 Set the TMS at position 1 marked in the dial.
- 5 Check the pick up current of the set value of tap setting current and note down values in table 1.
- 6 Set the fault current by selecting multiplier from the dial and note corresponding time in seconds and note the values in Table 1.

Now the fault current set value is 2 Amp and the relay should trip in the time as per the dial indication.

- 7 Switch 'ON' the current injection and note down the tripping indicated by the timer fitted on the current injection unit.
- 8 Reduce the time by setting TMS by 0.5.

Since the short circuit current cannot be generated practically the tripping time is reduced by taking the short circuit current is present now.

- 9 Ensure the rotating aluminium disc returns to its original position.
- 10 Switch ON the injection unit and note down the tripping time in seconds.

This time will be half time of the first reading.

- 11 Change the tap setting at 2 amps slot in the relay and repeat the steps 4 to 9.
- 12 Record the readings in the table and get it approved by your instructor.

Table 1

Test tripping of circuit breaker definite time charts

Sl. No	Tap setting current	TMS value	Time	Multiplier	Total fault current	Actual tripping current	Error in %
1							
2							
3							
4							

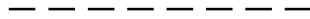

TASK 2: Tripping circuit breaker in extreme inverse characteristic condition

- 1 Repeat the step 1 to 3 in Task 1.
- 2 Set the TMS at 0.2 position.
- 3 Set the tap setting plug into maximum current input on the dial.
- 4 Select the maximum multiplier value in the dial record the fault current (plug set value 'X' multiplier) and the tripping time in Table 2.
- 5 Check the pickup current for the tap set value.
- 6 Set the fault current in the current injector unit
- 7 Switch 'ON' and note down the actual tripping time in Table 2.
- 8 Try to some higher value of fault current and repeat the step 5 to 7. Record the values in Table 2.

Table 2

Extreme inverse charts

Sl. No	Tap setting current	TMS value	Time	Multiplier	Total fault	Actual tripping	Error in %
1							
2							
3							
4							



Practice on repair and maintenance of circuit breaker

Objectives: At the end of this exercise you shall be able to

- follow the shut down procedure
- refer to service and operating manuals of a given circuit breaker to identify the parts and their functions (R)
- refer to previous maintenance records for carrying out routine maintenance checks
- locate the faulty part and replace it
- follow the general maintenance procedure on the circuit breaker.

Requirements		
<p>Tools/Instruments</p> <ul style="list-style-type: none"> • Insulated cutting pliers 150 mm - 1 No. • Screwdriver 150 mm - 1 No. • Heavy duty screwdriver 300 mm - 1 No. • Neon tester 150 mm 600V - 1 No. • D.E. spanner set of 9 Nos. 5 mm to 20 mm - 1 Set • Box spanner set of 9 Nos. 5 mm to 20 mm - 1 Set • Megger 500V - 1 No. • Multimeter 20 kilo ohm/volt - 1 No. • Cleaning brush round 2.5 cm - 1 No. • Plumb bob with thread - 1 No. • Spirit level 300 mm - 1 No. • Flat file bastard 250 mm - 1 No. 	<p>Equipment/Machines</p> <ul style="list-style-type: none"> • Circuit breaker of higher voltage and current rating - 1 No. <p>Materials</p> <ul style="list-style-type: none"> • Rubber or cork gasket as specified and reqd. • Sand paper Grade "0" - 1 Sheet • Grease - 10 g. • Flexible cable 14/0.2 - 5 mts. • Dash pot oil of specific grade - 200 ml. • Contact cleaner oil - CRC 2-26 - 1 bottle • Electro tube - 25 g. 	

PROCEDURE

As it is impracticable to get a switch gear of high voltage and current rating in a vocational institute, it is recommended that the trouble shooting procedure is followed in a circuit breaker, having similar facilities like the rotor resistance starter used in a slip ring induction motor. However, the manufacturers instruction for the trouble-shooting should be followed for larger circuit breakers when the trainee is employed in an industry. The working steps given there are of a generalized nature and could be used with slight modification for any circuit breaker.

Caution: Before taking up the maintenance work on any circuit breaker which is in operation, it is utmost necessary to take permission from the engineer in-charge. He only decides whether alternative arrangement is required to maintain supply to the consumer or a shut down is to be effected.

Permission for shut down is given by the engineer in the approval forms. Follow all the instructions contained in the shut down form before taking up the maintenance work on the circuit breaker. The concerned control switch of the circuit breaker should be switched OFF and locked and caution boards should be displayed in the control panel. The key should be kept in the custody of the engineer in-charge. A caution board should also be displayed predominantly near the circuit breaker which is under maintenance.

- 1 Collect the service and operating manuals of the circuit breaker and read them carefully.
- 2 Collect the maintenance record sheet of the circuit breaker.

It is desirable that you read the service and operating manuals carefully and thoroughly before starting the actual maintenance work.

- 3 Note the name-plate details of the circuit breaker in Table 1.

Example of work permit and shut down

- 4 Switch 'OFF' the incoming and outgoing bus bars, and then disconnect the circuit breaker from the bus bars.
- 5 Follow the instructions contained in the service manual to open the top covers of the circuit breaker.

- 6 Identify the parts and compare with the service manual.
- 7 Identify and trace the tripping circuits.
- 8 Carefully inspect the parts for burnt smell, visible indication of burns, pittings and discolouring.
- 9 Interpolate your finding with the maintenance record sheet information to pin point the faulty part.
- 10 Identify the part number from the service manual and draw the parts from the stores.

- 11 Check the correctness of the part received from the stores and then replace the part in the circuit breaker.

General maintenance procedure

- 12 Check the mounting bolts/studs for correct tightness.
- 13 Check the verticality of the circuit breaker with the help of a plumb bob, and horizontality with the help of spirit level.

If necessary correct them by mounting bolts.

Table 1

Technical data of the circuit breaker

i	Type of the circuit breaker
ii	Type designation
iii	No. of phases/poles
iv	Rated voltage
v	Maximum voltage
vi	Rated frequency
vii	Rated current
viii	Rated symmetrical breaking capacity
ix	Rated making current
x	Rated short time current
xi	Quantity of oil per pole
xii	One minute try withstand voltage
xiii	Impulse withstand voltage
xiv	Type of closing device
xv	Trip free/fixed trip
xvi	Weight of the oil
xvii	Quantity of oil in litres
xviii	Nett weight of the circuit breaker with oil in kg
xix	Overall dimensions of OCB mounted on frame
xx	Ambient temperature for which OCB is designed
xxi	Auxiliary voltage for shunt trip coils
xxii	Auxiliary voltage for under-voltage release
xxiii	Auxiliary supply voltage for motor drive

- 14 Check the stationary, fixed, arcing, intermediate and main contacts. Clean them with a steel wire brush or sandpaper grade '0' to remove any deposit due to oxidation. Figs 1 and 2 are given for your guidance.

If pittings are heavy, use a flat file to remove the pittings. If the surface area is reduced more than ten percent due to pittings it will be better to replace the contact points.

- 15 Clean the contact by using CTC solution.
- 16 Check the internal control wiring along with the given wiring diagram of the manual.

- 17 Use a continuity tester to test the continuity of each wire from point to point.

If the internal wiring cables are damaged replace them. Check for loose terminations and tighten them.

- 18 Measure the trip coil resistance and compare with the earlier measurement.

There should not be any change in coil resistance.

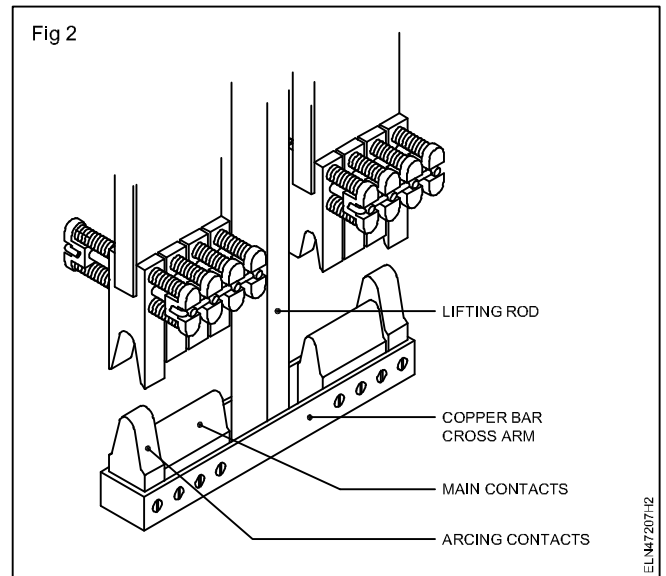
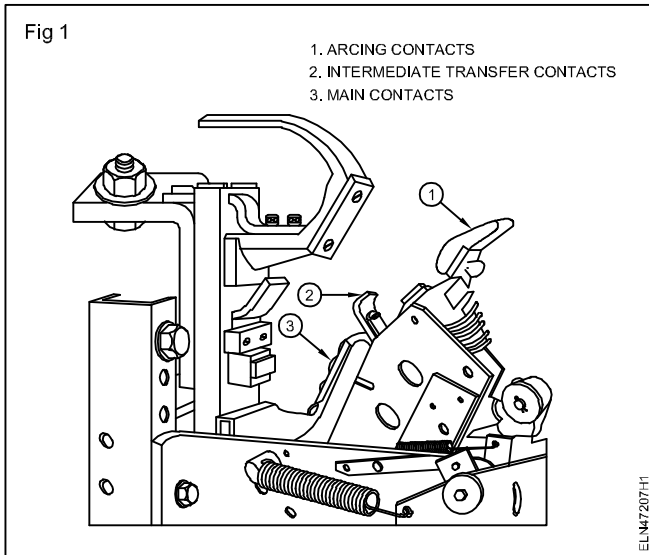

19 Check that the tripping rod and the armatures of the tripping releases, move freely without blocking or friction.

20 Circuit breaker regular maintenance record sheet model given in Table 2.

If the releases are found to be under friction clean the relevant part thoroughly.

Table 2

Maintenance record sheet for circuit breaker

Sl.No.	Date	Particulars	Complained by	Attended by	Description of fault	Particulars of replacement	Signature of the engineer in-charge
1							
2							
3							
4							
5							

Project work

Objectives: The Trainees/Participants shall be able to

- **select a project work of their choice**
- **prepare the list of materials required and collect them**
- **list out the tools required**
- **prepare a brief note on the project**
- **complete the project and submit the project report with all the details.**

Note: Instructor has to explain in detail regarding the project works to be carried out in the section. The trainees may be divided in groups according to the strength available in section and give all details how to prepare and finish the work with complete workmanship and accuracy.

- Step to start and follow the project work
- Motivate the group by emphasising the technical work involved and its future influences.
- Divide the work equally and make sure in yoke participating with full interest.
- Start the project work, test it stage by stage and complete it.
- Test the completed project job for its functionality and its utility.
- Prepare a project report containing its technical parameters, specification, material requirement and its cost, operational procedure, maintenance, utility and marketing etc.
- Indicate the scope of future expansion, easy conversion to other project for advanced version in the report.
- Get it checked with your instructor.

The project should be completed with all operational with instructions necessary procedure.

Safety devices are to be placed according to the project and its functions.

Maintenance and repair instructions should be indicated clearly.

Note: Instructor has to evaluate the project work with all records and reports. Marks to be awarded for the project working, accuracy, workmanship, safety features and its work performance related to the viva questions.

Project works

- 1 Battery charger/Emergency light
- 2 Control of motor pump with tank level
- 3 DC voltage converter using SCRs
- 4 Logic control circuits using relays
- 5 Alarm/indicator circuits using sensors

Note :

- 1 Some of the sample project works (indicative only) are given against each semester.
- 2 Instructor may design their own project and also inputs from local industry may be taken for designing such new project.
- 3 The project should proudly cover maximum skills in the particular trade and must involve some problem solving skill. Emphasis should be on Teamwork: Knowing the power of synergy/collaboration, work to be assigned in a group (Group of at least 4 trainees). The group should demonstrate Planning, Execution, Contribution and Application of Learning. They need to submit Project report.
- 4 If the instructor feels that for execution of specific project more time is required than he may plan accordingly to produce components /sub-assemblies in appropriate time i.e., may be in the previous semester or during execution of normal trade practical.