

DIRECTORATE GENERAL OF TRAINING (DGT)
ALL INDIA TRADE TEST, MAINS AUG 2026
CRAFTSMEN TRAINING SCHEME (CTS)
TRADE PRACTICAL EXAMINATION

TRADE: FITTER (NSQF), 1st YEAR
SUBJECT: TRADE PRACTICAL
TRADE CODE: 453
PAPER CODE: 26/08/C/A-1/2

Date: 17/06/2026
Time: 8 Hrs
Max. Marks: 250
Min. Marks: 150

Note: Attempt all questions.

- 1) a. Write down the list of tools, instruments and equipment required to perform the practical. (5 Marks) (250 Marks)
- b. Write down the job sequence of operation to perform the practical along with the safety related information. (10 Marks)
- c. Make the job as per drawing given below. (235 Marks)

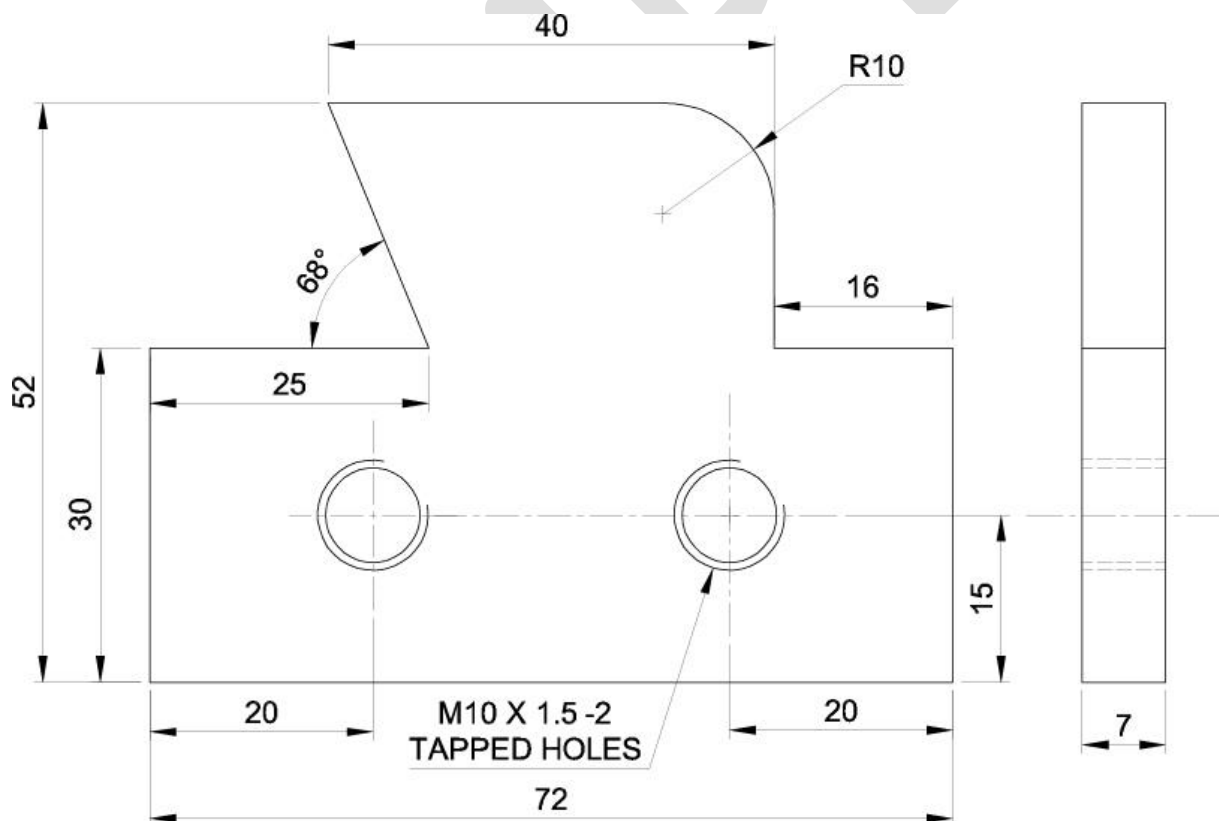

ALL DIMENSIONS ARE IN mm
TOLERANCE ± 0.04 mm
ANGULAR TOLERANCE $\pm 30'$