

All India Trade Test - 2024 for Craftsmen Training Scheme (CTS)

Trade Name: Turner _ Year 2

Year: 2nd Year

Exam Date :
Exam Time :

Note:

1. Tick the correct option out of four alternatives provided
2. All questions carry equal marks (2 Marks each)
3. There is no negative marking

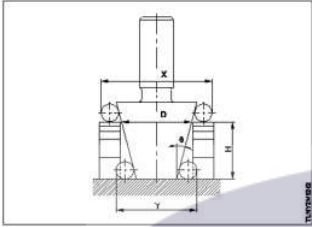
Sr. No.	Client Question ID	Question Body and Alternatives	Marks	Negative Marks
Trade Theory				
1	1	<p>What is the use of formula in taper measurement? टेपर माप में सूत्र का क्या उपयोग है?</p> $\tan \theta = \frac{X - Y}{2H}$  <p>A1 Checking the angle of taper : टेपर कोण को ज्ञात करना</p> <p>A2 Finding small end diameter : छोटे व्यास को ज्ञात करना</p> <p>A3 Finding large end diameter : बड़े व्यास को ज्ञात करना</p> <p>A4 Finding the length of taper : टेपर की लम्बाई को ज्ञात करना</p>	2.0	0.00
Trade Theory				
2	2	<p>Calculated the rpm of spindle if cutting speed 'V' is 120m/min and the diameter 'D' of the job is 50 mm? स्पिंडल के चक्कर प्रति मिनट (RPM) की गणना कीजिये जबकि कटिंग गति 'V' 120 मीटर/मिनट एवं जॉब का व्यास 'D' 50 mm है।</p> <p>A1 500 rpm : 500 rpm</p> <p>A2 764 rpm : 764 rpm</p> <p>A3 856 rpm : 856 rpm</p> <p>A4 975 rpm : 975 rpm</p>	2.0	0.00
Trade Theory				
3	3	<p>Calculate the spindle speed to turn a 40mm dia M.S rod using a cemented carbide tool it cutting speed is 92mm/min? मृदु लोहे का 40 mm व्यास के जॉब में सीमेन्टेड कार्बाइड के टूल का उपयोग कर स्पिण्डल की गति की गणना करें। जबकि कटिंग स्पीड 92 मिमी / मिनट है ?</p>	2.0	0.00

		<p>A1 : 508 rpm 508 rpm</p> <p>A2 : 685 rpm 685 rpm</p> <p>A3 : 732 rpm 732 rpm</p> <p>A4 : 950 rpm 950 rpm</p>		
Trade Theory				
4	4	<p>Calculate the length of metal passing by cutting tool in one revolution if the diameter of work is 75mm and cutting speed is 120m/min. एक परिक्रमण में गुजरने वाली धातु की लंबाई की गणना करें यदि जॉब का व्यास 75 mm है और काटने की गति 120 m/min है।</p> <p>A1 : 235.5 mm 235.5 mm</p> <p>A2 : 295.7 mm 295.7 mm</p> <p>A3 : 365.3 mm 365.3 mm</p> <p>A4 : 485.7 mm 485.7 mm</p>	2.0	0.00
Trade Theory				
5	5	<p>Find out the R.P.M of spindle for a 50mm bar (D) and cutting speed is 25m/min. 50 मिमी 'D' की छड (बार) एवं 25m/min कटिंग गति हेतु स्पिंडल के RPM को ज्ञात करें?</p> <p>A1 : 100rpm 100rpm</p> <p>A2 : 159rpm 159rpm</p> <p>A3 : 168rpm 168rpm</p> <p>A4 : 250rpm 250rpm</p>	2.0	0.00
Trade Theory				
6	6	<p>What is the name of work holding device were the irregular work could hold in lathe? आसमान कार्यो को लेथ मशीन मे पकड़ने वाले डिवाइस का क्या नाम है?</p> <p>A1 : Face plate फेस प्लेट</p> <p>A2 : Catch plate केच प्लेट</p> <p>A3 : B-Jaw chuck बी-जॉ चक</p> <p>A4 : Driving place ड्राइविंग प्लेट</p>	2.0	0.00
Trade Theory				
7	7	<p>What is angle between the two faces of angle plate? कोणीय प्लेट की दो फेस के मध्य कोण कितना होता है?</p>	2.0	0.00

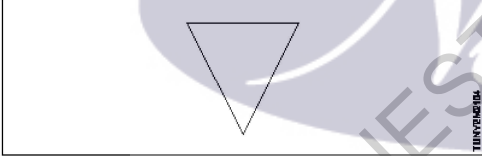
		A1 30° : 30° A2 45° : 45° A3 60° : 60° A4 90° : 90°		
Trade Theory				
8	8	How the roughness value is expressed? खुरदरापन वैल्यू कैसे व्यक्त किया जाता है? A1 Micrometer : माइक्रोमीटर A2 Millimeter : मिलीमीटर A3 Centimeter : सेंटीमीटर A4 Meter : मीटर	2.0	0.00
Trade Theory				
9	9	What is the roughness grade number for symbol? सिंबल के लिए रफनेस ग्रेड संख्या क्या होता है?  A1 N1 to N3 : N1 to N3 A2 N4 to N6 : N4 to N6 A3 N11 : N11 A4 N12 : N12	2.0	0.00
Trade Theory				
10	10	What is the roughness value of grade No N1? ग्रेड नंबर एन 1 का खुरदरापन मान क्या है? A1 6.3 microns : 6.3 माइक्रोन A2 0.025 microns : 0.025 माइक्रोन A3 12.5 microns : 12.5 माइक्रोन	2.0	0.00

A4 0.4 microns
 :
 0.4 माइक्रोन

Trade Theory

11 11

What is the value of "b" in the surface roughness symbol?
 सतह खुरदरापन प्रतीक में "b" का मान क्या है?

2.0

0.00

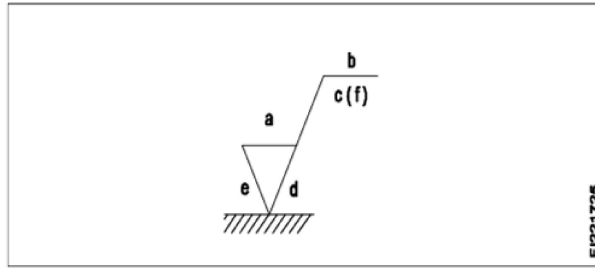

A1 Roughness grade
 :

रफनेश ग्रेड

A2 Sampling length
 :

सेपलिंग लंबाई

A3 Production method
 :

उत्पादन की विधि

A4 Direction of lay
 :

ले की दिशा

Trade Theory

12 12

Which material used for manufacturing marking table?
 मार्किंग टेबल के निर्माण के लिए किस सामग्री का उपयोग किया जाता है?

2.0

0.00

A1 Cast iron
 :

कास्ट आइरन

A2 Aluminum
 :

एल्युमिनियम

A3 Tool steel
 :

टूल स्टील

A4 Mild steel
 :

माइल्ड स्टील

Trade Theory

13 13

What is the term used to represent the value marked as 'E'?
 'E' द्वारा चिह्नित चिह्न को प्रदर्शित करने के लिए किस शब्द का उपयोग करते हैं?

2.0

0.00

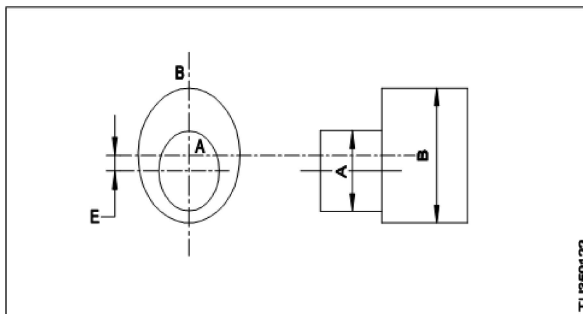

A1 Throw
 :

थ्रो

A2 Eccentricity

:
विकेन्द्रता

A3 Concentricity

:
केंद्रीकरण

A4 Step length

:
स्टेप लंबाई

Trade Theory

14

14

What is the formula for calculating throw in an eccentric turned component?
विकेन्द्रता टर्न कॉम्पोनेंट में थ्रो की गणना करने का फॉर्मूला क्या है?

2.0

0.00

A1
:

$$\text{Throw} = \frac{E}{2}$$

A2
: Throw = E

$$\text{Throw} = E$$

A3
: Throw = 2 x E

$$\text{Throw} = 2 \times E$$

A4
: Throw = 3 x E

$$\text{Throw} = 3 \times E$$

Trade Theory

15

15

What is the formula for eccentricity in a job?
जॉब की विकेन्द्रता हेतु सूत्र क्या है ?

2.0

0.00

A1
:

$$E = \frac{\text{Throw}}{2}$$

A2
: E = 2 x Throw

$$E = 2 \times \text{Throw}$$

A3
: E = 3 x Throw

$$E = 3 \times \text{Throw}$$

A4
:

$$E = \frac{\text{Throw}}{4}$$

Trade Theory

16

16

What is the type of angle plate?
यह किस प्रकार की कोणीय प्लेट है?

2.0

0.00

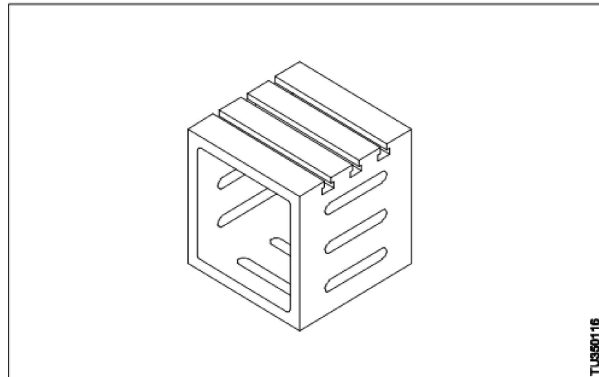

TLSS0116

A1 Plain

:

प्लेन

A2 Box

:

बॉक्स

A3 Swivel

:

घूमने वाला

A4 Slotted

:

स्लोटेट

Trade Theory

17

17

What is the name of angle plate?

2.0

0.00

यह किस प्रकार की कोणीय प्लेट है?

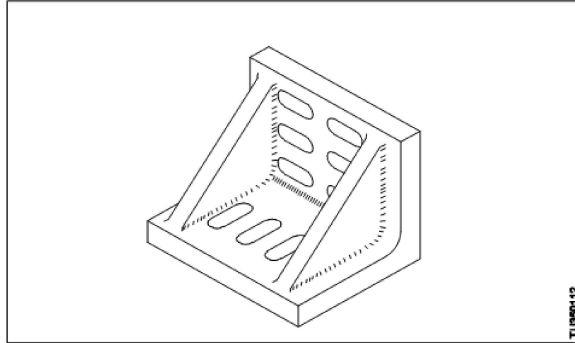

A1 Plain angle plate

:

प्लेन कोणीय प्लेट

A2 Slotted angle plate

:

स्लोटेट कोणीय प्लेट

A3 Box angle plate

:

बॉक्स कोणीय प्लेट

A4 Swivel type angle plate

:

घूमने वाली कोणीय प्लेट

Trade Theory

18

18

What is name of angle plate?

2.0

0.00

यह किस प्रकार की कोणीय प्लेट है?

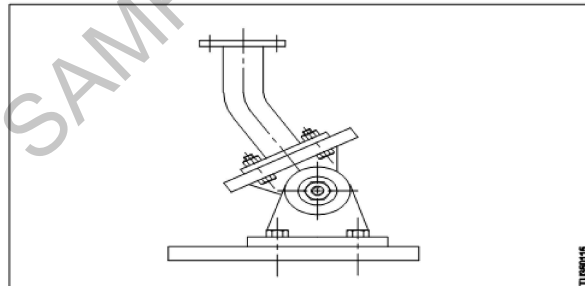

A1 Plain

:

प्लेन

A2 Box type

:

बॉक्स

A3 Slotted

:

स्लोटेट

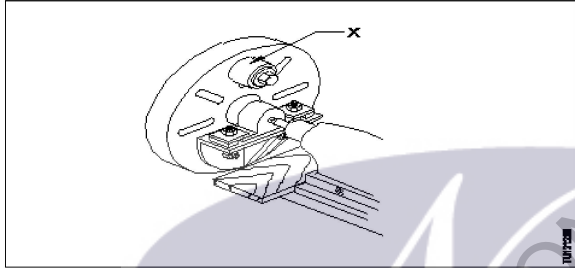
		A4 Swivel type : घूमने वाला		
Trade Theory				
19	19	Which lathe accessory is used to clamp the fixture? फिक्सचर को क्लैम्प करने के लिए कौनसे उपसाधन का उपयोग करते हैं? A1 3 jaw chuck : 3 जॉब चक A2 4 jaw chuck : 4 जॉब चक A3 Face plate : फ़ेस प्लेट A4 Collet chuck : कोलेट चक	2.0	0.00
Trade Theory				
20	20	What is the part marked as 'X'? 'X' के रूप में चिह्नित भाग का नाम क्या है?  A1 Angle plate : कोणीय प्लेट A2 Face plate : फ़ेस प्लेट A3 Counter weight : काउंटर वजन (प्रतिभार) A4 Work piece : वर्क पीस	2.0	0.00
Trade Theory				
21	21	Which lathe part is used to mount the dial indicator for truing the bore? बोर को दुरु करने के लिए डायल इंडिकेटर को लेथ मशीन के किस भाग में बांधते हैं? A1 Tail stock : टेल स्टॉक A2 Cross side : क्रॉस स्लाइड A3 Tool post : टूल पोस्ट A4 Lathe bed : लेथ बेड	2.0	0.00
Trade Theory				
22	22	What is the name of device marked as 'X'? 'X' के रूप में चिह्नित डिवाइस का नाम क्या है?	2.0	0.00

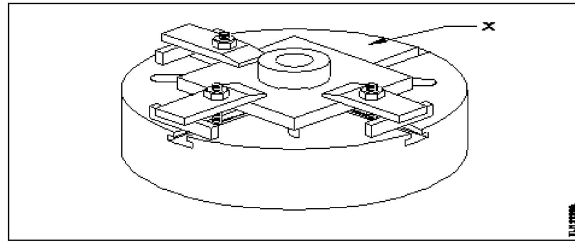

A1 Lathe plate

:

लेथ प्लेट

A2 Four jaw chuck

:

4 जॉब चक

A3 Faceplate

:

फ़ेस प्लेट

A4 Driving plate

:

ड्राइविंग प्लेट

Trade Theory

23

23

How may roughness grade number are used?
कितने खुरदरे ग्रेड नंबर का उपयोग किया जाता है?

A1 N1 to N12

:

N1 से N12

A2 N1 to N25

:

N1 से N25

A3 N1 to N20

:

N1 से N20

A4 N1 to N30

:

N1 से N30

Trade Theory

24

24

What is the name of precision finishing operation carried out by using fine abrasive materials?
फ़ाइन घर्षक प्रदार्थ का उपयोग कर परिशुद्ध सतह प्राप्त करने की संक्रिया को क्या कहते हैं?

A1 Grinding

:

ग्राइंडिंग

A2 Lapping

:

लेपिंग

A3 Filing

:

फिलिंग

A4 Polishing

:

पोलिशिंग

Trade Theory

25

25

What is lapping?
लेपिंग क्या है?

A1 Precision finishing operation

:

सटीक परिष्करण संक्रिया

A2 Filing operation

:

फिलिंग संक्रिया

2.0

0.00

2.0

0.00

2.0

0.00

		<p>A3 Grinding operation : ग्राइंडिंग संक्रिया</p> <p>A4 Chiseling operation : चीसलिंग संक्रिया</p>		
Trade Theory				
26	26	<p>Which lapping material used for easy charging and rapid cutting? आसान चार्जिंग और रैपिड कटिंग के लिए किस लैपिंग सामग्री का इस्तेमाल किया जाता है?</p> <p>A1 Cast iron : कास्ट आयरन</p> <p>A2 Copper and brass : तांबा एवं पीतल</p> <p>A3 Close grained iron : क्लोज्ड ग्रेन आयरन</p> <p>A4 White cast iron : सफ़ेद कास्ट आइरन</p>	2.0	0.00
Trade Theory				
27	27	<p>Which lap material inexpensive and can be expanded if worn out? कौन सी लैप सामग्री सस्ती है और अगर खराब हो जाए तो इसका विस्तार किया जा सकता है?</p> <p>A1 Brass : पीतल</p> <p>A2 Cast iron : कास्ट आयरन</p> <p>A3 Lead : सीसा</p> <p>A4 Bronze : काँसा</p>	2.0	0.00
Trade Theory				
28	28	<p>What is the purpose of preventive maintenance? निवारक मैटेनेंस का उद्देश्य क्या है?</p> <p>A1 Maintain machine in good working order : अच्छा कार्य क्रम में मशीन बनाए रखने के लिए</p> <p>A2 Increase the cost of inspection : निरीक्षण की लागत में वृद्धि हेतु</p> <p>A3 Reduce the vibration of machine : मशीन का कंपन कम करने के लिए</p> <p>A4 To keep the maintenance records : मैटेनेंस रिकॉर्ड रखने के लिए</p>	2.0	0.00
Trade Theory				
29	29	<p>How can the unexpected breakdowns of machines reduced? मशीनों के अप्रत्याशित टूटने को कैसे कम किया जा सकता है?</p> <p>A1 By preventive maintenance : निवारक मैटेनेंस द्वारा</p> <p>A2 By break down maintenance : ब्रेकडाउन मैटेनेंस द्वारा</p>	2.0	0.00

		<p>A3 : By productive maintenance उत्पादक मैटेनेंस द्वारा</p> <p>A4 : By quality maintenance गुणवत्ता मैटेनेंस द्वारा</p>		
Trade Theory				
30	30	<p>What is the advantage of maintenance records? मैटेनेंस के रिकॉर्ड के क्या फायदा है?</p> <p>A1 : Reduce the clerical work लिपिकीय कार्य कम करें</p> <p>A2 : Monitor the frequent breakdown बार-बार टूटने की निगरानी करें</p> <p>A3 : Increase the cost of production उत्पादन की लागत में वृद्धि</p> <p>A4 : Zero breakdown maintenance शून्य ब्रेकडाउन मैटेनेंस</p>	2.0	0.00
Trade Theory				
31	31	<p>Which device is used as a reference surface for marking? किस उपकरण को अंकन के लिए संदर्भ सतह के रूप में उपयोग किया जाता है?</p> <p>A1 : Angle plate एंगल प्लेट</p> <p>A2 : Marking table मार्किंग टेबल</p> <p>A3 : Anvil एनविल</p> <p>A4 : Lathe bed लेथ बेड</p>	2.0	0.00
Trade Theory				
32	32	<p>Which type of instrument is generally used to check eccentricity? विकेंद्रता को जाचने के लिए किस प्रकार के उपकरण का उपयोग करते हैं?</p> <p>A1 : Dial test indicator डायल टेस्ट इंडिकेटर</p> <p>A2 : Micrometer मिक्रोमीटर</p> <p>A3 : Surface gauge सरफेस गेज</p> <p>A4 : Vernier calipers वर्नियर कैलिपर</p>	2.0	0.00
Trade Theory				
33	33	<p>Which type of angle plate is used to hold work at an angle? जॉब को कोण में पकड़ने के लिए किस प्रकार की कोणीय प्लेट का उपयोग करते हैं?</p> <p>A1 : Solid ठोस</p> <p>A2 : Slotted स्लॉटेड</p>	2.0	0.00

A3 Swivel

:

स्वीवल

A4 Box

:

बॉक्स

Trade Theory

34	34	<p>What is the most accepted method of representing roughness? खुरदरेपन को प्रदर्शित करने के लिए सबसे स्वीकृत तरीका कौनसा है?</p> <p>A1 Grade number : ग्रेड नंबर</p> <p>A2 Symbol : प्रतीक</p> <p>A3 Units : इकाइयों</p> <p>A4 Weight : वजन</p>	2.0	0.00
----	----	--	-----	------

Trade Theory

35	35	<p>What is the purpose of slots milled on two planes of angle plate? कोणीय प्लेट के दोनों सतह पर स्लॉट का क्या उद्देश्य होता है?</p> <p>A1 Reduce the weight : वजन कम करना</p> <p>A2 Clamp the job : जॉब की क्लैम्प करना</p> <p>A3 Maintain accuracy : सटीकता बनाए रखना</p> <p>A4 Good appearance : अच्छा दिखाना</p>	2.0	0.00
----	----	--	-----	------

Trade Theory

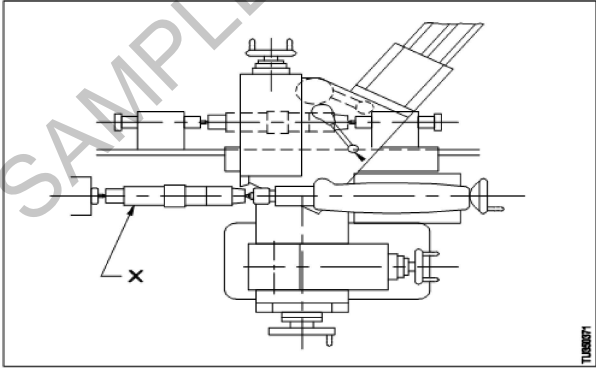
36	36	<p>Which part is marked as 'X' in copying attachment? कोपिंग अटैचमेंट में 'X' चिह्नित भाग को क्या कहते हैं?</p> 	2.0	0.00
----	----	--	-----	------

A1 Master profile

:

मास्टर प्रोफाइल

A2 Stylus

:

स्टाइलस

A3 Work piece

:

वर्क पिस

A4 Rear tool slide
:
रियर टूल स्लाइड

Trade Theory

37

37

What is the name of lathe attachment?
लेथ अटैचमेंट का नाम क्या है?

2.0

0.00

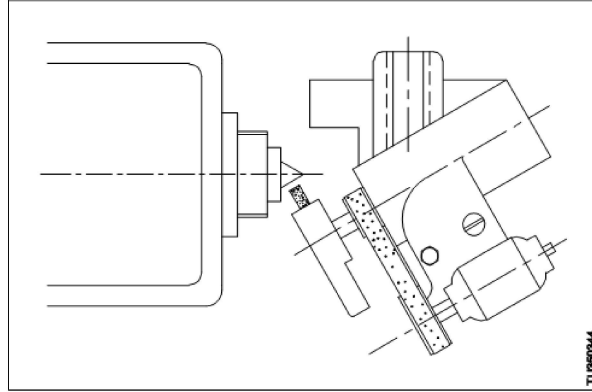

A1 Taper turning attachment

:
टेपर टर्निंग अटैचमेंट

A2 Milling attachment

:
मिलिंग अटैचमेंट

A3 Grinding attachment

:
ग्राइंडिंग अटैचमेंट

A4 Copying attachment

:
कोपिंग अटैचमेंट

Trade Theory

SAMPLE QUESTION PAPER SET 2

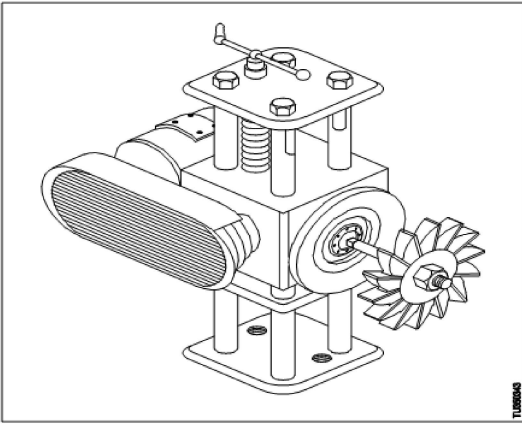
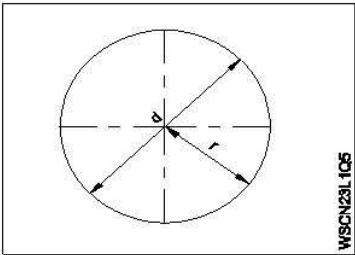
38	38	<p>What is the name of lathe attachment? लेथ अटैचमेंट का नाम क्या है?</p>  <p>A1 Taper turning attachment : टेपर टर्निंग अटैचमेंट</p> <p>A2 Milling attachment : मिलिंग अटैचमेंट</p> <p>A3 Grinding attachment : ग्राइंडिंग अटैचमेंट</p> <p>A4 Copying attachment : कोपिंग अटैचमेंट</p>	2.0	0.00
Workshop Calculation Science				
39	39	<p>Which one of the following geometrical shape's centre of gravity lies from its base is 1/3 of its height? निम्नमें से कौन सा ज्यामितीय आकृति का गुरुत्वाकर्षण केंद्र इसके आधार से स्थित है, इसकी ऊँचाई 1/3 है?</p> <p>A1 Square : वर्ग</p> <p>A2 Rhombus : विषमकोण</p> <p>A3 Triangle : त्रिभुज</p> <p>A4 Cone : शंकु</p>	2.0	0.00
Workshop Calculation Science				
40	40	<p>What is the formula for circumference of a circle? वृत्त की परिधि का सूत्र क्या है?</p>  <p>A1 : πr^2</p>	2.0	0.00

A2
:

$$\frac{\pi d^2}{4}$$

A3
:

$$2\pi r$$

A4
:

$$\pi r$$

Workshop Calculation Science

41

41

What is the formula for area of the circle?

2.0

0.00

वृत्त के क्षेत्रफल के लिए सूत्र क्या है?

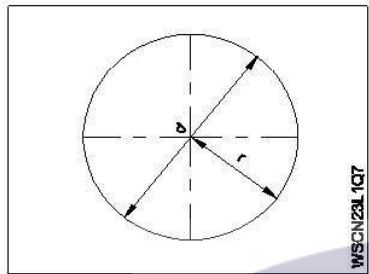

A1
:

$$\frac{\pi r^2}{2}$$

A2
:

$$\pi r^2$$

A3
:

$$2\pi r$$

A4
:

$$\frac{\pi d}{2}$$

Workshop Calculation Science

42

42

What is the radius of a circle whose diameter is 44 cm?

2.0

0.00

वृत्त की त्रिज्या क्या है जिसका व्यास 44cm है?

A1
: 44 cm

44 cm

A2
: 22 cm

22 cm

A3
: 23 cm
23 cm
A4
: 20 cm
20 cm

Workshop Calculation Science

43 43

Which type of stress?
कौन-सा प्रतिबल है?

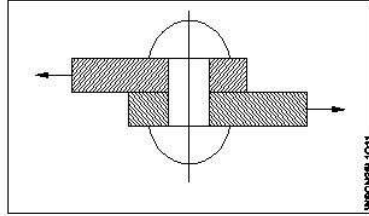

A1
: Tensile stress

तनाव प्रतिबल

A2
: Compressive stress

सम्पीडन प्रतिबल

A3
: Shear stress

कर्तन प्रतिबल

A4
: Torsional stress

टॉर्सनल प्रतिबल

Workshop Calculation Science

44 44

What is the maximum percentage of stretch of its original length is allowable for elastic materials?
लोचदार सामग्री के लिए इसकी मूल लम्बाई का अधिकतम प्रतिशत क्या स्वीकार्य है?

A1
: 100%

100%

A2
: 200%

200%

A3
: 300%

300%

A4
: 400%

400%

Engineering Drawing

45 45

The head for boiler application's shown in the figure given below is _____
नीचे दिए गए चित्र में दिखाए गए बॉयलर एप्लिकेशन के लिए हेड है.....

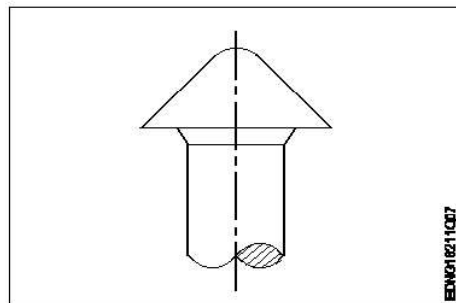

A1
: snap

स्नैप

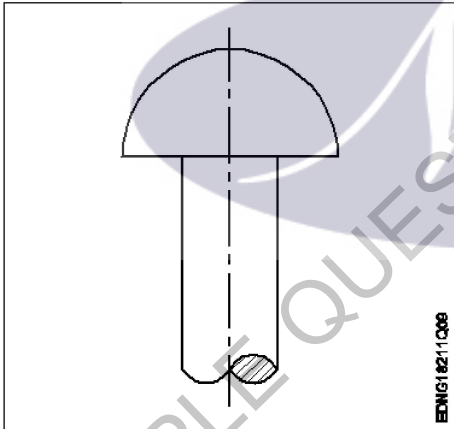
		<p>A2 pan : पैन</p> <p>A3 conical : शंकाकार</p> <p>A4 steeple : स्टीपल</p>		
Engineering Drawing				
46	46	<p>Riveted joints is a _____ रिवेटेड जॉइंट _____ है</p> <p>A1 permanent joints : स्थायी जॉइंट</p> <p>A2 temporary joints : अस्थायी जॉइंट</p> <p>A3 semi permanent : अर्ध स्थायी</p> <p>A4 none of these : इनमें से कोई नहीं</p>	2.0	0.00
Engineering Drawing				
47	47	<p>Identify the given rivet. दिए गए रिबेट को पहचानें।</p> <div style="text-align: center;">  </div> <p>A1 Snap head : स्नेप हेड</p> <p>A2 Flat head : फ्लैट हेड</p> <p>A3 Counter sunk : काउंटर सन्क</p> <p>A4 Pan head : पैन हेड</p>	2.0	0.00
Engineering Drawing				
48	48	<p>Which materials pipe is used for drainage pipe line? ड्रेनेज पाइपलाइन के लिए किस मटेरियल पाइप का उपयोग किया जाता है?</p> <p>A1 PVC pipe : PVC पाइप</p>	2.0	0.00

		<p>A2 Brass Pipe : पीतल के पाइप</p> <p>A3 G.I. Pipe : G.I. पाइप</p> <p>A4 Steel pipe : स्टील का पाइप</p>		
Engineering Drawing				
49	49	<p>Which of the following is used to block the pipe at one end? निम्न में से किसका प्रयोग पाइप को एक सिरे पर ब्लॉक करने के लिए किया जाता है?</p> <p>A1 Plug : प्लग</p> <p>A2 Union : यूनियन</p> <p>A3 Reducer : रिड्यूसर</p> <p>A4 Couplings : कपलिंग्स</p>	2.0	0.00
Engineering Drawing				
50	50	<p>Which one of the following accommodates four pipes in a pipe fitting? निम्नलिखित में से कौन-सा एक पाइप फिटिंग में चार पाइपों को समायोजित करता है?</p> <p>A1 Union : यूनियन</p> <p>A2 Cross : क्रॉस</p> <p>A3 Elbow : एलबो</p> <p>A4 Tee : टी</p>	2.0	0.00
Employability Skills				
51	51	<p>Complete the sentence with suitable describing words It is a _____ neighbourhood. One need not fear. Complete the sentence with suitable describing words It is a _____ neighbourhood. One need not fear.</p> <p>A1 good : good</p> <p>A2 big : big</p> <p>A3 safe : safe</p> <p>A4 expensive : expensive</p>	2.0	0.00
Employability Skills				
52	52	<p>Complete the sentence with suitable describing words There isn't any amusement park in the area. It is a ___ place. Complete the sentence with suitable describing words There isn't any amusement park in the area. It is a ___ place.</p> <p>A1 polluted : polluted</p>	2.0	0.00

		<p>A2 dry : dry</p> <p>A3 noisy : noisy</p> <p>A4 boring : boring</p>		
Employability Skills				
53	53	<p>Complete the sentence with suitable describing words There is a factory in the area. The air is _____.</p> <p>Complete the sentence with suitable describing words There is a factory in the area. The air is _____.</p> <p>A1 polluted : polluted</p> <p>A2 boring : boring</p> <p>A3 uneven : uneven</p> <p>A4 noisy : noisy</p>	2.0	0.00
Employability Skills				
54	54	<p>Complete the sentence with suitable describing words There is water scarcity in the locality. The area is _____.</p> <p>Complete the sentence with suitable describing words There is water scarcity in the locality. The area is _____.</p> <p>A1 uneven : uneven</p> <p>A2 noisy : noisy</p> <p>A3 dry : dry</p> <p>A4 boring : boring</p>	2.0	0.00
Employability Skills				
55	55	<p>Complete the sentence with suitable describing words The transportation to some rural areas is difficult as the roads are _____</p> <p>Complete the sentence with suitable describing words The transportation to some rural areas is difficult as the roads are _____</p> <p>A1 dry : dry</p> <p>A2 polluted : polluted</p> <p>A3 boring : boring</p> <p>A4 uneven : uneven</p>	2.0	0.00
Employability Skills				
56	56	<p>What help us to maintain the balance between mental and physical activities?</p> <p>What help us to maintain the balance between mental and physical activities?</p> <p>A1 Hobbies : Hobbies</p>	2.0	0.00

		<p>A2 Running : Running</p> <p>A3 Walking : Walking</p> <p>A4 Reading : Reading</p>		
Employability Skills				
57	57	<p>When you meet the instructor inside or outside the ITI, it is.... When you meet the instructor inside or outside the ITI, it is....</p> <p>A1 always formal : always formal</p> <p>A2 . formal inside the ITI : . formal inside the ITI</p> <p>A3 informal the ITI : informal the ITI</p> <p>A4 informal outside : informal outside</p>	2.0	0.00
Employability Skills				
58	58	<p>Role models _____ people to follow them Role models _____ people to follow them</p> <p>A1 elevate : elevate</p> <p>A2 instruct : instruct</p> <p>A3 inspire : inspire</p> <p>A4 motivate : motivate</p>	2.0	0.00
Employability Skills				
59	59	<p>Spoken communication is usually not only _____ but also _____ Spoken communication is usually not only _____ but also _____</p> <p>A1 formal, informal : formal, informal</p> <p>A2 verbal, nonverbal : verbal, nonverbal</p> <p>A3 verbal, informal : verbal, informal</p> <p>A4 formal, nonverbal : formal, nonverbal</p>	2.0	0.00
Employability Skills				
60	60	<p>The immediate surroundings to the place you live in is called _____ The immediate surroundings to the place you live in is called _____</p> <p>A1 village : village</p> <p>A2 town : town</p>	2.0	0.00

		town A3 : city city A4 : neighbourhood neighbourhood		
Employability Skills				
61	61	The conditions in a place that affect the behaviour and development of somebody or something is called _____ The conditions in a place that affect the behaviour and development of somebody or something is called _____ A1 : neighbourhood neighbourhood A2 : environment environment A3 : locality locality A4 : facilities facilities	2.0	0.00
Employability Skills				
62	62	Which kind of persons are with very good behaviour, achievements and lead as an example? Which kind of persons are with very good behaviour, achievements and lead as an example? A1 : customer service executives customer service executives A2 : ITI instructors ITI instructors A3 : role models role models A4 : sales supervisors sales supervisors	2.0	0.00
Employability Skills				
63	63	There ----- a coffee shop -----the park. There ----- a coffee shop -----the park. A1 : are, next to are, next to A2 : is, next to is, next to A3 : is, next is, next A4 : are, next are, next	2.0	0.00
Employability Skills				
64	64	Rainwater harvesting ----- to prevent water scarcity Rainwater harvesting ----- to prevent water scarcity A1 : gives gives A2 : gave gave	2.0	0.00

		<p>A3 help : help</p> <p>A4 helps : helps</p>		
Employability Skills				
65	65	<p>Identify the opposites. clean x -----, healthy x ----- Identify the opposites. clean x -----, healthy x -----</p> <p>A1 dirty, health : dirty, health</p> <p>A2 . dirty, healthy : . dirty, healthy</p> <p>A3 dirt, unhealthy : dirt, unhealthy</p> <p>A4 dirty, unhealthy : dirty, unhealthy</p>	2.0	0.00
Employability Skills				
66	66	<p>Which one is not an adventure? Which one is not an adventure?</p> <p>A1 climbing mountains : climbing mountains</p> <p>A2 trekking : trekking</p> <p>A3 surfing : surfing</p> <p>A4 driving : driving</p>	2.0	0.00
Employability Skills				
67	67	<p>Travelling in the sea is called a _____ Travelling in the sea is called a _____</p> <p>A1 voyage : voyage</p> <p>A2 boating : boating</p> <p>A3 fishing : fishing</p> <p>A4 tour : tour</p>	2.0	0.00
Employability Skills				
68	68	<p>There are many dos and don'ts to be -----while preparing for/ attending an _____ There are many dos and don'ts to be -----while preparing for/ attending an _____</p> <p>A1 there, interview : there, interview</p> <p>A2 identify, : identify,</p> <p>A3 identified, interviewed : identified, interviewed</p>	2.0	0.00

		<p>identified, interviewed</p> <p>A4 identified, interview : identified, interview</p>		
Employability Skills				
69	69	<p>Always ----- your mobile phone ----- silent mode. Always ----- your mobile phone ----- silent mode.</p> <p>A1 know, in : know, in</p> <p>A2 know, of : know, of</p> <p>A3 keep, in : keep, in</p> <p>A4 keep, of : keep, of</p>	2.0	0.00
Employability Skills				
70	70	<p>The Everest, the ----- peak in the world, ----- in Tibet. The Everest, the ----- peak in the world, ----- in Tibet.</p> <p>A1 high, is : high, is</p> <p>A2 higher, is : higher, is</p> <p>A3 highest, are : highest, are</p> <p>A4 highest, is : highest, is</p>	2.0	0.00
Employability Skills				
71	71	<p>Which language is essential to become a Computer professional? Which language is essential to become a Computer professional?</p> <p>A1 Mother tongue : Mother tongue</p> <p>A2 Chinese : Chinese</p> <p>A3 English : English</p> <p>A4 Hindi : Hindi</p>	2.0	0.00
Employability Skills				
72	72	<p>Which is the Synonym for "loyal"? Which is the Synonym for "loyal"?</p> <p>A1 Faithful : Faithful</p> <p>A2 Prosperous : Prosperous</p> <p>A3 Utopian : Utopian</p>	2.0	0.00

		A4 Perfect : Perfect		
Employability Skills				
73	73	When you speak to your supervisor, you should be _____. When you speak to your supervisor, you should be _____.	2.0	0.00
		A1 Aggressive : Aggressive A2 Formal : Formal A3 Informal : Informal A4 Casual : Casual		
Employability Skills				
74	74	Which one is the describing word from among the words given? Which one is the describing word from among the words given?	2.0	0.00
		A1 Mobile phone : Mobile phone A2 Water : Water A3 Pull : Pull A4 Magnificent : Magnificent		
Employability Skills				
75	75	A _____ sentence is a sentence that expresses a direct , command, invitations, warning or instruction. A _____ sentence is a sentence that expresses a direct , command, invitations, warning or instruction.	2.0	0.00
		A1 simple : simple A2 compound : compound A3 imperative : imperative A4 adjective : adjective		

Turner - 2nd year (Eng) SET 2

Question Number	Correct Alternative position
1	A1
2	A2
3	A3
4	A1
5	A2
6	A1
7	A4
8	A1
9	A3
10	A2
11	A3
12	A1
13	A2
14	A3
15	A1
16	A2
17	A2
18	A4
19	A3
20	A3
21	A3
22	A3
23	A1
24	A2
25	A1
26	A2
27	A3
28	A1
29	A1
30	A2
31	A2
32	A1
33	A3
34	A1
35	A2
36	A3
37	A3
38	A2
39	A3
40	A3
41	A2
42	A2
43	A3
44	A3
45	A4

46	A3
47	A1
48	A1
49	A1
50	A2
51	A3
52	A4
53	A1
54	A3
55	A4
56	A1
57	A1
58	A3
59	A2
60	A4
61	A2
62	A3
63	A2
64	A4
65	A4
66	A4
67	A1
68	A4
69	A3
70	A4
71	A3
72	A1
73	A2
74	A4
75	A3

KEY ANSWER SET 2