

**WELDER
(PRACTICAL)
SEMESTER - II**

Time: 8 Hrs.

Marks: 270

Note: Attempt all questions.

1. Write list of tools, equipment and instruments required and working steps to complete job 1 and 2. (30)
2. Weld the M.S plates by CO2 welding as per drawing given below. (140)

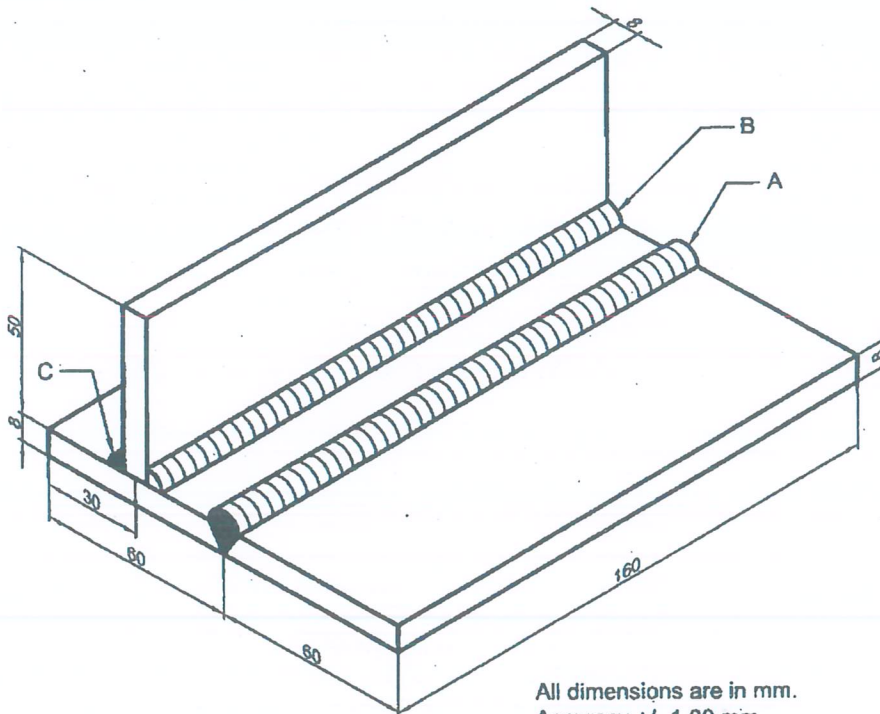

3. Weld by TIG welding Tee joint on aluminium sheets 3.15 mm thick as shown in figure given below. (100)

