

**WELDER/WELDER (GAW & GTAW)/WELDER PIPE/WELDER STRUCTURAL/WELDER
(WELDING & INSPECTION)/WELDER (FABRICATION & FITTING)
(PRACTICAL)
SEMESTER-I**

TIME: 8 HRS.

MARKS: 270

Note: Attempt all questions.

- Write list of tools, equipment and instruments required and working steps to complete the job 1 and 2 (separately) (15+15=30)
- (Job 1) Prepare the job as per figure below by electric arc welding. (150)

Weld A	Horizontal position
Weld B	Downhand position
Weld C	Overhead position

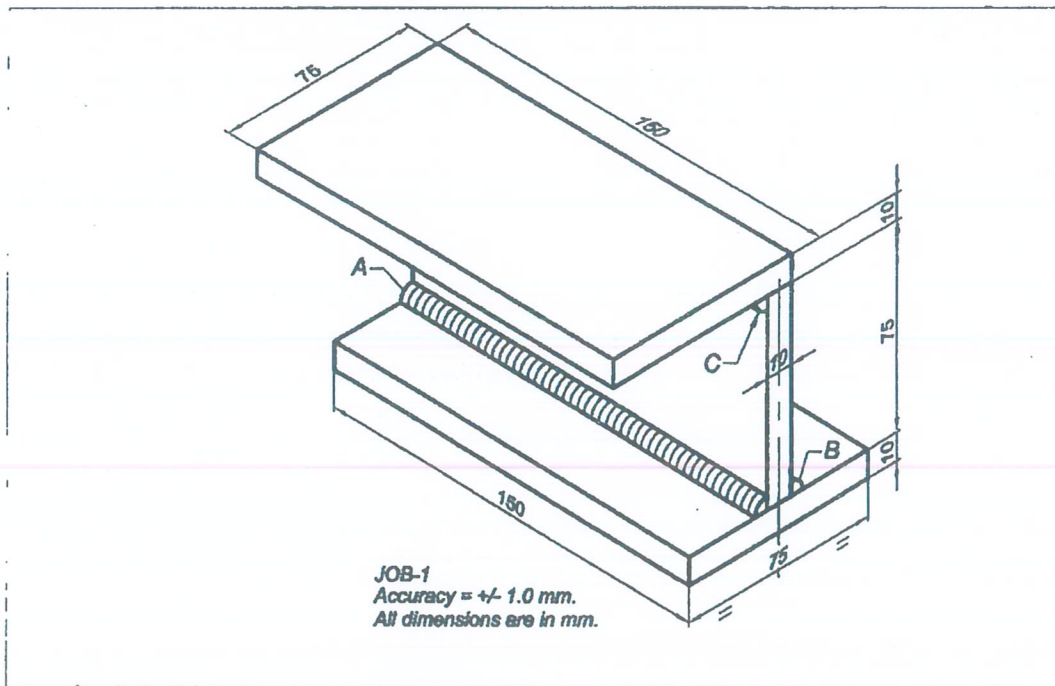

- (Job 2) Prepare the job by welding M.S. sheets as per figure given below by gas welding. (90)

