

**WELDER (GAS & ELECTRIC) / WELDER (GMAW & GTAW) WELDER PIPE / WELDER
STRUCTURAL / WELDER (WELDING & INSPECTION / WELDER (FABRICATION &
FITTING)
(PRACTICAL)
SEMESTER - I**

TIME : 8 Hrs.

MARKS: 270

Note:- Attempt all questions.

1. Prepare the single "V" Butt joint on MS plate 10mm thick in over head position by SMAW. (200)
2. Write the sequence of operations with safety precautions observed in completing the job. Also list the tools & equipments required for preparing the job (40)

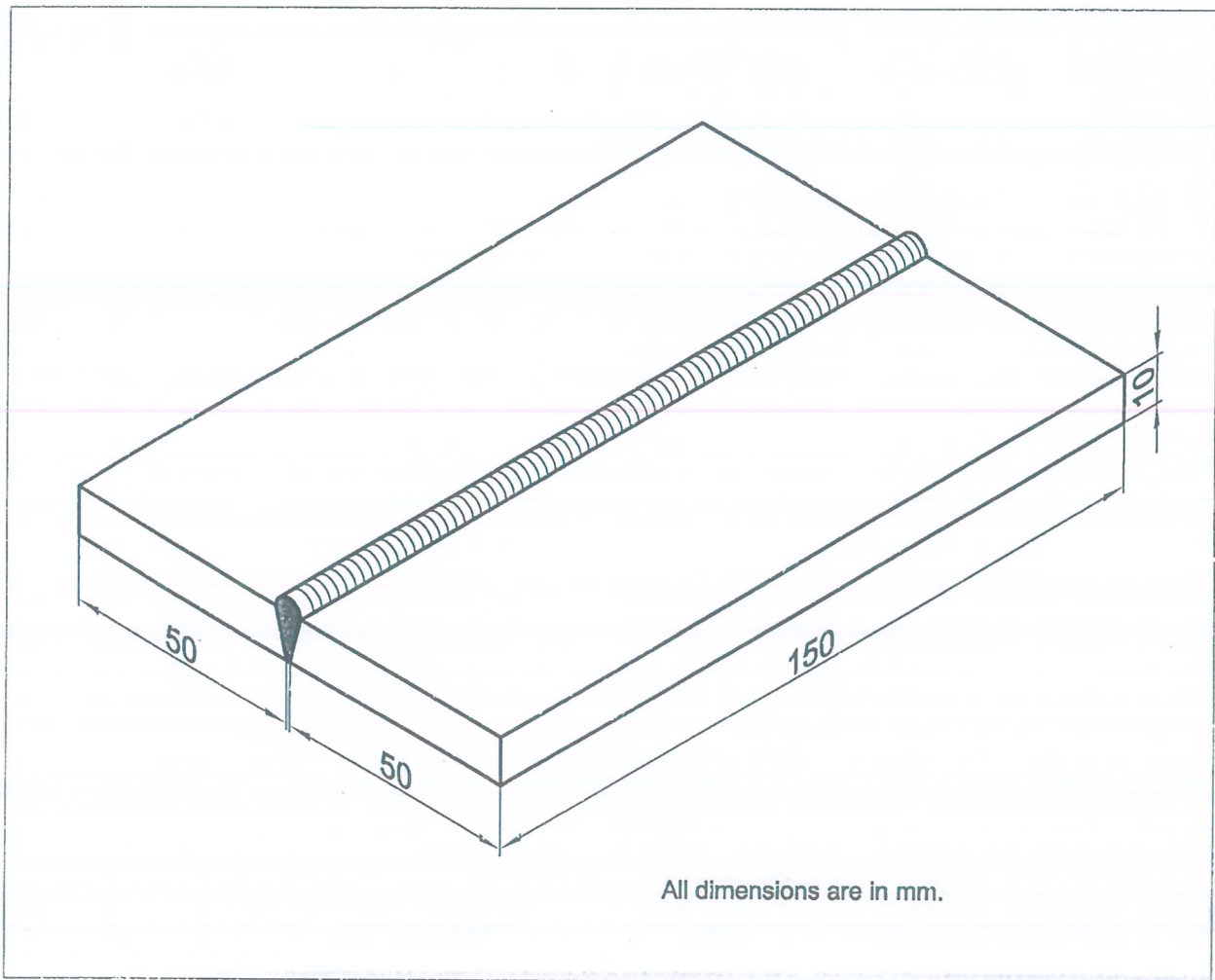

3. Viva-voce.

(30)
