

P-2
WELDER
(PRACTICAL)
SEMESTER II

Time: 8 hrs.

Marks: 270

Note: Attempt all questions.

1. Write list of tools, equipment and instruments required and working steps to complete Job 1 and Job2. (30)
2. Job 1. Weld M.S. Plates (Figure given below) by CO2 welding. (150)

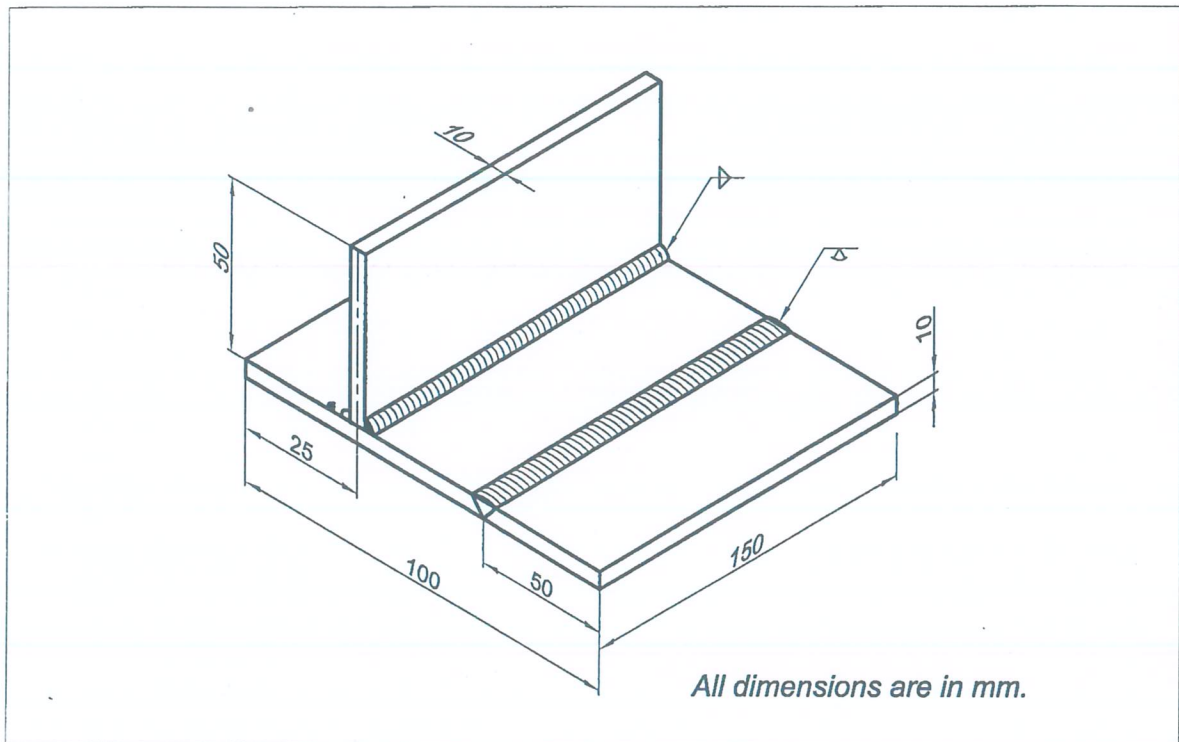

3. Job2. Weld by TIG welding aluminium sheets 2 mm thick as shown in figure given Below. (90)

